

**Digital Equipment Corporation
Maynard, Massachusetts**



DC08

Telegraph Line Subsystem Option

DC08
TELEGRAPH LINE SUBSYSTEM OPTION
ADDENDUM TO DC08 EQUIPMENT DESCRIPTION

Copyright © 1970 by Digital Equipment Corporation

The material in this manual is for information purposes and is subject to change without notice.

The following are trademarks of Digital Equipment Corporation, Maynard, Massachusetts

DEC
FLIP CHIP
DIGITAL

PDP
FOCAL
COMPUTER LAB

CONTENTS

	Page
CHAPTER 1 INTRODUCTION AND DESCRIPTION	
1.1 Scope of Addendum	1-1
1.2 Equipment Application	1-1
1.3 Equipment Description	1-1
CHAPTER 2 INSTALLATION	
2.1 DC08C/DC08CS Telegraph Line Adapter Panel	2-1
2.1.1 Module Location	2-1
2.1.2 Power Requirements	2-1
2.1.3 Environmental Conditions	2-2
2.1.4 Interface Cabling	2-2
2.2 DC08D Telegraph Line Terminator Panel	2-2
2.3 DC08EB Telegraph Line Current Adjustment and Monitor Panel	2-2
2.4 Installation Procedure (DC08C, DC08EB, and DC08D)	2-2
2.5 Installation Procedure for DC08CS	2-10
CHAPTER 3 OPERATION	
3.1 Controls and Indicators	3-1
3.2 Operating Procedures	3-1
CHAPTER 4 THEORY	
4.1 General	4-1
4.2 Operation of DC08C	4-1
4.2.1 Transmitter	4-1
4.2.2 Receiver	4-4
4.3 Operation of DC08CS	4-4
4.3.1 Transmitter	4-4
4.3.2 Receiver	4-5
CHAPTER 5 MAINTENANCE	
5.1 General	5-1
5.2 DC08CS Test Description	5-1
5.3 DC08C/DC08CS Test Procedures	5-1

CONTENTS (Cont)

		Page
5.4	DC08D Test Description	5-2
5.5	DC08EB Test Description	5-3

CHAPTER 6	DIAGRAMS	6-1
-----------	----------	-----

ILLUSTRATIONS

Figure No.	Title	Art. No.	Page
1-1	TLSO in a Typical System Configuration	08-0475	1-3
2-1	Interface Cabling Diagram	08-0477	2-3
2-2	Installation Procedure Flow Diagram	08-0474	2-4
2-3(a)	DC08C/DC08CS Test Connections for Installations with Power Supplied by the System	08-0471	2-6
2-3(b)	DC08C/DC08CS Test Connections for Installations with Power Supplied by the Line	08-0471	2-6
3-1	DC08EB Controls and Indicators	5204	3-1
4-1	TLSO Transmit/Receive Line Schematic Diagram	08-0478	4-2
4-2	TLSO Transmit/Receive Line Simplified Schematic Diagram Using the DC08M Module	08-0479	4-3
4-3	Representative Waveforms	08-0472	4-5
5-1	Test Connections	08-0473	5-2

ENGINEERING DRAWINGS

Drawing Number	Title	Page
D-BS-DC08-C-2	DC08-C (Sheet 1)	6-3
D-BS-DC08-C-2	DC08-C (Sheet 2)	6-5
D-BS-DC08-C-2	DC08-C (Sheet 3)	6-7
D-MU-DC08-C-3	Module Utilization	6-9
C-CS-G856-0-1	Telegraph Level Converter	6-11
C-CS-G860-0-1	Telegraph Level Converter	6-12
D-CS-DC08-CT-1	DC08-C Tester	6-13
D-BS-DC08-CS-2	Lines 0-15	6-15
D-BS-DC08-CS-3	Lines 16-31	6-17
D-MU-DC08-CS-5	Module Utilization	6-19
C-CS-G861-0-1	Solid State Transmitter	6-21

ENGINEERING DRAWINGS (Cont)

Drawing Number	Title	Page
C-CS-G862-0-1	Solid State Receiver G862	6-22
D-CS-DC08-EB-1	Telegraph Adjustment Panel	6-23
D-UA-DC08-D-0	Panel Assembly Line Terminator	6-25
C-CS-3009282-0-0	H-716 Power Supply	6-27
C-CS-793-0-1	793 Power Supply	6-28
C-CS-793-A-1	793A 50 Cycle Power Supply	6-29

TABLES

Table Number	Title	Page
1-1	Module Specifications	1-2
2-1	DC08CS Power Data	2-1
2-2	DC08C Power Data	2-1
2-3	G861 Option Jumpers	2-10
2-4	G862 Option Jumpers	2-11
3-1	DC08EB Controls and Indicators	3-2

1.1 SCOPE OF ADDENDUM

This addendum describes the DC08 Telegraph Line Subsystem Option (TLSO) equipment. Refer to the DC08 Data Communications Equipment Manual (DEC-8I-H80A-D) for basic system application and operation.

1.2 EQUIPMENT APPLICATION

The DC08 TLSO is used with the DC08A Data Communication equipment as follows:

- a. To convert the computer output signals to telegraph levels
- b. To convert telegraph line levels to computer logic levels
- c. To provide the necessary power to drive telegraph lines
- d. To terminate the telegraph line
- e. To provide a means of monitoring and adjusting both transmit and receive line currents for up to 32 neutral or bipolar lines.

1.3 EQUIPMENT DESCRIPTION

The TLSO is shown in a typical system configuration in Figure 1-1. In the complete configuration, the TLSO comprises the DC08C (or DC08CS) Telegraph Line Adapter Panel with Type 793 Power Supply and Type 893 Fuse Panel; the DC08EB Line Current Adjusting Option; and the DC08D Line Terminator Panel.

The TLSO operates as part of the 680/I System and provides up to 32 line interfaces between 32 telegraph lines and the DC08A Serial Line Multiplexer. There are 16 M750 Modules within the DC08A; each of which implements two full-duplex lines to accommodate up to 32 telegraph line interfaces via the TLSO. Because of line battery power considerations, the system is divided into two configurations:

- a. One configuration provides the necessary power supply and line adjusting equipment when line power is not being supplied.
- b. The other configuration assumes the necessary power from the telegraph lines and provides only the primary equipment.

The DC08C unit contains either a G856 or G860 Line Adapter Module. Each module contains transmitter and receiver circuits that consist of transistors and mercury-type relay switches. The choice of either a G856 or G860 Module depends entirely on the location where the DC08C is to be used. The G856 Module is usually used for installations in the United Kingdom and Australia. The primary difference between the two modules is that the G860 Module is capable of switching a higher voltage than the G856. The specifications for each module are listed in Table 1-1.

Table 1-1
Module Specifications

Specifications	DC08C		DC08CS	
	G856	G860	G861	G862
Logic Power Requirements	-15V, 54 mA	+5V, 57 mA	+5V, 75 mA	+5V, 75 mA
Maximum Data Rates	200 Baud	200 Baud	40,000 Baud	40,000 Baud
Telegraph Line Power Requirements	5 mA to 100 mA	5 mA to 100 mA	5 mA to 100 mA	N/A
Voltage Switching Capability	90V, Max.	90V to 135V	200V, Max.	200V, Max.

A solid-state version of the DC08C has been added to the product line. This new version, designated DC08CS, contains one DC08CM Module Set, which comprises the G861 Transmitter and the G862 Receiver. The function, signals, and connections for the DC08CS are identical to the DC08C. The specifications for the G861 and G862 are listed in Table 1-1.

The DC08CS contains 16 Dual Line Adapter Modules, which can interface up to 32 telegraph lines. Each DC08CS can contain 16 DC08CM Module Sets, each of which in turn, comprises one G861 and one G862 Dual Line Adapter that service two telegraph lines. Thus, the overall interface capability of the DC08CS is 32 telegraph lines.

The DC08EB Line Current Adjusting Option provides rheostats (on the send and receive lines) for adjusting line current. Meters are provided so that current on both receive and transmit lines can be measured simultaneously in both positive and negative current in bipolar or neutral operation. This option is used when the system is supplying line battery; however, there are applications in parts of the world where the DC08EB is required with or without the power option. The user should consult the price list and other sales literature pertaining to his locality.

The DC08D Line Terminator Panel provides demarcation points for interfacing the 680/I System to telegraph lines. The DC08D interfaces to the DC08EB or the DC08C and can accommodate up to 32 telegraph lines.

The 793 Power Supply is used for driving customer supplied telegraph lines (transmit only). Output is up to ± 80 Vdc with a current capacity of 2.5A. The Type 893 Fuse Panel provides fusing for both + and - transmit current sources. These fuses are rated for 250 mA maximum current.

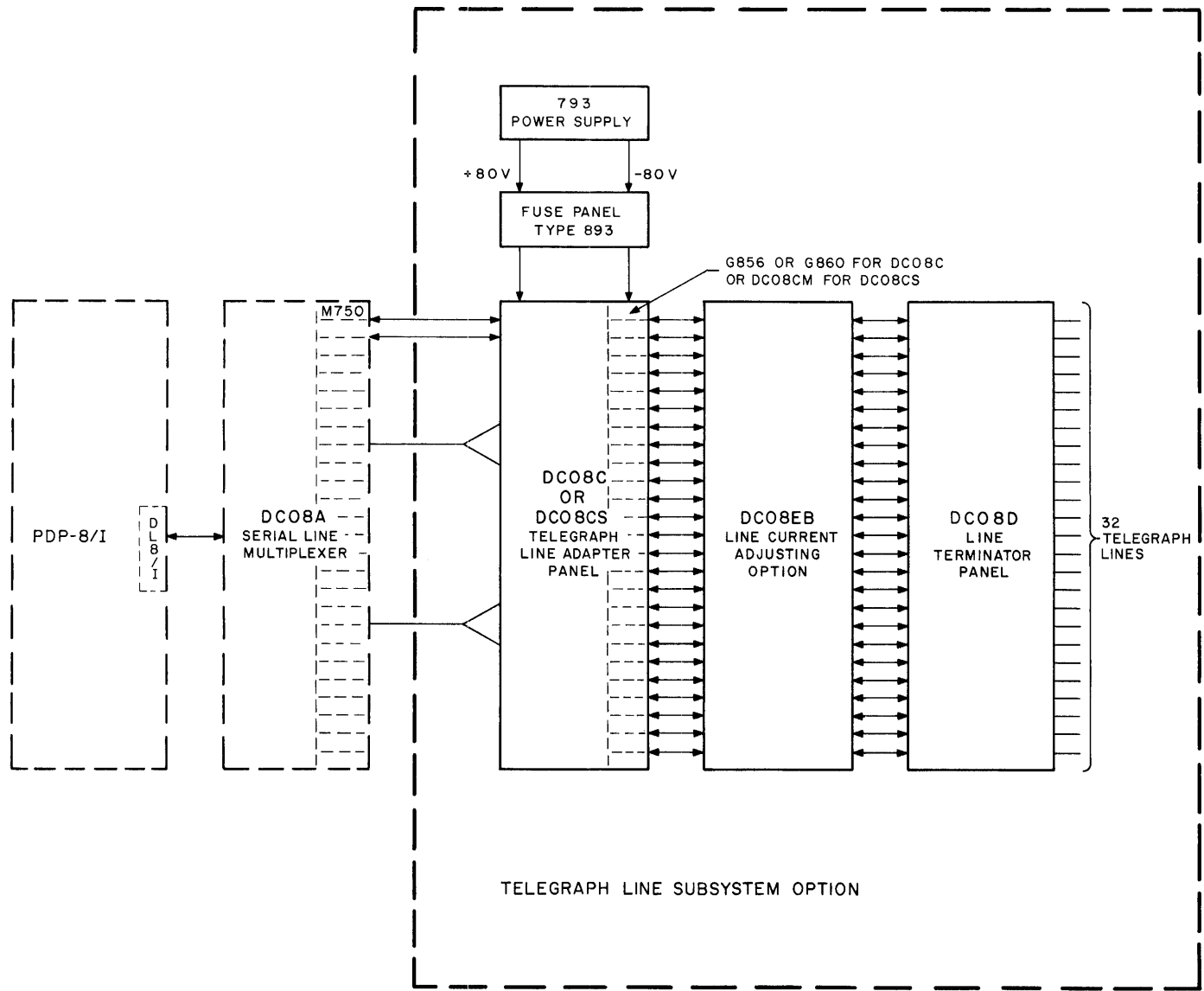

Figure 1-1 TSLSO in a Typical System Configuration

2.1 DC08C/DC08CS TELEGRAPH LINE ADAPTER PANEL

The DC08C/DC08CS is contained in one modified Type 1943 Mounting Panel that can accommodate a maximum of 16 telegraph level-converter modules and one H716 Power Supply. The H716, which provides +5V and -15V, is mounted on the right side of the panel for the DC08C and on the back door for the DC08CS.

Voltages as high as +135 Vdc, accompanied by current that could be fatal, are present on the pins; therefore, the panel is recessed in the cabinet, and a protective cover is provided as a safety precaution.

2.1.1 Module Location

Module Utilization Drawing D-MU-DC08-C-3 (refer to Chapter 6) defines the location of all DC08C/DC08CS Modules. The unit contains 16 double-width telegraph level-converter modules, which are located in panel slots A8 through A22 (two slots per module) and B8 through B22.

2.1.2 Power Requirements

The DC08CS power data is listed in Table 2-1 and the DC08C power data is listed in Table 2-2.

Table 2-1
DC08CS Power Data

Supply	Volts	Amps	Power Dissipation	Heat Dissipation
793/793A	±45V to ±80V neutral or polar	2.5A to 4.4A	500W	1767 Btu/min
H716	+5V	60 mA Rcv and Trans (per line)	45W	154 Btu/min

Table 2-2
DC08C Power Data

Supply	Volts	Amps	Power Dissipation	Heat Dissipation
793/793A	±45V to ±80V neutral or polar	2.5A to 4.4A	500W	1767 Btu/min
H716	+5V and -15V	57 mA (per line)	45W	154 Btu/min

2.1.3 Environmental Conditions

The following environmental specifications apply to the DC08C/DC08CS:

Operating Temperature: 0°C to 55°C

Noise Margin (dc): 1 Vdc

2.1.4 Interface Cabling

The interface cables and connector locations are shown in Figure 2-1.

2.2 DC08D TELEGRAPH LINE TERMINATOR PANEL

The DC08D is designed to be mounted on the left side of the communications equipment cabinet. When the cabinet is not the last cabinet in the system, the DC08D must be mounted on the rear of the cabinet to provide access to the terminal blocks.

The DC08D consists of a single-height panel with 8 terminal blocks; each terminal block has 16 terminals. The panel accommodates up to 32 half-or full-duplex telegraph lines. The terminals are numbered 1 through 16 on each of the eight terminal blocks and the terminal blocks are identified as TB1 through TB8.

All interface cables and connector locations are shown in Figure 2-1.

2.3 DC08EB TELEGRAPH LINE CURRENT ADJUSTMENT AND MONITOR PANEL

All components of the DC08EB are mounted on an 1/8-in. x 19-in. x 20-15/16-in. panel. The maximum input/output current is 100 mA. No power is required because the device is passive.

2.4 INSTALLATION PROCEDURE (DC08C, DC08EB, and DC08D)

Installation of the TLSO includes equipment emplacement, cabling, testing, and line balancing. Because of the variations in the configuration, there are four primary considerations prior to performing the installation procedure:

- a. Procedures using the tester and procedures without the tester
- b. Procedures with the power option and procedures without the power option
- c. Procedures for bipolar operation and procedures for neutral operation
- d. Procedures for the DC08C and procedures for the DC08CS.

An installation flow chart (see Figure 2-2) is provided to clarify these considerations and to ensure trouble-free installation. Use Figure 2-3 to determine the installation sequence. Each block is keyed to a procedural step. Each diamond shaped block provides direction involving the four main considerations noted above, the rectangular block identifies the procedure to follow.

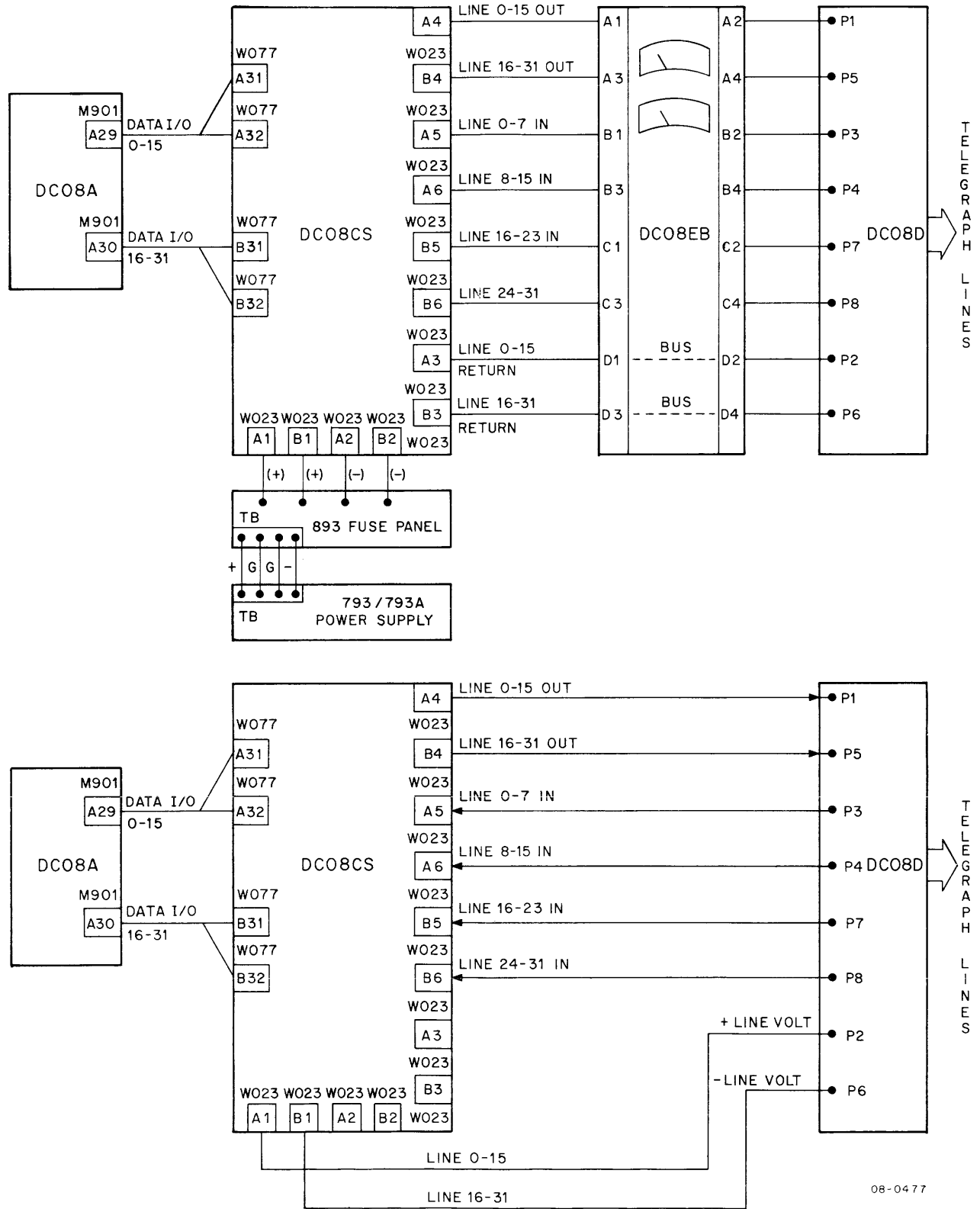
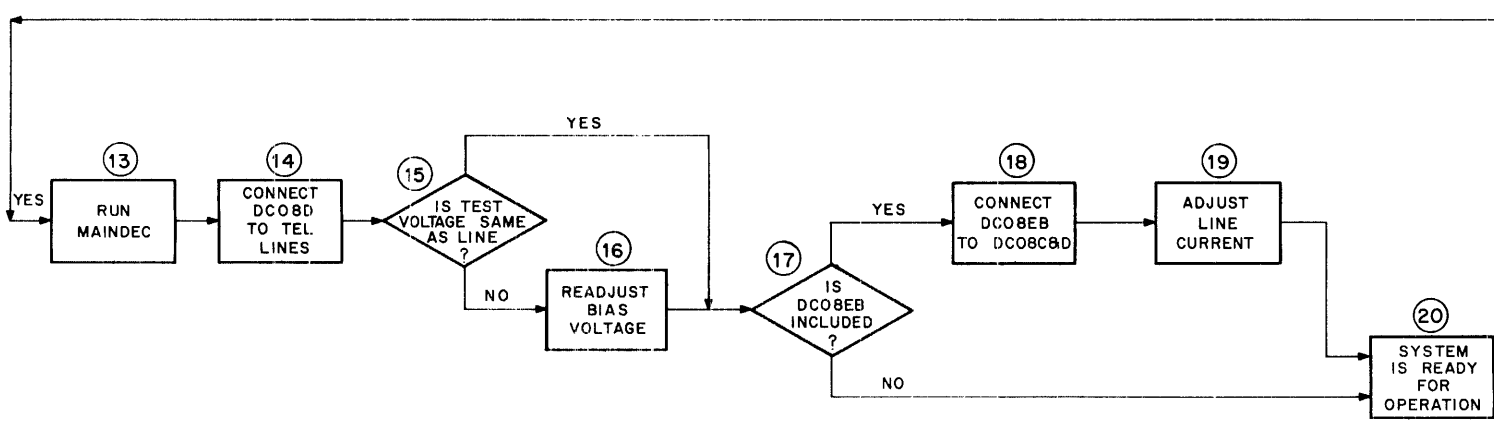
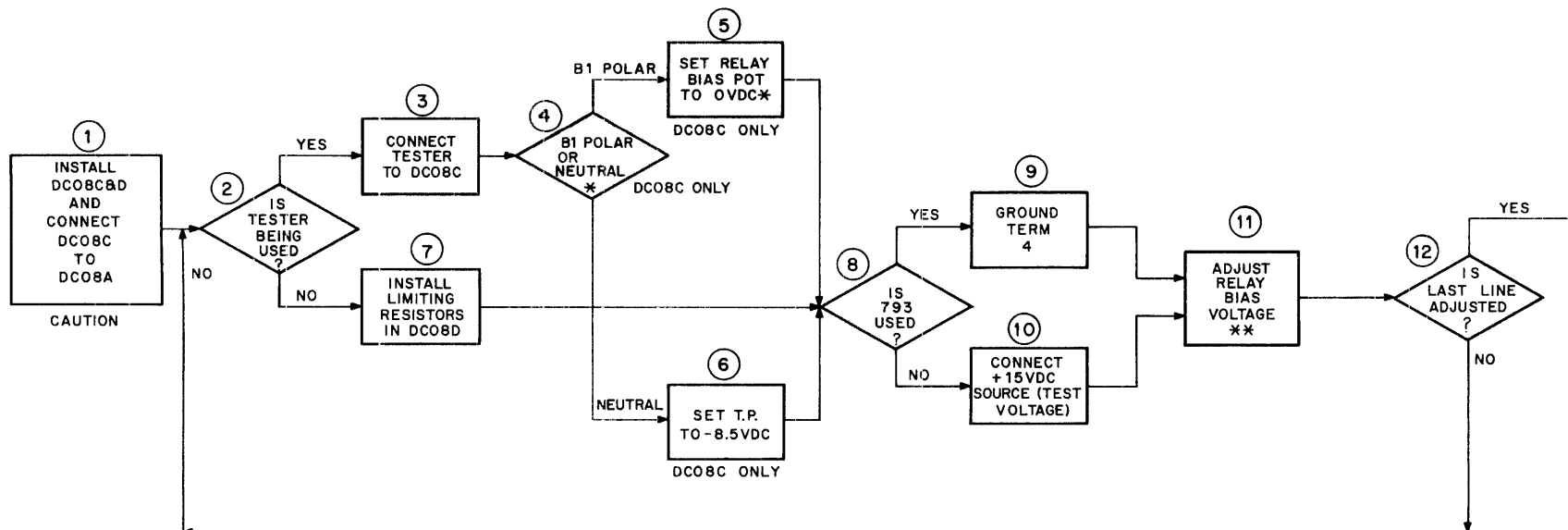

Figure 2-1 Interface Cabling Diagram



* DOES NOT APPLY WHEN USING DC08CS
 ** PROCEDURE CHANGES WHEN USING DC08CS

08-0474

Figure 2-2 Installation Procedure Flow Diagram

2-4

<u>Step</u>	<u>Procedure</u>
1	Install DC08C and DC08D. (Refer to Paragraphs 2.1 through 2.3.)
2	Is tester being used? If the tester is provided, perform procedures in Steps 3, 4, and 5 or 6 (depending on whether the system is bipolar or neutral). If the tester is not provided, perform procedures in Step 7.
3	Connect tester to DC08C. (See Figure 2-3 and instructions provided with tester.)

CAUTION

Do not make connections when power is on.

4	Bipolar or neutral? If the system is bipolar operation, perform Step 5. If the system is neutral operation, perform Step 6.
5	Set relay bias potentiometer to 0 Vdc. Using the oscilloscope, monitor the split lug (test point) located at the rear of the G856 or G860 Module under test. The lower lug (test point) is used with the odd numbered line; the upper lug (test point) is used with the even numbered line. Adjust the bias by turning the adjusting screw of the potentiometer located next to the test point. Adjust for 0 Vdc at test point.
6	Set relay bias potentiometer for an indication of -8.5 Vdc on the oscilloscope (neutral operation only). If the tester is used, adjust the potentiometer identified in Step 5 until -8.5 Vdc is read.
7	Install limiting resistor in DC08D between Terminals 1 and 3 of lines under test (see Chapter 6 for block schematic).

CAUTION

The power must be turned off before starting this step.

If a tester is not going to be used to check the DC08C transmit-receive circuits, the G856/G860 output must be jumpered to the input with a current limiting resistor. The value of the resistor should limit the current to less than 100 mA; because of the different values of current sources, the following formula is used to calculate the value of the resistor.

$$R = \frac{\text{transmit voltage (battery)}}{.050A}$$

$$\text{Power} = (.050A) (\text{transmit voltage})$$

8	Is 793 Power Supply being used? If it is not provided, perform Steps 10 and 11 or 10 and 12. If it is provided, perform Step 9 below.
9	Ground Terminal 4 of lines under test. On DC08D, connect wire from Terminal 4 to a convenient location on chassis frame.
10	Connect 15 Vdc source (no 793 Power Supply provided). Connect a -15 Vdc source to Terminal 2 of lines under test in DC08D (see block schematic in Chapter 6).
11	Is tester used? If the tester is used, perform Step 13. If the tester is not used, perform Step 12.

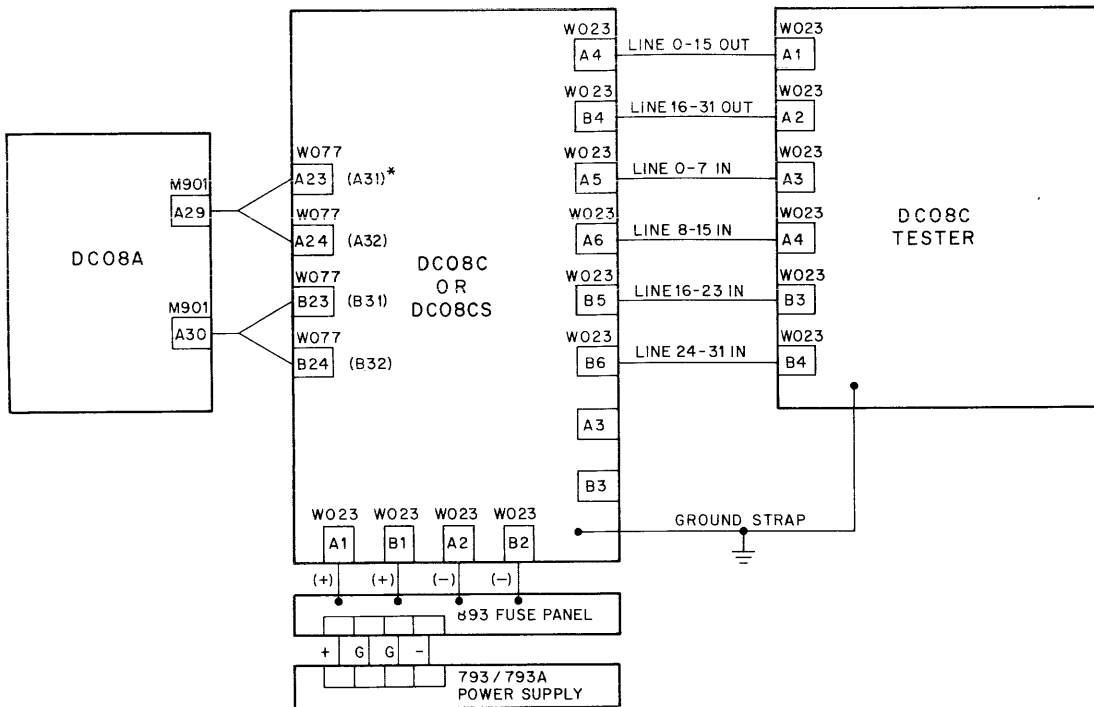
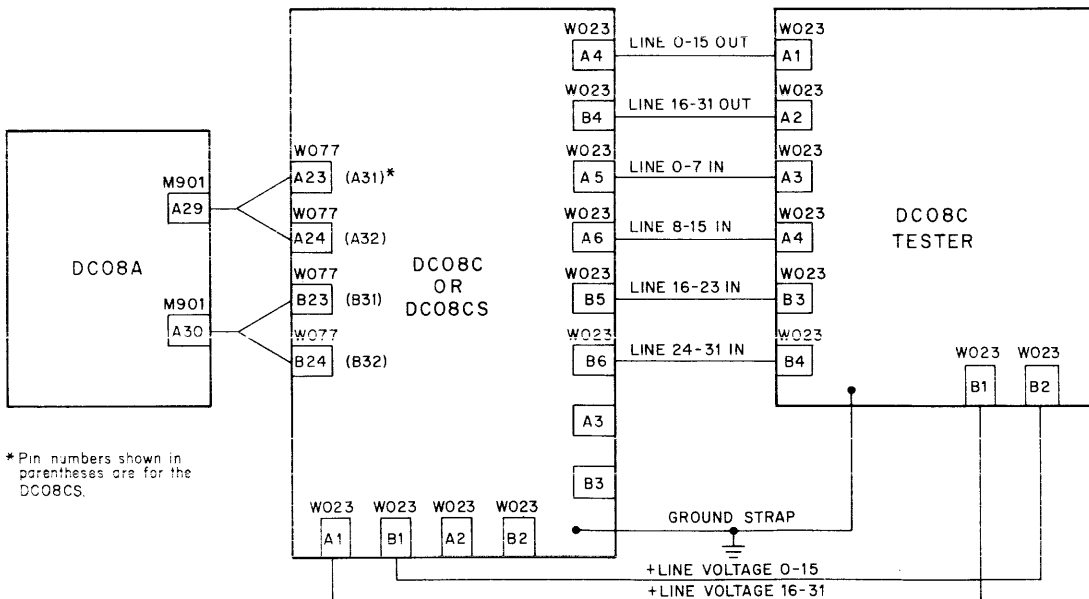

Figure 2-3(a) DC08C/DC08CS Test Connections for Installations with Power Supplied by the System



* Pin numbers shown in parentheses are for the DC08CS.

08-0471

Figure 2-3(b) DC08C/DC08CS Test Connections for Installations with Power Supplied by the Line

StepProcedure

- 12 DC08C or DC08CS. No additional adjusting for the DC08C is required now; however, if the DC08CS is used, the bias voltage must be adjusted. The procedures involve a modified version of Step 13 (refer to Paragraph 2.5).
- 13 Adjust relay bias voltage. The computer must be programmed to transmit 1s and 0s. At wire-wrap pins given below, using an oscilloscope, check and adjust relay bias voltage such that the pulse width of the receive voltage is essentially the same as the transmit voltage.

a. Monitor pins D or J of G856 or G860 for 1s and 0s from DC08A. Toggle in the program given below and observe square waves representing 1s and 0s at monitored pins.

The following program may be toggled into the computer to transmit a pattern of 1s and 0s on a line selected by the switch register. The program must be restarted to test a different line. The program is written to use Clock 1 of the DC08A.

BEG	200/	7604	OSR	
	201/	6414	TTL	
START	202/	7200	CLA	
	203/	1234	TAD K1	
	204/	3233	DCA LN	
	205/	1235	TAD K2	
	206/	3232	DCA LRN	
CLKON1	207/	6424	T1 ON	
	210/	6421	T1 SKP	
	211/	5210	JMP .-1	
	212/	4216	JMS STORE	
DONE1	213/	2233	ISZ LN	
	214/	5207	JMP CLKON	
	215/	5202	JMP START	
STORE	216/	0	STORE	
CLKOFF	217/	6422	T1 OFF	
	220/	2230	ISZ KON	
	221/	5607	JMP I CLKON	
	222/	1232	TAD LRN	
	223/	6404	TTO	
	224/	3232	DCA LRN	
	225/	1231	TAD KON2	
	226/	3230	DCA KON	
	227/	2637	JMP I DONE1	
	230/	7773	KON	/Storage
	231/	7773	KON2	/
	232/	3252	LRN	/Storage
	233/	7765	LN	/Storage
	234/	7765	K1	/
	235/	3252	K2	/Transmit Pattern
	236/	207	CLKON	/Return Address
	237/	213	DONE1	/Return Address

b. Add second scope probe to pins H or M of G856 or G860, and compare square waves of the two channels. The signals should be the same except for the time displacement of the relays being energized (in the G856 or G860).

Step

Procedure

To find the correct bias setting, compare the transmitter input with the receiver output, and adjust the bias potentiometer identified in Step 5 such that the signals are the same except for any time displacement.

NOTE

If the voltage source on the transmit relay is positive, the bias will be a negative voltage. If the voltage source is negative on the transmit relay, the bias will be a positive voltage (on split lug test point).

- 14 Is last line adjusted? If the last line has not been adjusted, repeat Steps 2 through 13 until the last line has been adjusted.
- 15 After all lines have been statically adjusted, run the DC08 off-line test MAINDEC-8I-D8AB. Refer to MAINDEC-8I-D8AB operating procedures.

NOTE

Ensure the diagnostic revision is B, or later, so that the delay of the relays may be taken into account for data comparison.

If failures occur, it may be necessary to "fine tune" using the scope loop of the program. Monitor the same test points identified in Step 13. Compare both channels and adjust pulse width of receive channel until the two signals appear alike.

- 16 Remove tester or limiting resistors and voltage source. Connect DC08D to telegraph lines.

CAUTION

Turn power off prior to performing this step.

There are four terminals provided for each line in DC08D. The following identifies each terminal so that lines may be connected accordingly:

- a. Terminal 1 carries the switched signal transmitted from the DC08 System.
- b. Terminal 2 will be ground if the customer supplies battery through the 893 Fuse Panel. Customer- or common-carrier-supplied battery may also be connected to Terminal 2 if battery is not supplied through the 893 Fuse Panel.
- c. The receive signals are connected to terminals 3 and 4; the positive signal is connected to Terminal 3. If only one wire is brought in, connect it to the appropriate terminal, and connect the other terminal to the common return.

The customer or common-carrier may supply three or four wires per telegraph line to the DC08D. The following lines may be supplied:

- a. In a three-wire configuration:
 - (1) A dc keyed signal line (transmit)
 - (2) A neutral line
 - (3) A receive line with the receive return line common to the transmit neutral line.

Step

Procedure

- b. In a four-wire configuration:
- (1) A dc keyed signal wire (transmit)
 - (2) A common-carrier battery input or a neutral connection
 - (3) A receive line
 - (4) The return for the receive line.

NOTE

In the DC08 TLSO, the line current is always provided by the sender.

- 17 Is test battery voltage same as line battery voltage? If the answer is yes, check line signals in Step 18. If the answer is no, readjust bias voltage as outlined in Step 18.
- 18 If the tester was used or a different source voltage has been connected, a complete readjustment of the bias voltage may be required after connection of the telegraph lines. If it is possible to loop data from the DC08C to the remote terminal and back (using MAINDEC-8I-D8AB or the program in Step 13), check each line for the receiver output signal. Readjust the bias network for the best operating conditions, taking into account any line distortion. If it is not possible to loop the telegraph line, the remote terminal must be made to transmit to the receiver so that the receiver bias may be adjusted for actual running conditions. Compare the signals coming into the receive relay with the signal at pin H or M (line dependent) of the G856 or G860, and adjust the bias until the signal at H or M has the same duty cycle as the input except for any time delay of relay pull-in.
- 19 Is DC08EB included? If it is, proceed to Step 20. If it is not, proceed to Step 22.
- 20 Connect DC08EB to DC08C and DC08D, as shown in Figure 2-1.

CAUTION

Turn off power prior to disconnecting and connecting cables.

- 21 Adjust line current. Set up the DC08EB as follows:
- a. Set all potentiometers to their maximum resistance (counterclockwise) for minimum current (including lines not in use).
 - b. Select each line that is to be used in the system; and adjust the corresponding transmit potentiometer (see Figure 3-1) for that line by monitoring the transmit meter (see Figure 3-1) to the current specified by the customer.
 - c. With the remote terminal transmitting to the system, adjust the receive potentiometer (see Figure 3-1) for each line by monitoring the meter to the current specified by the customer.
- 22 The system is ready for operation. If any problems occur when system operation begins, recheck previous steps; then consult Chapter 5.

2.5 INSTALLATION PROCEDURE FOR DC08CS

The G861 Transmit Module and the G862 Receive Module each contain jumper wires that determine the polarity of the output or input signal from the telegraph line (see Figure 4-2).

When the G861 Transmit Module is shipped from the factory, the jumper wires are such that a MARK from the computer results in a positive current output on the telegraph line. Table 2-3 lists the output signals on pin AR2 or BR2 for the jumper wire configurations in both neutral and bipolar operation. In some instances, it may be necessary to change the jumper wires, if the system is connected to lines that do not follow the standard arrangement. Consult Table 2-3 for the correct G861 Module jumper configuration for a particular installation. In the standard configuration (as shipped from the factory), the jumper wires on the G861 Module are physically parallel; if it is necessary to change the polarity of a MARK signal, the jumper wires form an X. The parallel and X configurations of the jumper wires are noted in Table 2-3.

Table 2-3
G861 Option Jumpers

Input	Output to Line			
	Jumpers Parallel D2 to R10, R12 Q2 to R6, R8	Jumpers Crossed D2 to R6, R8 Q2 to R10, R12	Jumpers Parallel D1 to R9, R11 Q1 to R5, R7	Jumpers Crossed D1 to R5, R7 Q1 to R9, R11
Neutral Operation	AR2 = +Current AR2 = 0 Current	AR2 = 0 Current AR2 = +Current	BR2 = +Current BR2 = 0 Current	BR2 = 0 Current BR2 = +Current
Pin AL2 0V (MARK) +3V (SPACE) Pin BL2 0V (MARK) +3V (SPACE)				
Bipolar Operation	AR2 = +Current AR2 = -Current	AR2 = -Current AR2 = +Current	BR2 = +Current BR2 = -Current	BR2 = -Current BR2 = +Current
Pin AL2 0V (MARK) +3V (SPACE) Pin BL2 0V (MARK) +3V (SPACE)				

When the G862 Receive Module is shipped from the factory, the jumper wire is such that a MARK on the telegraph line in either neutral or bipolar operation results in a 0V MARK signal to the computer. The output signals to the computer on pin S or F for jumper wire configurations in neutral and bipolar operation are listed in

Table 2-4. In some instances it may be necessary to change the jumper wires, if the system is connected to lines that do not follow the standard arrangement. Consult Table 2-4 for the correct jumper configuration for the G862 Module for a particular installation. To change polarity for the G862 Module, simply change the jumper wire from its standard location (as shipped) to the hole located next to the hole used. In the standard configuration, the jumper wire connects the upper set of holes when the module handle is to the left and the components of the module are facing up.

Table 2-4
G862 Option Jumpers

Line Input	Output to Computer			
	Jumper E4-8 to S	Jumper E4-6 to S	Jumper E1-8 to F	Jumper E1-6 to F
Neutral Operation				
Pins N,M + Current 0 Current	S = 0V S = +3V	S = +3V S = 0V		
Pins D,E + Current 0 Current			F = 0V F = +3V	F = +3V F = 0V
Bipolar Operation				
Pins N,M + Current - Current	S = 0V S = +3V	S = +3V S = 0V		
Pins D,E + Current - Current			F = 0V F = +3V	F = +3V F = 0V

Step	Procedure
1	In Paragraph 2.4, perform Steps 1 through 3.
2	Omit Steps 4, 5, and 6.
3	In place of these steps, perform the following procedure: <ol style="list-style-type: none"> a. Adjust all potentiometers on the G862 for mid-range. b. In Paragraph 2.4, perform Steps 8 through 11.
4	In Paragraph 2.4, perform Step 12; toggle in program and proceed to compare signals (Step 13). Compare the signals at the input G862 Receive Modules pins L or S with the output of the receiver pins F or J (located on the wire-wrap side of the logic plate).
5	Adjust potentiometer for best waveform. The waveform of the output from the DC08A should be the same as the input to the receiver, except for voltage magnitude.
6	In Paragraph 2.4, perform Steps 14 through 22.

Operation of the DC08C/DC08CS and DC08D are under program control; therefore, no operating controls are provided and no operating procedures are required. The DC08EB contains 2 meters, 4 rotary switches, and 64 potentiometers, which are described in this chapter.

3.1 CONTROLS AND INDICATORS

Figure 3-1 illustrates the DC08EB front panel. Table 3-1, which is keyed to Figure 3-1, describes the panel controls and indicators.

3.2 OPERATING PROCEDURES

Currents on both receive and transmit lines can be measured simultaneously. The computer operator simply turns the applicable rotary switch to the desired line; monitors the current on the meter; and adjusts the current to the desired level using the potentiometer.

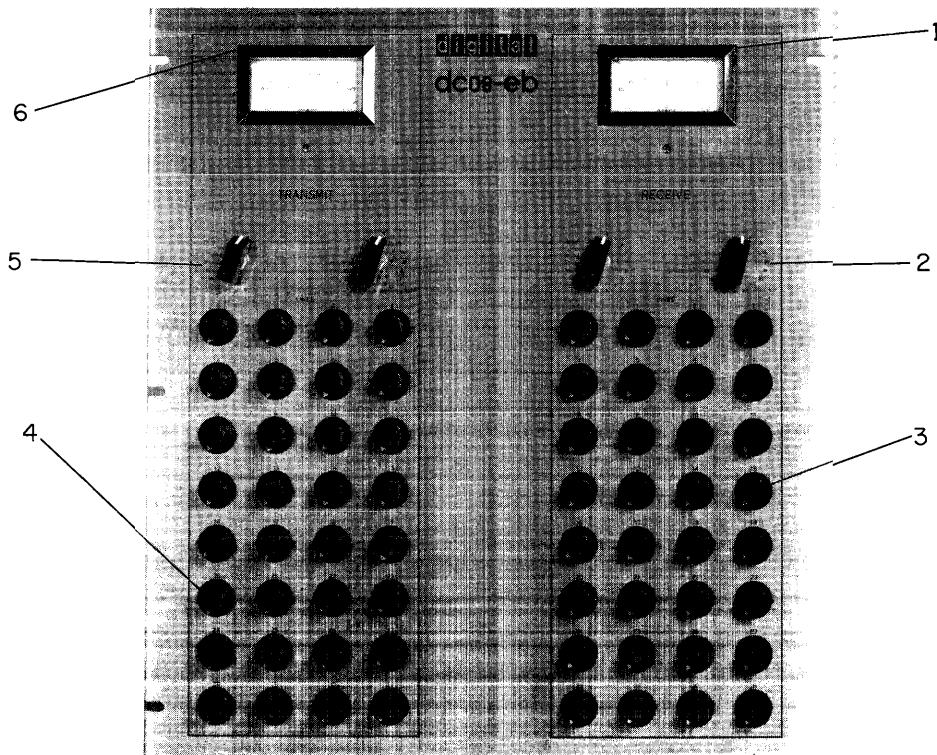

Figure 3-1 DC08EB Controls and Indicators

Table 3-1
DC08EB Controls and Indicators

Figure 3-1 Ref. No.	Control or Indicator (Qty)	Function
1	RECEIVE meter	Measures current on receive line between -100 mA and +100 mA.
2	Receive rotary selector switch (2)	A 2-pole, 17-position rotary switch. Selection of a number switches the meter across the fixed resistor for that line to measure the current of the line.
3	Receive potentiometers 0 through 31 (32)	Adjust current of designated receive line.
4	Transmit potentiometers 0 through 31 (32)	Adjust current of designated transmit line.
5	Transmit rotary selector switch	Same as receive rotary selector switch.
6	TRANSMIT meter	Measures current of transmit line between -100 mA and +100 mA.

4.1 GENERAL

This chapter treats each of the three assemblies as a subsystem for two basic reasons:

- a. The simplicity of the individual assembly (the DC08D has no electronics whatsoever and the DC08EB has only four components for any given transmission line)
- b. The DC08D is never used without the DC08C/DC08CS, and the DC08EB, an option to this subsystem, is never used without the DC08C/DC08CS and DC08D Assemblies.

4.2 OPERATION OF DC08C

4.2.1 Transmitter

Figure 4-1 is a detailed schematic diagram of one typical transmit and receive line. In its quiescent state, transistor Q1 is biased in the off condition. Under these circumstances, the collector of Q1 is high (with respect to the base), and current flows through the diode and resistor R5 to turn transistor Q2 on, energizing the coil such that the contacts close the circuit from the negative power supply to the telegraph transmit leads on the terminator panel.

With the arrival of a pulse from the computer, via the DC08A, the negative-going leading edge of the pulse turns transistor Q1 on and applies current through the coil in the opposite direction. Under these conditions, transistor Q2 is turned off by the changing voltage on the output of Q1, and the contacts associated with the relay coil are changed such that the circuit is completed between the positive power supply and the telegraph transmit lines on the terminator panel. Both sets of contacts associated with the relay coil have RC filter networks for reduction of contact arcing. The resultant output bit stream to the telegraph transmit leads is a faithful reproduction of the input signal duration with the polarity reversed and the voltage levels converted for compatibility to telegraph requirements.

When the DC08EB is not used in the subsystem, the output current is supplied directly to the DC08D Terminator Panel and output on the telegraph lines. With the DC08EB in the subsystem, the output current is applied through a 100-ohm resistor and a 5000-ohm potentiometer. A meter parallel with the 100-ohm resistor measures the current that is sent from the power supply to the telegraph lines. The potentiometer allows this current to be varied to achieve precise line matching.

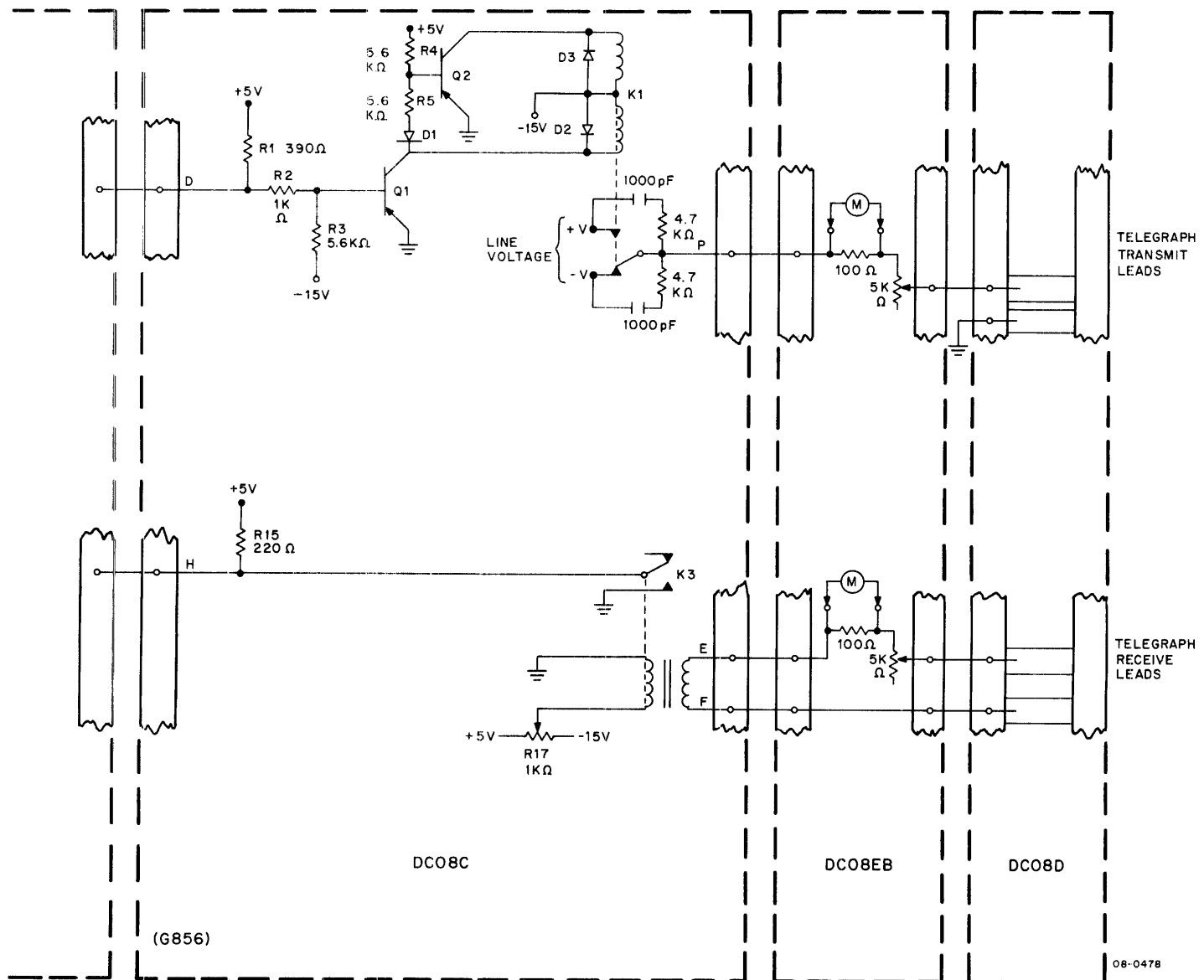

Figure 4-1 TLSSO Transmit/Receive Line Schematic Diagram

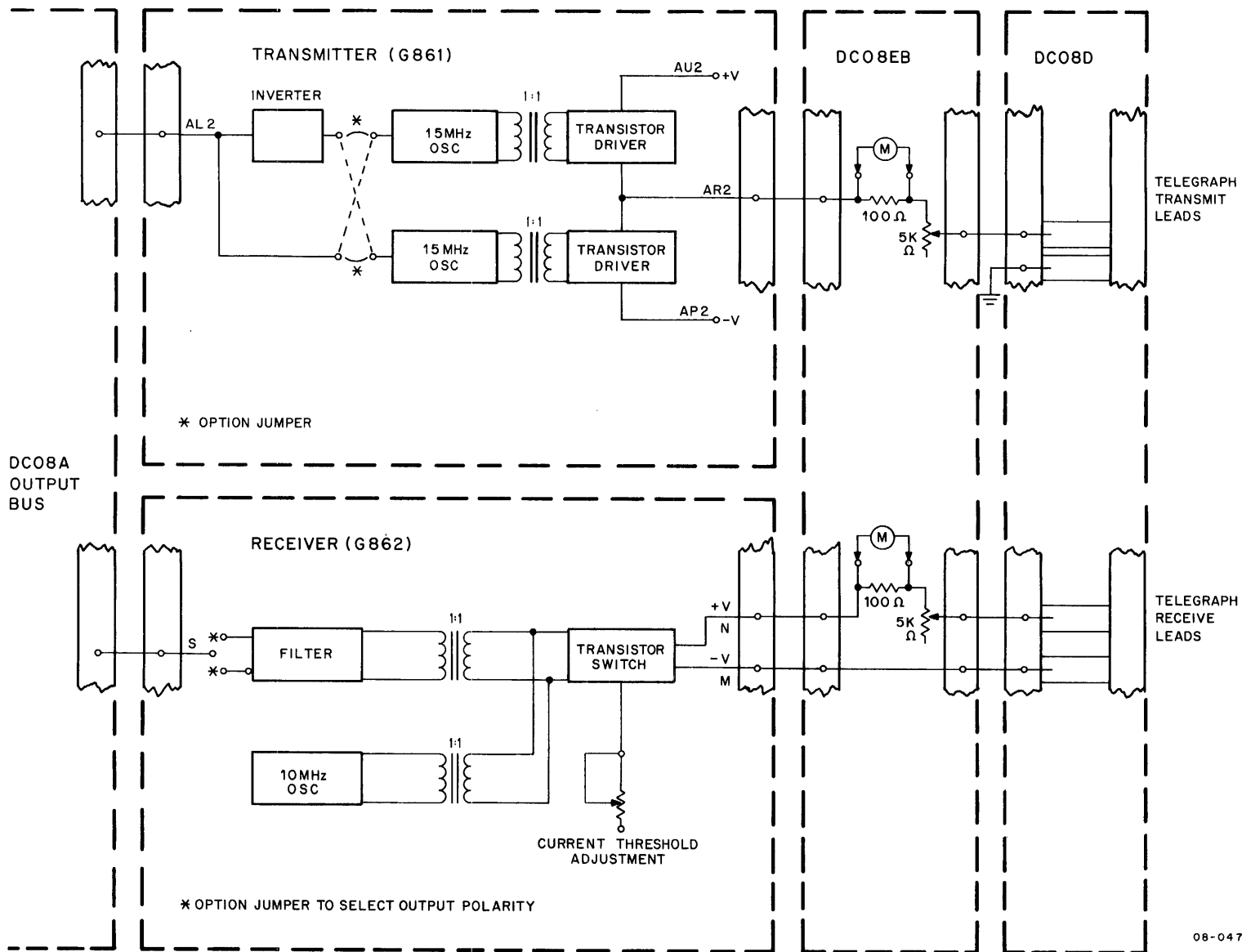

Figure 4-2 TLSO Transmit/Receive Line Simplified Schematic Diagram Using the DC08CM Module

4.2.2 Receiver

Operation of the receive lines is somewhat less complicated. During the quiescent SPACE state, the voltage potential across potentiometer R17 passes current through the coil of relay K3 such that the contact arm is held against the open contact, providing a +3V SPACE signal to the computer, via the DC08A. When a telegraph MARK signal is received at the DC08D Terminator Panel, it causes a current to pass through the coil of relay K3 in the opposite direction (one end of the coil is grounded by the telephone company outside of the DC08D Terminator Panel). Under these current conditions, the contact arm is switched to ground, and this 0V MARK signal is supplied to the computer for the duration of the input telegraph MARK signal. Operation of the DC08EB option is identical to that explained in the preceding paragraph.

4.3 OPERATION OF DC08CS

A functional block diagram of one transmit line and one receive line is shown in Figure 4-2. Figure 4-2 illustrates the content of the G861 Transmitter Module and the G862 Receiver Module and the manner in which line level conversion is accomplished.

4.3.1 Transmitter

The G861 Transmitter Module contains an inverter, two 15-MHz oscillators, one-to-one pulse transformers, and transistor driver circuits. The input signal, illustrated in Figure 4-3(a) is received from the DC08A Serial Line Multiplexer unit. The input signal from the DC08A is divided into two paths. One path goes through an inverter circuit, while the other path goes around the inverter circuit. Each path connects the incoming TTL signal (one inverted) to a high frequency oscillator, where pulse modulation takes place. There is an option, whereby the input leads to the oscillators can be interchanged, to accommodate any data polarity incompatibilities of the receiving device. The modulated signals are then coupled through a one-to-one transformer, and in the second winding the signal is demodulated. One of the modulated signals is illustrated in Figure 4-3(b). The other signal is identical, except that it is inverted. Each signal is placed on a corresponding negative or positive driver, thereby switching the signals on and off. The output signal illustrated in Figure 4-3(c), swings from a negative voltage to a positive voltage, consistent with the requirements of the telegraph line device.

The 15-MHz oscillator is required to couple energy through the low Q transformers, which provide the necessary isolation between the high-voltage output and the low-voltage input.

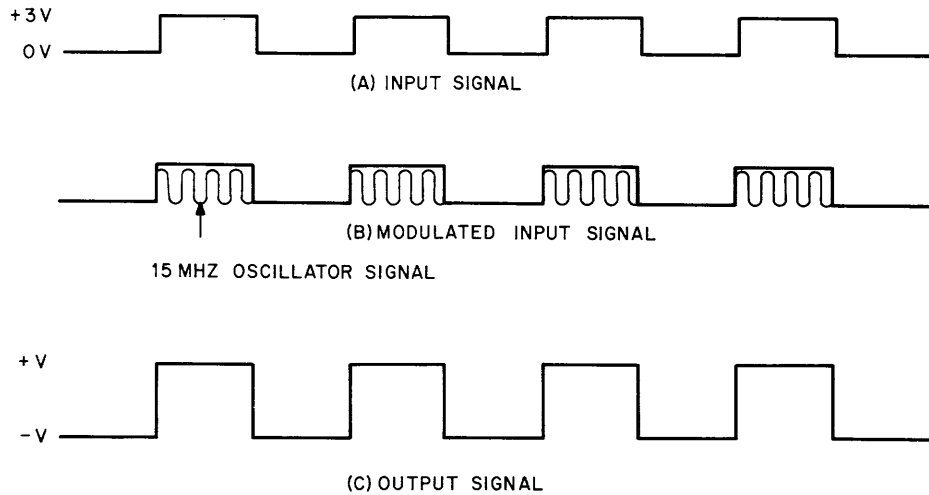

08-0472

Figure 4-3 Representative Waveforms

4.3.2 Receiver

The G862 Receiver Module contains a transistor switch, one-to-one pulse transformers, a 10-MHz oscillator, and a filter network. It receives an input signal from telegraph lines and transforms this signal to MARK and SPACE levels consistent with the requirements of the DC08A.

Functionally, the operation of the receiver is very similar to the transmitter, except that the output signal shown in Figure 4-3 is now the input signal, and so on. The transistor switch receives the telegraph line signals and transforms them into the necessary logic levels required by DC08A. The 10-MHz oscillator provides the necessary modulation, and the signal is coupled to a filter where the signals become demodulated and passed on to the DC08A unit. There is an option on the receiver to select the output polarity to accommodate devices of different polarity. The transformer is used for isolation between the input and the output. A current threshold adjustment is also provided to allow the current to operate at 5-mA to 75-mA threshold levels. This adjustment is necessary so that the module can operate under a variety of line conditions.

5.1 GENERAL

Maintenance procedures for the TLSO require the use of a DC08C tester with six signal cables (W023) and a diagnostic program MAINDEC-8I-D8AB. In addition, for European-Australian systems where the power supplies are provided by DEC, a 793/793A Power Supply and a 893 Fuse Panel are required.

5.2 DC08CS TEST DESCRIPTION

All lines are connected between the DC08C/DC08CS and the tester as indicated in the illustration of a typical test connection for one line (see Figure 5-1). Connections to both the DC08C and DC08CS are identical. The tester has a 2.2K-series current-limiting resistor for each line, which limits the receive circuit current to a value normally used in operation.

CAUTION

Under no circumstances should the input and output be connected without a current-limiting resistor in series with the line.

5.3 DC08C/DC08CS TEST PROCEDURES

All tests must be made on the DC08A as outlined in MAINDEC-8I-D8AB before performing any tests on either the DC08C or the DC08CS. For bipolar systems using the 793/793A Power Supply and the 893 Fuse Panel, connect the DC08C tester to the DC08C/DC08CS as shown in Figure 2-3(a), and perform the tests as described in MAINDEC-8I-D8AB. For neutral systems using power supplied by telephone company facilities, connect the equipment as shown in Figure 2-3(b), using the tester's built-in 62V power supply, and perform the tests as outlined in MAINDEC-8I-D8AB.

When the tests in MAINDEC-8I-D8AB have identified the faulty line, readjust the bias voltage according to Step 17 in Chapter 2. If adjustment is not possible, remove and replace the module, and rerun these tests outlined in MAINDEC-8I-D8AB.

CAUTION

Turn power off prior to removing and replacing modules.

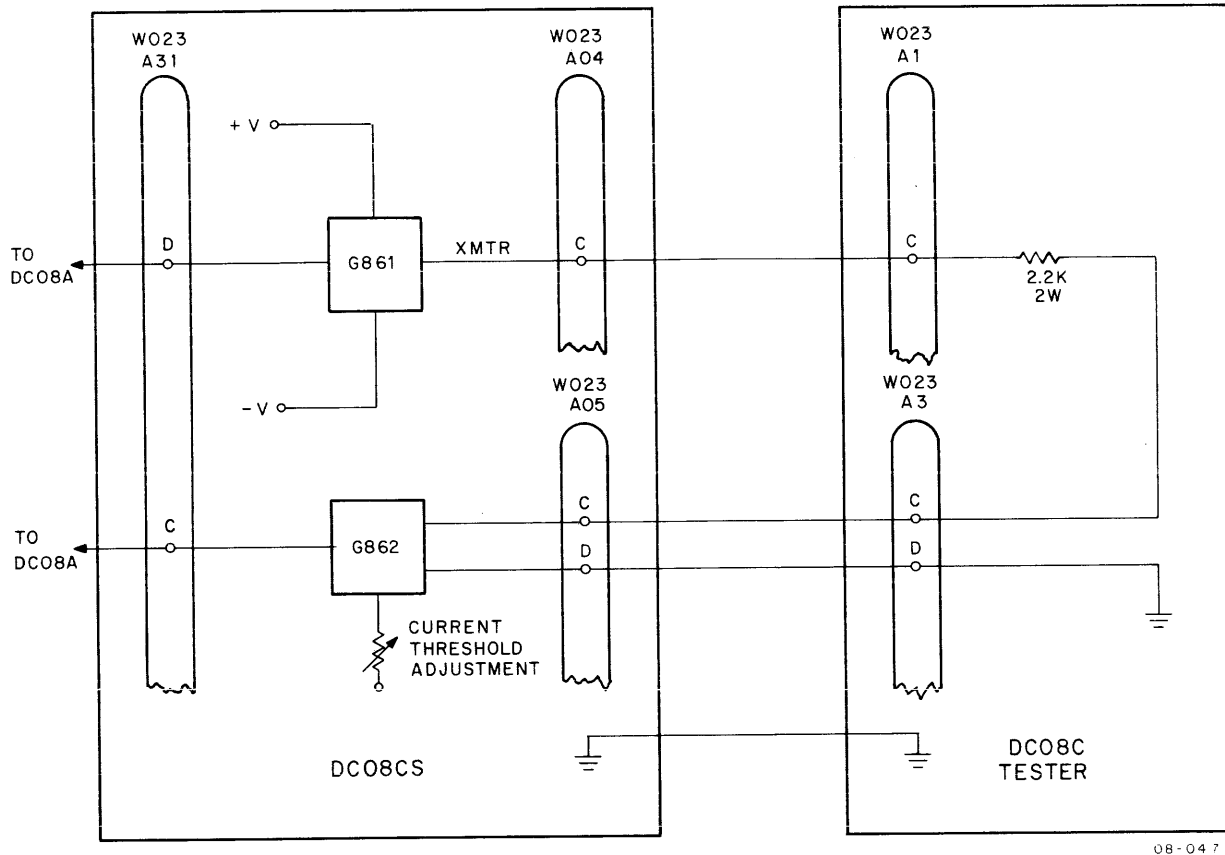

08-0473

Figure 5-1 Test Connections

5.4 DC08D TEST DESCRIPTION

When the DC08C has been fully checked, connect the DC08D to the DC08C or DC08CS as shown in Figure 2-1. Connect the telegraph lines to the terminal blocks as shown on Drawing D-IC-DC08-D-1 (refer to Chapter 6), and perform all tests as specified in MAINDEC-8I-D8BA.

NOTE

To test one or more lines after all telegraph lines are connected to the DC08D terminal blocks (i.e., input jumpered to output), it is necessary to place a series resistor between the transmitter relay output and the receive relay coil to prevent damage to the receive circuit.

CAUTION

The input current to the receiver circuit must not exceed 100 mA.

5.5 DC08EB TEST DESCRIPTION

The DC08EB is tested in the system using the MAINDEC-8I-D8AB diagnostic program. The input is connected to the DC08D output using the DC08EB as the current limiting device.

CHAPTER 6
DIAGRAMS

This chapter contains all pertinent diagrams for the DC08C, DC08CS, DC08D, and DC08EB. Drawings for the DL8/I and the DC08A are included in Chapter 6 of the DC08 Data Communications Equipment Manual (DEC-8I-H80A-D). The following drawings are contained in this chapter.

<u>Drawing Number</u>	<u>Title</u>	<u>Revision</u>	<u>Page</u>
<u>DC08C</u>			
D-BS-DC08-C-2	DC08-C (3 Sheets)	B	6-3
D-MU-DC08-C-3	Module Utilization	A	6-9
C-CS-G856-0-1	Telegraph Level Converter	C	6-11
C-CS-G860-0-1	Telegraph Level Converter	A	6-12
D-CS-DC08-CT-1	DC08-C Tester	C	6-13
<u>DC08CS</u>			
D-BS-DC08-CS-2	Lines 0-15		6-15
D-BS-DC08-CS-3	Lines 16-31		6-17
D-MU-DC08-CS-5	Module Utilization		6-19
C-CS-G861-0-1	Solid State Transmitter	A	6-21
C-CS-G862-0-1	Solid State Receiver G862	A	6-22
<u>Options</u>			
D-CS-DC08-EB-1	Telegraph Adjustment Panel	B	6-23
D-UA-DC08-D-0	Panel Assembly Line Terminator	C	6-25
<u>Power Supplies</u>			
C-CS-3009282-0-0	H-716 Power Supply	A	6-27
C-CS-793-0-1	793 Power Supply		6-28
C-CS-793-A-1	793A 50 Cycle Power Supply		6-29

This drawing and specifications, herein, are the property of Digital Equipment Corporation and shall not be reproduced or copied or used in whole or in part as the basis for the manufacture or sale of items without written permission.

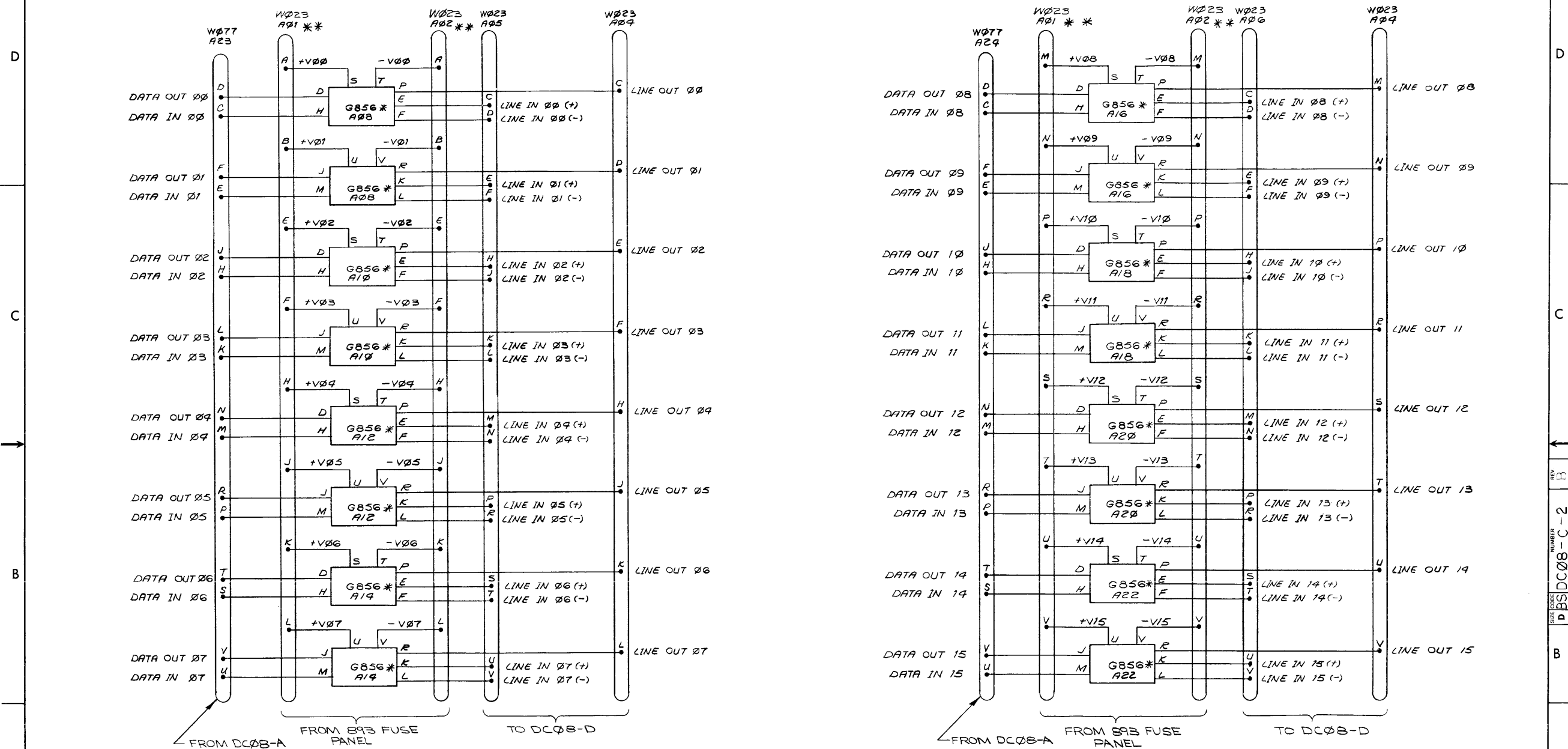

FROM DC08-A FROM 893 FUSE PANEL TO DC08-D

FROM DC08-A FROM 893 FUSE PANEL TO DC08-D

ON SYSTEMS USING 793/793A POWER SUPPLY, A1, A2, B1, B2, ARE W023 CABLE CONNECTORS FROM 893 FUSE PANEL. A3, B3 ARE W023 CABLE CONNECTORS FROM DC08-D TERMINATOR PANEL.

ON SYSTEMS USING COMMON CARRIER POWER, A1, B1 ARE W023 CABLE CONNECTORS FROM DC08-D TERMINATOR PANEL. A2, B2, A3, B3 NOT USED.

* THIS MODULE CAN BE EITHER A G856, OR A G860, DEPENDING ON LINE VOLTAGE REQUIREMENTS.

CAUTION: UNDER NO CIRCUMSTANCES CONNECT OUTPUT TO INPUT WITHOUT A SERIES LIMITING RESISTOR, OF SUCH A VALUE TO LIMIT THE RECEIVE CURRENT TO 100MA.

REV	CHANGE NO.	DATE	BY
1	DC08C-0001	11-1-67	LNAPHI
2	DC08C-0002	11-1-67	LNAPHI
3	DC08C-0003	11-1-67	LNAPHI
4	DC08C-0004	11-1-67	LNAPHI
5	DC08C-0005	11-1-67	LNAPHI
6	DC08C-0006	11-1-67	LNAPHI
7	DC08C-0007	11-1-67	LNAPHI
8	DC08C-0008	11-1-67	LNAPHI

FIRST USED ON OPTION/MODEL	QTY.	DESCRIPTION	PART NO.	ITEM NO.
A-ML-DC08-C				
PARTS LIST				
UNLESS OTHERWISE SPECIFIED				
DRN: <i>Coburn</i> DATE: 3-11-67				
CHKD: <i>W. W. W.</i> DATE: 4-1-67				
ENGR: <i>W. W. W.</i> DATE: 4-1-67				
PROJ. ENG. DATE: 4-1-67				
PROD. DATE: 4-1-67				
NEXT HIGHER ASSY: #				
TITLE: DC08-C (LINE 0-15)				
MATERIAL: #				
FINISH: #				
SCALE: #				
SHEET: 1 OF 3				
SIZE CODE: D B S DC08-C-2				
NUMBER: #				
REV: 3				

This drawing and specifications, herein, are the property of Digital Equipment Corporation and shall not be reproduced or copied or used in whole or in part as the basis for the manufacture or sale of items without written permission.

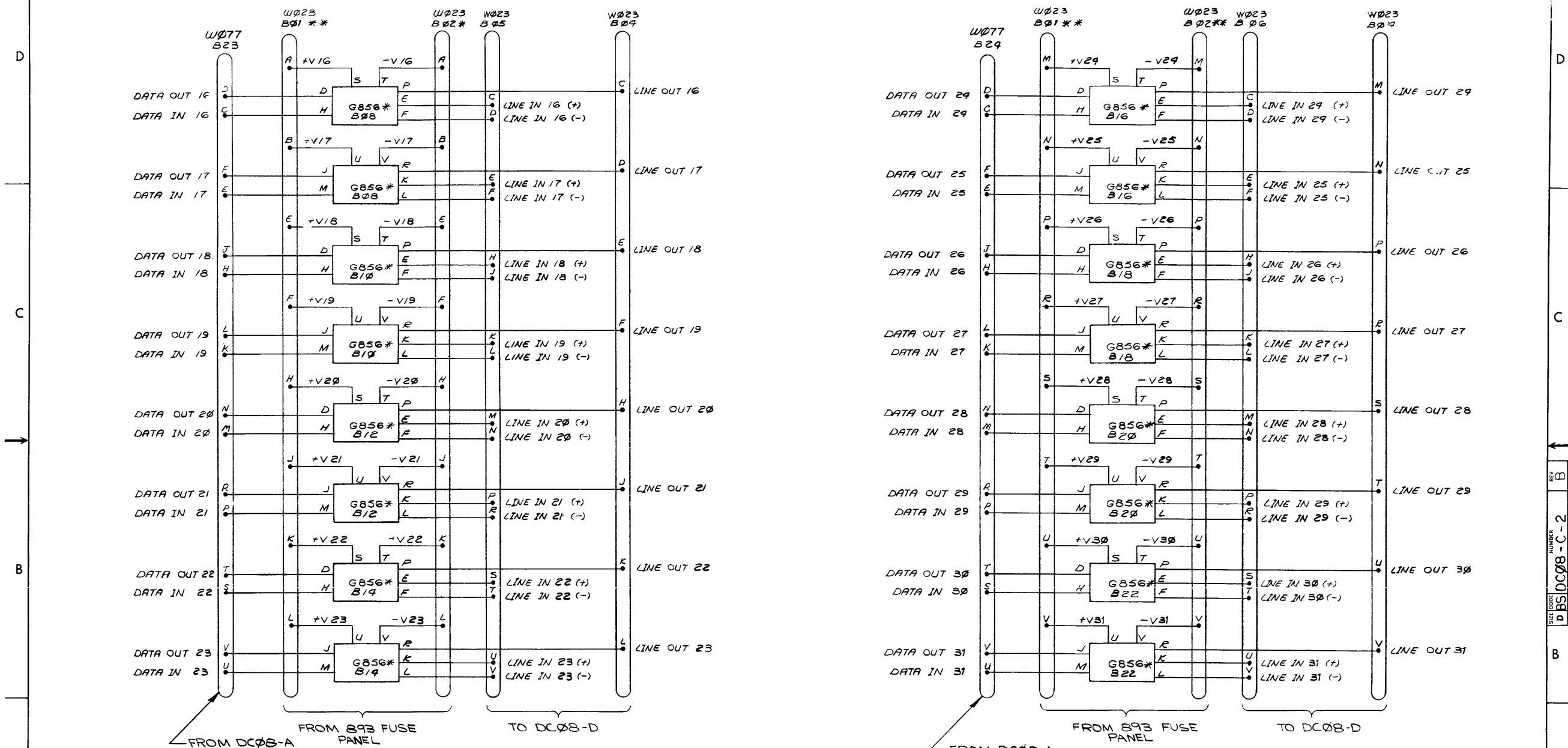

** ON SYSTEMS USING 793/793A POWER SUPPLY, A1, A2, B1, B2 ARE W023 CABLE CONNECTORS FROM 893 FUSE PANEL. A3, B3 ARE W023 CABLE CONNECTORS FROM DC08-D, TERMINATOR PANEL.

ON SYSTEMS USING COMMON CARRIER POWER, A1, B1 ARE W023 CABLE CONNECTORS FROM DC08-D TERMINATOR PANEL. A2, B2, A3, B3 NOT USED.

* THIS MODULE CAN BE EITHER A G856, OR A G860, DEPENDING ON LINE VOLTAGE REQUIREMENTS.
CAUTION: UNDER NO CIRCUMSTANCES CONNECT OUTPUT TO INPUT WITHOUT A SERIES LIMITING RESISTOR, OF SUCH A VALUE, TO LIMIT THE RECEIVE CURRENT TO 100MA

REV.	
CHANGE NO.	
CHK	

FIRST USED ON OPTION/MODEL A-ML-DC08-C	QTY.	DESCRIPTION	PART NO.	ITEM NO.
PARTS LIST				
UNLESS OTHERWISE SPECIFIED	DRN	DATE	DIGITAL EQUIPMENT CORPORATION MAYNARD, MASSACHUSETTS	
UNLESS OTHERWISE SPECIFIED	DATE	DATE	TITLE	
DIMENSION IN INCHES	DATE	DATE	DC08-C (LINES 16-31)	
TOLERANCES	DATE	DATE	SIZE/CODE NUMBER REV.	
DECIMALS = .005	DATE	DATE	DBS DC08-C-2 2	
FRACTIONS = 1/64	DATE	DATE	DIST.	
ANGLES = 0°30'	DATE	DATE		
FINAL SURFACE QUALITY	DATE	DATE		
REMOVE BURRS AND BREAK SHARP CORNERS	DATE	DATE		
MATERIAL	DATE	DATE		
FINISH	DATE	DATE		
SCALE	DATE	DATE		
SHEET 2 OF 3	DATE	DATE		

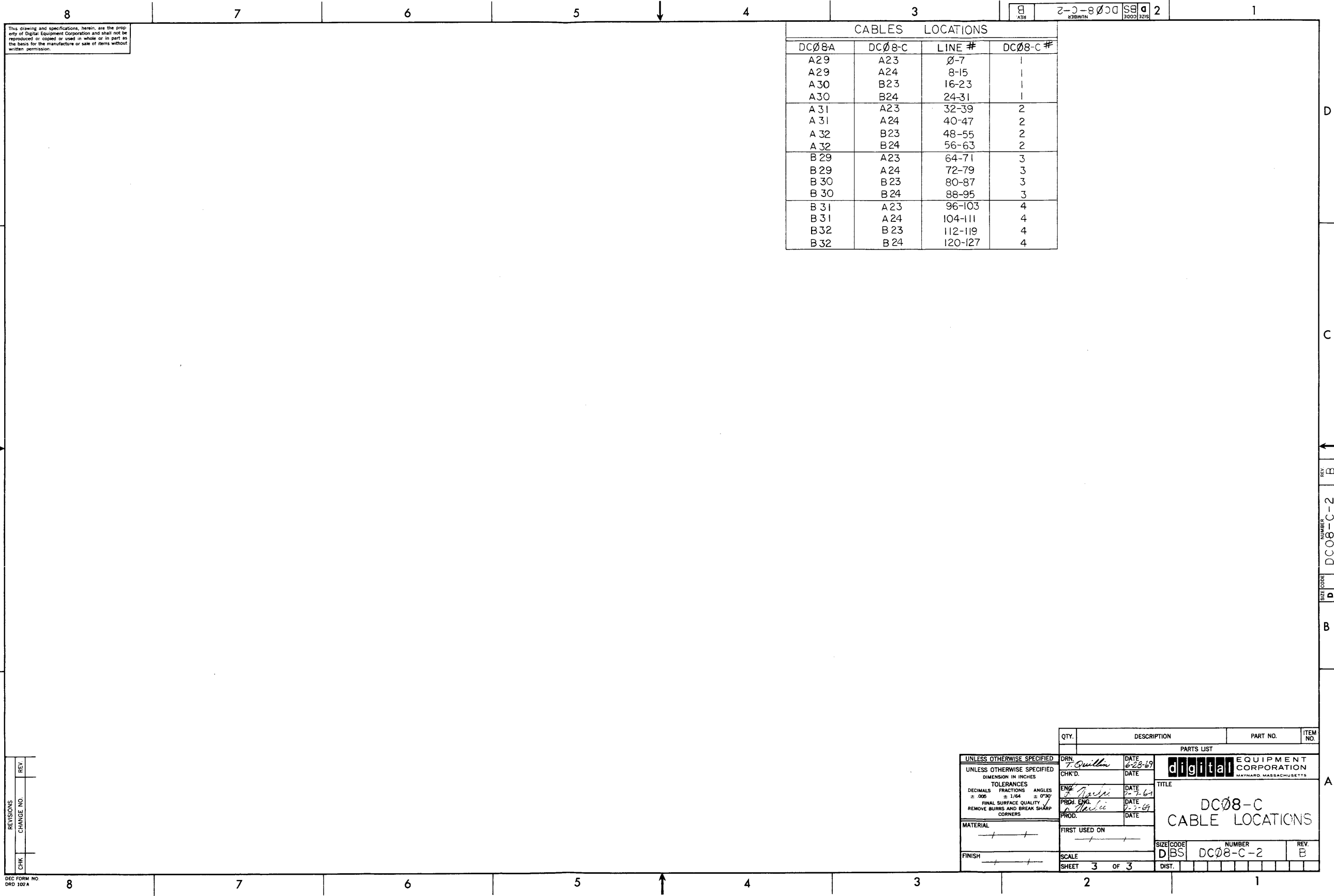

This drawing and specifications, herein, are the property of Digital Equipment Corporation and shall not be reproduced or copied or used in whole or in part as the basis for the manufacture or sale of items without written permission.

CABLES LOCATIONS			
DCØ8A	DCØ8-C	LINE #	DCØ8-C #
A29	A23	Ø-7	1
A29	A24	8-15	1
A30	B23	16-23	1
A30	B24	24-31	1
A31	A23	32-39	2
A31	A24	40-47	2
A32	B23	48-55	2
A32	B24	56-63	2
B29	A23	64-71	3
B29	A24	72-79	3
B30	B23	80-87	3
B30	B24	88-95	3
B31	A23	96-103	4
B31	A24	104-111	4
B32	B23	112-119	4
B32	B24	120-127	4

REV B
NUMBER DCØ8-C-2
SIZE CODE D

REV	
CHANGE NO.	
CHK	

UNLESS OTHERWISE SPECIFIED		DRN	DATE	PARTS LIST	
DIMENSION IN INCHES		<i>T. Quinn</i>	<i>6-23-69</i>	digital EQUIPMENT CORPORATION MAYNARD, MASSACHUSETTS	
TOLERANCES		CHK'D.	DATE	TITLE	
DECIMALS ± .005	FRACTIONS ± 1/64	ENG.	DATE	DCØ8-C CABLE LOCATIONS	
ANGLES ± 0°30'		PROJ. ENG.	DATE	SIZE CODE	NUMBER
FINAL SURFACE QUALITY		PROD.	DATE	DBS	DCØ8-C-2
REMOVE BURRS AND BREAK SHARP CORNERS		FIRST USED ON		DIST.	REV. B
MATERIAL					
FINISH					
SCALE		SHEET 3 OF 3			

DEC FORM NO. DED 102A

This drawing and specifications, herein, are the property of Digital Equipment Corporation and shall not be reproduced or copied or used in whole or in part as the basis for the manufacture or sale of items without written permission.

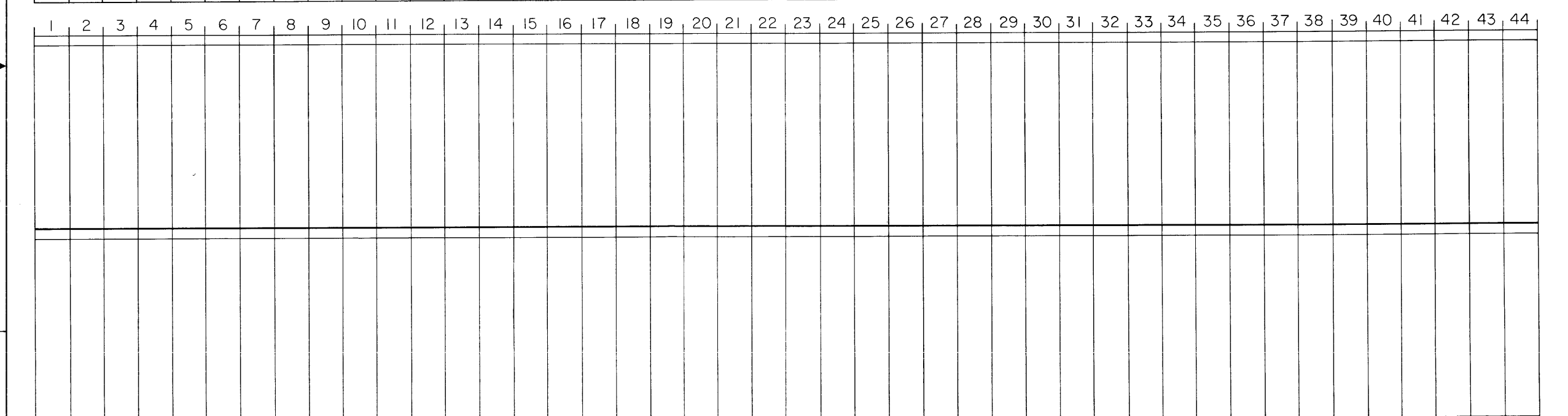
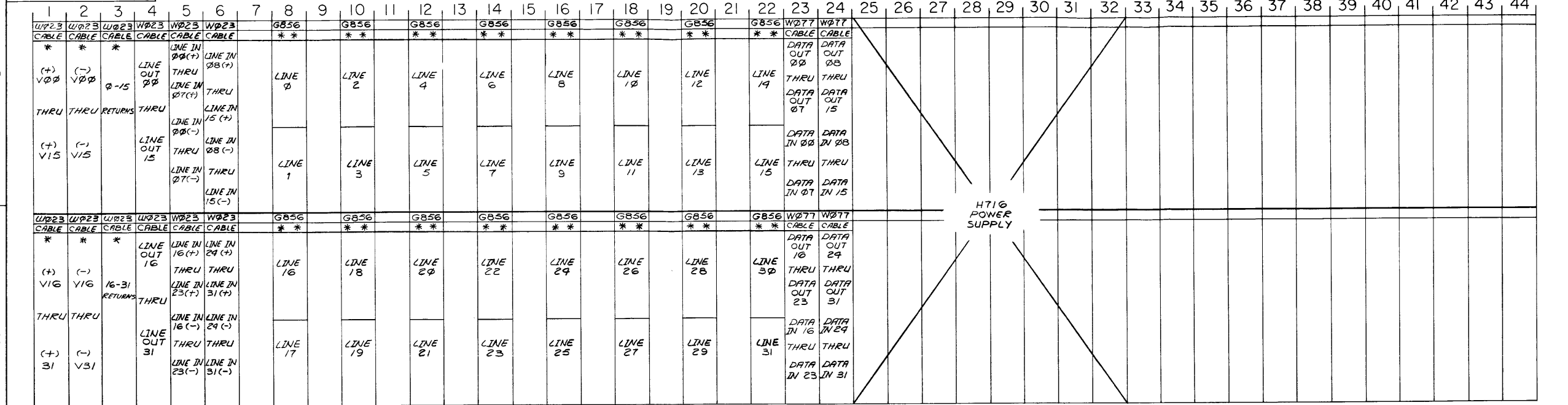

<p>REVISIONS</p> <table border="1"> <tr><td>REV</td><td>1</td></tr> <tr><td>CHG</td><td>DC08-C-0001</td></tr> <tr><td>BY</td><td>T. J. [Signature]</td></tr> <tr><td>DATE</td><td>11/11/69</td></tr> </table>	REV	1	CHG	DC08-C-0001	BY	T. J. [Signature]	DATE	11/11/69	<p>* ON SYSTEMS USING 793/793A POWER SUPPLY, A1, A2, B1, B2 ARE W023 CABLE CONNECTORS FROM B93 FUSE PANEL. A3, B3 ARE CABLE W023 CABLE CONNECTORS FROM DC08-D TERMINATOR PANEL.</p> <p>ON SYSTEMS USING COMMON CARRIER POWER, A1, B1 ARE W023 CABLE CONNECTORS FROM DC08-D TERMINATOR PANEL. A2, B2, A3, B3 NOT USED.</p> <p>** THIS MODULE CAN BE EITHER A G856 OR A G860 DEPENDING ON LINE VOLTAGE REQUIREMENTS</p>	<p>FIRST USED ON OPTION/MODEL</p> <p>DC08-C</p>	<p>UNLESS OTHERWISE SPECIFIED</p> <p>DIMENSION IN INCHES</p> <p>TOLERANCES</p> <p>DECIMALS FRACTIONS ANGLES</p> <p>± .005 ± 1/64 ± 0°30'</p> <p>FINAL SURFACE QUALITY</p> <p>REMOVE BURRS AND BREAK SHARP CORNERS</p>	<p>DRN</p> <p>DATE</p> <p>5-11-69</p> <p>DATE</p> <p>4/19/69</p> <p>DATE</p> <p>4/23/69</p> <p>DATE</p> <p>7/23/69</p>	<p>digital EQUIPMENT CORPORATION</p> <p>WATNARD, MASSACHUSETTS</p> <p>TITLE</p> <p>MODULE UTILIZATION</p>	<p>SIZE CODE</p> <p>DMU DC08-C-3</p> <p>NUMBER</p> <p>DC08-C-3</p> <p>REV</p> <p>A</p>
REV	1													
CHG	DC08-C-0001													
BY	T. J. [Signature]													
DATE	11/11/69													

THIS SCHEMATIC IS FURNISHED ONLY FOR TEST AND MAINTENANCE PURPOSES. THE CIRCUITS ARE PROPRIETARY IN NATURE AND SHOULD BE TREATED ACCORDINGLY. COPYRIGHT 1969 BY DIGITAL EQUIPMENT CORPORATION

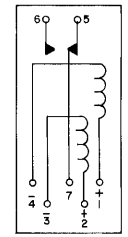
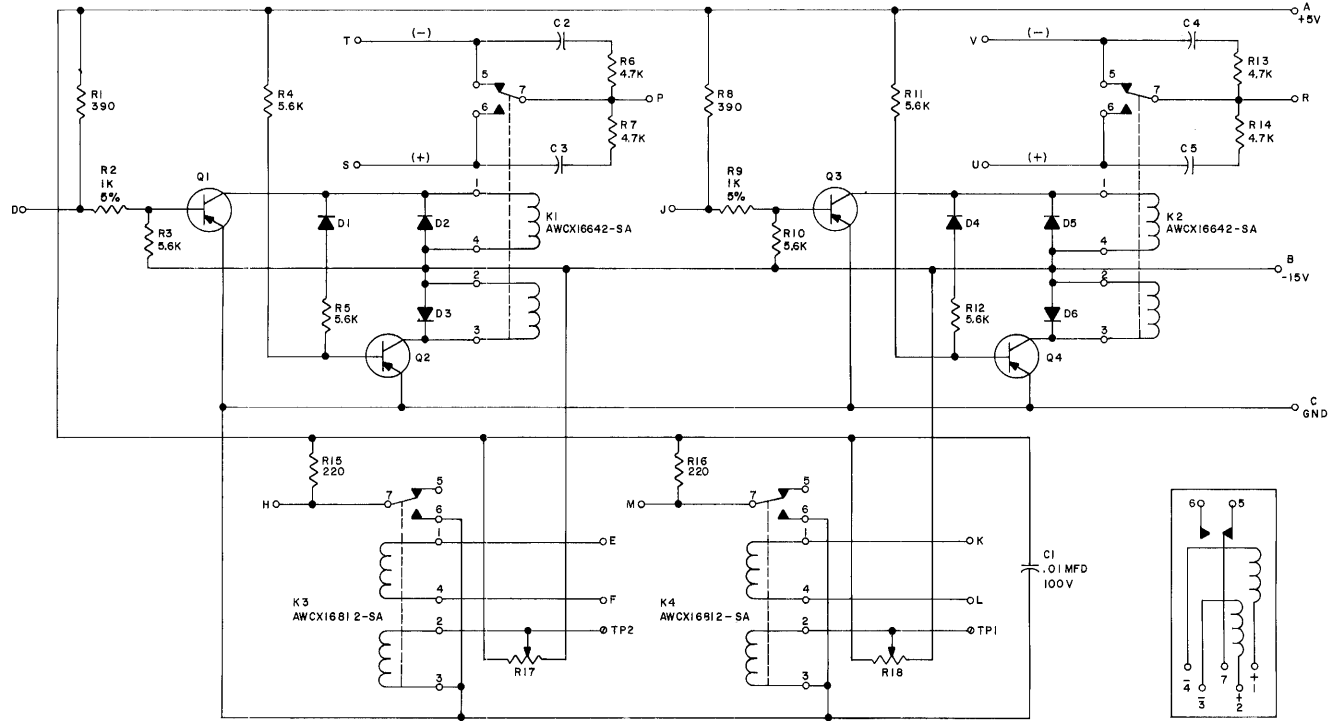

K1, K2, K3, K4
BOTTOM VIEW

UNLESS OTHERWISE INDICATED
TRANSISTORS ARE DEC6534D
RESISTORS ARE 1/4W, 10%
CAPACITORS ARE 1000MMF, 250V
DIODES ARE D664
Ø INDICATES SPLIT LUG
R17 & R18 ARE POTS 260 P 1K

6-11

REVISIONS 1 2 3 4 5 6 7 8 9 10 11 12 13 14 15 16 17 18 19 20 21 22 23 24 25 26 27 28 29 30 31 32 33 34 35 36 37 38 39 40 41 42 43 44 45 46 47 48 49 50		ORN. <i>[Signature]</i> ICHN'D <i>[Signature]</i> ENG. <i>[Signature]</i> PRD. <i>[Signature]</i>	DATE 10-28-69 DATE 12-18-69 DATE 12/18/69	TRANSISTOR & DIODE CONVERSION CHART <table border="1"> <tr> <th>DEC</th> <th>EIA</th> <th>DEC</th> <th>EIA</th> </tr> <tr> <td>D664</td> <td>IN3808</td> <td></td> <td></td> </tr> <tr> <td>DEC6534D</td> <td>MPS6534</td> <td></td> <td></td> </tr> </table>	DEC	EIA	DEC	EIA	D664	IN3808			DEC6534D	MPS6534			digital EQUIPMENT CORPORATION MATNARD, MASSACHUSETTS	TITLE TELEGRAPH LEVEL CONVERTER G856 NUMBER 6856-0-1 PRINTED CIRCUIT REV. B C
DEC	EIA	DEC	EIA															
D664	IN3808																	
DEC6534D	MPS6534																	

DEC FORM NO 100 11/67

REV. C
NUMBER 6856-0-1
SIZE C CS

THIS SCHEMATIC IS FURNISHED ONLY FOR TEST AND MAINTENANCE PURPOSES. THE CIRCUITS ARE PROPRIETARY IN NATURE AND SHOULD BE TREATED ACCORDINGLY. COPYRIGHT 1968 BY DIGITAL EQUIPMENT CORPORATION

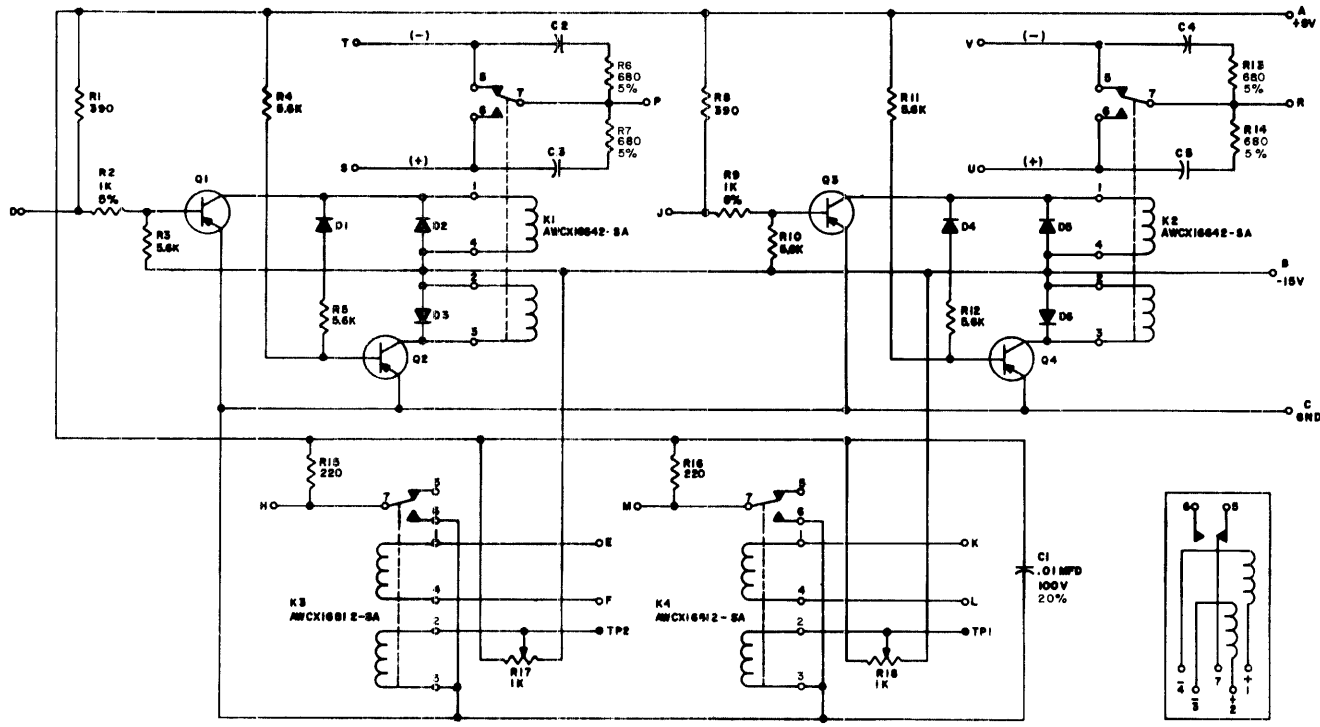

UNLESS OTHERWISE INDICATED
 TRANSISTORS ARE DEC6834D
 RESISTORS ARE 1/4W, 10%
 CAPACITORS ARE 1000MMF, 250V, 20%
 DIODES ARE D664
 ● INDICATES SPLIT LUM
 POTS ARE # 260P
 USE THE ETCH BOARD OF THE G856

6-12

REV. NO.	1
DATE	11/13/68
BY	W. H. HARRIS
CHKD	W. H. HARRIS
DATE	11/13/68

DATE	DEC 1968
BY	W. H. HARRIS
CHKD	W. H. HARRIS
DATE	11/13/68

TRANSISTOR & DIODE CONVERSION CHART			
DEC	EA	DEC	EA
D664	1N3408		
DEC 6834D	2N3934		

digital	TITLE	TELEGRAPH LEVEL CONVERTER
EQUIPMENT CORPORATION	NUMBER	G860
RAYMOND, MASSACHUSETTS	SIZE	C CS
PRINTED CIRCUIT REV.	REV	A

DIST. # 24,454,435

This drawing and specifications, herein, are the property of Digital Equipment Corporation and shall not be reproduced or copied or used in whole or in part as the basis for the manufacture or sale of items without written permission.

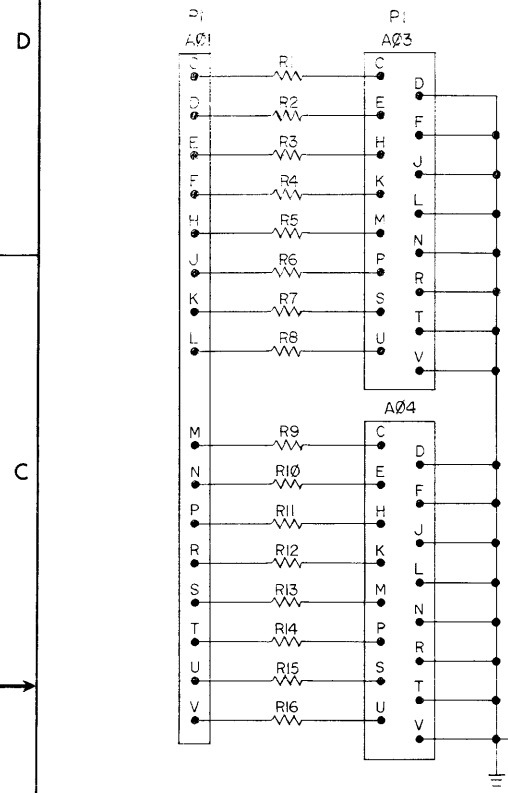

BINDING POST ON FRONT PANEL MUST BE CONNECTED TO THE SYSTEM GROUND

- NOTES:
- IF SYSTEM COMES WITH A 793 OR 793A POWER SUPPLY, DO NOT CONNECT CABLE FROM B1 & B2 TO DC08-C
 - FOR TESTER FRONT PANEL #CABLES SEE DWG A-PL-DC08-CT-0

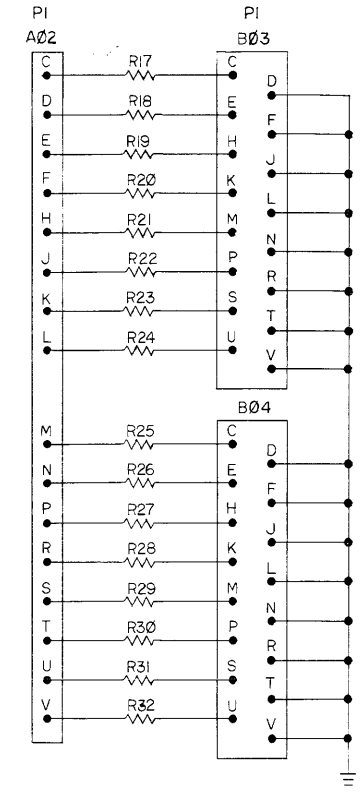

W023 CABLE CONN'S FROM TO

TESTER	DC08-C
A01	A04
A02	B04
A03	A05
A04	A06
B01	A01
B02	B01
B03	B05
B04	B06

SEE NOTE #1

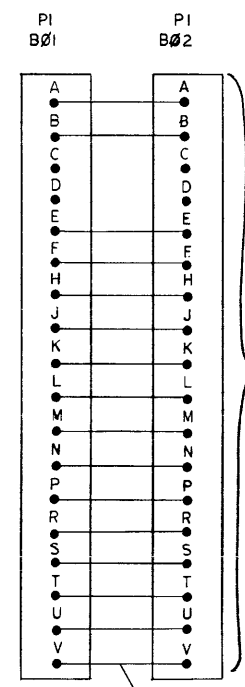

BUSSING STRIPS

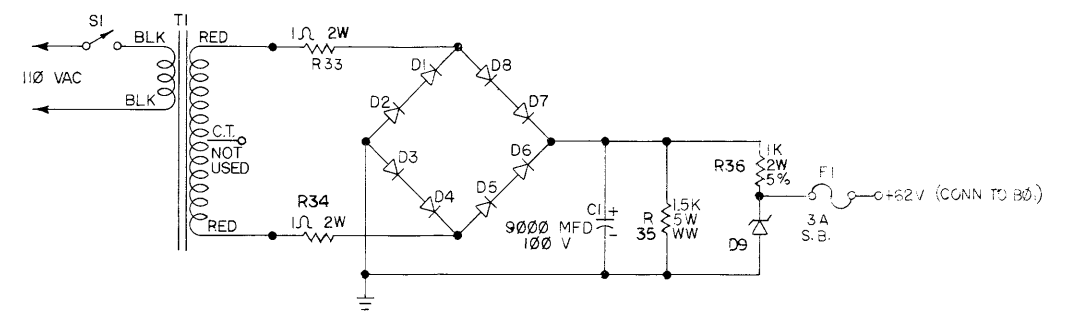

REF DESIGNATION	DESCRIPTION	PART NO.
F1	FUSE 3AMP SLO BLOW	9007218
S1	SWITCH TOGGLE #7505 K3	1201199
T1	TRANS STANCOR RP-2500	
C1	CAP 9000 MFD 100V	1002214
D9	DIODE IN 3039B	1102910
D1 THRU D8	DIODE IN 4003	1103948
R36	RESISTOR 1K 2W 5%	1301352
R35	RESISTOR 1.5K 5W WW	1301397
R33, R34	RESISTOR 1.0 2W	1304607
R1 THRU R32	RESISTOR 2.2K 2W 10%	1300921
P1	199 PIN BLOCK	1202249

REV	
CHANGE NO	
CHK	

FIRST USED ON OPTION/MODEL		PARTS LIST	
DC08-CT TESTER		digital EQUIPMENT CORPORATION MAYNARD MASSACHUSETTS	
UNLESS OTHERWISE SPECIFIED	DATE	TITLE	
DIMENSION IN INCHES	10/15/69	TESTER, DC08-CT	
TOLERANCES	10/21/69	SCALE NONE	
DECIMALS FRACTIONS ANGLES	0/15/69	SHEET 1 OF 1	
= .005 = 1/64 = 0°30'	10/21/69	DIST.	
FINAL SURFACE QUALITY	10/21/69	NUMBER	
REMOVE BURRS AND BREAK SHARP CORNERS	10/21/69	DCS DC08-CT-1	
MATERIAL		REV	
FINISH			

This drawing and specifications, herein, are the property of Digital Equipment Corporation and shall not be reproduced, copied or used in whole or in part as the basis for the manufacture or sale of items without written permission.

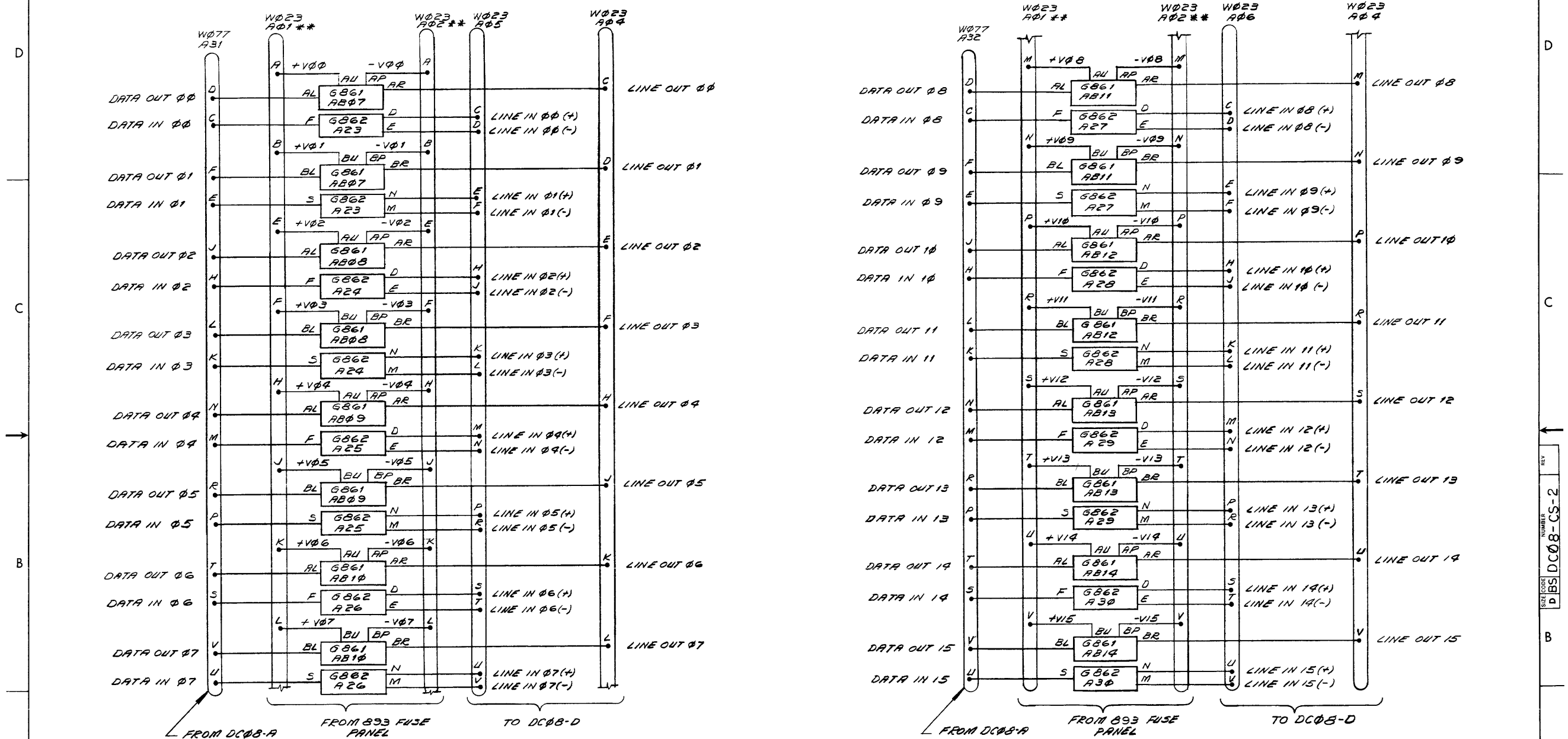

FROM 893 FUSE PANEL TO DC08-D

** ON SYSTEMS USING 793/793A POWER SUPPLY, A1, A2, B1, B2 ARE W023 CABLE CONNECTORS FROM 893 FUSE PANEL. A3, B3 ARE W023 CABLE CONNECTORS FROM DC08-D TERMINATOR PANEL.

ON SYSTEMS USING COMMON CARRIER POWER, A1, B1 ARE W023 CABLE CONNECTORS FROM DC08-D TERMINATOR PANEL. A2, B2, A3, B3 NOT USED.

CAUTION: UNDER NO CIRCUMSTANCES CONNECT OUTPUT TO INPUT WITHOUT A SERIES LIMITING RESISTOR, OF SUCH A VALUE TO LIMIT THE RECEIVE CURRENT TO 100 MA.

REV	
CHK	

FIRST USED ON OPTION/MOD		QTY.	DESCRIPTION	PART NO.	ITEM NO.
DC08-CS					
UNLESS OTHERWISE SPECIFIED		DRN	DATE	PARTS LIST	
DIMENSION IN INCHES		CHKD	DATE	digital EQUIPMENT CORPORATION	
TOLERANCES		ENR	DATE	MAYNARD, MASSACHUSETTS	
DECIMALS	FRACTIONS	PROJ. ENG.	DATE	TITLE	
= .005	= 1/64	A. Tarkenton	2-10-70	LINES 0-15	
ANGLES		PROB.	DATE	SIZE CODE	
= 0°30'		A. Tarkenton	2-10-70	NUMBER	
FINAL SURFACE QUALITY		DATE	2-10-70	REV	
REMOVE BURRS AND BREAK SHARP CORNERS		DATE	2-10-70	SCALE	
MATERIAL		FINISH	SCALE	DIST.	
A-MIL-DC08-CS		SCALE	1	SHEET	
FINISH		SHEET	1 OF 1	DC08-CS-2	

This drawing and specifications herein are the property of Digital Equipment Corporation and shall not be reproduced or copied or used in whole or in part as the basis for the manufacture or sale of items without written permission.

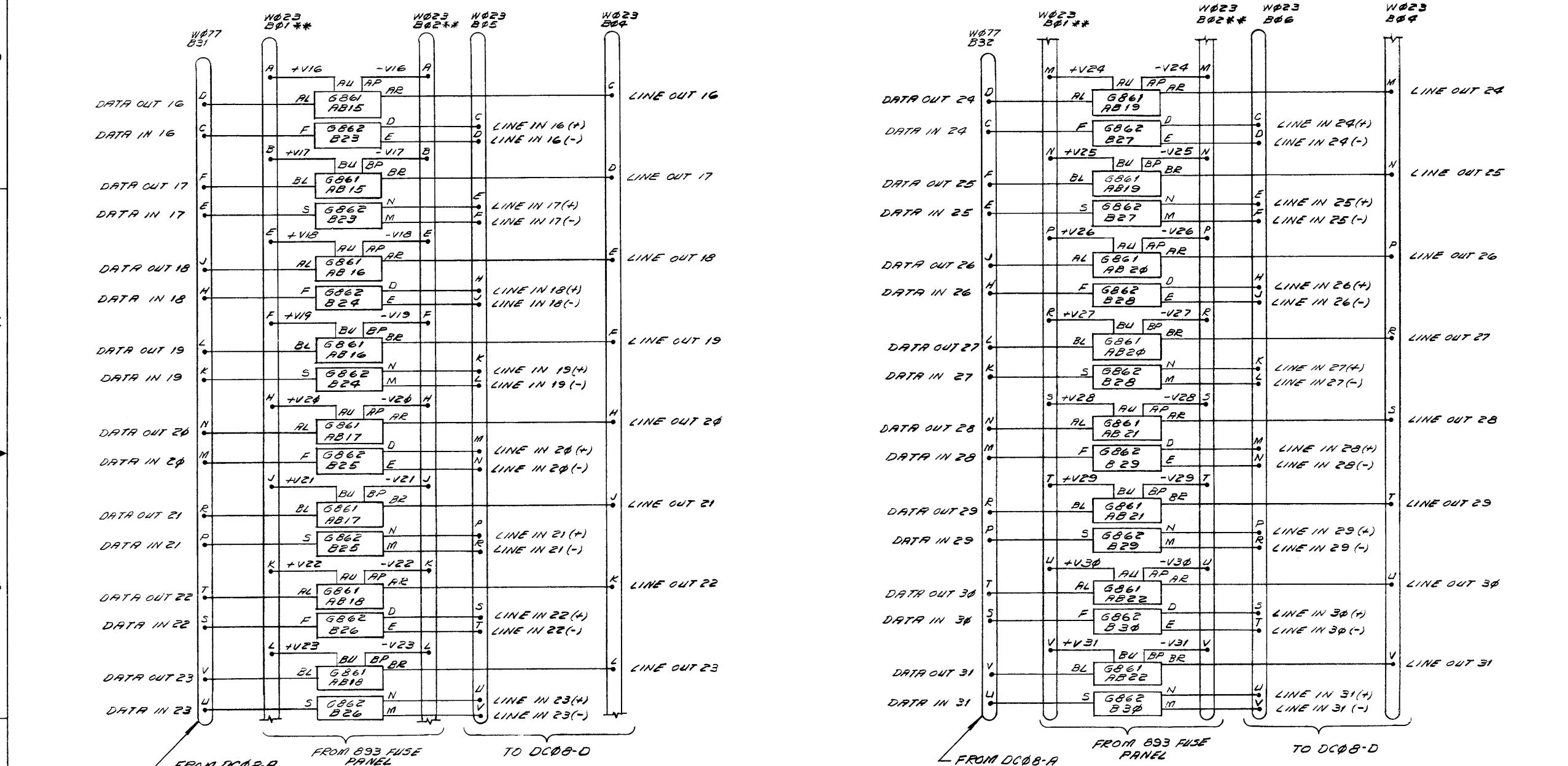

FROM DC08-A FROM 893 FUSE PANEL TO DC08-D

FROM DC08-A FROM 893 FUSE PANEL TO DC08-D

ON SYSTEMS USING 793/793A POWER SUPPLY, R1, R2, B1, B2 ARE W023 CABLE CONNECTORS FROM 893 FUSE PANEL. R3, B3 ARE W023 CABLE CONNECTORS FROM DC08-D TERMINATOR PANEL.

ON SYSTEMS USING COMMON CARRIER POWER, R1, B1 ARE W023 CABLE CONNECTORS FROM DC08-D TERMINATOR PANEL. R2, B2, R3, B3 NOT USED.

CAUTION: UNDER NO CIRCUMSTANCES CONNECT OUTPUT TO INPUT WITHOUT A SERIES LIMITING RESISTOR, OF SUCH A VALUE TO LIMIT THE RECEIVE CURRENT TO 100 μ A.

REV	CHG	NO

FIRST USED ON OPTION MOD	QTY.	DESCRIPTION	PART NO.	ITEM NO.
DC08-CS				
UNLESS OTHERWISE SPECIFIED				
DIMENSION IN INCHES				
TOLERANCES				
DECIMALS	FRACTIONS	ANGLES		
$\pm .005$	$\pm 1/64$	$\pm 0^{\circ}30'$		
FINAL SURFACE QUALITY / REMOVE BURRS AND BREAK SHARP CORNERS				
MATERIAL				
FINISH				
DRAWN: [Signature]		DATE: 1-22-70	PARTS LIST	
CHKD: [Signature]		DATE: 2/9/70	digital EQUIPMENT CORPORATION	
ENGR: [Signature]		DATE: 2-10-70	MAYFORD, MASSACHUSETTS	
PROD. ENGR: [Signature]		DATE: 2-10-70	TITLE	
PROJ. ENGR: [Signature]		DATE: 3-10-70	LINES 16-31	
MATERIAL		NEXT HIGHER ASSY		
FINISH				
SCALE			SIZE CODE	NUMBER
SHEET		OF	DBS	DC08-CS-3
			DIST.	REV.

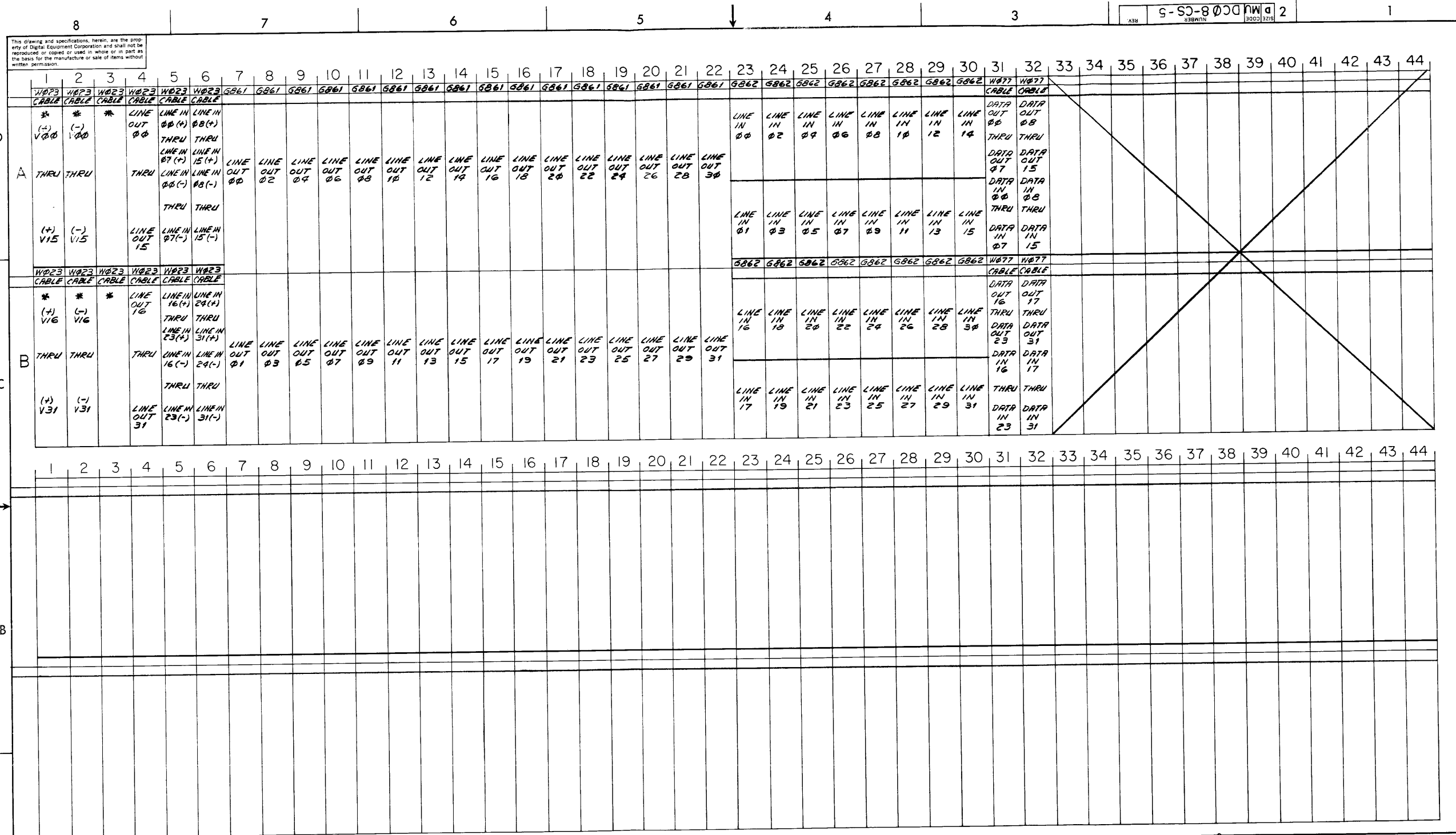

REV	NO
CHG	NO
CHK	

* ON SYSTEMS USING 793/733 A, POWER SUPPLY A1, A2, B1, B2 ARE W023 CABLE CONNECTORS FROM 833 FUSE PANEL. A3, B3 ARE W023 CABLE CONNECTORS FROM DC68-D TERMINATOR PANEL.

ON SYSTEMS USING COMMON CARRIER POWER, A1, B1 ARE W023 CABLE CONNECTORS FROM DC68-D TERMINATOR PANEL. A2, B2, A3, B3 ARE NOT USED.

UNLESS OTHERWISE SPECIFIED	DRN: <i>D</i>	DATE: 1-22-70	digital EQUIPMENT CORPORATION MAYNARD, MASSACHUSETTS
CHECKED: <i>[Signature]</i>	DATE: 1-6-70	TITLE: MODULE UTILIZATION	
TOLERANCES	ENG: <i>[Signature]</i>	DATE: 2-10-70	A-ML-DC08-CS
DECIMALS: ± .005	ANGLES: ± 0°30'	DATE: 2-10-70	
FINAL SURFACE QUALITY: REMOVE BURRS AND BREAK SHARP CORNERS	PROD. ENG: <i>[Signature]</i>	DATE: 2/10/70	SIZE CODE: D MU DC08-CS-5
MATERIAL: <i>[Blank]</i>	NEXT HIGHER ASSY: A-ML-DC08-CS	SCALE: <i>[Blank]</i>	NUMBER: <i>[Blank]</i>
FINISH: <i>[Blank]</i>	SCALE: 1"=1"	SHEET: 1 OF 1	REV: <i>[Blank]</i>
FIRST USED ON OPTION/ MODEL: DC08-CS			DIST: <i>[Blank]</i>

DEC FORM NO. DRG 105

THIS SCHEMATIC IS PROVIDED ONLY FOR TEST AND MAINTENANCE PURPOSES. THE CIRCUITS ARE PROPRIETARY IN NATURE AND SHOULD BE TREATED ACCORDINGLY. COPYRIGHT 1969 BY DIGITAL EQUIPMENT CORPORATION.

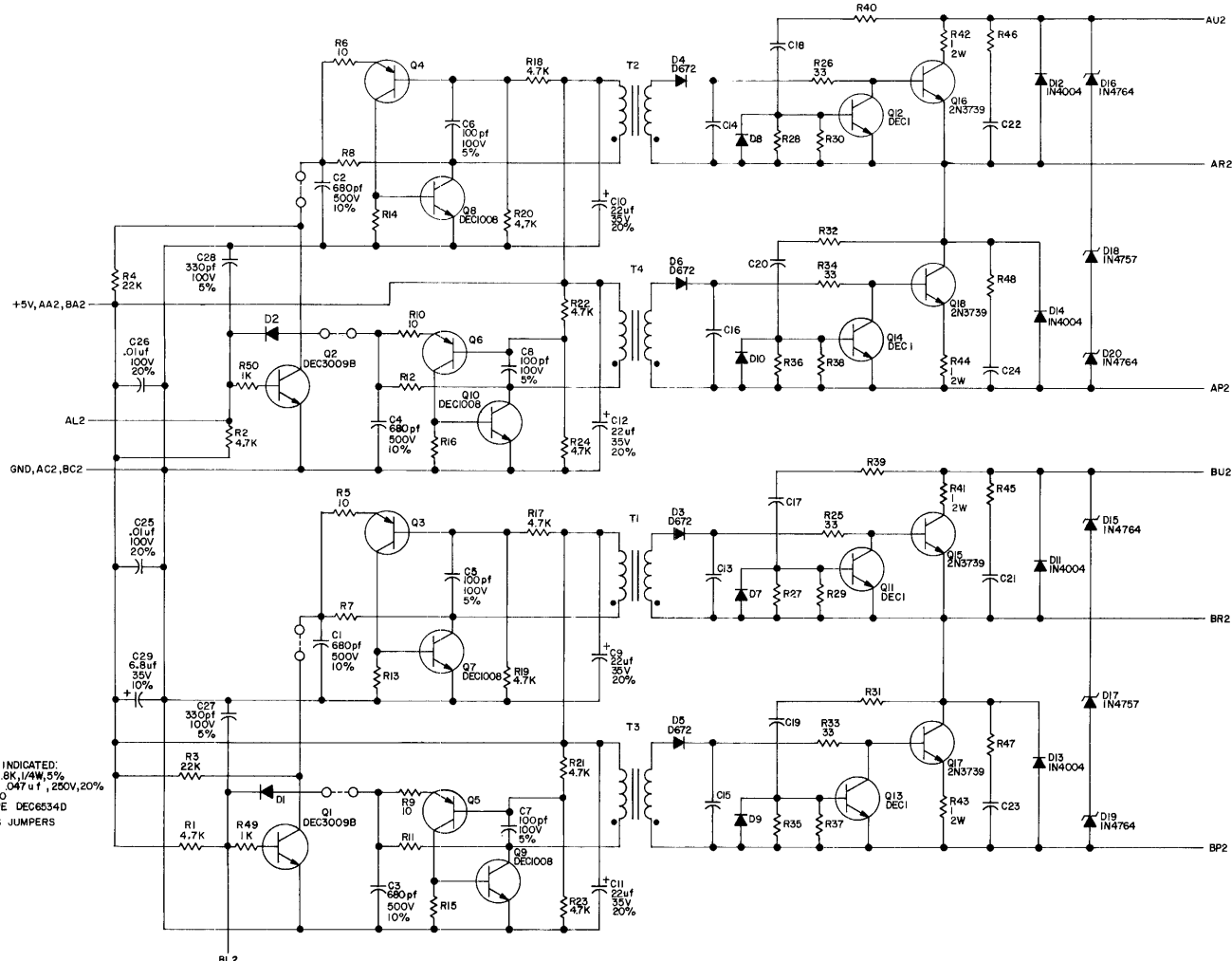

UNLESS OTHERWISE INDICATED:
RESISTORS ARE 1/8W, 5%
CAPACITORS ARE .047 u f, 250V, 20%
DIODES ARE D600
TRANSISTORS ARE DEC6534D
○--○ INDICATES JUMPERS

REV	1
DATE	1/17/71
BY	W. J. ...
CHKD	...
APPROVED	...

ORIGIN: *W. J. ...*
DATE: *12-1-70*
CHK'D: *W. J. ...*
DATE: *2-22-70*
ENG: *W. J. ...*
DATE: *2-12-70*
PRG'D: *W. J. ...*
DATE: *2/2/71*

TRANSISTOR & DIODE CONVERSION CHART			
DEC	EIA	DEC	EIA
D600	IN4009	DEC6534D	MP98034D
D872	IN3693	DEC3009B	2N3009B
IN4004	SAME	DEC1008	1N1008
IN4764	SAME	2N3739	SAME
IN4757	SAME	DEC1	2N3721

digital
EQUIPMENT CORPORATION
MAYFORD, MASSACHUSETTS

TITLE: SOLID STATE TRANSMITTER G861
SIZE: C CODE: CS NUMBER: G861-0-1 REV: A
PRINTED CIRCUIT REV: **A|B**

REV. A
NUMBER G861-0-1
CSC

THIS SCHEMATIC IS FURNISHED ONLY FOR TEST AND MAINTENANCE PURPOSES. THE CIRCUITS ARE PROPRIETARY IN NATURE AND SHOULD BE TREATED ACCORDINGLY. COPYRIGHT 1970 BY DIGITAL EQUIPMENT CORPORATION

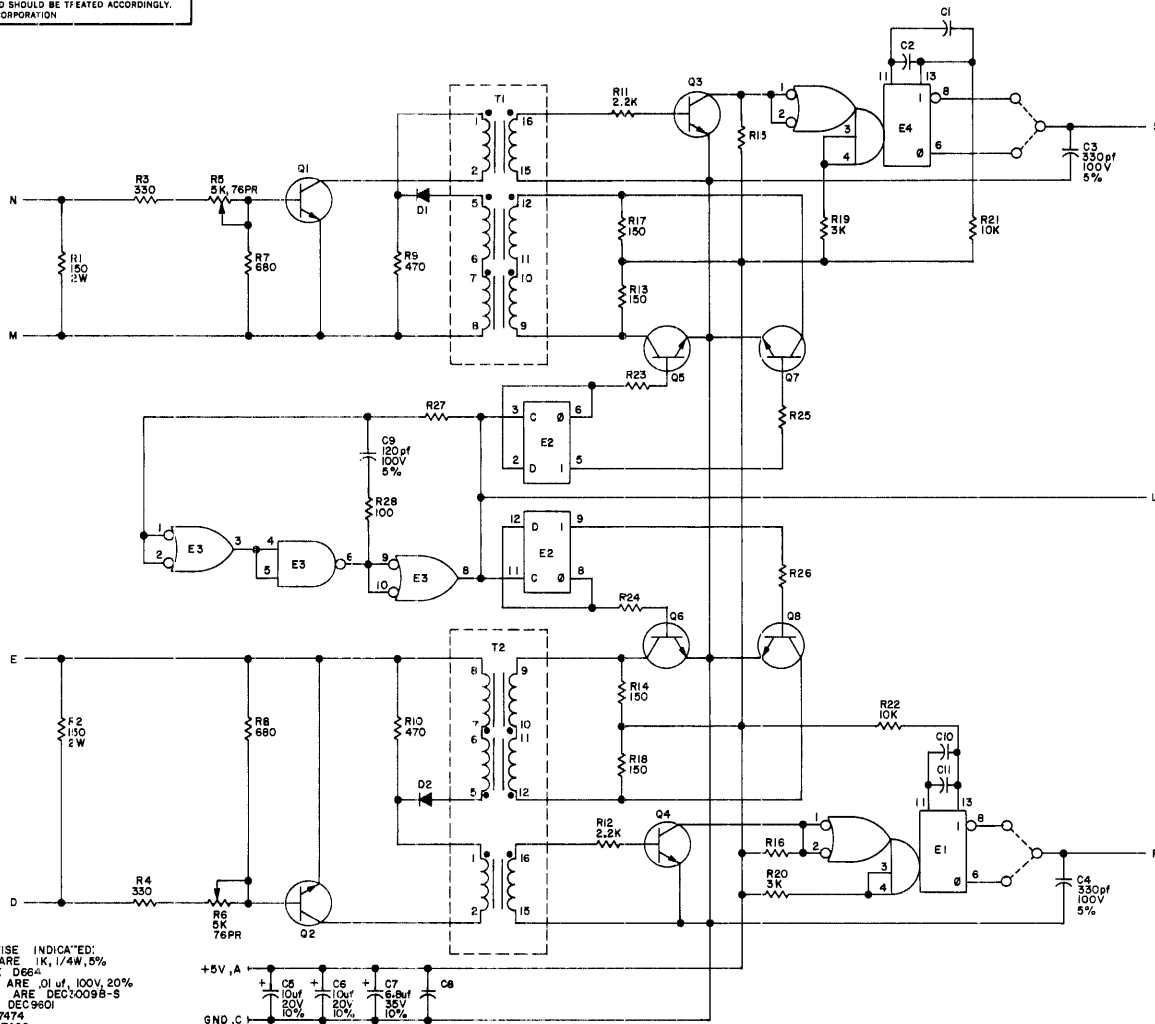

UNLESS OTHERWISE INDICATED:
 RESISTORS ARE 1/4W, 5%
 DIODES ARE D664
 CAPACITORS ARE .01 uF, 100V, 20%
 TRANSISTORS ARE DEC7009B-S
 E1, E4 ARE DEC9601
 E2 IS DEC7474
 E3 IS DEC7400
 PIN 7 ON EACH IC = GND
 PIN 14 ON EACH IC = +5V
 O--O INDICATES JUMPER OPTIONS
 T1 & T2 ARE PULSE TRANSFORMER (1609651)

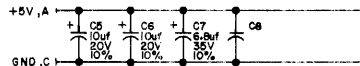

6-22

REV.	CHG. NO.	REV.
1	00001	A
2	00002	B

DRN. ALLAN RITCEY DATE 3-9-70
 G1/8/70
 DATE 3-11-70
 DATE 5-13-70
 PROD. DATE

TRANSISTOR & DIODE CONVERSION CHART			
DEC	EIA	DEC	EIA
D664	1N3806		
DEC3009B-S	2N3009B		

digital
 EQUIPMENT CORPORATION
 MAYFORD, MASSACHUSETTS

TITLE: SOLID STATE RECEIVER G862
 SIZE C CODE CS NUMBER G862-0-1 REV B
 PRINTED CIRCUIT REV. B

REV. B
 NUMBER G862-0-1
 SIZE CODE C CS

THIS SCHEMATIC IS FURNISHED ONLY FOR TEST AND MAINTENANCE PURPOSES. THE CIRCUITS ARE PROPRIETARY IN NATURE AND SHOULD BE TREATED ACCORDINGLY. COPYRIGHT 1963 BY DIGITAL EQUIPMENT CORPORATION.

DCS DC08-EB-1

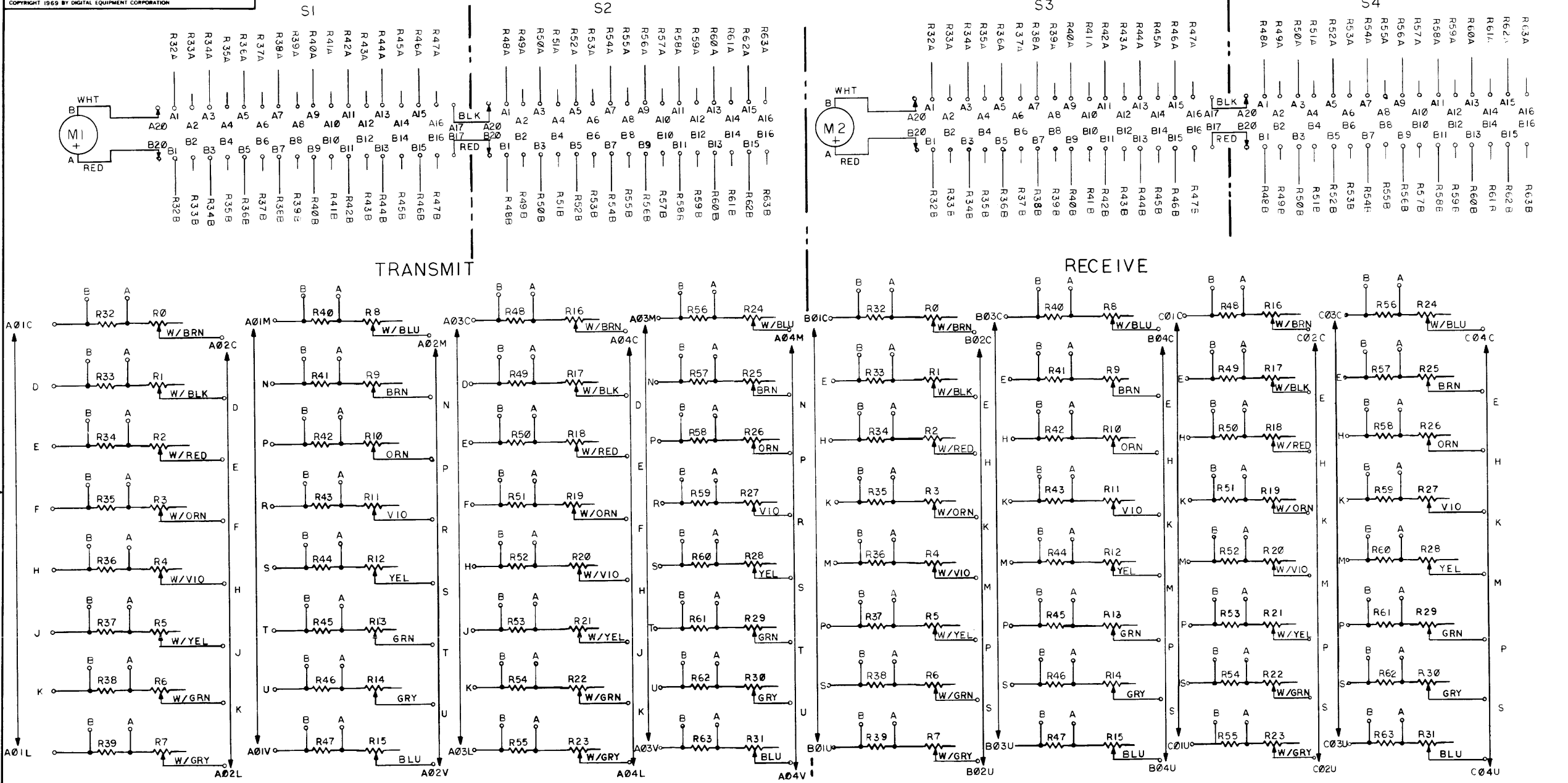

DC08-C	DC08-EB	DC08-D
A04	A1	—
—	A2	P1
B04	A3	—
—	A4	P5
A05	B1	—
—	B2	P3
A06	B3	—
—	B4	P4
B05	C1	—
—	C2	P7
E06	C3	—
—	C4	P8

DC08-C	DC08-EB	DC08-D
A01	D1	—
—	D2	P2
B01	D3	—
—	D4	P6

THESE 4 SLOTS USED ONLY ON COMMON CARRIER SUPPLIED POWER. OTHERWISE THEY ARE NOT USED.

R32 R63	RES. 100 OHM 10W 5% W W	1305774
R0-R31	POT 5K 12-1/2W 1C% W W	1309669
S1, S2, S3, S4	SWITCH *MS-20-2 J.B.T. INST	1205402
M1, M2	METER *3-C2 BEEDE	1209670
REF DESIGNATION	DESCRIPTION	PART NO.

REV	DATE	BY	CHKD
1	11/16/63	W. J.
2	11/16/63

TRANSISTOR & DIODE CONVERSION CHART			
DEC	EIA	DEC	EIA

PARTS LIST		TITLE	
digital TELEGRAPH ADJ PNL		EQUIPMENT CORPORATION	
SIZE	CODE	NUMBER	REV
D	CS	DC08-EB-1	E

DCS FORM NO. 988 118

REV B
NUMBER DC08-EB-1

This drawing and specifications, herein, are the property of Digital Equipment Corporation and shall not be reproduced or copied or used in whole or in part as the basis for the manufacture or sale of items without written permission.

- NOTES:
1. GANGING ROD ITEM #14 WILL CONNECT SEE THRU COVER ITEM #13 IN GROUPS OF FOUR, 1-4, 5-8, 9-12, 13-16.
 2. TO BE MARKED IN CHECK-OUT AREA WITH INDELIBLE PEN NO'S 1-16 ON TERM STRIPS TB1-TB8.
 3. AFTER ASSEMBLY, MARK ALL CONNECTOR CARDS WITH RESPECTIVE PART NUMBERS.

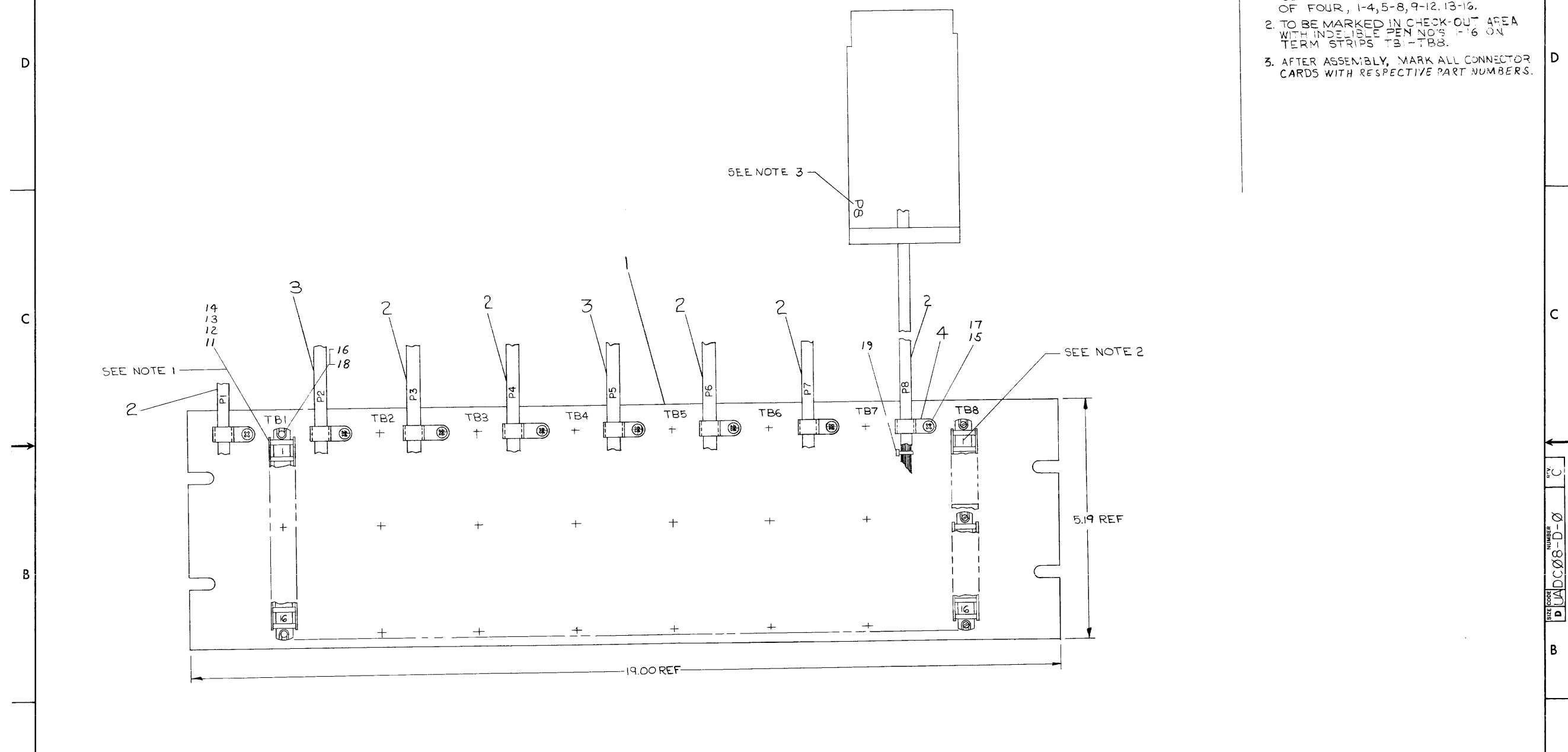

REV.	CHG. NO.	DATE	BY	APP.
1	DCOBD-00002	11-9-69	A. CHADDA	
2	DCOBD-00004	11-11-69	T. W. ...	
3	DCOBD-00005	11-11-69	F. V. ...	
4	DCOBD-00005	11-11-69	A. ...	

TOLERANCES

DECIMALS

XXX = ± .005

XX = ± .02

X = ± .1

FIRST USED ON OPTION/MODEL	QTY.	DESCRIPTION	PART NO.	ITEM NO.
DCOBD				
PARTS LIST				
UNLESS OTHERWISE SPECIFIED	DRN. <i>F. ...</i>	DATE 11/11/69	digital EQUIPMENT CORPORATION MATHEWASH, MASSACHUSETTS	
UNLESS OTHERWISE SPECIFIED	CHK'D <i>R. ...</i>	DATE 11/22/69		
TOLERANCES	ENG. <i>R. ...</i>	DATE 11/22/69		
FINAL SURFACE QUALITY / REMOVE BURRS AND BREAK SHARP CORNERS	PROJ. ENG. <i>R. ...</i>	DATE 11/11/69		
MATERIAL	PROD. <i>A. ...</i>	DATE 11/11/69	TITLE PANEL ASSY LINE TERMINATOR	
FINISH	NEXT HIGHER ASSY			
SCALE			SIZE CODE	NUMBER
SHEET			DUA	DCOBD-D-0

6-27

This drawing and specifications, herein, are the property of Digital Equipment Corporation and shall not be reproduced or copied or used in whole or in part as the basis for the manufacture or sale of items without written permission.

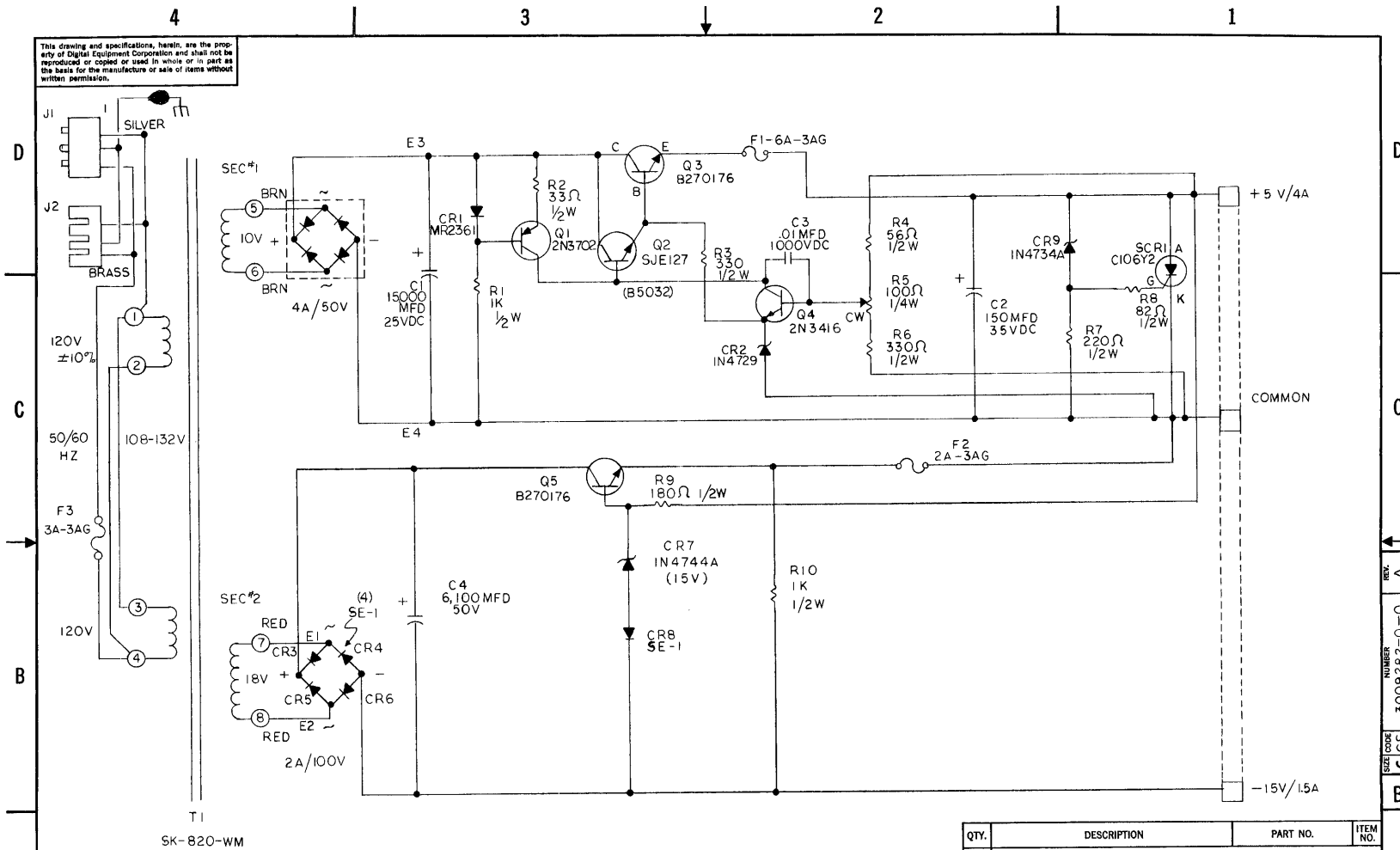

REVISIONS	REV.	DATE
CHK	CHANGE NO.	A
HT716-0001		
M. ARSENAULT		

NOTE:
THIS CIRCUIT SCHEMATIC
HAS BEEN REDRAWN WITH
THE PERMISSION OF
WANLESS ELECTRIC CO.
SEE WANLESS DRAWING
NUMBER C-101418, MODEL
C-148

UNLESS OTHERWISE SPECIFIED	DRN	DATE
UNLESS OTHERWISE SPECIFIED	CHRP	DATE
DIMENSION IN INCHES	ENG	DATE
TOLERANCES	PROJ. ENG.	DATE
DIGIMALS FRACTIONS ANGLES	PRD.	DATE
±.005 ± 1/64 ± 0°30'		
FINAL SURFACE QUALITY		
REMOVE BURRS AND BREAK SHARP CORNERS		
MATERIAL		
FINISH		

QTY.	DESCRIPTION	PART NO.	ITEM NO.
PARTS LIST			
digital EQUIPMENT CORPORATION MAYNARD, MASSACHUSETTS			
TITLE H-716.P.S.			
SCALE	SHEET	DIST.	
SIZE CODE	NUMBER	REV.	
C CS	3009282-0-0	A	

REV. A
NUMBER 3009282-0-0
SIZE CODE C CS

THIS SCHEMATIC IS FURNISHED ONLY FOR TEST AND MAINTENANCE PURPOSES. THE CIRCUITS ARE PROPRIETARY IN NATURE AND SHOULD BE TREATED ACCORDINGLY. COPYRIGHT BY DIGITAL EQUIPMENT CORPORATION.

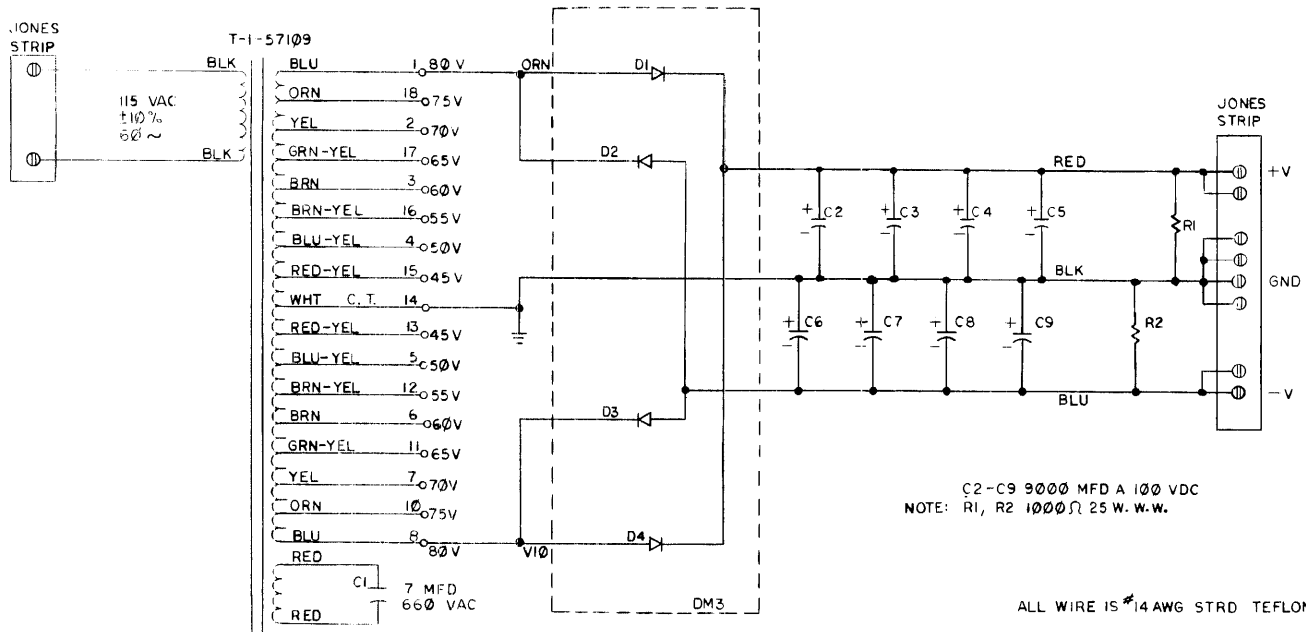

C2-C9 9000 MFD A 100 VDC
NOTE: R1, R2 1000 Ω 25 W. W. W.

ALL WIRE IS #14 AWG STRD TEFLON

OUTPUT VOLTAGE	TAPS	TOTAL OUTPUT CURRENT
80 V	1-14-8	5 AMPS
75 V	18-14-10	5.33 A
70 V	2-14-7	5.71 A
65 V	17-14-11	6.15 A
60 V	3-14-6	6.66 A
55 V	16-14-12	7.27 A
50 V	4-14-5	8.0 A
45 V	15-14-13	8.8 A

6-28

REV.	CHG.	NO.	REV.

DEC FORM NO. DRC 102

DRN: *Denny* DATE: 4/11/67
 CHD: *Pillars* DATE: 7/29/69
 ESD: *Smith* DATE: 8/15/69
 PRP: *Smith* DATE: 8/20/69

TRANSISTOR & DIODE CONVERSION CHART			
DEC	EIA	DEC	EIA

digital EQUIPMENT CORPORATION MAYNARD, MASSACHUSETTS	TITLE 793 POWER SUPPLY		
	SIZE C	CODE CS	NUMBER 793-0-1
PRINTED CIRCUIT REV.		REV.	

REV. 793-0-1

THIS SCHEMATIC IS FURNISHED ONLY FOR TEST AND MAINTENANCE PURPOSES. THE CIRCUITS ARE PROPRIETARY IN NATURE AND SHOULD BE TREATED ACCORDINGLY. COPYRIGHT BY DIGITAL EQUIPMENT CORPORATION

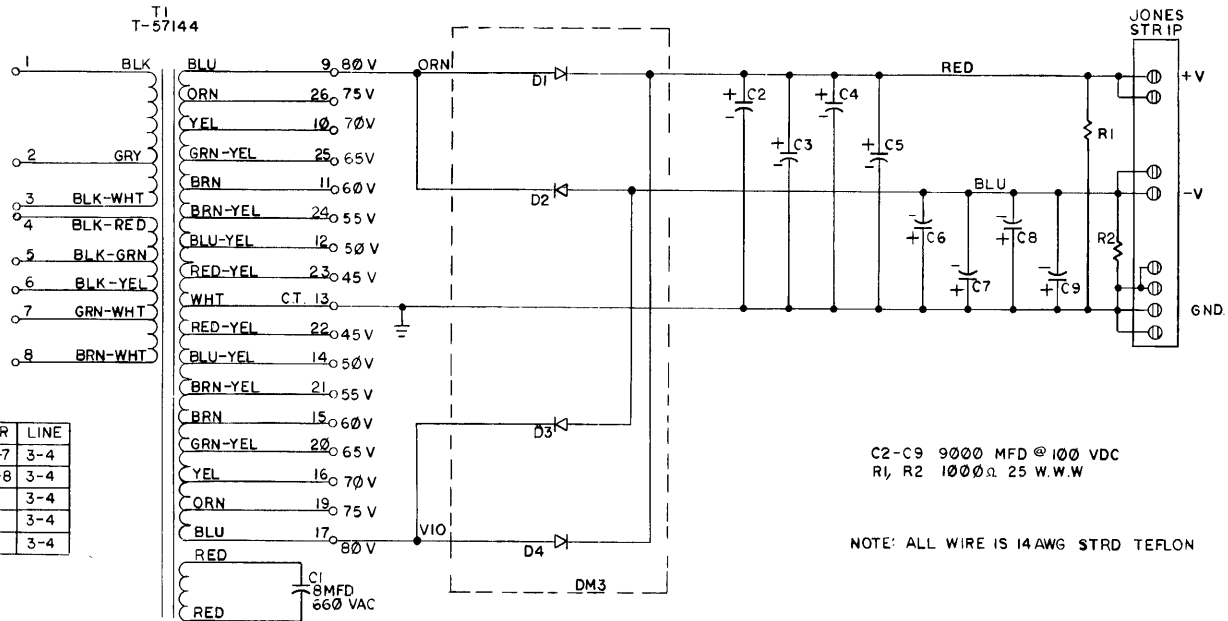

INPUT	JUMPER	LINE
112,5	2-4	3-7
123,5	1-4	3-8
195	1-5	3-4
220	1-6	3-4
235	2-8	3-4

C2-C9 9000 MFD @ 100 VDC
R1, R2 1000Ω 25 W.W.W

NOTE: ALL WIRE IS 14AWG STRD TEFLON

OUTPUT VOLTAGE	TAPS	TOTAL OUTPUT CURRENT
80 V	9-13-17	5 AMPS
75 V	26-13-19	5.33 A
70 V	10-13-16	5.71 A
65 V	25-13-20	6.15 A
60 V	11-13-15	6.66 A
55 V	24-13-21	7.27 A
50 V	12-13-14	8.0 A
45 V	23-13-22	8.8 A

6-29

REVISIONS CHECK NO. REV.	DRN. <i>[Signature]</i> DATE <i>1/14/69</i>	TRANSISTOR & DIODE CONVERSION CHART					TITLE	50 CYCLE		
	CHKD. <i>[Signature]</i> DATE <i>1/14/69</i>	DEC	EIA	DEC	EIA		793A POWER SUPPLY	SIZE	CODE	NUMBER
	EMP. <i>[Signature]</i> DATE <i>1/14/69</i>					EQUIPMENT CORPORATION	C	CS	793-A-1	
	PRD. <i>[Signature]</i> DATE <i>1/14/69</i>					MAYNARD, MASSACHUSETTS				
						PRINTED CIRCUIT REV.				

REV. 1
NUMBER 793-A-1
SIZE CODE C CS

**Digital Equipment Corporation
Maynard, Massachusetts**

