

EK-KDA5Q-UG-001

KDA50-Q
USER GUIDE
(SEMI-FINAL REVIEW)

Digital Equipment Corporation
Colorado Springs, Colorado

1st Edition, November 1984

Copyright c 1984
by Digital Equipment Corporation
All Rights Reserved

The material in this manual is for informational purposes and is subject to change without notice. Digital Equipment Corporation assumes no responsibility for any errors which may appear in this manual. Digital Equipment Corporation makes no representation that the interconnection of its mass storage products with products of other manufacturers will not infringe on existing or future patent rights. Nor do the descriptions contained herein imply the granting of licenses to make, use, or sell equipment constructed or configured in accordance herewith. ~~#~~ The Digital Storage Architecture (DSA) and Standard Disk Interconnect (SDI) mass storage products manufactured by Digital Equipment Corporation are designed to work with host computers and DSA and SDI products designed by Digital Equipment Corporation. Digital Equipment Corporation assumes no responsibility or liability if the host computers, controllers, mass storage servers, tape, or disk products of another manufacturer are used with these DSA and SDI products.

Printed in U.S.A.

This equipment generates, uses, and may emit radio frequency energy. This equipment has been type tested and found to comply with the limits for a Class A computing device pursuant to Subpart J of Part 15 of FCC Rules, which are designed to provide reasonable protection against such radio frequency interference when operated in a commercial environment. Operation of this equipment in a residential area may cause interference in which case the user at his own expense may be required to take measures to correct the interference.

The following are trademarks of Digital Equipment Corporation,
Maynard, Massachusetts:

DEC	DECnet	OMNIBUS
DECUS	DECsystem-10	OS/8
DIGITAL	DECSYSTEM-20	PDT
Digital Logo	DECwriter	KDA50-Q
PDP	DIBOL	RSTS
UNIBUS	Edusystem	RSX
VAX	MASSBUS	VMS
RA81	RA60	VT
HSC50	RA80	UDA50
		IAS

CONTENTS

CHAPTER 1	INTRODUCTION	
1.1	DISK CONTROLLER	1-1
1.2	DIGITAL STORAGE ARCHITECTURE (DSA)	1-2
1.3	MASS STORAGE CONTROL PROTOCOL	1-2
1.4	KDA50-Q MODULES	1-3
1.4.1	The SDI Module	1-3
1.4.2	The Processor Module	1-3
1.5	KDA50-Q FUNCTIONAL MICROCODE	1-4
1.5.1	QBUS Control Stream	1-4
1.5.2	Drive Control Stream	1-5
1.6	KDA50-Q SPECIFICATIONS	1-6
1.7	DIGITAL CUSTOMER SERVICE CONTRACT OPTIONS	1-7
1.7.1	Hardware Services	1-7
1.7.2	Software Services	1-8
1.8	RELATED DOCUMENTATION	1-9
CHAPTER 2	INSTALLATION	
2.1	INTRODUCTION	2-1
2.2	MODULE PREPARATION AND INSTALLATION	2-4
2.2.1	I/O Page Address Switches And Jumper	2-4
2.2.2	QBUS Tuning	2-8
2.2.2.1	QBUS Device Positions	2-8
2.2.2.2	KDA50-Q Burst Rate Parameter	2-10
2.2.3	M7164 Intermodule Cable Installation	2-10
2.2.4	M7164 Module Installation	2-11
2.2.5	M7165 SDI Cable Installation And Initial M7165 Insertion	2-11
2.2.6	M7165 Intermodule Cable Installation	2-13
2.2.7	Final M7165 Installation	2-13
2.3	STANDARD INSTALLATION PACKAGE	2-13
2.3.1	I/O Bulkhead Installation	2-13
2.3.2	Internal SDI Cables	2-14
2.3.3	External SDI Cables	2-15
2.4	ALTERNATE INSTALLATION PACKAGE	2-16
2.4.1	Mounting The Alternate Bulkhead Assembly	2-16
2.4.2	Internal SDI Cable Installation	2-19
2.4.3	External SDI Cable Installation	2-19
2.5	FIELD ACCEPTANCE TEST PROCEDURE	2-20
2.5.1	Drive-Resident Diagnostics	2-24
2.5.2	Subsystem Diagnostics	2-24
2.5.2.1	PDP-11 Subsystem Diagnostics	2-25
2.5.2.2	VAX Subsystem Diagnostics	2-27
2.6	SYSTEM AND SOFTWARE CONSIDERATIONS	2-27
2.6.1	System Clock Or Timer	2-27

2.6.2	Error Logs	2-27
2.6.3	Drive Numbering	2-28
2.6.4	System Performance And Operation	2-28

CHAPTER 3 KDA50-Q PROGRAMMER INFORMATION

3.1	KDA50-Q-SPECIFIC PROGRAMMING INFORMATION	3-1
-----	--	-----

FIGURES

1-1	KDA50-Q Disk Subsystem Configuration	1-1
2-1	KDA50-Q Illustrated Parts	2-2
2-2	M7164 QBUS Address switch and Jumper Locations	2-6
2-3	KDA50-Q Switch Setting for Address 172150 (F468 Hex)	2-6
2-4	Address Selector Switch Operation	2-7
2-5	M7165 Jumper Locations	2-7
2-6	KDA50-Q Intermodule Flat Ribbon Cables	2-11
2-7	M7165 SDI Cable Assembly Installation	2-12
2-8	Ball 2x3 Adapter Plate Installation	2-14
2-9	Bulkhead to I/O Panel Attachment	2-14
2-10	Internal SDI Cable Installation	2-15
2-11	Grounding Internal SDI Cable(s) [TBD]	2-15
2-12	External SDI Cable Installation [TBD]	2-16
2-13	Alternate Bulkhead Assembly	2-18
2-14	Diagnostic LED Locations on KDA50-Q Modules	2-21

TABLES

1-1	KDA50-Q Specifications	1-6
2-1	KDA50-Q Assemblies	2-1
2-2	LED Error and Symptom Codes	2-21

NOTE

Information that is currently unavailable is designated by: [TBD].

1.1 DISK CONTROLLER

The KDA50-Q is an intelligent controller which interfaces up to four, 16-bit, RA series disk drives to any CPU that operates on a QBUS. Two quad-height modules, the Standard Disk Interconnect (SDI) module and the Processor module, make up the KDA50-Q.

The KDA50-Q uses a radial bus configuration instead of the conventional daisy-chain (serial) method. Radial configuration means that there is a separate I/O cable going to each disk drive. Figure 1-1 shows the KDA50-Q subsystem configuration.

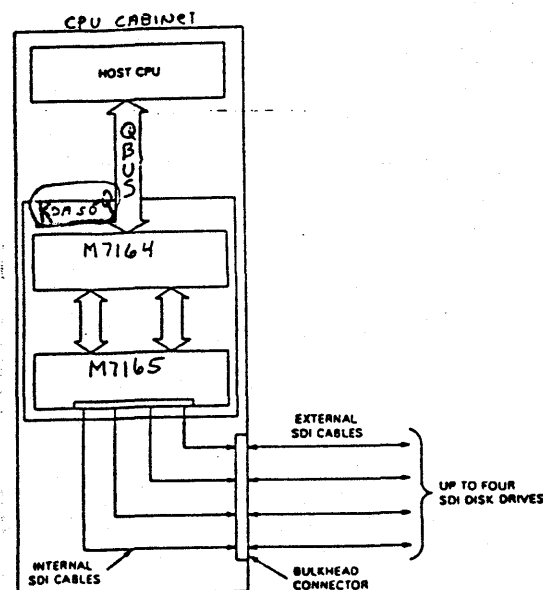

Figure 1-1: KDA50-Q Disk Subsystem Configuration

INTRODUCTION

1.2 DIGITAL STORAGE ARCHITECTURE (DSA)

The KDA50-Q belongs to the family of DSA products which implement the Standard Disk Interconnect (SDI). DSA defines the operating rules of mass storage subsystems and how they interface with the host computer. Some of the characteristics of DSA are listed below.

- o I/O management has been moved from the host to the controller.
- o The host views the disk subsystem as one contiguous string of sectors known as logical blocks. A logical block contains 512 bytes of information.
- o The host is not concerned with disk geometry such as cylinder, track, sector, etc.
- o Host and subsystem exchange messages use the Mass Storage Control Protocol.

1.3 MASS STORAGE CONTROL PROTOCOL

The KDA50-Q Disk Controller is a Mass Storage Control Protocol (MSCP) device. MSCP is a communication protocol used with intelligent mass storage controllers. MSCP hides device-dependent requirements, such as disk geometry and error recovery strategies, from the host. It thus enables several different device drivers to be replaced by one class driver.

To request an I/O operation, the host constructs an MSCP message and sends it to the controller. The MSCP message contains the drive address, the function to be performed, the starting logical block number (sector), and the amount of data requested. The message does not contain drive geometry information because MSCP hides device dependant requirements. When the subsystem receives the request, it performs all drive management and data movement, as well as any necessary recovery, independently. Upon completion, the subsystem sends the host an MSCP response message giving status information. This flow differs from conventional subsystems, in which host computer resources would be used to control the drive. One recovery technique is called revectoring, when the KDA50-Q accesses a replacement sector instead of the original sector previously found to be in error. A sector is marked as bad, and replaced via a cooperative process between the host software and the KDA50-Q.

INTRODUCTION

1.4 KDA50-Q MODULES

The following paragraphs describe the hardware on both the SDI module and the processor module.

1.4.1 The SDI Module

The SDI module (M7165) is the the communication interface between the KDA50-Q processor module and the disk drives. Some of the circuitry and functions of the SDI module are listed below.

- o Contains a 32K byte high speed buffer that is used during data transfers. The buffer allows controller-to-drive tranfers to occur at a higher rate than controller-to-host transfers which improves performance by minimizing missed disk revolutions due to a buffer full condition.
- o Converts the KDA50-Q buffer format (parallel) to SDI format (serial) and vice-versa.
- o Generates the real-time Error Correction Code (ECC). This code has a correction capability of up to 8 10-bit error bursts per block (sector).
- o Implements the real-time and electrical interface to the SDI, including error detection on the SDI, and RAM.

1.4.2 The Processor Module

The processor module (M7164) is the control portion of the KDA50-Q. Some of the circuitry and functions of the processor module are listed below.

- o Performs all KDA50-Q interaction with the QBUS via two registers; the Initializing and polling (IP) register and the Status/address (SA) register. A switch pack is used to set the I/O page register address.
- o Reports microcode detected errors through four LEDs on the processor module and four LEDs on the SDI module. The error code reported indicates the module to replace.
- o Also located on the processor module is a dual microprocessor. It is made up of two 12-bit microprogram sequencers which share a common 16-bit ALU.

INTRODUCTION

The combination of the sequencers and the shared ALU creates a dual microprocessor capable of executing two independent, interleaved microprograms (from Read Only Memory) at the same time. One of the sequencers controls the KDA50-Q to host interaction and the other controls the KDA50-Q to disk drive interaction. For greater efficiency, one sequencer fetches an instruction while the other executes an instruction.

1.5 KDA50-Q FUNCTIONAL MICROCODE

The functional microcode can be divided into two functional flows or streams. The QBUS control stream which manages the controller to host interface and the drive control stream which manages the controller to disk drive interface.

1.5.1 QBUS Control Stream

Some of the functions that the QBUS Control Stream performs are listed below.

- o Tracks to the appropriate handling routine in the microcode when the host has a command to send to the KDA50-Q or the KDA50-Q has a response to send to the host.
- o Exchanges information packets with the host in memory.
- o Validates each packet from the host.
- o Constructs the KDA50-Q response packets for transmission to the host.
- o Analyzes the drive packets and performs the functions listed below.
 - o Decodes the logical block number (LBN) to cylinder, group, track, and sector information.
 - o Optimizes seek selection from the outstanding commands.
 - o Allocates data buffer space.

INTRODUCTION

- o Computes and stores parameters for each sector transfer.
- o Performs packet error detection.
- o Performs memory mapping for mapped requests.
- o Transfers data between the host and internal memory (including automatic support for block mode memories).

- o Performs ECC error correction.
- o Polls the command queue at the completion of each command.
- o Performs initialization.
- o Initiates Drive Control Stream packet executions.

1.5.2 Drive Control Stream

Some of the functions that the Drive Control Stream performs are listed below.

- o Monitors ATTENTION from the drives. When drive attention has been detected, the Drive Control Stream gets the drive status, compares it with the previous status, and takes the appropriate action.
- o Constructs and sends packets to the disk drives. The packets may be the result of a host request (read, write, replace, etc.) or in response to a drive attention condition.
- o Receives and validates packets from the drives.
- o Monitors the drive status flags from the QBUS Control Stream. The drive status flags are used for communication between the QBUS control stream and the Drive Control Stream.
- o Performs tasks as required by the drive status flags. Some of these tasks are listed below.

INTRODUCTION

- o Initiates read, write, seek, and head select packets to the drive.
- o Reads and verifies the block (sector) header.
- o Performs data transfers between internal RAM and the disk drive.
- o Updates drive status and buffer-use flags.
- o Performs data error analysis and recovery.
- o Performs bad block revectoring.

1.6 KDA50-Q SPECIFICATIONS

The KDA50-Q Disk Controller Specifications are described in Table 1-1.

Table 1-1: KDA50-Q Specifications

Characteristics	Specifications
Physical components	KDA50-Q processor module (M7164) KDA50-Q SDI module (M7165) 50-pin flat cable assembly 40-pin flat cable assembly SDI cable assembly I/O bulkhead assemblies
Power consumption	67.9 Watts nominal
Heat dissipation	Approximately 238.6 Btu/hour
Electrical voltage and current requirements	13.5 Amps at +5 Volts, 30 milliAmps at +12 Volts
QBUS Loading	3.0 AC / 0.5 DC standard loads (total)
Operating temperature range	10° C to 40° C (50° F to 104° F) with a temperature gradient of 20° C/hour (36° F/hour)

INTRODUCTION

Table 1-1 (cont.)

Characteristics	Specifications
Operating relative humidity range	10% to 90% with a wet bulb temperature of 28° C (82° F) and a minimum dew point of 2° C (36° F)
Operating altitude range	Sea level to 2400 meters (8000 ft). Derate the maximum allowable operating temperature by 1.8° C/1000 meters (1° F/1000 feet) for operation above sea level
Mounting restrictions	Mounts in two quad-height QBUS SPC slots in the following mounting boxes: BALL-S or -N BA23 (rackmounted) with H3490
Bulkhead requirements	Two 2x3" cutouts for BALL-S or -N, Two 3x2" standard cutouts for H3490

1.7 DIGITAL CUSTOMER SERVICE CONTRACT OPTIONS

You can upgrade your CPU system smoothly and efficiently and maintain optimum performance of your new system by taking advantage of one of the service options listed below.

1.7.1 Hardware Services

Add-on and upgrade services get you started. We strongly recommend that your new CPU upgrade be installed by qualified DIGITAL field service technicians. Installation includes:

1. Pre-installation evaluation to ensure a suitable site environment including power, temperature, and humidity.
2. Physical connection of equipment and verification of full system functionality.

INTRODUCTION

Maintenance services keep you going. Once your upgrade has been installed by DIGITAL field service, the entire upgraded system will be eligible for coverage by one of the following DIGITAL comprehensive service contracts.

1. DECservice - A comprehensive on-site service provides committed response times, continuous effort until the problem is solved, a program of preventive maintenance, installation of the latest engineering changes, and automatic escalation for complex problems.
2. Basic Service - An economical full service coverage provides priority status, second only to DECservice calls, and you get the preventive maintenance on-site services listed above.

For less comprehensive but equally reliable service you can choose Per Call Service, Carry-In Service or DECmailer Service.

1.7.2 Software Services

If your need is to analyze your current system, develop or implement software, or upgrade your existing system, DIGITAL offers a service to meet your needs. The following services will be of particular interest to you as you plan to add on or upgrade.

1. Computer Performance Service - Helps you develop growth plans by identifying add-on or upgrade options before problems begin.
2. System Start-up Service Packages - Provides fixed-cost training for your staff and one year of support services.
3. Consulting Services - Provides software programming or project manager expertise on a resident, per-call, or fixed-price basis. Your choice.

Whichever DIGITAL service option you select, you will receive high quality, reliable service from one of the largest service organizations in the industry. For more information, call your

INTRODUCTION

local DIGITAL field service office.

1.8 RELATED DOCUMENTATION

DIGITAL customers may order the following KDA50-Q related manuals.

- o KDA50-Q SERVICE MANUAL (EK-KDA5Q-SV)
- o KDA50-Q FIELD MAINTENANCE PRINT SET (MP-01423)

Employees:

The User Guide and Service Manual may be ordered directly from Publication and Circulation Services, 10 Forbes Road, Northboro, Massachusetts 01532 (RCS Code: NR12, Mail Code: NR03/W3).

The Field Maintenance Print Set can be ordered directly from the Software Distribution Center, 444 Whitney Street, Northboro, Massachusetts 01532 (RCS Code: MSDC, Mail Code: NRO2-1/J6).

Non-Employees:

The above documents can be ordered directly from Digital Equipment Corporation, P.O. Box CS2008, Nashua, New Hampshire 03061, or by calling toll free: 800-258-1710.

Outside the United States, consult local DIGITAL offices.

CHAPTER 2
INSTALLATION

2.1 INTRODUCTION

The KDA50-Q is a two board disk controller that can be installed in a variety of CPU packages. Although these packages are different, the KDA50-Q installation procedure for them is similar. The differences will be called out where needed. Table 2-1 lists these packages and the KDA50-Q assembly to be used with them.

Table 2-1: KDA50-Q Assemblies

CPU Package	KDA50-Q Assembly
-----	-----
BAll -S or -N (5 1/4" BOX)* or BA23 with H3490**	KDA50-QA
Alternate Installation Package	KDA50-QB

* The BAll box uses an I/O panel which has cutouts intended for MASSBUS cable use. These cutouts must be adapted to 2x3 cutout size as shown in Figure 2-7.

** If needed, please also order BA23 Expansion Rackmount Package, Part Number [TBD], when installing this assembly. This package permits the optional addition of a second rackmounted BA23 with a QBUS expansion kit. This package includes the BA23 expansion cabinet, the BA23 rackmount kit, and the H3490 expansion I/O bulkhead.

The installation procedure for the KDA50-Q Disk Controller requires the insertion of two quad-height modules into a QBUS backplane. These two modules are inserted in adjacent slots so the intermodule cables can be connected between them. An I/O bulkhead must be installed in the cutout provided at the rear of the CPU cabinet unless the alternate installation procedure,

INSTALLATION

described in section 2.4, is used. An internal SDI cable connects the modules to the I/O bulkhead. The disk drives are then connected to the I/O bulkhead. Figure 2-1 shows an illustrated parts breakdown of the KDA50-Q assembly.

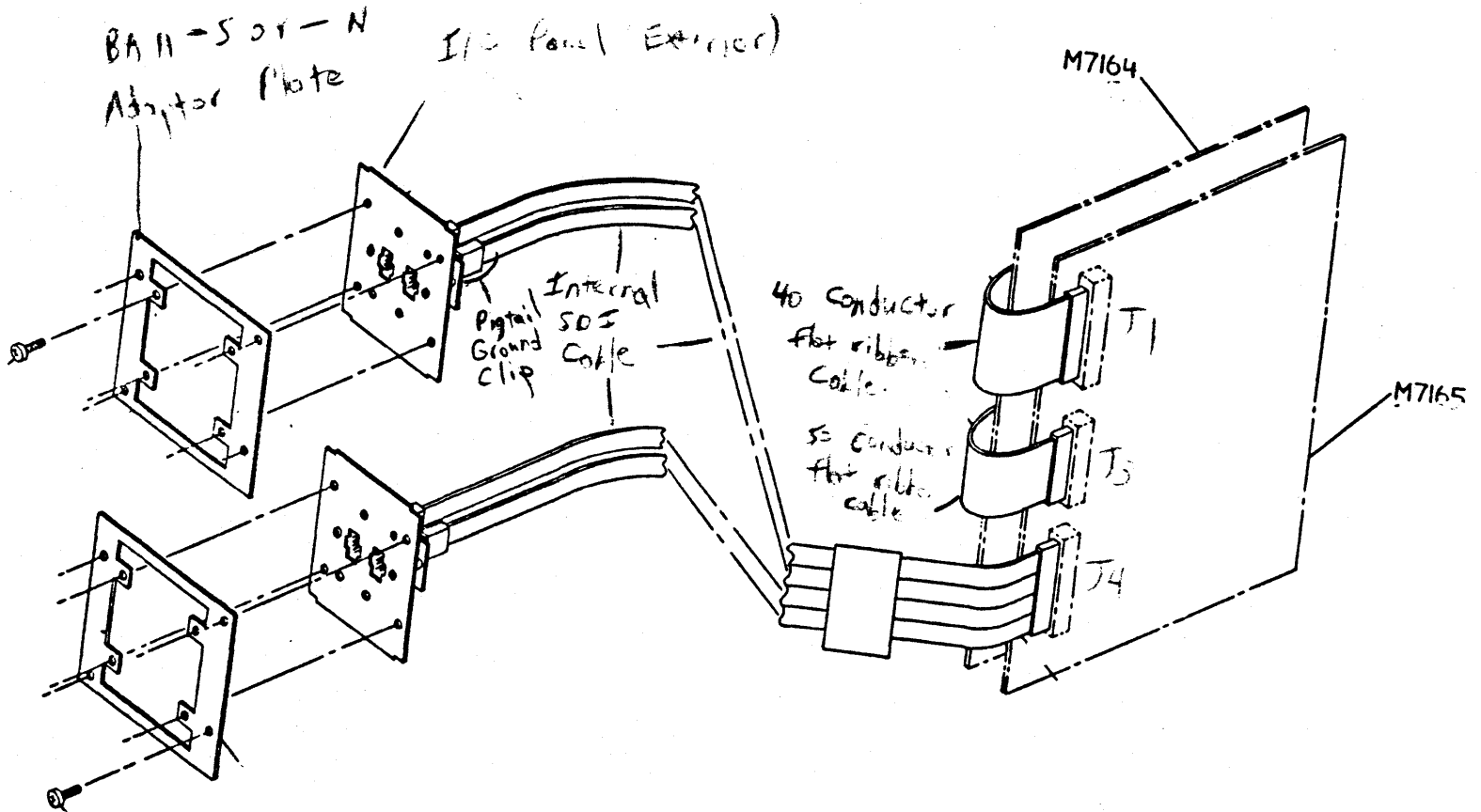

Figure 2-1: KDA50-Q Illustrated Parts

INSTALLATION

The KDA50-Q modules may be installed horizontally or vertically depending on the CPU package used. If the CPU package requires the horizontal insertion of modules, the following checklist may still be used by considering module M7164 the top module. The following installation checklist indicates where each procedure is described.

- o Check the DC power needs, AC and DC QBUS loading, and panel requirements for your system (Table 1-1) _____
- o Check the I/O page address switches and jumper (2.2.1) _____
- o Connect the 40-conductor and the 50-conductor intermodule cables to module M7164 (J2) and (J4) respectively (2.2.3) _____
- o Insert module M7164 into the first (top or left) of two vacant backplane slots and engage the handle retainer latches. Leave the 50 conductor cable on top of the handle retainer latch. (2.2.4) _____
- o Insert and clamp the internal SDI cable to module M7165 (J4). Slide M7165 one-half the way into second backplane slot (2.2.5) _____
- o Connect both the 40-conductor and the 50-conductor intermodule cables to module M7165 (J3 and J1) (2.2.6) _____
- o Press M7165 into the backplane, engaging the handle retainer latches. (2.2.7) _____
- o If the standard installation package is used: install the I/O bulkhead connector assembly, route the internal SDI cable ends to the bulkhead location, and connect the external SDI cables (from DSA disks) to the bulkhead assembly (2.3) _____
- o If the alternate installation package is used: mount the alternate bulkhead assembly, connect the internal SDI cable ends to the bulkhead assembly, and connect the external SDI cables (2.4) _____
- o Perform the field acceptance test procedure (2.5) _____

INSTALLATION

NOTE

The position of the KDA50-Q modules can be reversed. Ensure that the top or left module initially installed has the 40-conductor and 50-conductor flat ribbon cables attached. Also ensure that the 50-conductor flat ribbon cable connected to the second module is not crimped by the module handle retainer latches.

2.2 MODULE PREPARATION AND INSTALLATION

The following paragraphs describe how to install the KDA50-Q modules, I/O bulkhead, and cables.

2.2.1 I/O Page Address Switches And Jumper

The KDA50-Q Disk Controller contains two registers that are visible in the I/O page. They are the initializing and polling (IP) register and the status and address (SA) register. The IP register is assigned the default octal Q-BUS address of 172150 (F468 Hex). The SA register address is the IP address plus 2.

NOTE

QBUS address bits 13 and above in the IP register are unadjustable and are automatically assigned a value of 1.

The QBUS address selector switches and a jumper (W1) are used to set the QBUS address for the IP register. The location of these switches and the jumper on KDA50-Q module (M7164) is shown in Figure 2-2. Set the QBUS address switches and jumper to the positions shown in Figure 2-3 to select octal QBUS address 172150 (F468 Hex). This address is the default value shipped with the KDA50-Q (jumper W1 is installed). Alternate octal addresses for the IP register are: 160334 (E0DC Hex) and 160340 (E0E0 Hex). (Jumper W1 should be removed). If you are unsure of the switch operation refer to Figure 2-4.

NOTE

W2 and W3 must be removed for Q22/CD backplanes and left installed for Q22/Q22 backplanes on both

INSTALLATION

modules M7164 (refer to Figure 2-2) and M7165 (refer to Figure 2-5).

INSTALLATION

Please
Delete

$W1\ In = 1$
 $W1\ out = \emptyset$

QBUS ADDRESS BITS	17	16	15	14	13	12	11	10	9	8	7	6	5	4	3	2	1	0
OCTAL CODE	7			7			2			1			5			0		
BINARY CODE	1	1	1	1	1	1	0	1	0	0	0	1	1	0	1	0	0	0
KDA50 Switch Setting	1	1	1	1	1	1	IN	S1 OFF	S2 ON	S3 OFF	S4 OFF	S5 OFF	S6 ON	S7 ON	S8 OFF	S9 ON	S10 OFF	
	ALWAYS ONES												ALWAYS ZEROS					

Figure 2-2: M7164 QBUS Address switch and Jumper Locations

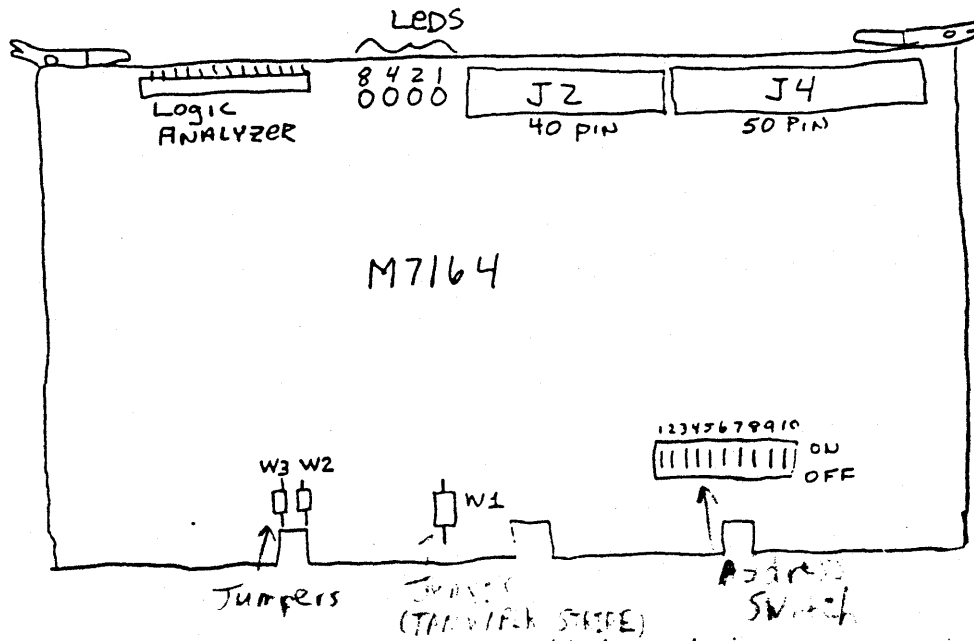

Figure 2-3: KDA50-Q Switch Setting for Address 172150 (F468 Hex)

INSTALLATION

rocker:

modified rocker:

slider:

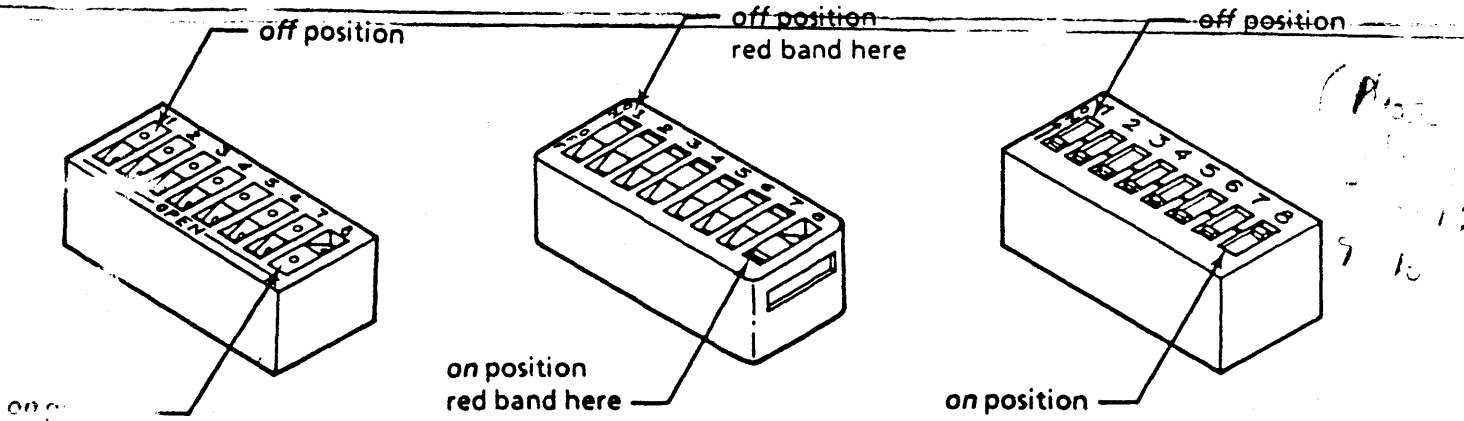

Note: In each picture, switches 1 through 8 are shown in the off position, and switch 9 is shown in the on position.

Figure 2-4: Address Selector Switch Operation

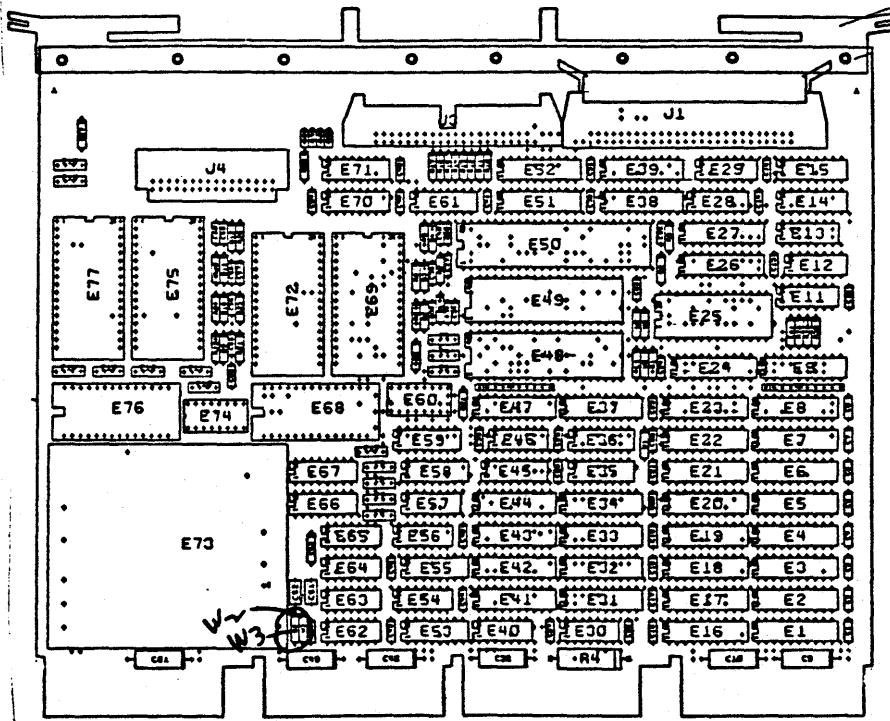

← Figure 2-5:

M 7165
Jumper Locations

NOTE

The QBUS address switches and jumpers should be set for a floating address when a second DSA controller is installed on a system. To determine a floating address, check the system

INSTALLATION

configuration and QBUS addresses of all devices already installed. Common floating octal addresses are 160340 (E0E0 Hex) and 160330 (E0D8 Hex).

In past disk products, a vector address was also physically selectable. This is not true with the KDA50-Q Disk Controller. A typical vector address of 154 (octal) will be supplied to the KDA50-Q by the software.

2.2.2 QBUS Tuning

Sometimes a QBUS system will experience data late or reduced performance conditions that can be remedied by tuning the QBUS. This process involves changing the relative positions of the Direct Memory Access (DMA) devices on the bus, or making use of other product features. The device electrically nearest the host processor has the highest priority; the device farthest away from the host processor has the lowest priority.

2.2.2.1 QBUS Device Positions -

Non-DMA interfaces in a QBUS should usually be placed electrically nearest to the host processor since they do not significantly affect the performance level of DMA devices.

The proper positioning of DMA devices on the QBUS involves several considerations.

1. The instantaneous bandwidth requirements of the device or interface.

Faster raw bandwidth devices typically require a higher priority, though this higher priority requirement can be offset by buffering in the interface which reduces the instantaneous bandwidth requirements from the interface. Interfaces with little buffering may require that the instantaneous bandwidth match or exceed the effective bandwidth for the device.

While the KDA50-Q interfaces to some very fast disk devices, it is well buffered internally (which results in a relatively low instantaneous bandwidth requirement) and operates dependably at the very end of the QBUS (lowest priority). The KDA50-Q will wait very long periods of time to gain access to the bus, and proceed

INSTALLATION

from this waiting period without error.

2. The amount of time the interface occupies the QBUS during each bus access.

Devices that hold the QBUS for longer periods of time should usually be placed at a lower priority, to reduce the time that a higher priority device must wait for gaining access to the QBUS.

The KDA50-Q occupies the bus according to the setting of the Burst rate parameter given to it by the operating system. The default value of four long-words (8 word transfers) results in occupying the bus for a value which is carefully chosen to provide a compromise between a small bus occupancy time and a higher level of performance resulting from transferring more words in every bus acquisition. The default value encourages placing the KDA50-Q towards the end of the QBUS, but ahead of devices with longer bus occupancy times.

3. The amount of time the interface waits before re-requesting the QBUS again.

Since all DMA devices must wait until the QBUS is available, a higher priority device which requests access rapidly may preclude a lower priority device from accessing the QBUS for significant periods of time.

The KDA50-Q leaves a reasonable amount of time before requesting the bus for a successive transfer, and this permits lower priority DMA devices to gain access to the bus. In the interest of performance, this time is not so large that a great many lower priority devices could be satisfied between two KDA50-Q requests. This KDA50-Q successive transfer time allowance encourages placing the KDA50-Q near but not at the end of the bus.

4. The average bandwidth requirements of the device in usage.

A more frequently used device in the configuration should be given a higher priority. In the QBUS, there is some intrinsic delay in each bus cycle according to how many higher priority interfaces the bus grant must pass through before reaching the interface which wants to use the bus.

This consideration is highly application dependent, but it would be expected that the large storage devices connected to the KDA50-Q would be used frequently. This

INSTALLATION

would encourage placing the KDA50-Q further away from the end of the QBUS.

Overall, the recommendation is to place the KDA50-Q ahead of such devices as the RC25 and RQDX, and behind other DMA devices. However, do not worry if physical configuration details force you to place the KDA50-Q at the very end of the bus (assuming that bus grants are passed to the KDA50-Q).

2.2.2.2 KDA50-Q Burst Rate Parameter -

The KDA50-Q burst rate parameter is a value settable by host software that indicates how many long-words (32 bits) the KDA50-Q will attempt to transfer when it accesses the QBUS. The default for this parameter is four, but can range from one to eight.

The overall system efficiency increases by increasing the KDA50-Q burst parameter to a number greater than one. However, data late conditions (on other devices) may become increasingly likely as the parameter is increased.

The default value of four on other devices is chosen to suit a large majority of system configurations.

2.2.3 M7164 Intermodule Cable Installation

The KDA50-Q modules must be interconnected by two 4 inch long flat ribbon cables as shown in Figure 2-6. The outer cable is a 50-conductor flat ribbon cable that connects M7164 (J4) to M7165 (J1). The inner cable is a 40-conductor flat ribbon cable that connects M7164 (J2) to M7165 (J3). Install the two cables on module M7164 first.

INSTALLATION

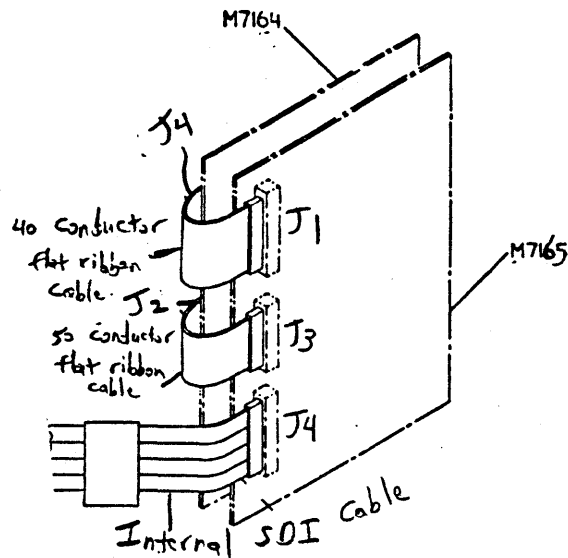

Figure 2-6: KDA50-Q Intermodule Flat Ribbon Cables

2.2.4 M7164 Module Installation

At this point, module M7164 should have two intermodule cables attached to it and the I/O page address switches and jumper should be properly set.

Ensure that previously inserted modules form a continuous grouping in the backplane.

Insert M7164 into the first of two vacant backplane slots. This slot should be the top or left backplane slot of the pair.

Press M7164 into the backplane and engage the handle retainer latches. Ensure the 50-conductor flat ribbon cable is on top of the handle retainer latch.

2.2.5 M7165 SDI Cable Installation And Initial M7165 Insertion

Insert plug P4 of the internal SDI cable assembly into connector J4 on KDA50-Q module M7165 as shown in Figure 2-7. Slide the cable retainer over connector J4 until the connector protrudes through the plastic cutout. The cable retainer should lock the SDI cable in place.

INSTALLATION

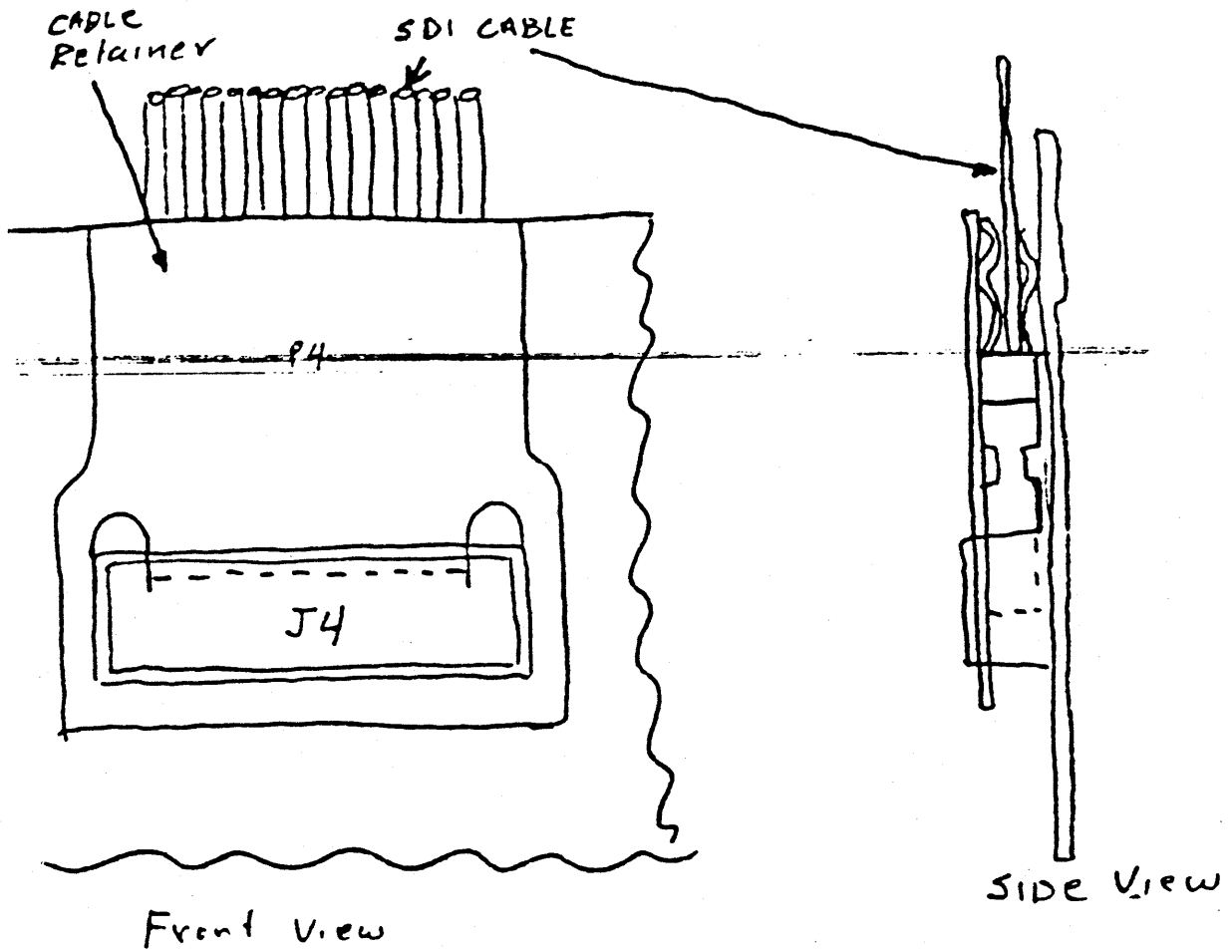

Figure 2-7: M7165 SDI Cable Assembly Installation

Slide M7165 approximately one-half the way into the backplane slot.

INSTALLATION

2.2.6 M7165 Intermodule Cable Installation

Install the 40-conductor flat ribbon cable on module M7165 (J3) and the 50-conductor flat ribbon cable on M7165 (J1) as shown in Figure 2-6.

2.2.7 Final M7165 Installation

Press M7165 into the backplane and engage the handle retainer latches. Ensure the 50-conductor flat ribbon cable is on top of the handle retainer latch. Also ensure both modules are now secure and none of the cables are crimped by the latch handles.

2.3 STANDARD INSTALLATION PACKAGE

Use the following procedures when installing the KDA50-QA assembly.

2.3.1 I/O Bulkhead Installation

An I/O bulkhead connector must be installed on the I/O panel at the rear of the CPU cabinet. The connectors are designed to fit in standard Digital Equipment Corporation 2x3 cutouts (used on most of the newer systems). If the system is installed in a BALL box, an adapter plate must be installed to convert the existing I/O panel cutout to standard 2x3 cutout size.

If an I/O panel is not available, refer to the Alternate SDI Cable Installation section 2.4.

Each bulkhead connector will accept two disk connections. Install both bulkheads and connect the internal SDI cables even if some parts will initially be unused. After the bulkheads have been installed, route the SDI cables to the bulkhead location.

Use the following procedure to install the I/O bulkhead connector assembly if an I/O panel is present.

- 1) If the BALL box is used, a 2x3 adapter plate must be used to change the existing I/O panel cutout to 2x3 cutout size. The adapter plate attaches on the inside of the I/O panel. Refer to Figure 2-8.

INSTALLATION

- Using four sem screws, attach the bulkhead assembly to the I/O panel. Make sure the EVEN marking is at the top or left as viewed from the outside of the I/O panel. Refer to Figure 2-9.

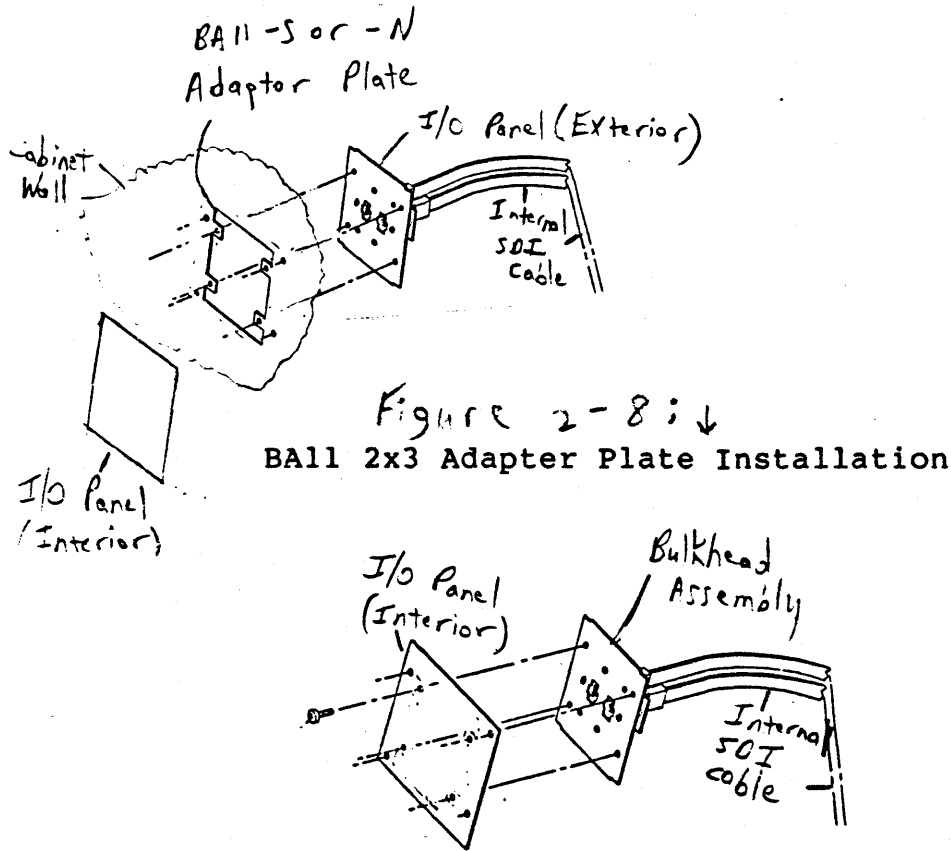

Figure 2-9: Bulkhead to I/O Panel Attachment

2.3.2 Internal SDI Cables

Install the internal SDI cables from the module to the bulkhead assembly using the following procedure. Refer to Figure 2-10.

Note how the cable ends and connectors are keyed for correct alignment. Attach the cable ends and the pigtail ground clips of the internal SDI cable assembly to the bulkhead assemblies. Port 0 (as viewed from the exterior) is located on the top or left of the bulkhead. Refer to Figure 2-11.

The internal SDI cable assemblies have been created so that it is not necessary to secure extra cable. If a cable retractor (used for service access) is present, the internal SDI cable should be attached.

INSTALLATION

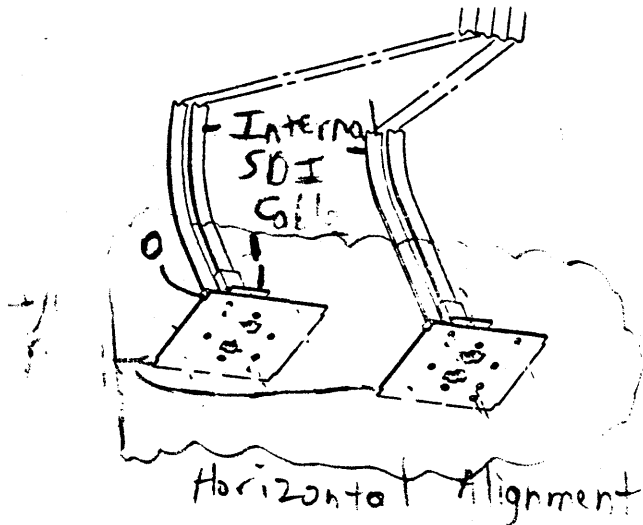

(Vertical Alignment Fig to be Supplied)

Figure 2-10: Internal SDI Cable Installation

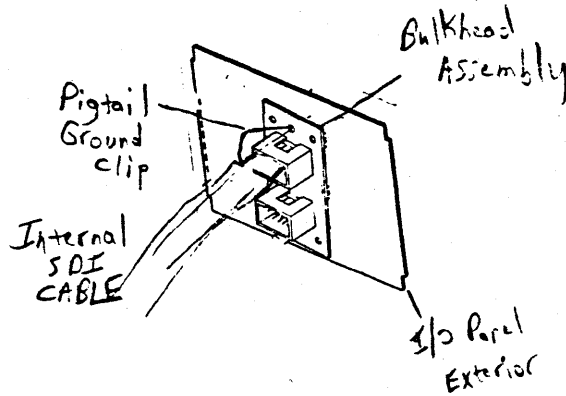

Figure 2-11: Grounding Internal SDI Cable(s)

2.3.3 External SDI Cables

Refer to Figure 2-12 while completing the following procedure.

- 1) Plug the external SDI cables into the I/O bulkhead(s).
- 2) Secure the cables using the screw connections.
- 3) If the external cables connected to the I/O panel have their natural bend horizontally, use the following securing procedure. Refer to Figure 2-12.
 - a) Run the cables horizontally to a vertical rail.

INSTALLATION

- b) Twist the cables and route them vertically down the rail.
 - c) Tie the cables to the vertical rail.
- 4) If the external cables have their natural bend vertically, secure the cables at the base of the cab.
 - 5) Any cables that go to drives that are in the same cab as the CPU should have any extra cable length secured so that it will not interfere with the normal operation and servicing of the drive.

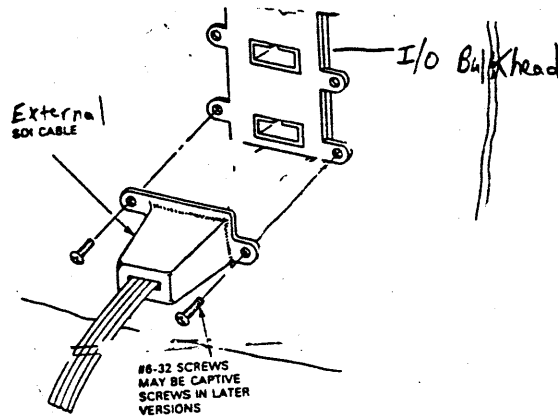

Figure 2-12: External SDI Cable Installation

2.4 ALTERNATE INSTALLATION PACKAGE

If an I/O panel is not present or if a very long internal SDI cable is required, the KDA50-Q alternate installation package should be used (Part Number KDA50-QB).

If 2x3 cutouts are available, use the installation instructions in the I/O Bulkhead Installation section above.

2.4.1 Mounting The Alternate Bulkhead Assembly

Use the following procedure only if it is impossible to mount the bulkhead to an I/O panel using a KDA50-QA. Refer to Figure 2-13.

1. Select a suitable location on either rear vertical cabinet rail where the alternate I/O bulkhead can be mounted without interfering with existing equipment.

INSTALLATION

Choose the lowest available location in the cabinet.

2. Push on the four u-nuts to align them with the holes in the vertical rail bracket.
3. Select the best angle and mount the bulkhead shield terminator onto the vertical rail bracket with two Phillips head sems (10-32 x 1/2 inch).
4. Mount the vertical rail bracket onto the vertical cabinet rail with the four Phillips head sems (10-32 x 1/2 inch).
5. Assemble the bulkhead assembly as shown in Figure 2-13.

INSTALLATION

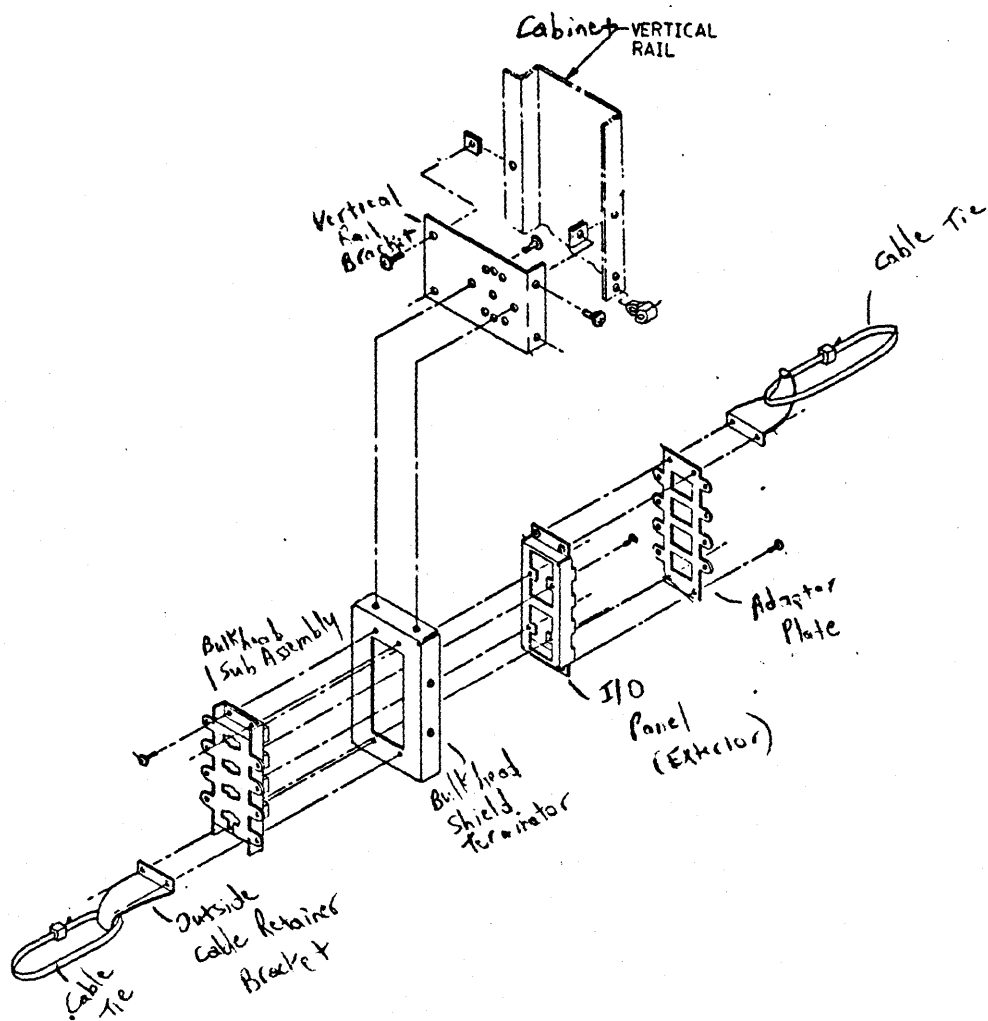

Figure 2-13: Alternate Bulkhead Assembly

INSTALLATION

2.4.2 Internal SDI Cable Installation

Install the internal SDI cables from the module to the bulkhead assembly using the following procedure. Refer to Figure 2-10. Note how the cable ends and connectors are keyed for correct alignment.

"",d","."

1. Connect the internal SDI cables to the bulkhead. Port 0 (as viewed from the exterior) is located on the top or left of the bulkhead.
2. Secure the internal SDI cables to the inside cable retainer bracket.
3. Secure any extra internal SDI cable(s) to the cabinet vertical rail.

2.4.3 External SDI Cable Installation

The external SDI cables must be grounded to the I/O bulkhead by mounting the shield terminators with screws. Use the following procedure to install the cables. Refer to Figure 2-12.

1. Plug the first SDI cable into the bottom or right I/O bulkhead connector and secure the cable using the screw connections.
2. Install an SDI cable for each disk drive, starting at I/O bulkhead connector 3 and moving to 0.

NOTE

One useful practice is to connect drive 0 to KDA50-Q port 0 and drive 1 to KDA50-Q port 1, etc. However, it actually does not matter which drive connects to which KDA50-Q port. The KDA50-Q treats each port equally and obtains the unit number for each drive from that drive.

3. Install the drive end of the SDI cables into the drive I/O bulkhead connectors as described in the disk drive user guide.

INSTALLATION

In most cases, the provisions already provided with the box should be used to secure the exterior SDI cables. If provisions have not been provided, the exterior cables should be secured to the backframe using cable tie(s).

2.5 FIELD ACCEPTANCE TEST PROCEDURE

The field acceptance and test procedure for the KDA50-Q Disk Subsystem has three parts.

1. Run the KDA50-Q Disk Controller resident diagnostic test.
2. Run the disk drive field acceptance test found in the disk drive user guide.
3. After each subsystem device has been tested separately, the KDA50-Q host-resident diagnostics are run to complete the third part of this procedure.

The KDA50-Q-resident diagnostics are initiated when power is applied to the KDA50-Q Disk Controller. The CPU should be halted during this test. The four LED indicators on each KDA50-Q module should display a cycling pattern in the LEDs. Refer to the third comment following Table 2-2. The cycling pattern in the LEDs signifies the completion of a successful KDA50-Q diagnostic test. Figure 2-14 shows the location of the four LEDs on each KDA50-Q module.

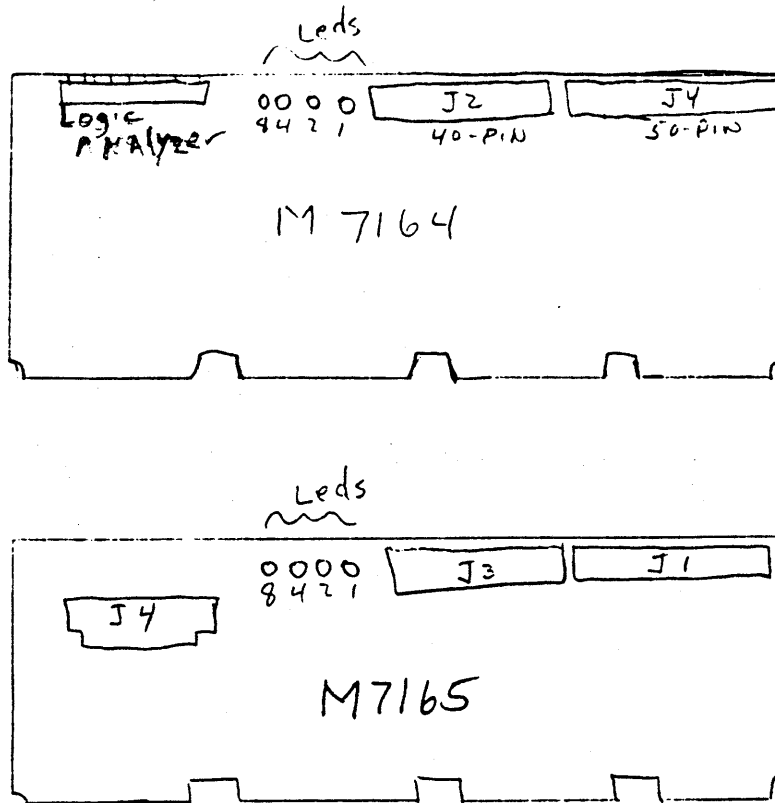

Figure 2-14: Diagnostic LED Locations on KDA50-Q Modules

If the KDA50-Q LEDs do not display the cycling pattern after power is applied, look up the LED code in Table 2-2 to locate the problem.

Table 2-2: LED Error and Symptom Codes

M7164 LEDs*	M7165 LEDs*	Error Symptoms	Most Likely Failure
8 4 2 1	8 4 2 1		
0 0 0 1	x x x x	Hex 1; undefined	Undefined
0 0 1 0	0 0 0 0	Hex 2; microcode stuck in init step 2	M7164 or software
0 0 1 1	0 0 0 0	Hex 3; microcode stuck in init step 3	**

INSTALLATION

Table 2-2 (cont.)

M7164 LEDs* 8 4 2 1	M7165 LEDs* 8 4 2 1	Error Symptoms	Most Likely Failure
0 1 0 0	0 0 0 0	Hex 4; microcode stuck in init step 4 or QBUS timeout error	M7164 or host inactive
0 1 0 I N K	0 0 0 0	Hex 4/5; test complete Normal display for operating KDA50-Q	No problem
0 1 1 0 x x x x	x x x x 0 1 1 0	Hex 6; undefined	Undefined
0 1 1 1 x x x x	x x x x 0 1 1 1	Hex 7; undefined	Undefined
1 0 0 0	0 0 0 0	Hex 8; wrap bit 14 set in SA register	M7164 or software
1 0 0 1 0 0 0 0	0 0 0 0 1 0 0 1	Hex 9; board one error	M7164
1 0 1 0 1 0 1 0	0 0 0 0 1 0 1 0	Hex A; board two error	M7165
1 0 1 1 x x x x	x x x x 1 0 1 1	Hex B; undefined	Undefined
x x x x 1 1 0 0	1 1 0 0 x x x x	Hex C; Timeout error, check error code in SA register (Refer to KDA50-Q Service Manual)	Many causes
1 1 0 1 x x x x	x x x x 1 1 0 1	Hex D; RAM parity error	M7165
1 1 1 0 x x x x	x x x x 1 1 1 0	Hex E; ROM parity error	M7164
1 1 1 1	1 1 1 1	Hex F; sequencer error	M7164
Cycling pattern	Cycling pattern	None	No problem ***

INSTALLATION

Table 2-2 (cont.)

M7164 LEDs*	M7165 LEDs*	Error Symptoms	Most Likely Failure
8 4 2 1	8 4 2 1		

*** During a cycling pattern, the LEDs flash one at a time starting at the LSB and progressing through the MSB. These LEDs begin flashing on the M7164 module, then progress to the M7165 module. However, the pattern is executed very fast so it looks like all the LEDs are flashing at the same time. The flash goes on and off for approximately 1/4 second and then repeats at about a 4 second rate. The LEDs normally cycle while the KDA50-Q is waiting for the host to start the initialization process. At that time, it responds to the initialization and the cycling pattern stops. This normally occurs in about four seconds, if the system software is prepared to establish a connection with the KDA50-Q.

Note: 1 = LED ON 0 = LED OFF x = May be ON or OFF

When two codes are given for the same error, both indicate the same failure.

2.5.1 Drive-Resident Diagnostics

Each disk drive should be tested separately by running the drive-resident diagnostics. The procedure for running the resident diagnostics is found in the installation chapter of the disk drive user guide. Perform the drive field acceptance tests found in the installation chapter and then go to Paragraph 2.5.2 for the subsystem diagnostic procedures.

2.5.2 Subsystem Diagnostics

The subsystem diagnostic procedures for the KDA50-Q controller differ when they are used on a PDP-11 CPU or a VAX CPU. The following paragraphs cover the PDP-11 diagnostics first and then the VAX diagnostics.

NOTE

If the diagnostic program reports errors, refer to the KDA50-Q Service Manual.

INSTALLATION

CSR ADDRESS OF CONTROLLER (O) 172150 ?

NOTE: CSR=IP.

VECTOR (O) 154 ?

BR LEVEL (D) 5 ?

NOTE: The KDA50-Q ignores this question and automatically reassigns the appropriate BR LEVEL of 4.

DRIVE NUMBER (D) 0 ?

Sample CZUDI hardware prompts:

CHANGE HW (L) Y ?

UNITS (D) 1 ?

UNIT 0

CSR ADDRESS OF CONTROLLER (O) 172150 ?

DRIVE NUMBER (D) 0 ?

EXERCISE ON CUSTOMER DATA AREA (L) N ?

Sample CZUDH software prompts:

CHANGE SW (L) Y ?

ENTER MANUAL INTERVENTION MODE IN TEST 2 (L) N ?

Sample CZUDI software prompts:

CHANGE SW (L) Y ?

ENTER MANUAL INTERVENTION MODE FOR SPECIAL DIAGNOSIS (L) N ?

ERROR LIMIT (D) 32 ?

READ TRANSFER LIMIT IN MEGABYTES - 0 FOR NO LIMIT (D) 0 ?

SUPPRESS PRINTING SOFT ERRORS (L) Y ?

DO INITIAL WRITE ON START (L) Y ?

ENABLE ERROR LOG (L) N ?

INSTALLATION

2.5.2.2 VAX Subsystem Diagnostics -

- o EHRAD (KDA50-Q Disk Drive Formatter)

EHRAD is not a diagnostic. Do not run it unless specifically instructed to.

- o EHRAA (KDA50-Q Basic Subsystem Diagnostic)

EHRAA consists of the following three tests:

- o Test 1 -- BUS Addressing test
- o Test 2 -- Disk-Resident Diagnostic Test
- o Test 3 -- Disk Functional Test

- o EHRAB (Disk Exerciser Test)

- o EHRAC (Subsystem Exerciser Test)

This program tests the read and write ability of any SDI type disk drive from a KDA50-Q, and will display differences in the read and write data to the operator.

2.6 SYSTEM AND SOFTWARE CONSIDERATIONS

2.6.1 System Clock Or Timer

Some aspects of both diagnostic and/or functional usage of a KDA50-Q depend upon the ability of the host processor to time-out on an operation. It is recommended that clock interrupts be enabled. Check host processor documentation for appropriate instructions.

2.6.2 Error Logs

The KDA50-Q has the capability to return information to the operating system for inclusion into an error log. These entries may include specific information on the operation of the KDA50-Q, its attached drives, or other parts of the system (host processor, memory, software, etc.) which may be important in diagnosing the source of possible problems. It is recommended that error logging be enabled in your operating system to take advantage of such information. Consult your operating system

INSTALLATION

documentation for appropriate information on the enabling of error logs.

Some reports contained in the error log may represent changes in the configuration or operation of your system that are informational in nature, and thus may not represent the occurrence of an error condition. Examples of this may be:

- o completion of the initialization sequence between the port driver and the KDA50-Q
- o attention messages pertaining to the availability of a disk drive (which may be the result of changing a drive's unit number)

2.6.3 Drive Numbering

DSA/SDI drives that can be connected to the KDA50-Q can usually be given a unit number ranging from 0 to 254. Some operating systems do not support this entire range of unit numbers, sometimes only supporting the range 0 to 7. Consult operating system documentation for appropriate capability, and drive documentation for how to specify unit numbers.

The unit numbers assigned to drives attached to a KDA50-Q do not imply any priority, or other special property; all drives are treated equally by the KDA50-Q. The only requirement on unit number assignments is to avoid duplicating a unit number on two different drives, which could lead to confusion by an application or user. The KDA50-Q will not permit a drive to be accessed if its unit number duplicates another drive's number while the second drive is also attached. This situation may be corrected by changing either (or both) of the duplicating numbers.

Unit numbers can usually be easily changed at the drive, although this is recommended only when the intended drive is not online (not mounted by the operating system) to the KDA50-Q.

2.6.4 System Performance And Operation

Consult the QBUS sections in this Chapter for information pertaining to KDA50-Q features and placement which may bear on performance or operation of your system.