

**GENERAL
ELECTRIC
GARDE
DATA PROCESSING
SYSTEM
TAILORED FOR
ELECTRIC
UTILITY
STEAM
PLANTS**

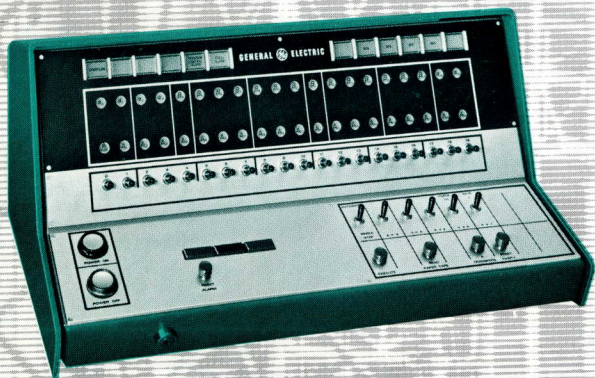

**PROCESS COMPUTER SECTION
INDUSTRY CONTROL DEPARTMENT
PHOENIX, ARIZONA**

GENERAL  ELECTRIC

GARDE

GATHERS

ALARMS

RECORDS

DISPLAYS

EVALUATES

IN THE CONSTRUCTION OF THE EQUIPMENT
DESCRIBED, GENERAL ELECTRIC COMPANY
RESERVES THE RIGHT TO MODIFY THE DESIGN
FOR REASONS OF IMPROVED PERFORMANCE
AND OPERATIONAL FLEXIBILITY

TABLE OF CONTENTS

| | Page |
|--|------|
| ADVANTAGES OF THE GENERAL ELECTRIC GARDE SYSTEM FOR POWER PLANT DATA PROCESSING..... | 1 |
| THE GARDE SYSTEM..... | 2 |
| WHAT IS A STEAM PLANT DATA PROCESSING SYSTEM?..... | 3 |
| Gathering and Preparing Information..... | 3 |
| Digital Computer..... | 3 |
| Operator's Control..... | 3 |
| Program Control..... | 3 |
| FUNCTIONS OF THE GARDE SYSTEM..... | 5 |
| Gathers System Information..... | 5 |
| Alarms All Off-Normal Quantities..... | 5 |
| Reports System Operation..... | 6 |
| Displays Pertinent Information..... | 6 |
| Evaluates Plant Operation..... | 7 |
| Boiler Efficiency..... | 7 |
| Turbine-Generator Heat Rate..... | 7 |
| Station Heat Rate..... | 8 |
| Correction of Heat Rates to Reference Conditions..... | 8 |
| High Pressure and Intermediate Pressure Turbine Efficiency..... | 8 |
| Feedwater Heater and Other Heat Exchanger Equipment Performance..... | 8 |
| Condenser Performance..... | 8 |
| DESCRIPTION OF GENERAL ELECTRIC GARDE SYSTEM EQUIPMENT..... | 9 |
| Process Input Section..... | 11 |
| Computer Section..... | 11 |
| Operator's Control Section..... | 13 |
| Options..... | 13 |
| Program Control Section..... | 13 |
| System Availability..... | 13 |
| Over-all System Accuracy..... | 16 |
| PRINCIPLES OF OPERATION..... | 17 |
| Computer..... | 17 |
| Single Address Instruction..... | 18 |
| 1 + 1 Instruction..... | 18 |
| Instruction Modification..... | 18 |
| Information Flow To and From the Computer..... | 21 |
| Operator's Control Section..... | 21 |
| Automatic Printout of Point Identification and Point Value..... | 24 |
| Automatic Printout of Step Number of Start-up or Shut-down Sequence (Optional)..... | 24 |
| On Demand..... | 24 |

TABLE OF CONTENTS (Continued)

| | Page |
|--|------|
| Options to Operator's Control Section..... | 24 |
| Process Input Section..... | 28 |
| Analog Signals..... | 28 |
| Contact Closures..... | 28 |
| Pulse Signals..... | 29 |
| Program Control Section..... | 29 |
| Programming and System Checking..... | 29 |
| Executive Program..... | 31 |
| Normal Operation..... | 31 |
| Guiding and Monitoring of Start-up and Shut-down Procedures- Recommended Option... | 31 |
| Performance Calculations..... | 32 |
| Allocation of Computer Time..... | 32 |
| GARDE System Service Routines..... | 32 |
| GE 312 Diagnostic Routines..... | 32 |
| GE 312 Computer Checking Features..... | 33 |
| GARDE SYSTEM MATERIAL AND SERVICES..... | 34 |
| SPECIFICATION SUMMARY FOR THE GE GARDE UTILITY SYSTEM..... | 35 |



LIST OF ILLUSTRATIONS

| Figure No. | Title | Page |
|------------|--|--------|
| 1. | Functions of the GARDE System..... | 4 |
| 2. | Equipment Operation Evaluated by General Electric GARDE System Performance Calculations..... | 9 |
| 3. | General Electric GARDE System for Steam Electric Power Plant Data Processing..... | 10 |
| 4. | GE 312 Computer Showing Self-Contained Air Conditioning, Drum Memory and Plug-In Board..... | 12 |
| 5. | Operator's Control Panel for GARDE System..... | 14 |
| 6. | Console, Typewriter, Paper Tape Punch and Paper Tape Reader Make Up the GARDE System's Program Control Section..... | 15 |
| 7. | Pull-Out Printed Wiring Circuit Boards Facilitate Routine Maintenance..... | 16 |
| 8. | Modern Wire-Wrap Technique Eliminates Failure Because of Cold- Soldered Joints..... | 17 |
| 9. | Transistors and Components on Printed Wiring Boards Operate at Fraction of Their Rated Performance..... | 17 |
| 10. | Information, Flow General Electric GARDE System..... | 20 |
| 11. | Typical Log Sheet..... | 22, 23 |
| 12. | Overall Program Flow..... | 30 |

LIST OF TABLES

| Table No. | Title | Page |
|-----------|-----------------------------|------|
| 1. | GARDE System Registers..... | 19 |
| 2. | Alarm Printer Code..... | 25 |
| 3. | Alarm Printing Formats..... | 26 |

The General Electric GARDE System for Power Plant Data Processing

Improves Efficiency

Provides operator with current operating data, warns immediately when out-of-limit condition occurs, delivers performance results soon enough for possible adjustments to improve fuel economy.

Reduces Maintenance

Helps operator to pinpoint trouble, usually before it is serious, through access to more complete process information and by early detection of off-normal plant variables. Reduces stresses by better treatment of boilers, turbines, and generators through computer supervision of operation.

Increases Reliability and Safety

Reduces possibility of catastrophic damage caused by operating error. Alerts operator as condition approaches danger point, allowing more time for manual corrective action to avoid or minimize damage.

Upgrades Manpower Utilization

Relieves plant operators from routine tasks, provides them greater knowledge of complex plant control, and helps develop their skill in proper plant operation.

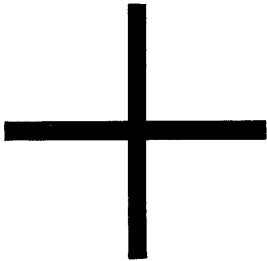

Increases Savings

Offers savings in plant design through decreased instrumentation and savings in plant operation through better efficiency, greater reliability, and less maintenance. The lower forced outage rates possible for units protected by the GARDE System may save substantially in generation reserve investment.



GARDE

The GARDE System

1. Gathers data to central location.
2. Computes hourly overall heat rate and component efficiencies with high accuracy.
3. Checks unit for dangerous operation.
4. Checks operating values for out-of-limit conditions.
5. Varies limits automatically with process changes.
6. Prepares log automatically.
7. Records values exceeding pre-set limits automatically.
8. Adjusts to new conditions through program flexibility.

Options

9. Guides unit operation including monitoring of start-up and shut-down procedure.
10. Records trends of selected process variables or computed values.

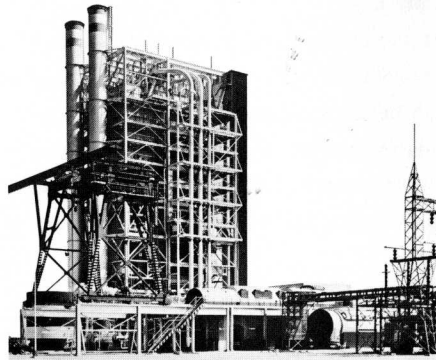
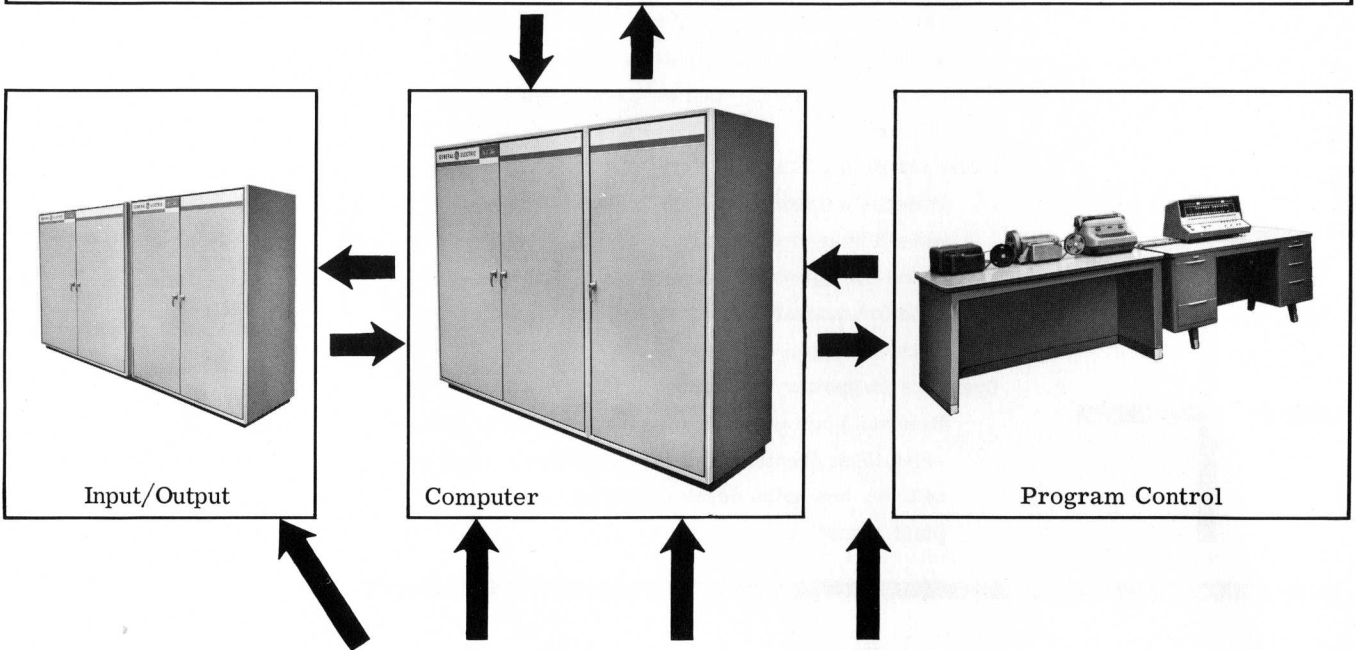
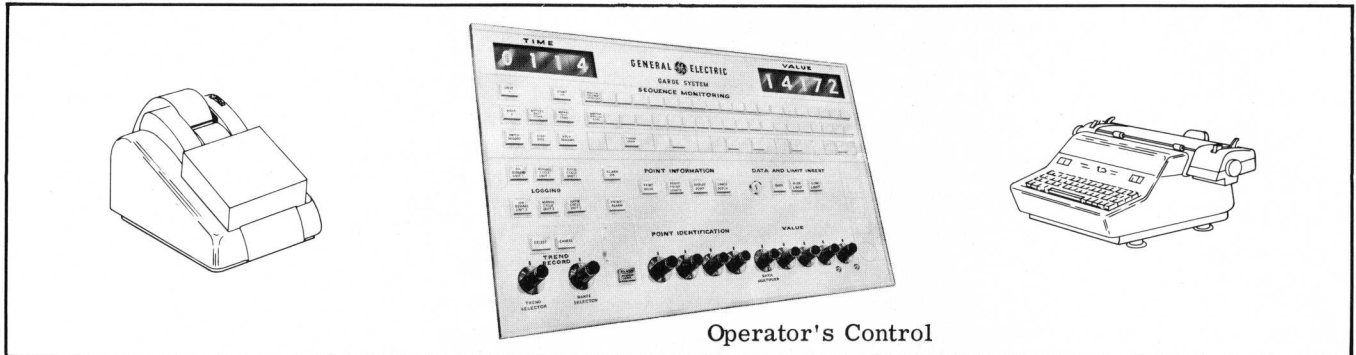

WHAT IS A STEAM PLANT DATA PROCESSING SYSTEM?

A Data processing system reduces large amounts of information into a concise and useful form. In the past decade, data processing has revolutionized the business world. The same functions are needed in the steam plant, but the problems and conditions are different. For example, data should be obtained and processed in real time (as it is generated) to aid plant operation. Also, the system should operate reliably 24 hours a day, 365 days a year.

A computer data processing system for a power plant has four main categories:

The portion devoted to gathering and preparing information for the computer from a large number of sensors in the plant.

The digital computer, with its stored program, which processes data and directs the gathering, logging, and display of information.

The means available to the operator for inserting information into the computer and requesting data from it, and the operator's output equipment such as typewriters, printers, displays, etc.

The means available for initial insertion or changing of the stored program in the computer, and the program input/output equipment including paper tape punch and reader, typewriter, etc.

In a business data processing system, information comes from files and is stored on cards and tapes. In steam plant data processing, nearly all of the information comes from sensors located on the plant equipment. The electrical signals or "outputs" from these sensors or their transducers, are wired directly to the input section of the data processing system. Some examples of the sensing devices used to supply the input information are; thermocouples for temperature detection, thermoverters for electrical measurements, and transducers for pressure flow, and other indicators.

Gathering and Preparing Information

The portion of the system which does this includes the equipment for selecting the inputs from the sensors one at a time and scaling and converting their readings to a form acceptable by the computer. The equipment is called a scanner, and its operation is called "scanning" the input signals. The computer accepts only binary digital numbers, a number system consisting of 1's and 0's. Contact closures and pulse signals are already in this form. Analog signals, such as those produced by thermocouples, are changed to the binary digital form by a device called the analog-to-digital converter.

Digital Computer

The digital computer consists of:

- a memory for storing the program and data.
- registers for temporary storage and control.
- an arithmetic unit for calculations.

Operator's Control

The operator's control permits:

- immediate alarm and location of plant trouble.
- insertion of data or limits for process variables.
- routine inspection of process readings for controlling plant operation.

An alarm printer, logging typewriter and visual display are the operator's sources for obtaining plant data. Panel mounted control switches provide means to change limits and insert data into the computer.

Program Control

Program control provides:

- initial insertion of the program in the computer.
- modification of the program.
- computer system maintenance and diagnostics.

A paper tape punch operated from the typewriter converts the written program into a tape used by a tape reader. A paper tape reader is the means used

to load the program into the computer. Also, the computer system can send information out to be punched on paper tape or typed when so instructed by the program. Program control switches allow single step operation and data insertion for com-

puter system and program diagnostics. This preliminary introduction is to aid understanding of the approach used in a typical system. Data processing will be discussed at greater length in the following material.

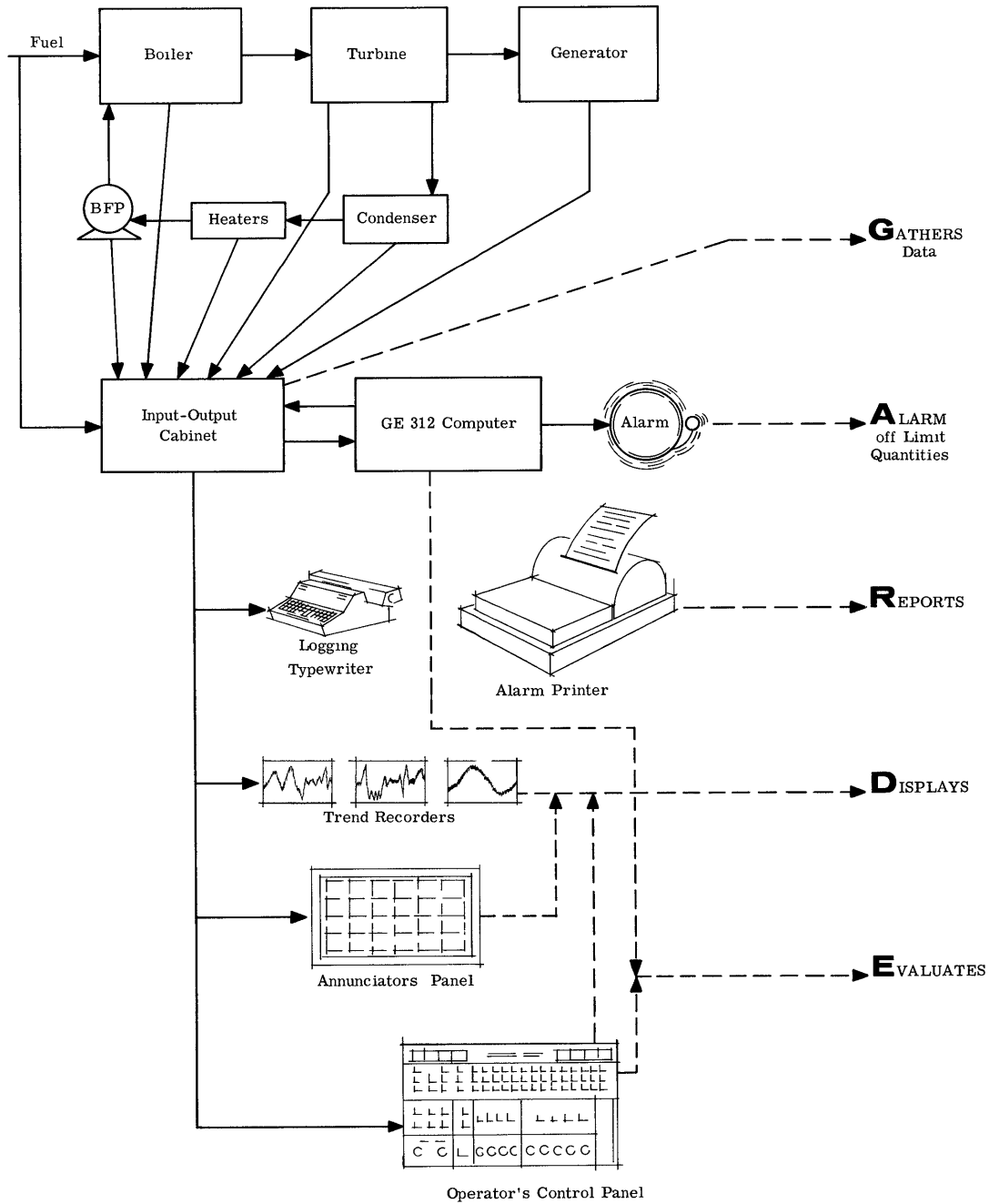

Figure 1. Functions of the GARDE System

General Electric brings you the GARDE System, a data processing computer system tailor-made for steam power plants. The basic GARDE System, as described here, provides equipment required for one unit, but is expanded easily for serving two units. Relatively little additional equipment is needed for the double duty.

General Electric leads all manufacturers in computer systems installed or ordered by the Electric Utility Industry. From this experience, General Electric engineers determined the functions normally used or desired in steam plant on-line data processing. They have now designed a standard system to fulfill the usual requirements. The GARDE System is the result.

Early detection of difficulty in a steam power plant and reduced stresses on boilers, turbines and generators which result when the GARDE System is used mean the rate of unit forced outage will be lower. Lower forced outage rates mean that total reserve generation required on a power system will be less. When properly evaluated, the savings in generation reserve investment together with decreased plant design and operating expense mean that the GARDE System can pay its own way.

The name GARDE was chosen because the system:

- Gathers data,
- Alarms,
- Reports,
- Displays and
- Evaluates

It is built around the powerful, proven GE 312 Computer, and features:

- large capacity process input section for analog, digital and pulse signals.
- large drum memory, 24,000 words with basic system.

- memory expansible to 54,000 words (adequate for two unit application).
- industrial construction throughout.
- completely transistorized.
- high availability.
- convenient, human-engineered operator control section.
- programming package including all GARDE System functions.

Gathers System Information

The GARDE System automatically brings to the operator's fingertips the information he needs to supervise the plant. It gathers the information by sequentially scanning plant sensors. The selection of the inputs and the scan frequency is controlled by a programmed scan routine in the central processor of the GARDE System. The maximum analog scan rate used for continuous scanning is 20 points per second; but at this rate, the system is not available to do other functions. The average scan rate is eight analog and 100 digital points per second; however, the scan rate for any analog point may be more or less frequent, depending on the nature of the input.

Alarms All Off-Normal Quantities

The GARDE System automatically warns the operator when a value - measured or computed - goes out of preset limits. Analog input values and computed quantities are checked against high/low limits as each point is scanned, and contact inputs are checked for proper status. The operator makes the required adjustments to plant controls when they are needed. This stabilizes operation at the preset values. The system functionally improves with age because the stored program can be modified as new and better procedures develop.

A Flashing light on the control panel warns the operator when a value exceeds preset limits. The GARDE System can also actuate an audible alarm on an annunciator panel. The light stops flashing when the operator presses an acknowledge button, but a steady light remains on as long as any value is out of preset limits. When a print alarm button is pressed, all values exceeding limits are printed out on an alarm printer. A value which exceeds a preset limit for the first time will be automatically printed out on the alarm printer. The alarm print-out information includes the time, point identification, type of variable, such as temperature (T), and value. The format is described in a later section.

When the point returns within limits, it will again be printed out. A returned-to-normal point or an "on-demand" printout is in black; an off-normal point printout is in red.

Reports System Operation

The GARDE System automatically prepares a complete log, a record of all points exceeding preset limits, and a record of all limit changes.

The complete log is normally printed once an hour; but the operator may change to a faster log cycle, or he may request a complete log anytime he chooses. The log contains several computed values as well as the routine measured information from the process. For example, there are such items as boiler efficiency and turbine generator heat rate. These indicate efficient operation much better than the traditional pressures, temperatures, and flows. Now that power plants are using computers for on-line data processing, performance measurements soon will become the important operating criteria.

Points exceeding preset limits and limit changes are recorded on the alarm printer, as described in the preceding section. This method of recording often replaces the traditional strip recorders on new units. Many strip charts have little historical value--as long as operation is within limits. A much more convenient and concise record is provided by the alarm

printer. A single strip of paper containing only the pertinent information replaces the vast quantity of paper, most of which tells nothing new.

As an added benefit, the GARDE System detects faulty sensors. It automatically checks thermocouples every 15 minutes and notes on the alarm printer if an open is detected. Also, key sensors are checked for unreasonable values.

Displays Pertinent Information

The operator may call for visual display or printout of the value in engineering units of any point on demand. The visual display is continuous and up-dated each time the value is scanned. Computed values, when displayed, are normally calculated and up-dated once a minute.

The unit operation guide is a recommended option available with the GARDE System. It includes a visual display of lighted nameplates and pushbuttons to direct the operator in complex sequences of turbine-generator unit operation. This optional package consists of a sequence monitor panel supplied with the operator's control panel and a group of programs for checking the operator in the following:

- Start-up sequence
- Shut-down sequence
- Boiler warmup rate
- Turbine acceleration rate
- Generator loading rate

The visual display, called the sequence monitor, effectively looks over the shoulder of the operator as he opens valves, starts pumps and so on. The stored sequence procedures in the computer check for completeness and for critical out-of-sequence operations. The operator receives visual signals from the sequence monitor panel during correct operation, and alarms and printouts during misoperation.

The pushbuttons available on the panel allow the operator to advise the computer when he is commencing one of the procedures. A row of twenty backlighted

windows for both "START-UP" and "SHUT-DOWN" provide the visual displays for each sequence. Each window is custom printed to describe the step in the sequence it represents. When lighted the window indicates that the conditions necessary to fulfill that step are proper and that the operator may proceed to the next step. This continues until all twenty have been lighted in sequence.

Three pushbuttons labelled "BOILER WARMUP", "TURBINE ACCELERATION", and "GENERATOR LOADING" are positioned in a third row along the two rows of windows so they lie just below the sequence position at which each of the operations indicated would begin. When the sequence has progressed to this point, and the window is lighted, the computer waits until the operator pushes the button before continuing the sequence.

Pressing one of these buttons, such as "BOILER WARMUP", tells the computer that the operator is commencing the operation. The computer then brings in a set of subroutines with which it compares the actual rate of boiler warmup with a rate predetermined as best for the boiler, and programmed in the computer as a series of time-temperature slopes. The computer determines the difference and sends out a signal to a zero center panel indicator located on the main control board. This visually indicates to the operator whether he is fast, slow or on schedule. If he deviates too far from the proper schedule, alarms will be initiated and the program will reposition itself to where the operator is on the rate curve. This prevents him from attempting a fast correction to eliminate the error.

A very important feature of this option is that the printer records the time when each step is completed. This time record provides the information needed to analyze the procedure.

The unit operation guide gives the GARDE System the ability to consider the characteristics and limitations of boilers, turbines, and generators, thereby reducing the wear and maintenance requirements

and increasing the reliability of this valuable equipment.

Trend records of selected process or computed values are recommended options. The operator then may have a continuous record of values he selects for trend recording on conveniently located miniature strip charts to further aid his supervision of the unit. These records are quite useful for engineering analysis especially following periods of upset or when rapid operational changes are made.

Evaluates Plant Operation

The GARDE System evaluates plant operation through the following key performance calculations: (Figure 2.)

- Boiler efficiency
- Turbine generator heat rate
- Station heat rate
- Correction of heat rates to reference conditions
- High pressure and intermediate pressure turbine efficiency
- Feedwater heater and other heat exchanger equipment performance

The computer usually calculates this information hourly, from data averaged over the period since the last calculation. If the operator requests the information during the hour, calculations are based upon shorter time periods.

Boiler Efficiency

Two methods are available for computing boiler efficiency: input/output method and heat-loss. The input/output method is preferable for either gas or oil-fired boilers because of the relative ease and accuracy with which the fuel flow can be measured. The heat-loss method is used for coal-fired boilers because of the difficulty in obtaining accurate, short-time fuel input measurements.

Boiler efficiency is given by the formula:

$$\text{Boiler Efficiency} = \frac{\text{Net energy from boiler to turbine}}{\text{Energy to boiler from fuel}} \times 100$$

Turbine-Generator Heat Rate

Net turbine-generator heat rate is the number of

BTU's per hour supplied to the turbine per net KW supplied to the system. Net KW is obtained from kilowatt hour meter reading by the formula:

$$\text{Net KW} = \frac{\text{Net KWHR}}{\text{Hours}}$$

$$\text{Net Turbine-Generator Heat Rate} = \frac{\text{BTU/Hr.}}{\text{Net KW}}$$

Although the calculation is shown for net heat rate, the gross turbine-generator heat rate can be obtained using gross KW instead of net.

Station Heat Rate

The station heat rate is the number of BTU's per hour supplied by the fuel to the boiler per net KW supplied to the system. Both of these quantities are available as used for the boiler efficiency and turbine-generator heat rate calculations.

$$\text{Station Heat Rate} = \frac{\text{BTU/Hr. to Boiler}}{\text{Net KW}}$$

Correction of Heat Rates to Reference Conditions

The heat rate calculations are referenced to standard conditions of temperature and pressure, otherwise comparisons with past results would not be meaningful. The factor to reference the heat rate calculations is a function of condenser vacuum and deviation of steam temperature and pressures from rated conditions.

High Pressure and Intermediate Pressure Turbine Efficiency

An indication of turbine performance is given by the computation of the high and intermediate pressure turbine efficiencies. These efficiencies are given by the relationships:

$$\text{High Pressure Turbine Efficiency} = \frac{H_{ms} - H_{crh}}{H_{ms} - H'_{crh}} \times 100$$

$$\text{Intermediate Pressure Turbine Efficiency} = \frac{H_{hrh} - H_{co}}{H_{hrh} - H'_{co}} \times 100$$

where:

H_{ms} = enthalpy of main steam

H_{crh} = enthalpy of cold reheat steam

H'_{crh} = isentropic end point enthalpy of cold reheat steam

H_{hrh} = enthalpy of hot reheat steam

H_{co} = enthalpy of steam at crossover to low pressure turbine

H'_{co} = isentropic end point enthalpy of steam at crossover

Feedwater Heater and Other Heat Exchanger Equipment Performance

The performance of feedwater heaters is monitored by computing the drain cooler and terminal differences of the individual heaters and checking them against designed performance.

The performance of other heat exchanger equipment such as the economizer and reheaters, can be checked by monitoring temperature differentials across the pieces of equipment. Generally, the expected temperature differential will vary as a function of load.

Condenser Performance

Condenser performance is checked by monitoring the operating outlet temperature of the circulating water.

The difference between the measured outlet temperature and the bogey outlet temperature can be checked against a variable alarm limit as a function of condensate or feedwater flow.

DESCRIPTION OF GENERAL ELECTRIC GARDE SYSTEM EQUIPMENT

The General Electric GARDE System is an advanced, fully transistorized data processing system. The basic system is designed for one Boiler-Turbine-Generator (BTG) unit; but it may be expanded to

monitor two units. The GARDE System has four principal parts:

1. Process Input Section
2. Central Computer Section
3. Operator's Control Section
4. Program Control Section

(See Figure 3.)

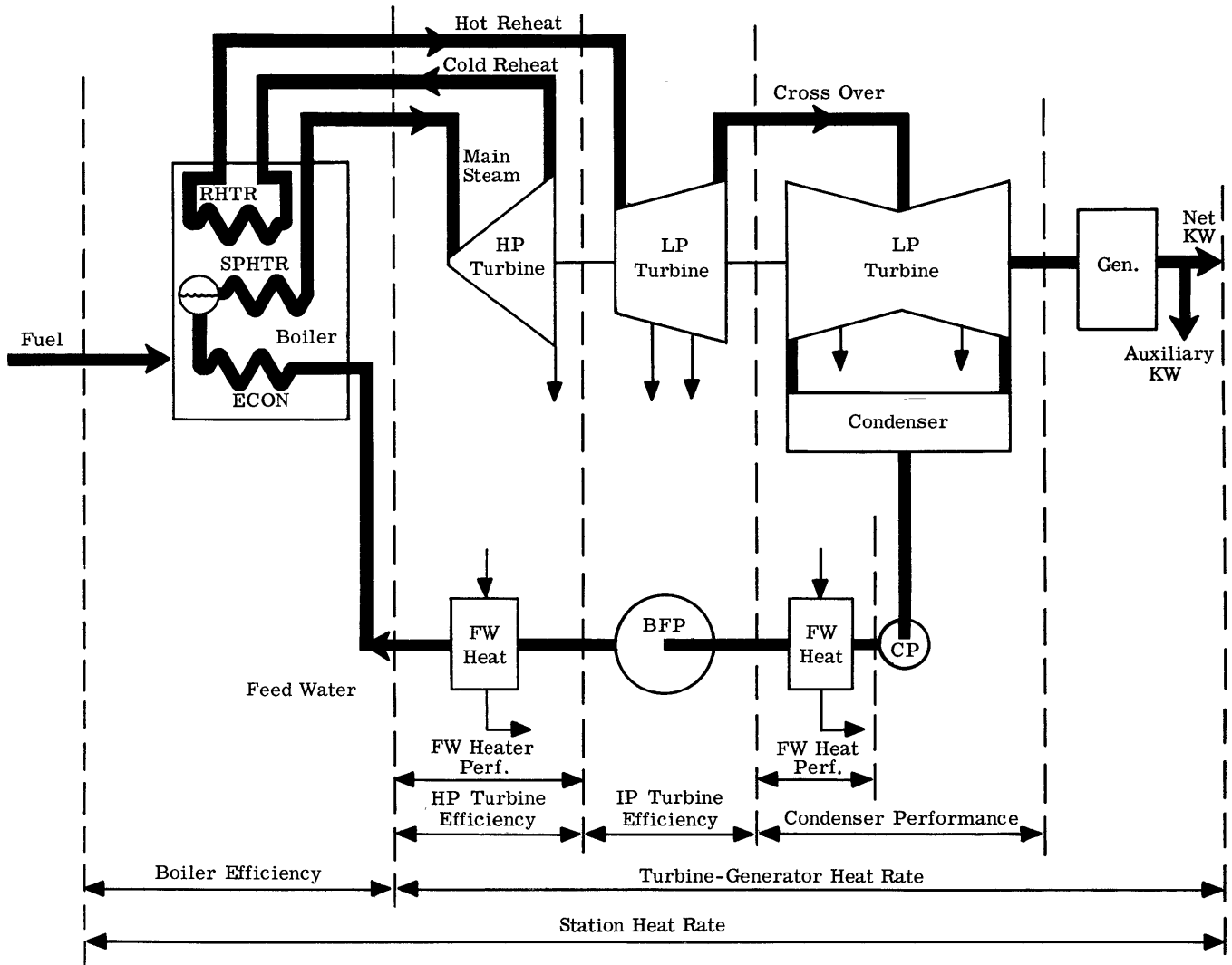

Figure 2. Equipment Operation Evaluated by General Electric GARDE System Performance Calculations

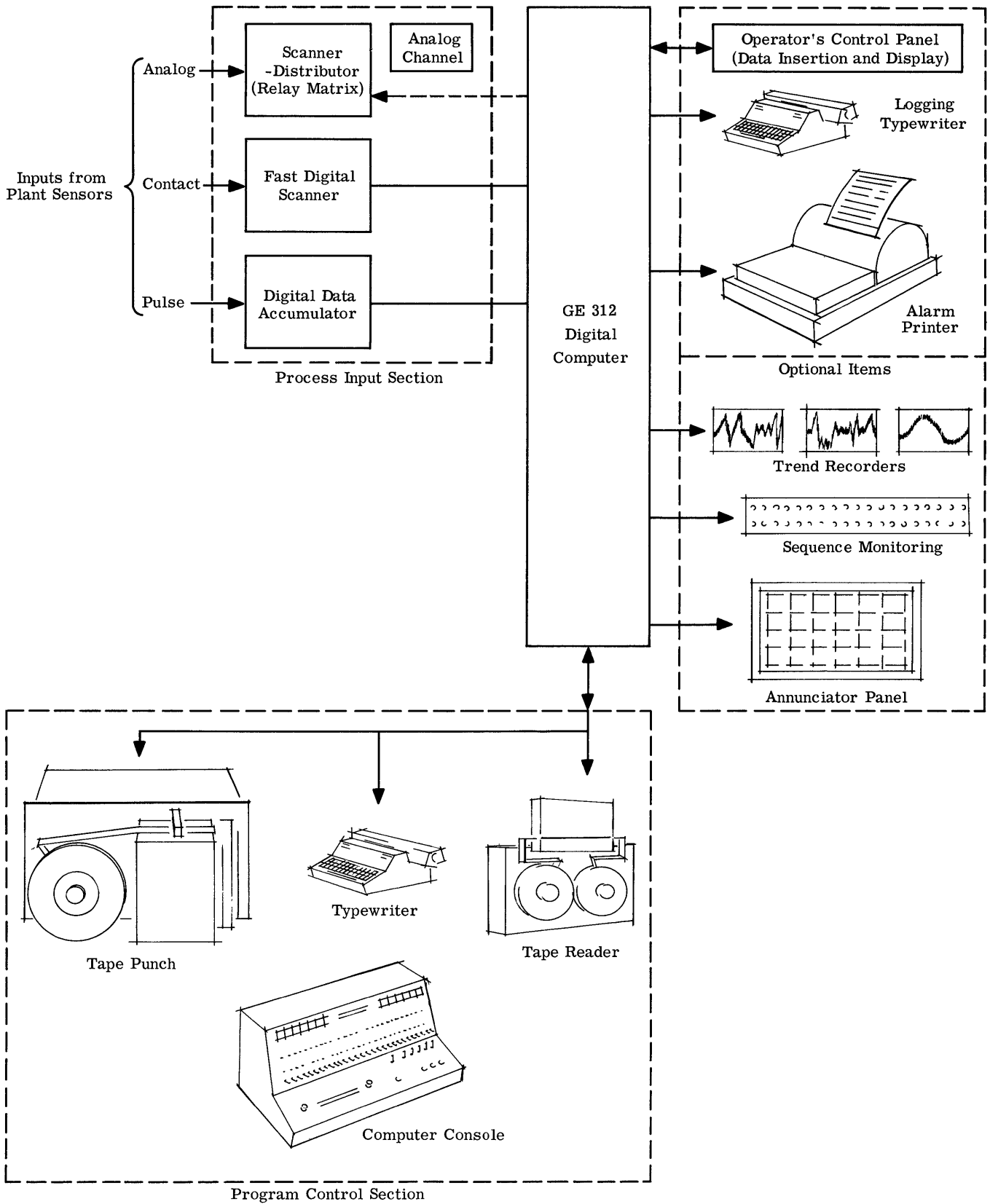

Figure 3. General Electric GARDE System for Steam Electric Power Plant Data Processing

Process Input Section

The Process Input Section consists of four cabinets containing equipment designed to receive signals from plant equipment and condition them to a form useable by the computer. Three types of input signals are accommodated: analog, contact, and pulse.

Analog inputs must be in the form of dc voltages. Signals from 10 millivolts full scale to 250 volts full scale can be handled. In some cases, it is necessary to add transducers to convert signals from plant sensors to dc voltage. Once a signal is converted to the "common language" of a dc voltage, it is sampled (scanned) by the Scanner/Distributor, a mercury-wetted relay matrix. When an input is sampled, it is connected to an analog channel for scaling to the proper level for input to the analog-to-digital converter. The analog-to-digital converter changes the signal to a digital binary number which is accepted as input by the central computer. All input operations are under control of the computer program.

A Thermocouple Reference Unit is provided to give an accurately measured cold junction for plant thermocouples.

Plant contacts are sensed in groups of 20 at high speed by the Fast Digital Scanner to determine if they are open or closed. Through the Digital Scan Register, the central computer can select any one of five groups. The scanning speed is 12.5 milliseconds per set of 20 contacts. The computer determines by means of a comparison technique whether the contact status of the group is correct. If not, it alarms and prints out the point identification of the off-normal contact.

Pulse signals to be simply counted come from plant devices such as KWH meters and coal scales. These pulses may be counted and stored temporarily by the Digital Data Accumulator (DDA). Binary counters are used to accumulate the pulses. The counters are sampled periodically by the central com-

puter where cumulative totals are kept for this data.

Computer Section

The Computer Section consists of the GE 312, a stored program binary digital computer. The GE 312 is designed specifically for industrial and utility applications and is packaged in three cabinets matching the process input cabinets. Air conditioning is included where necessary.

Distinctive features include automatic address modifications, fast access, and versatile command structure. For descriptive purposes, the computer internal equipment can best be subdivided into three functional categories:

- Arithmetic Unit
- Control Unit
- Memory Unit

The arithmetic unit does the numerical operations of the computer with logic circuitry and registers for temporary storage of numbers. Logical decisions are also made in this unit by the manipulation and comparison of binary numbers.

The control unit directs the operation of the computer in carrying out the instructions of the program. It consists of three registers and circuitry for instruction decoding and sequencing. The registers are for automatic address modification and temporary storage of memory locations for data and instructions.

The memory unit contains the computer program instructions and data as separate, distinct numbers in randomly addressable locations. It consists of a revolving drum with a coating of magnetically sensitive material around the surface and several read-write heads. A head writes information on the drum surface by magnetizing a small area representing a binary digit. The head reads the information by detecting the direction of magnetism of the location. Combinations of the magnetized bits organized in tracks and sectors for address assignments represent the computer words in memory. A magnetic

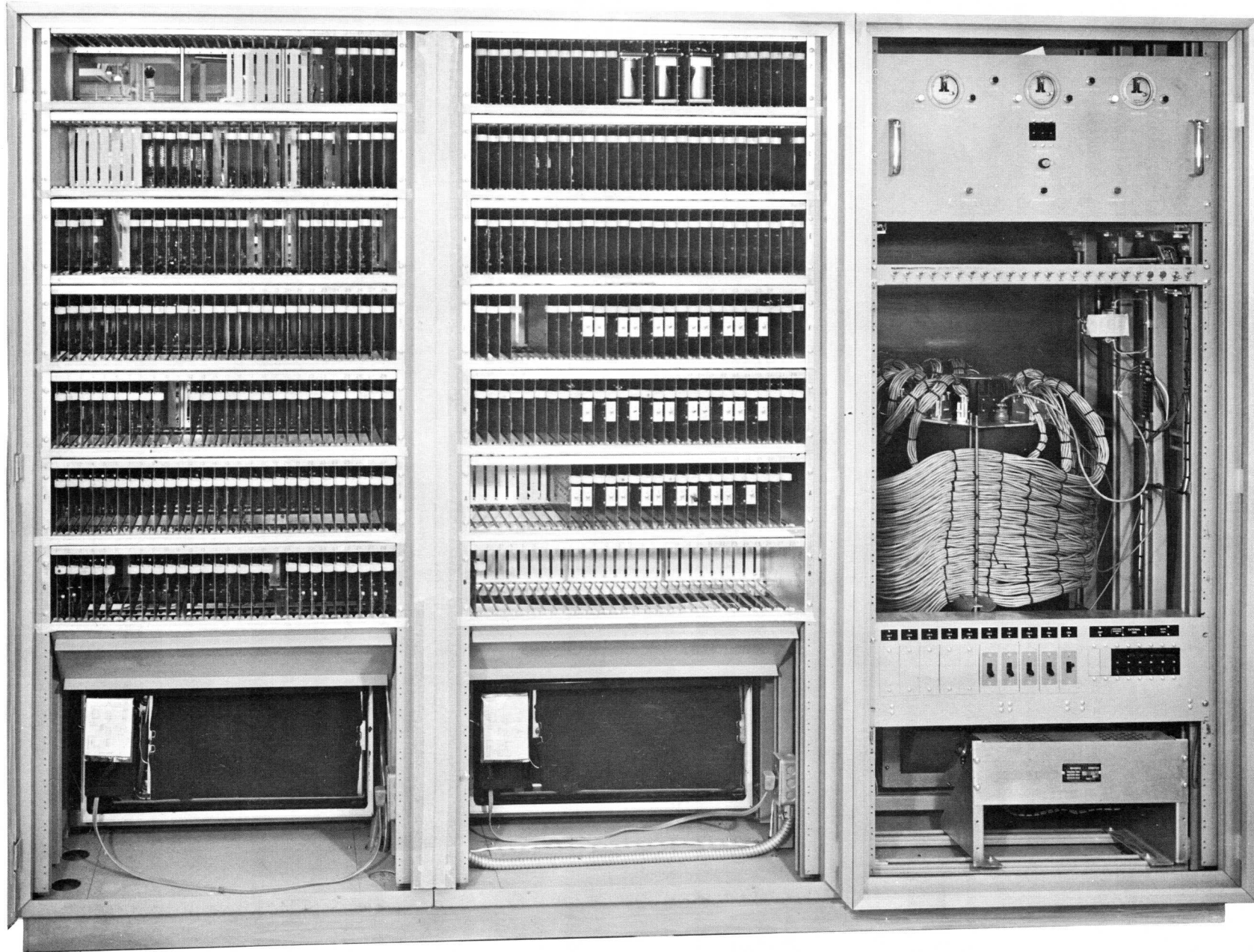

Figure 4. GE 312 Computer Showing Self-Contained Air Conditioning, Drum Memory and Plug-In Boards

drum memory features large storage capacity and positive program protection through retention of complete memory during power failure.

Operator's Control Section

The operator's control section consists of a control panel, logging typewriter, and alarm printer. The control panel is usually mounted on the Boiler-Turbine-Generator control board and the typewriter and printer placed nearby.

The operator's control panel (see Figure 5.) is designed to give the steam plant operator information and control on one convenient, compact unit. With this control, an operator having no computer knowledge is able to perform normal operations such as change limits, enter data, and obtain information on demand. All switches and buttons have decimal and common language notations. The panel has a key-operated switch for entering data or limits into the computer program. Only authorized personnel are issued keys to this switch. The alarm printer provides a permanent record of insertion of all data or limits, allowing the operator to check all entries for correctness.

Specifically the operator's control section:

1. Informs
 - as point value goes out of preselected limits.
 - continuously as long as any point is out of preselected limit.
2. Displays continuously
 - time of day in hours and minutes.
 - value of data point selected.
3. Permits data entry into the computer program
 - High alarm limit
 - Low alarm limit
 - Process information
4. Provides on-demand print-out
 - Data point value
 - Point alarm limits
 - Data point and value of all points out of limit.
 - Complete log

Point and value of reading selected for digital trend.

Point, scaling factor, and chart center value when trend recorder selected (optional).

Point and value of all items preventing advance of start-up or shut-down monitoring (optional).

5. Selects
 - Logging cycle
 - Trend recorder (optional)
 - Sequence to be monitored (optional).

Options

Available for the Operator Control Section are optional equipments and programs to provide:

1. Trend records of measured or computed values.
2. Sequence monitoring panel mounted with the operator's control panel to aid start-up and shut-down. With its allied programs, this is the Unit Operating Guide option previously described.
3. Annunciator panel.

Program Control Section

The program control section consists of the computer console, automatic 20" typewriter, paper tape punch, and paper tape reader. It is used initially to read the programs into the computer; and subsequently, for check-out, maintenance, and program modification. This section is used primarily by persons skilled in programming and computer operation. It is usually not physically in the operator's control section. It should be located nearby, however, because the computer typewriter may be used as an on-line spare for the logging typewriter. The Program Control Section is shown in Figure 6.

System Availability

The GARDE System is designed for high availability. On-line spares are provided for the alarm printer and the logging typewriter; all transistors and other computer components are conservatively derated to operate at only a fraction of their nominal ratings. The system is ruggedly constructed for industrial use; cabinets are of heavy-gage steel with channel

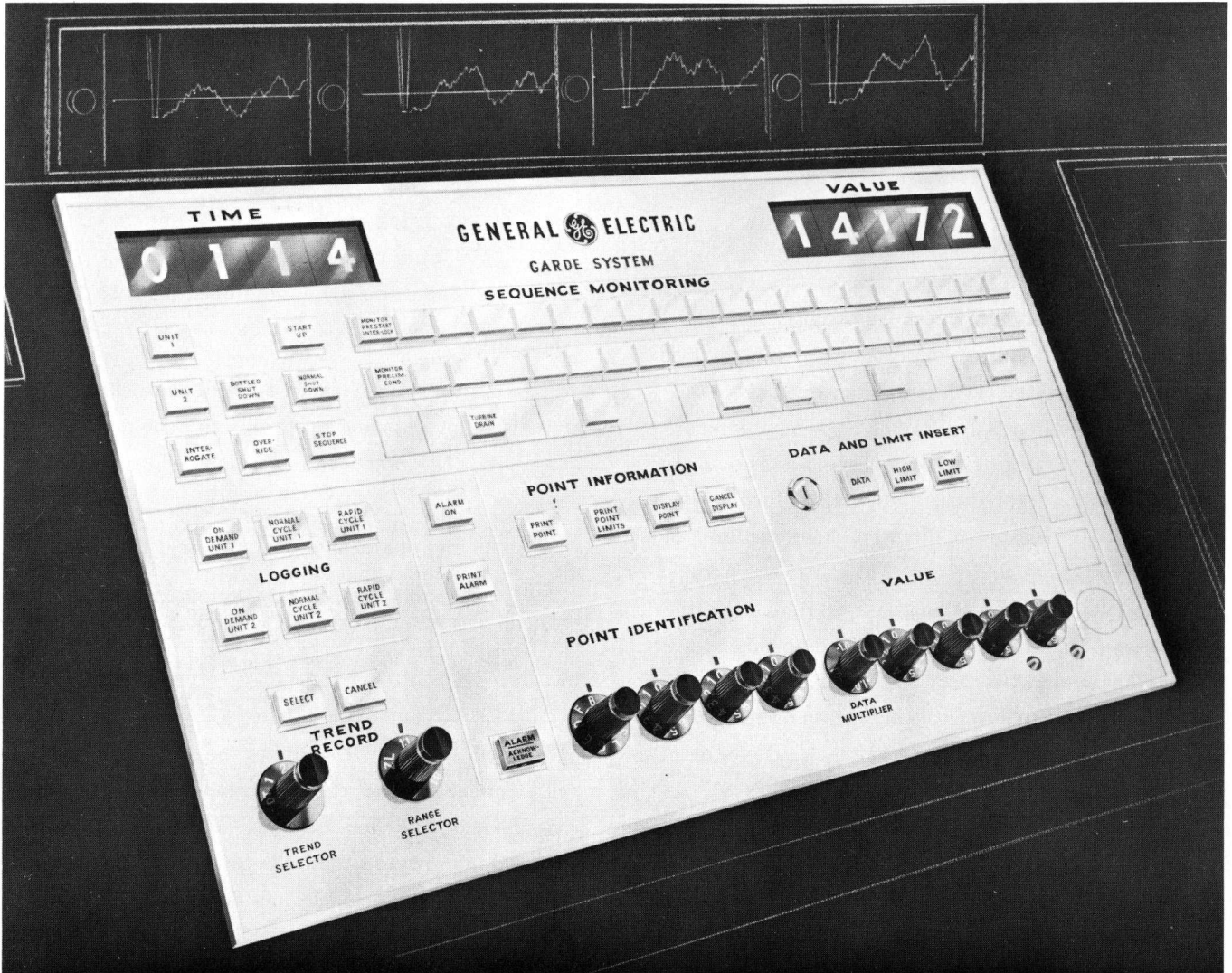

Figure 5. Operator's Control Panel for the GARDE System



Figure 6. Console, Typewriter, Paper Tape Punch and Paper Tape Reader Make Up the GARDE System's Program Control Section.

construction and gasketed doors.

Ease of maintenance is important in a process computer; easy accessibility to all components was a design criterion. The printed-wiring circuit boards and back panel wiring are readily accessible in the cabinet. Overcrowding of components (often necessary in the design of military computers) is avoided. All cabinets containing electronics have an air conditioner to maintain low-level ambient cabinet temperature. This enhances transistor life, eliminating prolonged operation of transistorized circuits at the high temperatures which materially reduce maximum life. Soldering of logic wiring has been replaced by a modern wire-wrap technique which makes positive electrical connections and eliminates failures through cold solder joints.

Computer checking and diagnostic routines quickly detect troubles while the system is in operation. If evidence of a malfunction is discovered, the diagnostic portion of the routine assists in isolating the difficulty and alerts the operator immediately. Normally, the indicated faulty circuits are replaced with spare plug-in boards. Since the number of different types of circuits is small, a minimum spare parts stock is required.

In addition, the ability to disconnect write amplifiers in portions of the memory, so that drum content cannot be accidentally altered, and the non-destructive readout characteristic of the drum memory are positive contributions to the system's high reliability.

Over all System Accuracy

The accuracy of the GARDE System is variable and dependent upon the level of the input signal. The analog channel includes a program-controlled attenuator section and amplifier gain selection providing 16 input signal ranges. A combination of attenuation and gain is selected by the computer program for the particular input point being scanned.

Accuracy for the ranges used with most analog sensors is $\pm 0.15\%$ and repeatability is $\pm 0.07\%$.

Where higher accuracy is required, special procedures are available. For example, the random noise and quantization errors can be reduced by taking several samples of data and averaging them.

For thermocouple inputs, an additional error is associated with the cold junction reference block and the internal system wiring for the thermocouple inputs. This error is $\pm 0.5^\circ\text{F}$ absolute and has a repeatability of $\pm 0.2^\circ\text{F}$. As an example of the effect of this error for a thermocouple input using the 40 millivolt scale, the basic $\pm 0.15\%$ absolute accuracy would become $\pm 0.16\%$ of full scale (assuming temperatures near 1000°F). The basic repeatability of 0.08% is increased to 0.07% of full scale.

If resistance temperature detectors (RTD) were used in place of thermocouples, bridge elements could be selected so that high temperatures could be measured over a selected range to 0.5°F . Similarly, temperature differentials in the order of 30°F could be measured to $\pm 0.1^\circ\text{F}$.

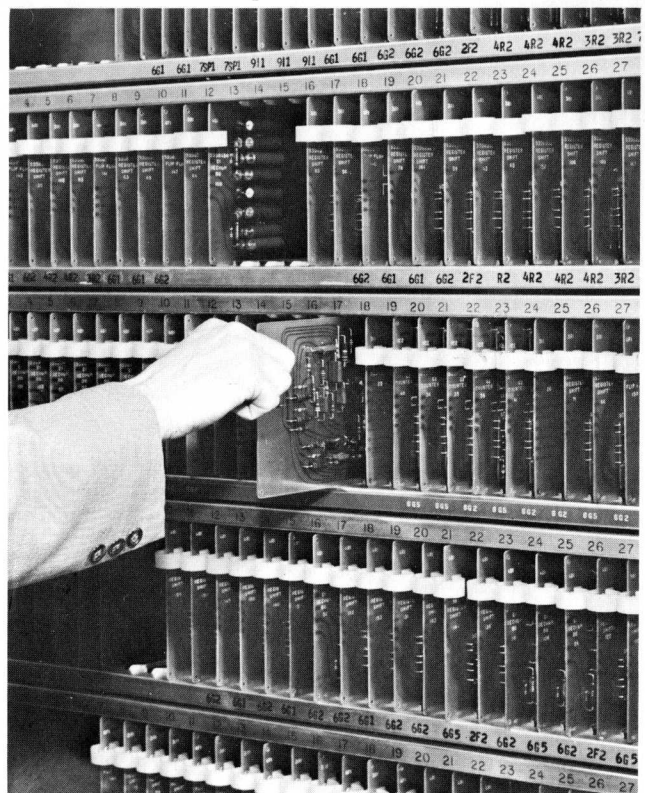

Figure 7. Pull-Out printed Wiring Circuit Boards Facilitate Routine Maintenance

PRINCIPLES OF OPERATION

Computer

The central data processing unit of the GARDE System is the GE 312 Computer. It is a fixed-point, drum memory, digital computer. It uses binary numbers or words up to 20 bits including sign. Fixed point means that the numbers are all considered to have the point (called binary point) just to the left of the first bit position.

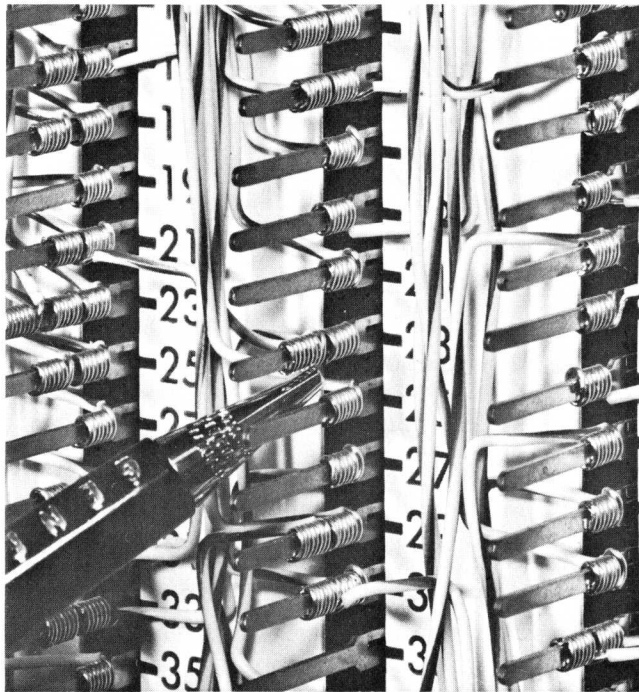

Figure 8. Modern Wire-Wrap Technique Eliminates Failure Because of Cold-Soldered

The computer processes data by means of a program stored on the magnetic drum. For address purposes, the drum periphery is divided into many tracks, each of which is further divided into 128 sectors. Each sector is a storage location for one computer word. The words are either data or instructions. As data, a word is a binary number; but as an instruction, the bit configuration of the word is a code which causes the computer logic to carry out a certain command of the program.

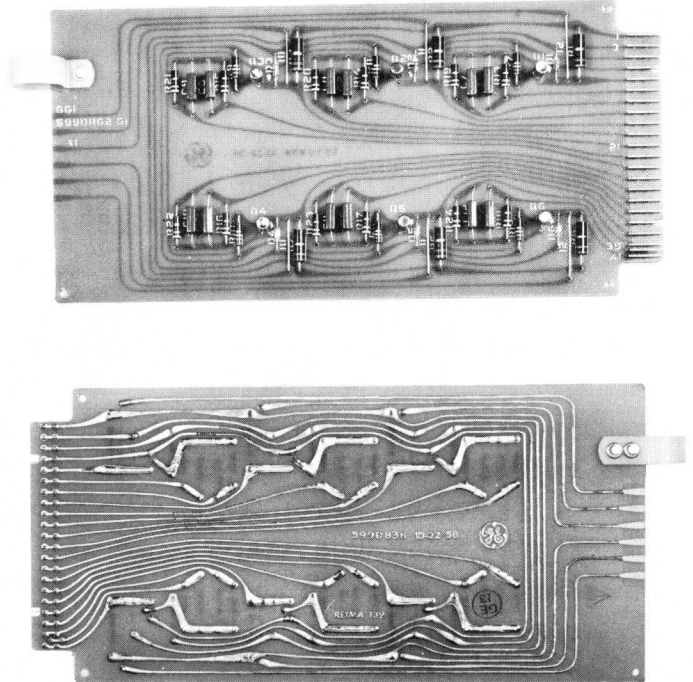

Figure 9. Transistors and Components On Printed Wiring Boards Operate at Fraction of Their Rated Performance



The drum has at least one read-write head associated with each track used. The heads write and read back the "1's" and "0's" making up the computer words. When activated to write, the head causes the magnetic surface at the particular bit location on the drum to be magnetized in one direction for a "1" and in the other for a "0". When directed to read this particular bit, the head senses the difference in the magnetism and transmits the reading, either a "1" or "0", on to the adder. The adder is the main distribution unit within the computer. Information flows through the adder in going to or from the drum. The adder also channels information to the various registers at the direction of computer instructions. Table 1 shows the registers used in the GARDE System, and gives a brief explanation of each.

By logical combinations of bits, the adder performs additions. To add the contents of a word in the A Register to a word in memory, the command ADD is used, causing each of these words to come through the adder, one bit from the drum and one bit from the A Register, at the same time. The resulting sum is channeled back to the A Register. This is the basic arithmetic of the computer, and it is used also for MULTIPLY and DIVIDE by means of special sequencing circuitry. For subtraction, the computer changes the number to be subtracted to the 2's complement form of the binary number and then adds. This produces the same result as direct subtraction.

In addition to the general storage tracks, a scratch pad track is furnished with eight heads spaced at equal distances around the drum. These "trailing heads" allow faster access to data and are used at times to avoid waiting a complete drum revolution for information. Also, a total of four other "trailing heads" are included on other tracks for faster access.

The computer can execute two types of instructions:

Single Address Instruction

This is an instruction which can be executed in one word time and which obtains any data required from the sector on the drum following the sector of the in-

struction. The next instruction to be executed is on the same track in the sector following the data location.

1 + 1 Instruction

This is a type of instruction used when the time for execution is more than one word time, or for which data cannot be located in the sector following the instruction. This type instruction is indicated by presence of a "1" in the 18th bit position of the instruction word. The address of the next instruction (but not the instruction itself for this type command) is located in the drum sector following the instruction word. The address of any data required for a 1 + 1 instruction is specified in the instruction word. In executing this command, the computer loads the instruction into the α Register, then loads the address of the next instruction into the β Register, and searches for the data address contained in the α Register. When the data is located, the command is executed, and the computer then goes to the address contained in the β Register for its next instruction.

Instruction Modification

An instruction modification register in the GE 312 computer simplifies the programming of repetitive routines. Each time the computer goes through the portion of a program where a modified word is used, the address or data is increased by the amount specified in the X Register. This allows using the register for counting, program flow, address modification, and other purposes. Using address modification, a simple routine can take data from a successive location each time through and store results in corresponding successive locations. This saves re-writing the same set of instructions for each time the operation is performed. A word is to be modified when a "1" appears in its 19th bit position. This "1" causes the contents of the X Register to be added to the address portion of the word as it comes from the drum. Use of the X Register is very convenient for program simplification.

| | |
|--------------------------|---|
| A Register | <p>Length = Sign and 19 bits = 20 bits</p> <p>"A" identifies this register with its principal function of <u>accumulation</u> during <u>arithmetic</u> functions. In Division, it holds resulting quotient at completion and most significant half of dividend at the start.</p> |
| Q Register | <p>Length = Sign and 19 bits = 20 bits</p> <p>"Q" identifies this register with its function of increasing the quantity which may be represented for a product, effectively increasing the A Register.</p> <p>In Multiplication, it holds multiplier and least significant half of product.</p> <p>In Division, it holds the least significant half of the dividend and remainder.</p> |
| N Register | <p>Length = 8 bits</p> <p>"N" identifies this register with <u>input</u> from alpha-numeric input units.</p> <p>It acts as a buffer between the computer and the paper tape reader, paper tape punch, and typewriter.</p> |
| X Register | <p>Length = 11 bits</p> <p>"X" is used to identify this register with its function of <u>instruction modification</u>. The presence of a 1 in the 19th bit of a word coming from the drum indicates that the contents of the X Register will be added to bits 4-17 of the incoming word. The X Register is used for automatic address modification, as a counter, and for program flow control.</p> |
| α Register | <p>Length = 20 bits</p> <p>"α" identifies this register with its function during the <u>first</u> step (load) of Instruction Sequencing. (α is the first in an order of items.)</p> <p>α holds the instructions to be performed by the computer. During Multiplication, it holds the multiplicand. During Division, it holds the divisor.</p> |
| β Register | <p>Length = 14 bits</p> <p>"β" identifies this register because its function during Instruction Sequencing follows the α Register function.</p> <p>β holds the address of the next instruction to be performed during 1 + 1 instructions.</p> |
| I Register | <p>Length = 20 bits</p> <p>"I" identifies this register with <u>input</u> from the Digital Data Accumulator. It acts as a buffer between the computer and the digital accumulator. It also contains the <u>input</u> representing 20 contact closures for the Digital Fast Scan.</p> |
| Digital Scan Register | <p>Length = 5 bits</p> <p>It is used to receive 5 bits from the α Register to specify which 1 out of 5 groups, of 20 contacts each, is to be scanned during input operations when the Digital Fast Scan unit is used.</p> |
| Scanner Command Register | <p>Length = 20 bits</p> <p>Identified as SCR, it receives a complete instruction from A Register for initiating an analog-to-digital (A-to-D) conversion, a digital-to-analog (D-to-A) conversion, or a subcontrol (output control) function. It holds the information in proper format for selecting and conditioning input and output signals.</p> |
| C Register | <p>Length = 12 bits</p> <p>"C" identifies this register as the <u>conversion</u> register. It holds the binary portion of the number in an A-to-D or D-to-A conversion.</p> |

Table 1. GARDE System Registers

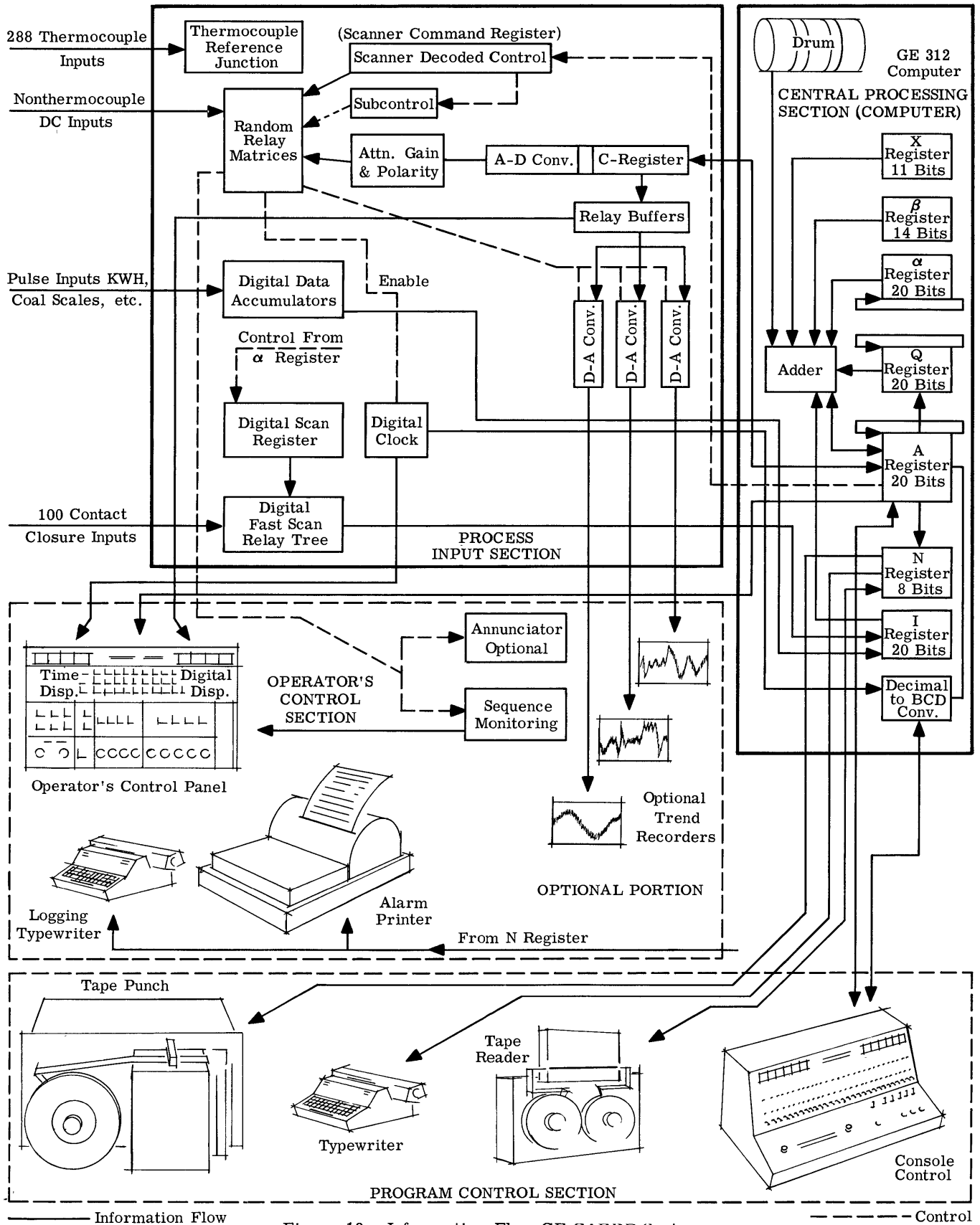

Figure 10. Information Flow GE GARDE System

Information Flow To and From the Computer

The GARDE System information flow paths are shown in Figure 10. All information entering the computer from the process input section passes through the A Register when requested by the computer program. Analog signals come through the analog-to-digital converter and remain in the C Register of the scanner after conversion until transferred to the A Register by instruction. Groups of digital signals selected by the fast digital scan go into the I Register. When requested by the computer program, the group transfers to the A Register. The group can then be compared with a word in memory for determining whether contact status is correct. Pulse inputs stored in the Digital Data Accumulators, upon computer instruction, pass to the I Register. Another command moves the information into the A Register. Inputs from the paper tape reader enter the N Register and in turn are transmitted to the A Register. Data leaving the computer flow from the A Register to the N Register and then to the peripheral devices such as typewriter, punch or printer. Signals generated by the program for selection of lights, alarms, or contact closures flow from the A Register to the Scanner-Distributor. Output signals to the trend recorders flow from the A Register to the C Register and on to a selected "D-to-A" converter board for conversion from digital to analog values.

Data and instructions may be entered into the computer from the program console by manually loading the A Register and transferring that information to other registers. Data and instructions in bulk are normally entered through the paper tape reader.

Operator's Control Section

The steam plant operator receives information from the operator's control panel, the logging typewriter, and the alarm printer. He may also request or insert information, using the controls on the operator's control panel.

The operator's control panel is shown in Figure 5. The time of day is displayed in four digits on the panel from a 24-hour digital clock housed in one of

the input cabinets. For displaying the value of a selected point, the panel also has a five-digit display. A light between the two least significant figures is turned on by the computer if required to indicate the value to one decimal fraction. Sign is indicated by the first position, (-) if minus and blank if plus. Normally, four digits and sign are displayed, but for some calculated values, which are always positive, five digits are shown.

The operator control devices on the panel are push buttons and knobs for point identification and value. The controls to enter limits or data into the computer program are just above the value setting knobs. Since modifying or changing values in the computer program could have a serious effect on the operation of the steam plant, a key is required to activate these push buttons. Information may be requested from the computer by anyone pressing the proper buttons, but only authorized personnel will have a key permitting them to enter information. Any data entered is automatically read from the program and printed out with the time on the alarm printer as a check to insure the proper value was inserted and to give a permanent record of the entry.

To enter information, the operator first turns the key to activate the circuits. He identifies the point and selects the value desired with the appropriate knobs, and then presses the proper push button (HIGH LIMIT, LOW LIMIT, or DATA). The push button remains lighted until the information is entered into the computer program.

Just above the point setting knobs are the controls which permit the operator to request information. Four push buttons (PRINT POINT, PRINT POINT LIMITS, DISPLAY POINT, and STOP DISPLAY) control the display of information about a specific point. The printed information is printed on the alarm printer and the displayed information is on the control panel. When DISPLAY POINT is pressed, the point selected by the operator is continuously displayed and the computer automatically updates the value each time it is scanned or computed. When the

CUSTOMER STEAM STATION UNIT No. _____

| Time | System Check | Unit | | | | | | H. P. Gen. | | | | | L. P. Gen. | | | | | Turbine Steam | | | | | |
|------|--------------|----------------------------------|---------------|---------------------------------|------------------------------------|--------------------------------|--------------------------|------------|-----|------------|--------|-----------|------------|-----|------------|--------|-----------|------------------------------------|-------------------------|-----------------|-----------------------------|------------------|----------------------|
| | | Aux. Load (MW) X10 ⁻¹ | Net Load (MW) | Bus Volt (KV) X10 ⁻¹ | Aux. Trans. (KWH) X10 ³ | Net Gen (KWH) X10 ⁴ | Net Ht. Rt. (B.T.U./KWH) | Field | | | Stator | | Field | | | Stator | | Main Flow (* /HR) X10 ³ | Main Press. (P.S. I.G.) | Main Temp. (°F) | H. P. Exh. Press. P.S. G.L. | R. H. Temp. (°F) | ABS. Press. (IN. HG) |
| | | | | | | | | V | Amp | Temp. (°C) | Amp | Mega Vars | V | Amp | Temp. (°C) | Amp | Mega Vars | | | | | | |
| 1 | 2 | 3 | 4 | 5 | 6 | 7 | 8 | 9 | 10 | 11 | 12 | 13 | 14 | 15 | 16 | 17 | 18 | 19 | 20 | 21 | 22 | 23 | 24 |
| | | | | | | | | | | | | | | | | | | | | | | | |

Graveyard _____ C. O. _____
 Day _____ C. O. _____
 Swing _____ C. O. _____

Date _____

| Condenser | | | Boiler | | | | | F. D. Fans | | | E. Air Preheater | | | | W. Air Preheater | | | | Combustion | | | | Remarks |
|------------------|-------------------|-------------------|--|------------------------------------|---------------------------------|---------------------|--------------------------|------------------------|---------------------------------------|--------------------------------|-------------------|--------------------|-------------------|--------------------|-------------------|--------------------|-------------------|--------------------|---------------------------------|--------------------------------------|---|---|---------|
| Circ. Water | | | Aux. Stm. Flow (#/HR) X10 ³ | F. W. Flow (#/HR) X10 ³ | F. W. HDR. Press. (P. S. I. G.) | Econ. In Temp. (°F) | Div. Wall Out Temp. (°F) | Inlet Temp. (AMB) (°F) | E Disch. Press. (IN-H ₂ O) | W Disch. (IN-H ₂ O) | Air In Temp. (°F) | Air Out Temp. (°F) | Gas In Temp. (°F) | Gas Out Temp. (°F) | Air In Temp. (°F) | Air Out Temp. (°F) | Gas In Temp. (°F) | Gas Out Temp. (°F) | Gas Flow (CFH) X10 ³ | Net Oil Flow (#/HR) X10 ³ | E Flue Gas O ₂ (%) X10 ⁻¹ | W Flue Gas O ₂ (%) X10 ⁻¹ | |
| Inlet Temp. (°F) | E. Out Temp. (°F) | W. Out Temp. (°F) | 28 | 29 | 30 | 31 | 32 | 33 | 34 | 35 | 36 | 37 | 38 | 39 | 40 | 41 | 42 | 43 | 44 | 45 | 46 | 47 | |
| 25 | 26 | 27 | | | | | | | | | | | | | | | | | | | | | |

Figure 11. Typical Log Sheet

button is pressed, the time of day, the value of the point, and its identification is printed out on the alarm printer. This gives a record of the points being displayed. An identifying mark denotes that information on the alarm printer was requested instead of caused by an out-of-limit condition. The display is stopped by pressing the CANCEL DISPLAY button.

The push buttons to the left of the center of the control panel are, top-to-bottom: ALARM ON, PRINT ALARM, and ALARM-ACKNOWLEDGE. The ALARM-ACKNOWLEDGE button is back-lighted by a flashing light when a point is detected outside the limits preset in the computer program. This flickering light is stopped when the operator pushes the button; however, the ALARM ON push button is lighted and remains lighted as long as any value is out of limit.

When the operator pushes the PRINT ALARM button, all points out of limit are printed on the alarm printer. This feature is especially useful to inform an incoming shift operator of all the difficulties which should be corrected.

On the logging module, near the left side of the panel, are push buttons for ON-DEMAND, NORMAL CYCLE, and RAPID CYCLE LOG. For NORMAL CYCLE, the log is automatically typed hourly. If the operator chooses, he may reduce the period between logs by pressing the RAPID CYCLE LOG button. The RAPID CYCLE LOG may normally be desired every 15 minutes; but the period may be altered by changing a constant in the program. The NORMAL CYCLE LOG and RAPID CYCLE LOG buttons are interlocked, so only one can be operated at a time. The operator may request a complete log at any time by pressing the ON-DEMAND button. If the computer detects a malfunction of the logging typewriter, the computer automatically shifts the log to the console typewriter. A typical log sheet is shown in Figure 11.

The value of a point may be recorded once a minute by identifying the point and pressing the SELECT button in the Trend Record Module. If analog trend recorders (option) are included, the Trend Select knob must first be set to DT (Digital Trend).

The Alarm Printer is used not only to automatically inform the operator of alarm conditions but to report many other items as well. A list of the items is shown below. The time of day is printed in all cases and the print is black, except where noted. Table 2 shows the printer code and Table 3 the format for each.

Automatic Printout of Point Identification and Point Value

1. When a value goes out of preset limits - prints red.
2. When a thermocouple opens - prints red.
3. When a value returns within limits.
4. When a data point is selected for display.
5. When data is inserted in program.
6. When limits are inserted in program.
7. When digital trend has been selected - prints once a minute.
8. When the OVERRIDE button has been pressed during start-up or shut-down monitoring (option). Each item not meeting preset requirement is P printed in red.

Automatic Printout of Step Number of Start-up or Shut-down Sequence (Optional)

1. When operation proceeds to next step.
2. When "stop sequence" button is pressed - prints red.

On Demand

1. Point and value of any selected point.
2. Point and limits of any selected point.
3. Trend recorder point, recorder used, scaling factor and chart center value.
4. Point and value of all items preventing advance of sequence in start-up or shut-down monitoring (optional).

Options to Operator's Control Section

The plant operator may be provided with more information to aid him in controlling the unit by the addition of trend recorders, sequence monitoring, and an annunciator panel. The trend recorders and annunciator panel are usually mounted near the operator's control panel. The start-up and shut-down sequence display lights are made an integral part of the panel.

Alarm Printer Code - 10 Positions

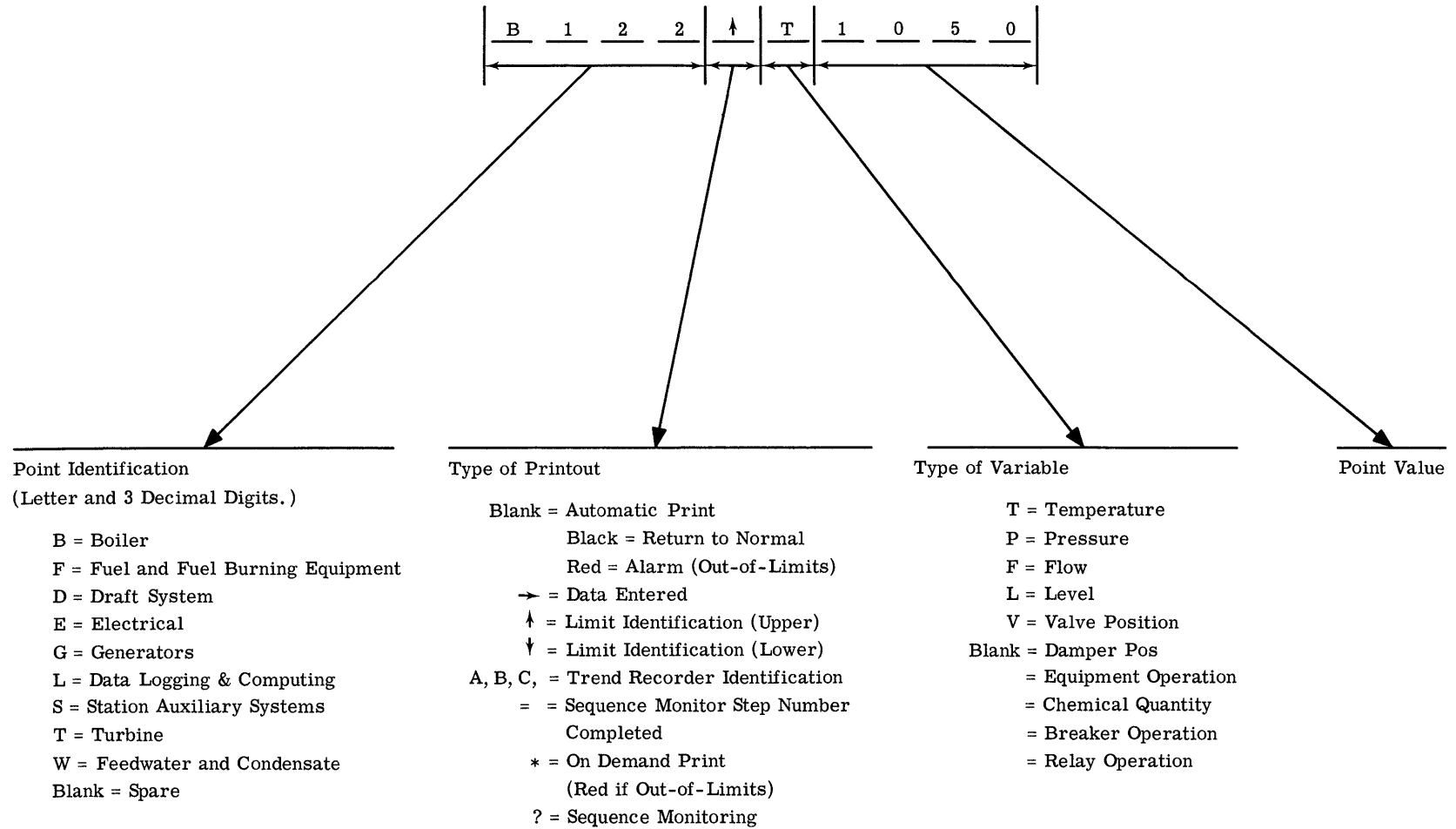

Table 2. Alarm Printer Code

| | | | | | | | | | | |
|---|----------|---|----------|----------|--------------|-----------------------------|--|----------|----------|----------|
| <u>Out-of-Limits</u> | | <u>2</u> | <u>1</u> | <u>1</u> | <u>0</u> | | | | | |
| | | Time | | | | | | | | |
| (Red) | <u>W</u> | <u>1</u> | <u>0</u> | <u>2</u> | <u>T</u> | <u>0</u> | <u>2</u> | <u>1</u> | <u>8</u> | |
| | | Point ID | | | Blank Type | | Value | | | |
| <u>Open Thermocouple</u> | | Same as Out-of-Limit, Except Value All Zeros. | | | | | | | | |
| (Red) | | | | | | <u>1</u> | <u>9</u> | <u>2</u> | <u>2</u> | |
| | | | | | | Time | | | | |
| <u>Point "On Demand"</u> | <u>G</u> | | <u>5</u> | <u>2</u> | <u>*</u> | <u>L</u> | | <u>1</u> | <u>2</u> | <u>5</u> |
| or | | | | | | | | Value | | |
| <u>Digital Trend</u> | | Point | | | Type | | Value | | | |
| | | | | | | | | | | |
| <u>Limit</u> | | | | | | <u>1</u> | <u>3</u> | <u>2</u> | <u>4</u> | |
| | | | | | | Time | | | | |
| | <u>B</u> | <u>1</u> | <u>2</u> | <u>2</u> | <u>↑</u> | <u>P</u> | <u>1</u> | <u>4</u> | <u>6</u> | <u>5</u> |
| | | Point | | | (Upper) Type | | Value | | | |
| | | | | | | | | | | |
| <u>Trend Record</u> | | | | | | | <u>6</u> | <u>1</u> | <u>5</u> | |
| | | | | | | Time | | | | |
| | <u>T</u> | <u>1</u> | <u>2</u> | <u>8</u> | <u>A</u> | <u>P</u> | <u>1</u> | <u>2</u> | <u>5</u> | |
| | | Point | | | Recorder A | | Engr. Units Per Chart Space | | | |
| | | | | | | | <u>6</u> | <u>2</u> | <u>5</u> | <u>0</u> |
| | | | | | | Center of Chart Engr. Units | | | | |
| | | | | | | | | | | |
| <u>Sequence Monitor</u> | | | | | | <u>2</u> | <u>3</u> | <u>5</u> | <u>9</u> | |
| | | | | | | Time | | | | |
| Black = "Interrogate" | <u>1</u> | | <u>2</u> | <u>2</u> | <u>?</u> | <u>V</u> | <u>0</u> | <u>0</u> | <u>0</u> | <u>1</u> |
| Red = "Override" | | Point | | | | Type | Value | | | |
| | | | | | | | (Or Valve Open or Closed. Zero in Last Digit Shows Open) | | | |
| | | | | | | | | | | |
| <u>Sequence Monitor</u> | | <u>1</u> | <u>8</u> | | <u>?</u> | | <u>1</u> | <u>5</u> | <u>3</u> | <u>3</u> |
| | | Step No. 1 - 20 | | | | | Time | | | |
| Black = Print of Completed Step Number When Advancing to Next Step. | | | | | | | | | | |
| Red = Print Number of Last Step Completed at "Stop Sequence." | | | | | | | | | | |

Table 3. Alarm Printing Formats

Trend recorders, a recommended option, may be added if a plot is desired of specific points. Normally three miniature, single pen recorders are furnished with this option, and the operator may select from his control panel the value (computed or simple process variable) to be displayed on each. He merely sets the identification, trend select, and range select knobs and presses the SELECT button. The trend recorder will begin recording the point continuously until the CANCEL button is pressed. When the SELECT button is pressed, the alarm printer automatically records the time, point identification, recorder used, scaling factor, and chart center value. If the trend record is to become a permanent record, the operator writes the information directly on the chart paper. The operator may also request an identification print out of all points being recorded at any time by setting the Trend Select knob to PA (Print Address) and pressing the SELECT button. The printer then records in order the same information listed above for all the recorders

The range select for the trend recorder is a novel and powerful feature. When it is placed to ZL (Zero Left), the trend recorder range is from zero (on the left) to the maximum value obtained (on the right). When the point is set up with 1 : 1 on the range select knob, the initial value is mid-scale on the chart. This permits maximum utilization of the chart. The mid-scale value in engineering units is printed automatically on the alarm printer so the operator knows the value. The scale factor of engineering units per chart line is the same as for zero left operation. The operator may receive much greater resolution by selecting one of the larger ranges. For example, at 8 : 1, the pen is centered at the beginning as before; but now the pen travels 8 lines for the same change which caused it to travel only 1 line on 1 : 1 operation. If the pen goes off the chart, it is easily centered again by repeating the select procedure. A lower range could then be

selected if necessary.

The Unit Operation Guide, another recommended option, consists of the programs and equipment required for monitoring of start-up and shut-down, and guide programs for boiler warmup, turbine acceleration and generator loading. Sequence monitoring is displayed by two rows of 20 backlighted indicators; one row for SHUT-DOWN and one for START-UP. Each window has a custom printed name for its particular step in the sequence. These are used to provide go-ahead signals to the operator at certain points during a unit start-up or shut-down sequence. A lighted window indicates conditions are suitable for going to the next step in the procedure. Monitoring is activated by the START-UP and SHUT-DOWN push buttons. Normally, the windows light in sequence as the operator proceeds through the start-up or shut-down, with the computer initiating alarms whenever preset conditions are not met or something is done in incorrect order.

Buttons are provided so the operator can, at the proper time in a sequence, initiate one of the guide programs, boiler warmup, turbine acceleration, or generator loading. He presses the proper buttons as he begins the operation and is alerted if he exceeds preset rates.

An OVERRIDE button may be pressed if the operator chooses to continue a sequence even though warned that conditions are not precisely as set in the computer program. The alarm printer prints out in red the point and value for all items not meeting predetermined requirements for the step. An "INTERROGATE" button allows the operator to obtain a printout of all items preventing advance to another step in the sequence. Also a button "STOP SEQUENCE" allows the operator to inform the computer that the sequence is being discontinued for the present.

The optional annunciator panel gives alarm information, as does the alarm printer; but has the ad-

vantage of calling immediate attention by equipment or function name to a specific trouble. The annunciator panel windows may be custom marked with information pertinent to the alarm condition. Since an annunciator used with a computer requires output signals from the computer, this option may require an additional relay matrix in the Process Input Section, depending on the number of indicators needed or points already used. An advantage of an annunciator controlled from the computer is that the limits for causing an annunciator point to alarm can be changed within the computer.

Process Input Section

The equipment in the process input section operates under program control by the computer in selecting and conditioning input signals. The three types of input signals are analog, contact, and pulses.

Analog Signals

Analog signals are selected and processed one at a time in the order dictated by the program. Information required for the selection and conditioning of a particular analog input point is programmed into a single computer word of 19 bits called the control word. The configuration of the binary "1's" and "0's" in the control word contains the point address in the relay matrix of the scanner-distributor, the attenuation and gain settings for scaling high or low level indication, and the polarity. At the command, "Load Scanner Control Register" (LSC), the computer transfers the control word, which previously was loaded into the A Register from memory, into the "Scanner Control Register" (SCR).

The decoding circuits associated with the SCR inspect each bit position of the control word. Other logic circuitry in the input equipment carries out the functions directed by the bit pattern as follows:

1. Selects the proper 2-wire analog input through the relay matrix coordinates given.
2. Sets the attenuation.
3. Sets amplifier gain.

4. Sets polarity switch
5. Opens or closes isolation switch as determined by high or low level indicator of control word.
6. Performs analog to digital conversion.
7. Sets operation complete signal.

The computer continues processing data after transferring the control word to the SCR but the program causes it to check the operation complete signal occasionally. When it finds this signal is set, the computer, by program instruction, transfers the completed analog-to-digital conversion held in the C Register into the A Register. The value of the point scanned thus enters the program as needed and is processed or stored, depending on how the program is written.

Contact Closures

Contact closures are sampled in groups of 20 in the order specified by the program. This procedure is called "Digital Fast Scan" in which 100 contacts, on breakers, level alarms, overspeed switches, etc., are checked every second. A particular group of 20 to be checked is selected by the address portion of the command word "Select Digital Scan" (SDS). This portion, the address of the contact group, is transferred from the α Register of the computer to the Digital Scan Register. The Digital Scan Register then automatically energizes the appropriate relay coils of the Fast Scan Relay Tree which close internal contacts, creating an electrical path to each of the set of 20 contacts in the plant equipment. Voltage is applied, causing current to flow in those circuits having closed external contacts. Each of 20 return lines from the external contacts is associated with a corresponding bit position of the I Register. The currents in these lines determine the configuration of "1's" and "0's" in the I Register, a pattern showing which external contacts are closed. At the command, "Compare Y and I" (CYI), the scan output is compared to a correct pattern stored in the computer memory. Any disagreement initiates an alarm printout routine that warns the operator of

contact(s) out of the desired position. The stored pattern may be easily changed or modified if the desired plant equipment status changes.

Pulse Signals

The GARDE System efficiently receives pulse signals from sensors such as KWH meters where each pulse represents a given number of kilowatt-hours delivered. If the sensor sends signals at a fast rate compared to the scan cycle, the sensor is connected directly to a four binary bit counter which temporarily accumulates the counts independently of the computer. The accumulated counts are then transferred sequentially into the computer at time intervals predetermined to prevent the counter from overflowing.

The computer program uses the instructions "Set Input Command" (SIC) and "Input-Add" (ADI) to transfer the contents of an accumulator into the I Register of the computer. The contents of the I Register are then transferred serially to the computer's adder where summation takes place to update the previously stored "old" total. The counter is set to zero and the new sum is returned to memory to complete the routine.

Program Control Section

The Program Control Section consists of the computer console, an electric typewriter, a paper tape punch, and a paper tape reader. This section requires a person trained in programming the GE 312 Computer to operate it.

The computer console provides:

1. The power-on, power-off control for the system.
2. Visual indication of selected registers for monitoring computer activity.
3. Manual input of instructions into registers and memory.
4. A means of stopping the program.
5. Manual execution of the program, single step.
6. System protection indicators which alarm if the program is not functioning properly or the computer is overheating.

The console electric typewriter has a 20" carriage and prints alphanumeric at a maximum rate of ten characters a second. Each character is transferred to the typewriter from the N Register under program control. It is principally used for diagnostic routines; but it also serves as a spare to the logging typewriter and automatically prints the log if the computer detects a logging typewriter malfunction.

The paper tape punch punches at a rate of 20 characters a second. Each character is transferred from the N Register under program control in the standard eight-channel code. The punch may be used to receive a program dump from the computer memory so that it may be preserved and reinserted at a later date. The punch also can receive and record on paper tape process or computed information from the computer. It can be slaved to the typewriter to record all information the typewriter receives; however, the punch will then operate at the same speed as the typewriter. The paper tape punch may be useful to prepare a tape for use in another data processing system.

The paper tape reader reads an eight-channel paper tape at the rate of 20 characters a second. It is principally used to enter large quantities of information into the computer. Each character is entered under program control through the N Register.

High speed paper tape readers and paper tape punches are offered as options to the GARDE System.

Programming and System Checking

The programs as listed under GARDE System Material and Services form an integrated set which will be stored in the computer memory. They are coordinated for proper timing relationships and memory assignment. The programs are shown in Figure 12.

Each individual program is written as a separate module or subprogram with its own entrance and exit. Use of functional program modules allows flexibility in arranging the order of the overall pro-

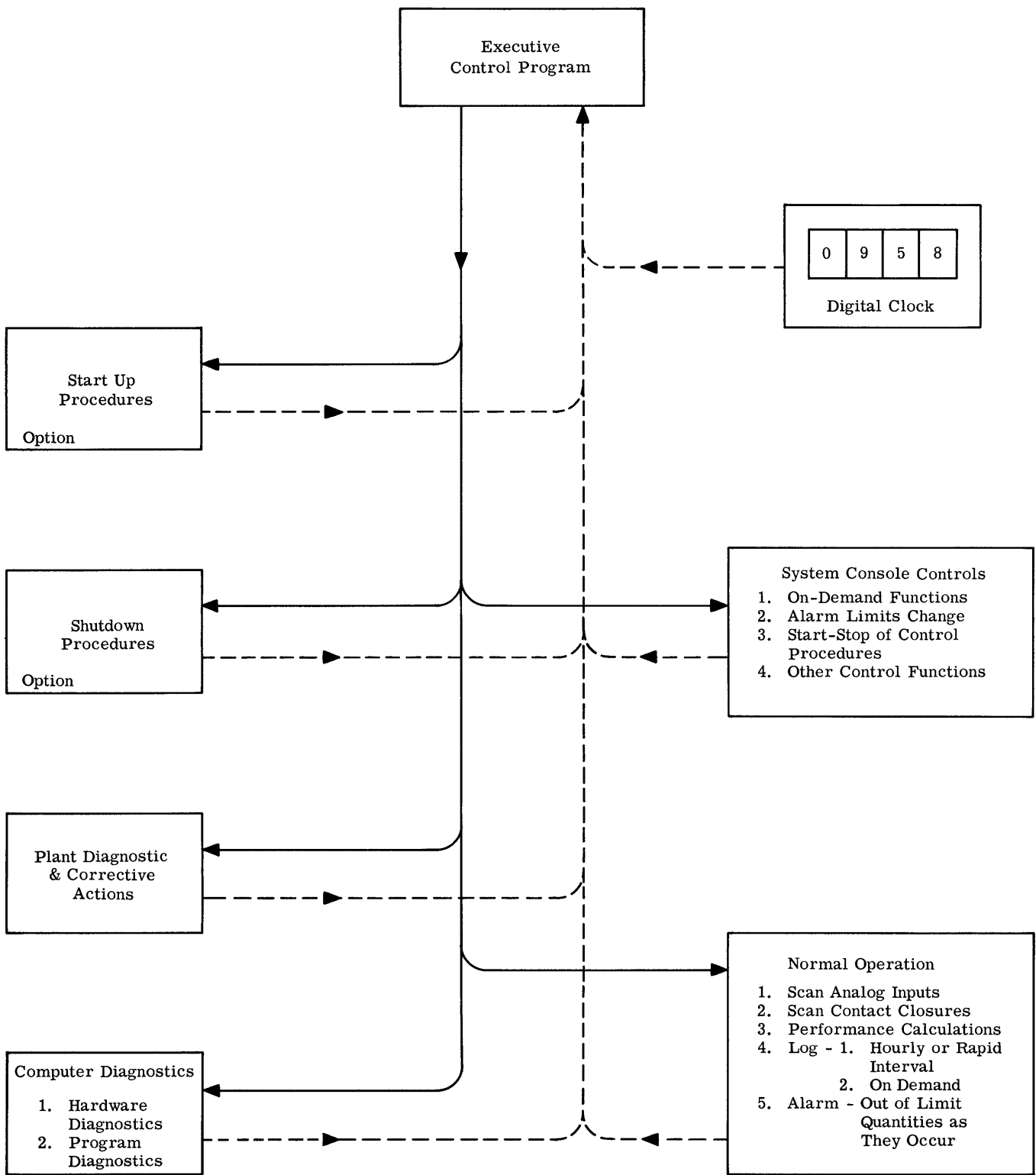

Figure 12. Overall Program Flow

gram. Since a real-time process computer must work on the most important job at hand just as a plant operator would, separation of programs by functions is required.

Executive Program

The Executive Control Program (ECP) assigns priorities to the individual subprograms. It coordinates on a real-time basis all computer functions. Each time the computer completes an assignment, it returns to the Executive Control Program for instructions as to which program should be entered next. Sequence procedures, normal scanning operations, logging, system diagnosis, etc., will all be coordinated with respect to real-time and priorities. Obviously, alarm will have higher priority than hourly logging or computer checking and diagnostic programs. The ECP assigns the computer to its tasks on the basis of urgency. A suggested priority assignment of programs is:

1. Scan input points as required for alarm and system operation.
2. Alarm print-out.
3. On-demand print-out of an analog quantity.
4. On-demand log.
5. Trend recordings.
6. Alarm limit change.
7. Performance calculation.
8. Logging.
9. Periodic computer diagnostics and checking.

The ECP also makes assignments on the basis of the time of day. This insures that regularly scheduled functions, such as the hourly log, are accomplished.

Normal Operation

Scanning, alarming, and logging are interrelated functions. Normally, the computer scans each point according to a prescribed sequence and frequency. Each point scanned is compared against the high/low limits stored in memory for alarm purposes. The operator can change limits as required through controls on the operator's control panel. If any point is

out of limit, the computer will initiate the alarm print-out, or annunciate the alarm. Continuous scanning proceeds at all times and is not interrupted when there is an on-demand log required or when it is time for the regular periodic log. When an on-demand log is requested, or when the time has arrived for a regular periodic log, the computer will perform the necessary calculations from the most recent set of scanned data or from averaged data as required.

Guiding and Monitoring of Start-Up and Shut-Down Procedures - Recommended Option

The function of monitoring start-up and shut-down, the Unit Operation Guide Option to the standard GARDE System, involves checking and guiding the manual control operations performed by the plant operator during the various start-up and shut-down procedures associated with operating the boiler-turbine-generator unit. The GARDE System can provide this function by checking the actual manual operation against the correct sequences stored in memory. The monitoring function can be divided into three phases:

1. Identifying for the operator the next step in the sequence, or identifying by print-outs a portion of a previous sequence omitted.
2. Checking the rates of boiler warm-up, turbine acceleration and generator loading, and guiding the operator in correcting excessive deviation from acceptable rates.
3. Monitoring the manual control operations, and indicating by alarms any misoperation or out-of-sequence operation.

Information for the monitoring function is provided for the operator by backlighted nameplates for each step on the operator's control panel for the monitored control sequences, and pushbuttons for initiating check of rates of boiler warm-up, turbine acceleration and generator loading. Alarm print-out will identify any incorrect operation.

Performance Calculations

Performance calculations provide accurate and meaningful information on performance to guide system

and plant operation. The list of performance calculations is as follows:

1. Boiler efficiency
2. Overall station heat rate (Boiler-Turbine-Generator)
3. Turbine-Generator heat rate
4. Correction of heat rates to reference conditions
5. High pressure and intermediate pressures turbine efficiency
6. Feedwater heater and other heat exchangers
7. Condenser performance

The calculations are usually done hourly using averaged data. The calculations can be based on short-time data to provide an on-demand check of performance or for a trend logging of performance.

Allocation of Computer Time

During start-up of the boiler-turbine-generator unit, the various portions of the scanning programs are initiated so that the necessary inputs are scanned as required. When the start-up is complete and the unit is on the line in normal operation, all portions of the scanning programs will be in use; that is, the computer will scan all inputs at the established rates. When the unit is operating normally, the computer is dividing its time between scanning and processing data, and doing performance calculations. Certain critical inputs are scanned more frequently than others, but practically all are scanned at least every minute. During processing the computer can obtain by random access any data it requires from any of the inputs.

GARDE System Service Routines

The GE 312 computer service routines are supplied with the GARDE System package in symbolic form. They are routines used in maintenance of the computer or for loading or unloading computer memory.

1. Selective Memory Dump
This is a program to unload the contents of

selected locations of the drum storage on punched paper tape or the typewriter. The entire dump routine must be on the drum before the unloading can take place.

2. Selective Trace
This is a program to trace a portion of a program without going through the whole program. The output will be reproduced on the typewriter or paper tape punch.
3. Decimal-to-Binary Input Conversion
This subroutine converts decimal numbers punched on paper tape to binary numbers to be used internally in the machine.
4. Binary-to-Decimal Output Conversion
This subroutine converts a binary number to decimal and types it on the typewriter.
5. Paper Tape Loader
This subroutine when placed in computer memory is used to load the program or other information into memory using the paper tape reader.

GE 312 Diagnostic Routines

This is a set of subroutines to be used with a control program to check the GE 312 computer for certain malfunctions and to provide an indication of the malfunction. The routines include testing the following:

1. The A Register and all instructions connected with, and only with the A Register.
2. The Q Register and all instructions connected with the Q Register and the combination of the A and Q Registers.
3. The N Register and all instructions connected with the N Register and with the different combinations of the A, Q, and N Registers.
4. The X Register and all instructions connected with the X Register and the different combinations of the A, Q, and X Registers.

5. The Multiply Instruction (MPY).
6. The Divide Instruction (DVD) including the overflow indication.
7. The Input-Output Test. This tests the typewriter, the reader, and the punch. A table of all legal output characters is typed and punched. A tape is read by the reader and compared to the stored table.

These routines aid in the location of computer malfunctions both during the system operation and in off-line testing. If the stored diagnostic program detects a malfunction during system operation, the program branches into a loop to cause the stall alarm to be actuated. The program stores specific information concerning the type of error detected which assists in location of the malfunction.

GE 312 Computer Checking Features

The GE 312 Computer has the following check features:

1. Parity Check - An extra bit added to each word going on the drum following the 20th bit is the parity bit. If the total number of "1's" in the word is an even number, the parity bit is "1". If the total is odd, the parity bit is "0". This is called "odd" parity. The bit following the last bit is checked for parity as the word is read from the drum and if incorrect, a parity error indicator on the console is lighted. The program checks the parity error indicator frequently to alert the operator if parity errors occur and continue. A parity stop switch on the computer console can also be set to stop the computer sequencing if a parity error occurs.
2. Stall Alarm - The stall alarm indicator on the computer console will be lighted if a malfunction causes the computer to enter a continuous loop such that it cannot perform its other routine functions.



GARDE SYSTEM MATERIAL AND SERVICES

The basic GARDE System consists of the equipment, programs, and services listed below.

Equipment

1. The GE 312 Computer (Model 4WC312C1) consisting of:
 - A 24,000 word drum memory,
 - Trailing-head package for fast access memory,
 - Built-in air conditioning.
2. Computer console
3. In association with computer console:
 - One 20" electric alphabetic-numeric type-writer (Model 4WVB312A1) which will serve as on-line spare to logging type-writer,
 - One eight-channel, 20 characters/sec., paper tape reader (Model 4WFA312A1);
 - One 20 characters/sec., paper tape punch (Model 4WGA312A1);
 - One table for mounting the program control equipment.
4. Operator's control panel (Model 4WKB312A1).
5. One 20" electric numeric logging type-writer (Model 4WVB312A1).
6. One serial alarm printer (Model 4WPA312A1) with on-line spare.
7. Process input section consisting of:
 - Scanner/Distributor (Model 4WSA312A1), with capacity for 370 analog inputs,
 - Digital fast scan (Model 4WSB312A1) for scanning of 100 contact inputs every second,
 - Digital Data Accumulator (Model 4WJA312A1) for 8 pulse inputs,
 - Thermocouple reference for 288 thermocouple inputs,

Equipment for open thermocouple detection;

A balanced computer controlled attenuator and amplifier section which permits automatic range selection of 16 ranges from 10 mv dc full scale to 256 v dc full scale;

An analog-to-digital converter;
 Digital clock (Model 4WRA312A1),
 Built-in air conditioning where required.

Programs

The GARDE System is complete with all programs ready to operate.

1. Executive control program directing the use of all other programs on a pre-assigned priority basis. Some of the functions listed below are segmented into many parts to facilitate proper cycling.
2. Continuous scan.
3. Alarm print routine.
4. Periodic logging.
5. On-demand log.
6. Twenty-four hour summary log.
7. Performance calculations
 - Boiler efficiency;
 - Turbine-generator heat rate;
 - Station heat rate,
 - Correction of heat rates to reference conditions,
 - High and intermediate pressure turbine efficiency;
 - Condenser performance;
 - Feedwater heater and other heat exchanger equipment performance.
8. Other calculations, such as meter calibrating, input averaging, input rate of change, and input integrating.
9. Computer diagnostic and checking.
10. System diagnostic and checking.

11. Operator's control panel read-in.
12. Service routines, such as selective memory dump, selective trace, decimal-to-binary conversion, binary-to-decimal conversion, and paper tape load.
13. Other sub-routines are available and may be included at no additional cost in many cases.

Services

1. Factory training courses:
 - Programming course -
 - Basic programming - 1 week,
 - GARDE System programming - 2 weeks,
 - Customer specific applications - 2 weeks.
 - Maintenance course - 7 weeks.
2. Installation service - Supervision of installation and initial operation to insure proper operation of system.
3. Manuals
 - Three sets, including:
 - Programming,
 - System,
 - Service and Maintenance;
 - Instruction Manual.
4. Factory test - 24 hour continuous run which includes simulated inputs and power interruptions.
5. On-site consultation for specification definition.
6. Field application engineers for on-site consultation, instruction, and programming assistance. These representatives are placed locally to provide quick assistance at any time during the life of the system.

Options

The basic GARDE System may be expanded at the factory or after installation as follows:

1. Central computer memory size expansion

up to 54,000 words.

2. Process input section expansion:
 - Up to an additional 380 analog inputs,
 - Up to 540 additional contact closures,
 - Up to 8 additional pulse accumulators;
 - Up to a total of 430 thermocouple reference junctions,
 - Transducers to convert analog signals to dc voltages.
3. Additional electric logging typewriters.
4. Optional column printer.
5. High-speed paper tape reader (Model 4WFB312A1) 60 characters/sec. max., 40 characters/sec. nominal.
6. High-speed paper tape punch (Model 4WGB312A1) 60 characters/sec. max., 40 characters/sec. nominal.
7. Equipment and programming to provide trend record of sensed or computed data (Recommended option).
8. Annunciator panel, 40 or 96 window.
9. Unit Operation Guide, including Sequence Monitoring Panel (Recommended Option) and programs.
10. Standby power supply when main power fails.
11. Additional cabinets for additions to system.
12. Log paper and printing plates specifically designed for purchaser's requirements.
13. Custom modifications or additions to system.
14. Expert assistance in:
 - System analysis;
 - Pre-installation input checkout,
 - Programming,
 - Coding.
15. Contract maintenance by factory-trained specialists.

SPECIFICATION SUMMARY FOR THE GE GARDE UTILITY SYSTEM

Process Inputs

Analog inputs: Up to 370, optional to 750.

Input signals: Bipolar to 256 volts dc. Sixteen ranges from 10 mv full scale to 256 volts full scale assure accurate resolution of the signal. Transducers can be supplied to convert other analog signals to dc. Reference junction for 288 thermocouples are provided.

Contact closures: Up to 100; optional to 640.

Pulse signals to be accumulated:
Up to 8, optional to 16.

Scan cycle: One minute. Effective analog scan rate is 8 points/sec.

Scanner: Mercury wetted relay matrix. Each input is individually and randomly addressable by the computer program.

Computer

Model Number: GE 312

Number system: Binary, fixed point. Word length is 19 binary digits plus one sign bit. Handles decimal numbers, alphabets, and special symbols.

Instruction system: Single address and one-plus-one address. This unique feature greatly improves programming efficiency, allowing the advantages of both systems.

Basic commands. More than 80.

Instruction highlights: Twelve branch commands are provided, including branches on accumulator odd, overflow, plus, minus, zero, X register high, X register low, and unconditional. An eleven-bit automatic modification of instruction address is provided for such uses as automatic instruction modification, linkage for sub-routines, and counters. All commands, including shift commands, are executed in one word-time except Multiply, Divide and Store (exclusive of drum access and instruction loading).

Memory Unit: Magnetic drum with 24,000 words of storage capacity. Drum speed is 4800 rpm which gives an average access time of 6.25 ms for general storage. Eleven trailing heads are included to provide fast access storage. Fast access track with 7 of these trailing heads provides an average access time of 0.780 ms.

Speed (time to read instructions, data, and execute with optimum storage location):

| <u>Operation</u> | <u>Word Time</u> |
|------------------|------------------|
| Add or subtract | 2 |
| Multiply | 22 |
| Divide | 27 |
| Branch | 2 |
| Load | 2 |
| Store | 4 |
| Word transfer | 2 |

Digital Input/Output

Paper Tape Reader: Standard 20 characters/sec. Optional readers with speeds up to 60 characters/sec.

Paper Tape Punch: Standard 20 characters/sec. Optional punch with speeds up to 60 characters/sec.

Electric logging typewriter: 20" carriage, 10 characters per second.

Electric console typewriter: 20" carriage, 10 characters per second. May be used as on-line spare for logging typewriter.

Alarm printer: Standard serial printer (with on-line spare), one line of 10 characters per sec. Optional high speed column printer.

Computer Console

Controls with indicator lights: Power on, power off, program start, program stop, single stop.

Indicator lights: Standby and warning. Register and flip-flop state indicators.

Controls: 20 program data insert switches, circuit and register selector, and transfer switches.

Operator's Control Panel

Visual display: Digital clock and data display of 4 digits plus sign for analog input point, or 5 digits for computed value.

Panel switches:

Data select - 4 decimal rotor switches;
Data multiplier - 1 rotary switch;
Point select - 4 decimal rotary switches,
Alarm indicator and acknowledge button;
Alarm-on button,
Alarm print out button;
Button and key switch section for data entry functions;
Four button section for point information retrieval;
Six button section for logging instructions (3 per unit);
Optional two button and two rotary switches for trend recorder selection;
Optional Sequence Monitoring Panel with 40 lighted indicators and 14 pushbuttons.

System Accuracy

Accuracy on ranges of most plant sensors is 0.15% of full scale and repeatability of 0.07% of full scale.

General Characteristics

Size: Computer cabinets (three) - 76 inches high, 105 inches long, 26 inches deep. Input-output cabinets (four) - 76 inches high, 140 inches long, 26 inches deep.

Weight: Approximately 7000 pounds.

Air conditioning: Self contained. Maximum ambient temperature 105F with 95% relative humidity. The minimum ambient temperature is 68F.

Power requirement: 12KW maximum including outlets and air conditioning, 115/230 volts \pm 10%, 60 cps \pm 1%.

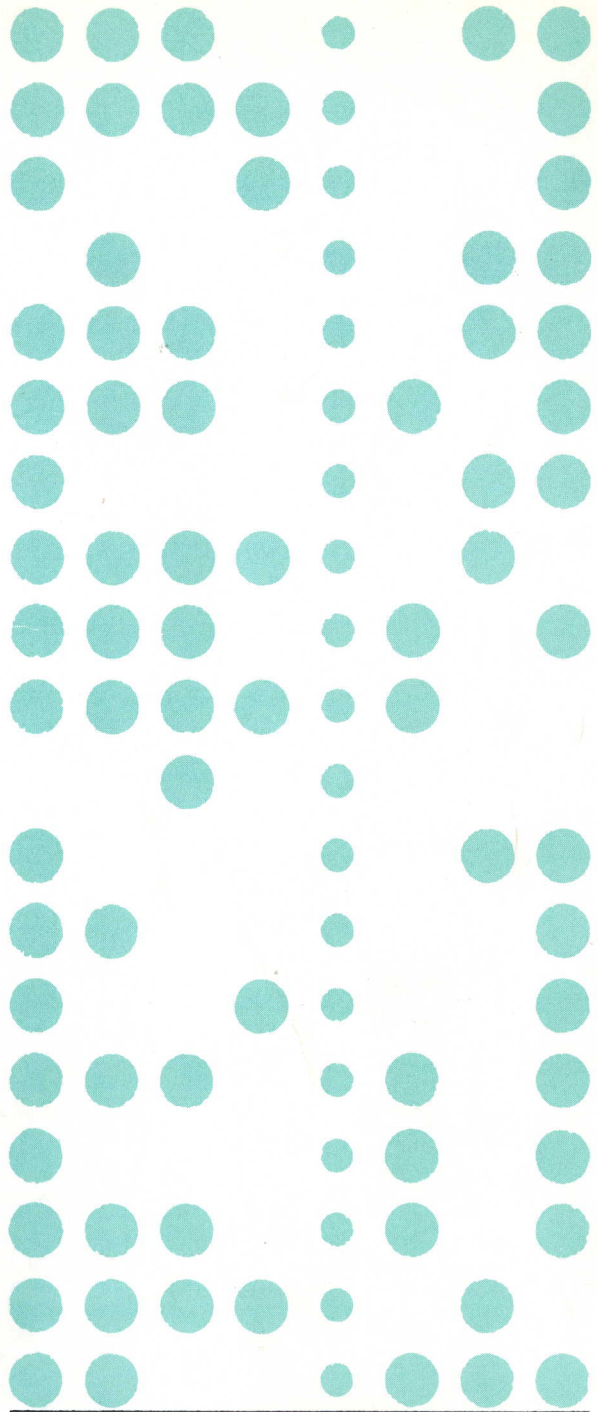

PROCESS COMPUTER SECTION

INDUSTRY CONTROL DEPARTMENT
PHOENIX, ARIZONA

Progress Is Our Most Important Product

GENERAL  ELECTRIC

