

Table of Contents

CHAPTER 1 SYSTEM OVERVIEW	1-1
INTRODUCTION	1-1
MANUAL ORGANIZATION	1-3
SYSTEM DESCRIPTION	1-3
Tasks	1-3
Foreground/Background Tasks	1-3
User/Executive Tasks	1-3
Previously Written 16-bit Programs	1-3
Program Addresses and Logical Segments	1-4
Status	1-4
Protection	1-4
Command Processor Services	1-4
Memory Management	1-5
Foreground Partitions	1-5
Background Partition	1-5
Task Common	1-5
Resident Libraries	1-5
System Space	1-6
Sample Memory Allocation	1-6
Resident Loaders	1-7
Roll Out/Roll In	1-7
Protection	1-7
Task Overlays	1-7
Executive Services	1-7
Interrupts and Traps	1-8
Task Status Word (TSW)	1-8
Task Handled Traps	1-8
Task Queue Service	1-8
Power Restoration	1-8
Interrupts	1-8
Task Priority and Scheduling	1-9
Data Management Services	1-9
Devices	1-9
Direct Access Files	1-9
Volume Organization	1-9
Identification of Files	1-11
File Organization	1-11
Indexed Files	1-11
Contiguous Files	1-12
File Access Methods	1-13
Random Access	1-13
Sequential Access	1-14
File and Device Protection	1-14
Static Protection	1-14
Dynamic Protection	1-14
Write Protection	1-15
Null Device	1-15
CHAPTER 2 TASK MANAGEMENT	2-1
TASKS	2-1
Interrupts and Traps	2-1
Task Status Word (TSW)	2-1
User Dedicated Locations (UDL)	2-2
TASK HANDLED TRAPS	2-4
Task Queue Service Traps	2-4
Power Restoration Traps	2-5
Trap Generating Devices (TGD)	2-5
INTERRUPTS	2-5
Floating Point and Fixed Point Divide Arithmetic Faults	2-5
Illegal Instruction	2-5
Machine Malfunction	2-6
Memory Protect Fault	2-6
TASK STATUS AND OPTIONS	2-6

Table of Contents (Continued)

CHAPTER 3 SUPERVISOR CALLS	3-1
SVC INSTRUCTIONS	3-1
Valid SVC Calls	3-1
SVC Errors	3-2
SVC 1 – INPUT/OUTPUT REQUESTS	3-2
Data Transfer Requests	3-2
Command Function Requests	3-4
Logical Unit (LU)	3-4
Error Status (Device Dependent and Device Independent Status)	3-4
Buffer Address	3-5
Random Address	3-6
Length of Data Transfer	3-6
Unconditional Proceed	3-6
Wait/Proceed I/O	3-6
Wait Only	3-6
Test I/O Complete	3-6
Halt I/O Command	3-7
SVC 2 – GENERAL SERVICE FUNCTIONS	3-7
Code 1 – Pause	3-8
Code 2 – Get Storage	3-8
Code 3 – Release Storage	3-9
Code 4 – Set Status	3-9
Code 5 – Fetch Pointer	3-9
Code 6 – Unpack Binary Number	3-10
Code 7 – Log Message	3-10
Code 8 – Fetch Time	3-11
Code 9 – Fetch Date	3-11
Code 15 – Pack Numeric Data	3-12
Code 16 – Pack File Descriptor	3-12
Code 17 – Mnemonic Table Scan	3-13
Code 18 – Move ASCII Characters	3-14
Code 19 – Peek	3-15
Code 23 – Timer Management	3-15
SVC 3 – END OF TASK (EOT)	3-16
SVC 5 – FETCH OVERLAY	3-16
SVC 6 – INTERTASK COORDINATION	3-17
Task ID and Function Code	3-19
Errors	3-20
Status Return	3-20
End Task Function	3-23
Load Task Function	3-23
Send Message Function	3-23
Queue Parameter Function	3-23
Change Priority Function	3-23
Task Resident and Non-Resident Functions	3-24
Trap Generating Device Functions	3-24
Connect	3-24
Thaw	3-24
SINT	3-24
Freeze	3-24
Unconnect	3-24
Start Task Function	3-25
Sending and Receiving Task Messages	3-25
Message Buffer Structures	3-26
Single-Buffer Ring	3-26
Single-Buffer Chain	3-26
Multiple-Buffer Ring	3-26
Multiple-Buffer Chain	3-26

Table of Contents (Continued)

SVC 7 FILE MANAGEMENT SERVICES	3-28
SVC 7 Parameter Block Fields	3-28
Command (CMD)	3-30
Access Privileges (MOD)	3-30
Buffer Management (MOD)	3-30
Status (STAT)	3-30
LU Field (LU)	3-30
Write Key and Read Key (WKEY,RKEY)	3-30
Logical Record Length (LRECL)	3-31
Volume ID or Device Mnemonic	3-31
Filename	3-31
Extension	3-31
Size	3-31
SVC 7 Functions	3-31
Allocate	3-31
Assign	3-32
Change Access Privileges	3-32
Rename	3-32
Reprotect	3-32
Close	3-33
Delete	3-33
Checkpoint	3-33
Fetch Attributes	3-33
SVC 9 – LOAD TSW	3-35
CHAPTER 4 GUIDE TO USING SVC 2 FACILITIES	4-1
COMMAND PROCESSORS	4-1
COMMAND STATEMENT INPUT	4-1
Mnemonic Scan	4-1
Operand Decoding	4-3
Decimal and Hexadecimal Numbers	4-3
File Descriptors	4-4
Further Mnemonics	4-5
ASCII Strings	4-5
CHAPTER 5 GUIDE TO TASK-HANDLED TRAPS	5-1
INTRODUCTION	5-1
TASK STRUCTURE	5-1
Task Status Word (TSW)	5-1
User Dedicated Locations (UDL)	5-3
Mainline Code	5-5
Task Queue	5-5
Task Trap Service Routines	5-6
Task Queue Service Routine	5-6
Power Restoration Trap Service Routine	5-7
OS/16 MT2 SYMBOLS AND STRUCS	5-8
TASK PREPARATION	5-11
CHAPTER 6 GUIDE TO OS/16 MT2 FILE STRUCTURES	6-1
DEFINITION OF TERMS	6-1
FILE IDENTIFICATION	6-1
FILE PROTECTION	6-2
Static Protection	6-2
Dynamic Protection	6-3
Protection Modification	6-3
Multiple LU Considerations	6-3

Table of Contents (Continued)

ACCESS METHODS	6-4
Random Access	6-4
Sequential Access	6-4
BUFFER MANAGEMENT	6-4
Buffered Logical	6-5
Unbuffered Physical	6-5
FILE STRUCTURES	6-5
Indexed Files	6-6
Contiguous Files	6-7
FILE MANAGEMENT	6-7
Allocation	6-7
Assignment	6-8
Closing	6-8
Deletion	6-8
Checkpointing	6-8
TRADEOFFS	6-8
CONCLUSIONS	6-9/6-10
CHAPTER 7 GUIDE TO USER OVERLAYS	7-1
INTRODUCTION	7-1
ROOT AND OVERLAY SEGMENTS	7-1
OVERLAY CONVENTIONS	7-2
OVERLAY DESIGN CONSIDERATIONS	7-3/7-4
Task Level	7-3/7-4
System Level	7-3/7-4
OVERLAY EXAMPLE	7-3/7-4
CHAPTER 8 INPUT/OUTPUT PROGRAMMING	8-1
INTRODUCTION	8-1
CONTIGUOUS FILES	8-1
INDEXED FILES	8-2
TELETYPE KEYBOARD/PRINTER	8-3
TELETYPE READER/PUNCH	8-4
LOCAL CRT	8-5
HIGH SPEED PAPER TAPE READER/PUNCH	8-6
LINE PRINTER	8-7
CARD READER	8-7
MOVING HEAD DISC	8-8
FLOPPY DISC	8-9
CASSETTE	8-10
9 TRACK MAGNETIC TAPE	8-10
7 TRACK MAGNETIC TAPE	8-11
EIGHT LINE INTERRUPT MODULE	8-12
DIGITAL MULTIPLEXOR	8-13

Table of Contents (Continued)

CHAPTER 9 GUIDE TO WRITING DRIVERS	9-1
INTRODUCTION	9-1
DEVICE CONTROL BLOCK	9-1
Maximum Record Length	9-4
Read/Write Count	9-4
Device Code	9-4
Device Number	9-4
Attributes	9-4
Keys	9-4
A(Busy Flag)	9-4
A(Abort Termination Routine)	9-4
Timeout Count	9-4
Flags	9-4
A(Initialization Routine)	9-5
Old PSW	9-5
New Status	9-5
Register Save Area	9-5
Busy Flag	9-6
DRIVER LOGIC FLOW	9-6
SUPERVISOR CALLS	9-9
EXECUTIVE ROUTINES	9-10
DRIVER INITIALIZE ROUTINE (DIR)	9-10
INTERRUPT SERVICE ROUTINE (ISR)	9-11
I/O TERMINATION	9-11
IODONE	9-12
I/O WAIT	9-12
CANCEL I/O	9-13
HALT I/O	9-13
SAMPLE DRIVER	9-13
SUMMARY OF REGISTER CONVENTIONS	9-15
Registers on Entry to Driver	9-15
Registers on Entry to Executive	9-15
RTOS DRIVER COMPATIBILITY WITH OS/16 MT2	9-16

APPENDICES

APPENDIX 1 SVC SUMMARY	A1-1
APPENDIX 2 CONTROL BLOCK SUMMARY	A2-1
APPENDIX 3 OS/16 MT2 STRUCTS	A3-1

ILLUSTRATIONS

Figure 1-1	OS/16 MT2 System Overview	1-2
Figure 1-2	OS/16 MT2 Memory Map Example	1-6
Figure 1-3	Volume Organization	1-10
Figure 1-4	OS/16 MT2 File Structures	1-12
Figure 2-1	Task Status Word (TSW)	2-2
Figure 2-2	Task Status Halfword	2-3
Figure 2-3	User Dedicated Locations (UDL)	2-3

Table of Contents (Continued)

Figure 3-1	SVC 2 Code 19 Parameter Block	3-15
Figure 3-2	SVC 6 Parameter Block	3-18
Figure 3-3	Message Buffer Structures	3-27
Figure 3-4	SVC 7 Parameter Block	3-28
Figure 3-5	SVC 7 Command/Modifier Halfword	3-29
Figure 5-1	Task Status Word (TSW)	5-2
Figure 5-2	Task Structure	5-4
Figure 5-3	Task Requirement Summary	5-7
Figure 5-4	CAL Source	5-11
Figure 5-5	FORTRAN Source	5-12
Figure 5-6	FORTRAN Source with RTL	5-12
Figure 6-1	Indexed File Structure	6-6
Figure 6-2	Contiguous File Structure	6-7
Figure 7-1	Partition For An Overlaid Task	7-2
Figure 7-2	Establish a Sample Overlaid Task	7-3/7-4
Figure 9-1	Device Control Block Map	9-7
Figure 9-2	Device Control Block	9-3
Figure 9-3	Internal Flow	9-7/9-8
Figure 9-4	SVC 1 Parameter Block	9-9
Figure 9-5	I/O Wait Thread	9-12

TABLES

TABLE 1-1	ACCESS PRIVILEGE COMPATIBILITY	1-15/1-16
TABLE 2-1	TASK QUEUE ENTRY TYPES	2-4
TABLE 2-2	TASK OPTIONS	2-6
TABLE 2-3	TASK STATUS	2-7/2-8
TABLE 3-1	OS/16 MT2 SUPERVISOR CALLS	3-1
TABLE 3-2	SVC 1 DATA TRANSFER FUNCTION CODE	3-3
TABLE 3-3	SVC 1 COMMAND FUNCTION CODE	3-4
TABLE 3-4	SVC 1 DEVICE INDEPENDENT STATUS BYTE	3-5
TABLE 3-5	SVC 6 PARAMETER BLOCK FIELDS	3-17
TABLE 3-6	SVC 6 FUNCTION CODES	3-19
TABLE 3-7	SVC 6 ERROR CODES	3-20
TABLE 3-8	SVC 7 STATUS BYTE	3-25
TABLE 3-9	SVC 7 DEVICE ATTRIBUTES HALFWORD	3-29
TABLE 3-10	EXAMPLE DEVICE CODES	3-30
TABLE 5-1	TASK QUEUE ITEMS	5-6
TABLE 5-2	TASK TRAPS	5-6

CHAPTER 1

SYSTEM OVERVIEW

INTRODUCTION

OS/16 MT2 is a multi-tasking Operating System designed for INTERDATA 16-Bit Architecture Processors. The user should be familiar with the information in the following documents:

16-Bit Processor User's Manual, Publication Number 29-509

This manual is intended as a programming reference manual for OS/16 MT2. For information on operating OS/16 MT2 refer to:

OS/16 MT2 Operators Manual, Publication Number 29-430

Other manuals related to OS/16 MT2 are:

OS/16 MT2 System Planning and Configuration Guide, Publication Number 29-431

OS/16 MT2 Pocket Guide, Publication Number 29-433

OS/16 MT2 Program Logic Manual, Publication Number 29-434

A complete bibliography and subject index are contained in Appendix 9 of the *OS/16 MT2 System Planning and Configuration Guide*

The OS/16 MT2 Multi-Tasking Operating System provides an efficient and powerful means for using the resources of an INTERDATA 16-Bit Processor and its environment. Through easy to use services and efficient resource management, the user is free to concentrate on problem solving rather than on system management. OS/16 MT2 provides:

System control services through the Command Processor

Program control services through the Task Management Facilities of the Executive.

Memory management through the Executive.

Direct Access and Non-direct Access data management services through the File Manager and Device Drivers.

Figure 1-1 illustrates the components of OS/16 MT2 and their relationships.

System control is supported both from the system console and from user specified files or devices. The OS/16 MT2 Command language may be extended through the facilities of the Command Substitution System (CSS) to allow invocation of complex control sequences with a single command.

Program control support includes background and foreground facilities so that program preparation can proceed concurrently with real-time system operation. Intertask communication, task handled traps, single tasking, multi-tasking and parallel tasking support is provided.

Memory management facilities include multiple task common areas and resident library partitions, and multiple overlay area capabilities for user tasks. Storage management services are provided by the Executive for orderly memory management by user tasks. Foreground tasks are protected from undebugged background tasks. User space is divided into partitions established at system generation time. Partition sizes can be changed dynamically by the system operator

The OS/16 MT2 File Manager and Device Drivers provide a powerful set of data management services for both Direct Access and non-Direct Access devices. Two types of Direct Access file organization are supported: Contiguous and Indexed. Both static and dynamic protection is provided for I/O devices and Direct Access files.

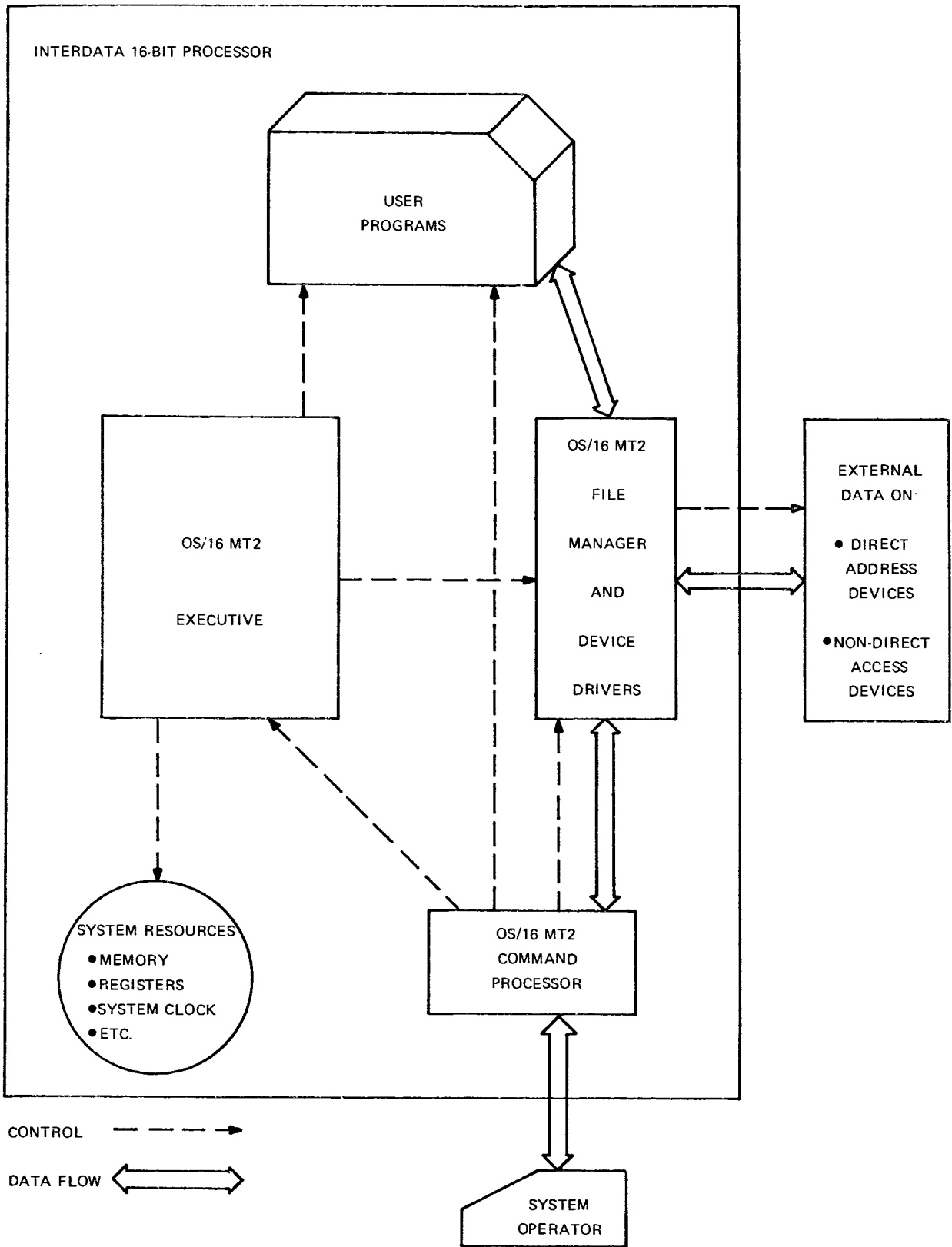

Figure 1-1. OS/16 MT2 System Overview

The OS/16 MT2 user can access the facilities of the system through either of two interfaces.

1. Operator interface; provided by the command language of the OS/16 MT2 Command Processor.
2. Program interface: provided by Supervisor Call (SVC) instructions serviced by the OS/16 MT2 Executive and File Manager.

In order to provide powerful facilities in the most efficient manner, an OS/16 MT2 System can be tailored to a specific hardware and system environment through the OS/16 MT2 system generation (SYSGEN) procedure. In addition, non-critical portions of the Operating System may be maintained on a Disc and brought into memory only when necessary, greatly reducing the memory requirements of the system

OS/16 MT2 can function as a subset of OS/32 MT for applications programming. Indexed and Contiguous Disc files are compatible between OS/16 MT2 and OS/32 MT.

MANUAL ORGANIZATION

This manual is intended for use as a programming reference manual. Chapter 1 describes the system in general terms. Chapter 2 provides information on task control at the program level. Chapter 3 describes the Supervisor Call (SVC) instructions supported by OS/16 MT2. Chapters 4, 5, 6, and 7 provide introductory guides to the use of SVC 2 facilities, task handled traps, Direct Access files, and user task overlays. Chapter 8 provides detailed device dependent information for I/O programming.

SYSTEM DESCRIPTION

Tasks

Program control services are provided for controlling a single task or a complex system of tasks. A task may consist of a single program, or it may include a main program with a number of subroutines and overlays. Tasks may be permanently resident in memory, or they may be loaded as required. Tasks are referred to by a Task Identifier (TASKID) which is associated with the task at load time. The number of tasks allowed in memory at one time is limited only by the number of partitions established at system generation time.

The following sections describe two pairs of task categorizations.

Foreground/Background Tasks

Tasks resident in a foreground memory partition are referred to as foreground tasks while a task resident in the background partition is referred to as the background task. Foreground tasks have the full range of OS/16 MT2 services available while a background task has the following restrictions:

- Intertask communication facilities are not supported.
- Task priority is under console operator control.
- A background task may not communicate with the foreground tasks through Task Common

This prevents a background task from interfering with the foreground system, thus providing a safe environment for task debugging.

Tasks may be established as tasks by processing the main program and any subroutines or overlays with the OS/16 Task Establisher Task (TET/16). The output of TET/16 may then be loaded by a foreground task or by an operator command. TET/16 output consists of a record which contains the Loader Information Block (LIB) followed by records which contain a memory image of the established task. The LIB contains information needed by the resident image loader to ensure proper loading of the task.

Alternatively, a task may be loaded directly in object format (output of CAL – the INTERDATA Common Assembler) by the background or the foreground object load operator commands, if it consists of a single program, or after processing by the OS/16 Library Loader, if it consists of multiple programs and subroutines.

User/Executive Tasks

At task establishment time, a task may be designated as a User task or an Executive task. User tasks (U-tasks) run in a protected mode while Executive tasks (E-tasks) have the full range of 16-bit architecture capabilities available. E-tasks capabilities are designed to provide an orderly and well defined means for adding system extensions.

Previously Written 16-bit programs

Programs written for previous operating systems (BOSS, DOS, or RTOS) must run with the compatibility option, due to differences in the SVC 1 and SVC 5 parameter blocks. See the *OS/16 MT2 Operators Manual*.

Program Addresses and Logical Segments

The process of establishing a user task via TET/16 produces a memory image load module of the task. This means the task may be loaded by simply reading it into the appropriate memory partition. At assembly time, whether the task consists of assembly language programs or FORTRAN output, the program references data and instructions using program addresses which are usually relative to the first location of the task. At task establish time, these addresses are converted to addresses within the partition that the task is being established for, or to addresses within the specified task common or library partition (see Chapter 5 of the *OS/16 MT2 Operator's Manual* for task establishment procedures). Thus an established task can contain references to several disjoint ranges of contiguous addresses: addresses in the program's partition, those in a task common partition, and those in a library partition. Each range of contiguous addresses is termed a *Logical Segment*. The three possible logical segment types are

- Program Segment
- Library Segment
- Task Common Segment

Status

A task in memory may be in any of five states. These are:

- Current
- Ready
- Wait
- Paused
- Dormant

The Current task is the one executing instructions. Only one task may be in this state at any given instant in time. All other tasks in memory are in one of the other four states, but may become the Current task depending on circumstances.

A Ready task is one which has no obstacles to becoming the Current task. It is eligible to be scheduled (i.e., become Current) whenever it becomes the highest priority Ready task.

A task in Wait state is one which may not become Ready until some specific circumstance has occurred. Among the possible wait states are:

I/O Wait	Waiting for I/O completion
Time Wait	Waiting for an interval or time of day
Trap Wait	Waiting for a task-handled trap
SVC Wait	Waiting for an SVC executor

A Paused task is one which may not execute until it is explicitly continued by the console operator. A Paused task is said to be in Console Wait.

A Dormant task is one which may not execute until it has been explicitly started, either by the console operator or another task. When a resident task goes to End of Task (EOT), it enters the Dormant state. When any task is loaded, it enters the Dormant state after loading is complete, and remains in this state until it is started.

Paused and Dormant are both Wait states; they are listed separately since they require operator intervention.

Protection

User tasks run in a protected mode. This means that they cannot use any privileged instruction. Privileged instructions include all I/O instructions and any instruction that changes the state of the Processor, such as LPSW, EPSR.

In order to request I/O functions or any Processor state change, user tasks must use a Supervisor Call (SVC) instruction.

Command Processor Services

In OS/16 MT2, the console operator interface is provided by a task called the Command Processor. The Command Processor is an E-task which runs as the highest priority task in the system. All commands are interpreted and executed by the Command Processor which also performs all I/O requests to the console device. The *OS/16 MT2 Operators Manual* describes in detail the commands and procedures related to the Command Processor. The Command Processor task is included as a part of OS/16 MT2 and cannot be cancelled. When the Command Processor is the only task in the system (if there is a background task it must be Dormant), the system is said to be quiescent.

The Command Processor includes:

- Support for controlling the user memory partitions

- Command Substitution System (CSS) support which allows the OS/16 MT2 operator command language to be extended by user defined command sequences.

- Support for controlling I/O devices configured in the system.

- The object loaders which allow tasks to be loaded into memory.

The Command Processor module can be deleted from the system at system generation. Planning and programming for such systems is fully described in Chapter 2 of *OS/16 MT2 System Planning and Configuration Guide*

Memory Management

Memory in an OS/16 MT2 system is separated into two classes:

- User space
- System space

System space is discussed later. User space is divided into partitions. The maximum number of partitions is established at system generation time. The console operator may vary the sizes of the partitions when there is no task in an affected partition. OS/16 MT2 supports four types of partitions:

- Foreground
- Background
- Task Common
- Resident Library

Foreground Partitions

Up to 125 foreground partitions may be established at system generation time. Their size is set by operator command. When an established task is loaded by the console operator or by another foreground task, it is loaded into the partition associated with that task at establishment time.

Foreground tasks are permitted to request the loading and execution of other tasks, cancel these tasks or delete them from memory, or to pass parameters to other foreground tasks. In operator commands, a foreground partition is referenced by the TASK ID of the task loaded in it or by its partition number, if it is vacant.

Background Partition

OS/16 MT2 provides one background partition. Intertask service requests are treated as illegal or ignored (depending on the task option selected) when executed from the background task; therefore the background task may not directly affect the operation of any foreground task. A task in the background partition may not use Task Common nor make use of a resident library.

The size of the background partition is adjusted by the console operator when the start of the first foreground partition is adjusted. The size of the background is set to the memory between the top of the system and the first foreground partition. The background partition is always referenced by its name, .BG.

Task Common

A Task Common partition is a sharable foreground data partition and, as such, is accessible only to foreground tasks. OS/16 MT2 supports multiple Task Common Partitions. When a task is to use a Task Common partition, the user must specify the start address of the desired Task Common partition when establishing the task. At task execution time, the Task Common partition may be vacant, or it may be initialized by loading a task which defines the desired values. Although any task can reference only one Task Common partition, there can be several groups of tasks, each group referencing a different Task Common.

Resident Libraries

A resident library partition is a foreground partition containing sharable, reentrant routines. Multiple resident library partitions are supported by OS/16 MT2, although any task can reference only one resident library partition. All references to routines in a library segment are resolved at task establishment time. A resident library is essentially the same as any foreground task, it is loaded and deleted in the same manner. Background tasks that are established by TET/16 can not use foreground library partitions.

System Space

Certain memory areas in an OS/16 MT2 system are not occupied by any partition. These areas are known as *system space*. System space is used in OS/16 MT2 for two purposes: to hold the OS/16 MT2 code itself, and to hold certain tables and system data structures required for proper operation of the system and of the user tasks.

The OS itself and all static data structures (those that do not change in size during system execution) are located in the lowest part of physical memory, below the background partition. Dynamic data structures, such as File Control Blocks (FCBs) are located in the highest part of physical memory. These are the only two areas of system space; the remainder of physical memory is devoted to partitions.

Sample Memory Allocation

Figure 1-2 is a map of a hypothetical OS/16 MT2 system. The assumed configuration is a Processor with 64KB of memory. The OS is presumed to occupy 20KB. The partitions are as follows:

Task Common: 1KB
 Foreground: 2x4KB, 10KB
 Resident Library: 2KB
 Background: 16KB

The remaining 7KB is system space.

Memory Address (Hex)

1000 (7KB)	System Space
E400 (1KB)	Foreground Partition 5 (Task Common)
E000 (16KB)	Foreground Partition 4
B800 (4KB)	Foreground Partition 3
A800 (2KB)	Foreground Partition 2 (Resident Library)
A000 (4KB)	Foreground Partition 1
9000 (16KB)	Background Partition
5000	OS/16 MT2

Figure 1-2. OS/16 MT2 Memory Map Example

Resident Loaders

OS/16 MT2 provides three resident loaders: the memory image loader and the object format background and foreground loaders.

The memory image loader loads overlays, Task Common segments, resident library segments, and either foreground or background tasks. Since this loader loads memory image format, the task to be loaded must have been prepared with OS/16 Task Establisher Task. The image loader may be invoked by a foreground task or by operator command. This loader performs all functions as a subroutine of the calling task and it is interruptable but not reentrant. That is, higher priority tasks are not blocked by the loader but only one task can use the loader at a time. If the loader is in use at the time of a loader request, the invoking task is placed in a SVC 6 Wait state.

The object format loaders load tasks in object format (e.g., CAL or OS/16 Library Loader output) and are invoked by operator command.

Roll Out/In

OS/16 MT2 provides one level of automatic roll out for partitions in a Disc-based OS/16 MT2 system. At the time the partitions are established by the operator via the SET PARTITION command, a Contiguous file is allocated for each partition on the specified ROLL volume. On a memory image load request, if a task is to be loaded into a partition which already contains a lower priority task with the rollable option, the lower priority task is rolled out by writing the memory image of the partition to the allocated roll file, along with the necessary control information to restart the task. When the higher priority task is deleted from the system, the rolled out task is rolled in and it resumes execution from the point of interruption. A task is rolled out by a load request only if:

- it has the rollable task option set
- it is lower priority than the task being loaded
- there is no task rolled out from the specified partition
- there is no incomplete time interval for the task
- the task is not connected to a Trap Generating Device

If any of the above conditions are not met, the load request is rejected. While a task is rolled out, no other task can communicate with it.

Protection

Memory protection is achieved through the use of the Memory Protect Controller (MPC) which is optional in OS/16 MT2. Through the MPC, system space is protected against modification during user task execution and foreground partitions are protected against modification by an undebugged background task. Foreground tasks are allowed to communicate directly with each other. In addition, the Supervisor Call (SVC) handler prevents modification of memory outside a user task's allocation through a request for OS/16 MT2 services.

Task Overlays

To provide more efficient use of memory, OS/16 MT2 supports multiple overlay capabilities for user tasks. At task establishment time, the user may organize a task so that only those portions of the task that are necessary are in memory at any given time. The remainder of the task can be maintained on a device or file until needed. Task establishment facilities, and access to the memory image loader for overlay loading at run time, provide the ability to tailor the memory requirements of a task. Multiple overlay areas may be defined within the task's memory allocation and any number of overlay segments may be loaded into each area as needed, substantially reducing the amount of memory needed to run the task.

Executive Services

The OS/16 MT2 Executive provides control over, and extensions to, an INTERDATA 16-Bit Processor as well as providing task management facilities. All requests for OS/16 MT2 services are mediated by the Executive's Supervisor Call (SVC) handler. Other support provided by the Executive includes:

- Software emulation of Single and Double Precision Floating Point, Multiply and Divide, and List Instructions for processors that lack them.

- Support of Line Frequency and Precision Interval Clocks.

- Internal interrupt handling including Power Fail/Restore handling.

- Task scheduling and trap facilities

- External interrupt handling.

- Support via Supervisor Call (SVC) for most Command Processor services

Interrupts and Traps

In OS/16 MT2, as in most operating systems, all interrupts at the Processor level, both external and internal, are handled by the operating system. OS/16 MT2 provides an interrupt facility at the task level known as the *task-handled trap* facility. This facility permits a task to be interrupted from its normal execution sequence for any one of a variety of causes, both hardware and software-generated. This facility also allows one foreground task to pass a parameter to another foreground task via the receiving task's Task Queue, thus permitting the receiving task to determine the software defined reason for the interrupt. A task handled trap may occur for the following reasons:

- Power Restoration
- Addition of an item to the Task Queue
- Completion of an I/O proceed request
- External Interrupt from a Trap Generating Device
- Completion of a specified time delay
- Message received from another task

Task Status Word (TSW)

Traps and additions to a task's Task Queue are controlled through the task's Task Status Word (TSW), which is the task level analog of the 16-Bit Processor Program Status Word (PSW). This status word is used to enable or disable the various traps, enable or disable additions to the Task Queue, and to save the location counter and condition code of a task at the time of a trap.

Task-Handled Traps

The user task can enable or disable the various traps through manipulation of its Task Status Word; on the other hand, a user may ignore the task trap facility by choosing the default TSW at task establishment time. The following sections briefly discuss the various task-handled trap facilities.

Task Queue Service

OS/16 MT2 supports a Task Queue, which is a circular list in standard INTERDATA list processing format, that may be associated with a task. If enabled by its Task Status Word (TSW), the following conditions cause an item to be added to a task's Task Queue:

- Queuing of an item by another task
- Completion of an I/O proceed request
- External Interrupt from a Trap Generating Device such as the Eight-Line Interrupt module.
- Completion of a time interval
- Message received from another task

Power Restoration

A task can request a trap, through its TSW, on completion of the system power restoration sequence, instead of being paused as is the default action. Any I/O in progress has been aborted by the system prior to the trap, except for Direct Access I/O which has been retried. If a task has real-time considerations, power restore may indicate that an appreciable amount of time has elapsed while power was down. A Power Restoration trap may be used to re-establish time intervals or to retreat to a checkpoint for resumption of task execution in an orderly fashion.

Interrupts

The OS/16 MT2 Executive handles the following Processor internal interrupts and OS/16 MT2 generated interrupts in essentially the same way:

- Floating Point Arithmetic Fault (Processor)
- Fixed Point Divide Arithmetic Fault (Processor)
- Illegal Instruction (Processor)
- Memory Parity Error (Processor)
- Memory Protect Fault (Processor)
- Illegal SVC (OS/16 MT2)
- Illegal Address in SVC (OS/16 MT2)

On detection of any of these faults, default system action is to log a message to the system console and pause the current task. If no task is current (the fault occurs during system code execution), a system crash occurs. If the optional system crash handler is included during system generation, a descriptive crash code is displayed on the display panel and the Processor placed in the Wait state. The user task can override default system action for Arithmetic Faults by either disabling them or causing the system to simply log a message and continue.

Task Priority and Scheduling

OS/16 MT2 recognizes 256 task priorities from a high of 0 to a low of 255. Of these levels, 10 through 249 are available to user tasks while 0 through 9 and 250 through 255 are reserved for system use. Task priority is set initially at task establishment time; it may be altered dynamically by another foreground task or the operator, up to a maximum set at task establishment.

In OS/16 MT2, tasks are scheduled in priority order. Care should be taken in assigning priorities so that tasks which do not relinquish control of the Processor do not prevent lower priority tasks from executing. Tasks on the same priority level are selected for scheduling according to either of two rules selected at system generation time.

1. Tasks residing in lower partition chosen ahead of tasks in higher partition (i.e. Task in partition 1 scheduled ahead of task in partition 2).
2. Round-Robin scheduling The most recently scheduled task on the current highest priority level is selected for scheduling after all other tasks on the same level. In this scheme, a queue is kept of ready tasks ordered by priority. When a task relinquishes control of the system it is placed at the end of its priority queue.

A task relinquishes control of the Processor in any of the following events.

It is Paused by the console operator

It is Cancelled

A higher priority task becomes ready because of an external event.

It Executes a request for an OS/16 MT2 service which places it in a Paused, Wait, or Dormant state.

Data Management Services

In order to provide device independent input/output programming, programs direct all I/O requests to a Logical Unit (LU) number instead of to a specific device or file. The system maintains a Logical Unit Table (LTAB) for each task. LU numbers, which range from zero to a limit set at system generation time (maximum 63), correspond to LTAB entries for the task. The LUs referenced by a task must be assigned to the specific devices or files by the operator or by the task prior to their use. This allows different devices and files to be used without program recompilation.

Devices

Input/Output support of peripheral devices such as card readers, line printers, etc. is provided by the various Device Drivers. This support is provided to enable a program to be written so that any device supporting the necessary operations may be used. Most drivers also provide support for device dependent operation so that special features and capabilities of the device may be used. In general Direct Access Files and peripheral devices may be accessed compatibly. Devices are referenced by a device mnemonic which is initially specified at system generation time. This name can be changed dynamically by the console operator or by an Executive Task (E-task).

Direct Access Files

All direct-access devices supported by OS/16 MT2 may be accessed through the OS/16 File Manager, which provides a substantial and powerful set of volume and file management services.

Data on a direct-access device is maintained as files on a named logical volume in a compatible manner with OS/32. Each volume contains all the information necessary to process the data on that volume. While a direct-access device is marked off-line, it is referred to by the device mnemonic associated with the device at system generation time. When a direct-access device is marked on-line, the name of the volume mounted on that device is associated with the device and used to refer to it. Volumes must not be dismounted without marking the device off-line.

Before using a direct-access volume, it must be formatted by the Common Disc Formatter, program number 06-173, or the Common MSM Disc Formatter, program number 06-201, and initialized for OS/16 use by the OS/16 MT2 INITIALIZE operator command.

Volume Organization

Allocation of space on an OS/16 volume is made in a flexible way, in order to reduce the adverse effects of any defective sectors. Only one sector is specifically required to be valid, this is Sector 0, Cylinder 0. On this sector the system maintains the Volume Descriptor. All other structures on the disc are allocated by the system wherever feasible.

The Volume Descriptor consists of three fields as illustrated by Figure 1-3

Volume Name
 Pointer to File Directory
 Pointer to Allocation Map

The remainder of the Volume Descriptor is reserved for future expansion

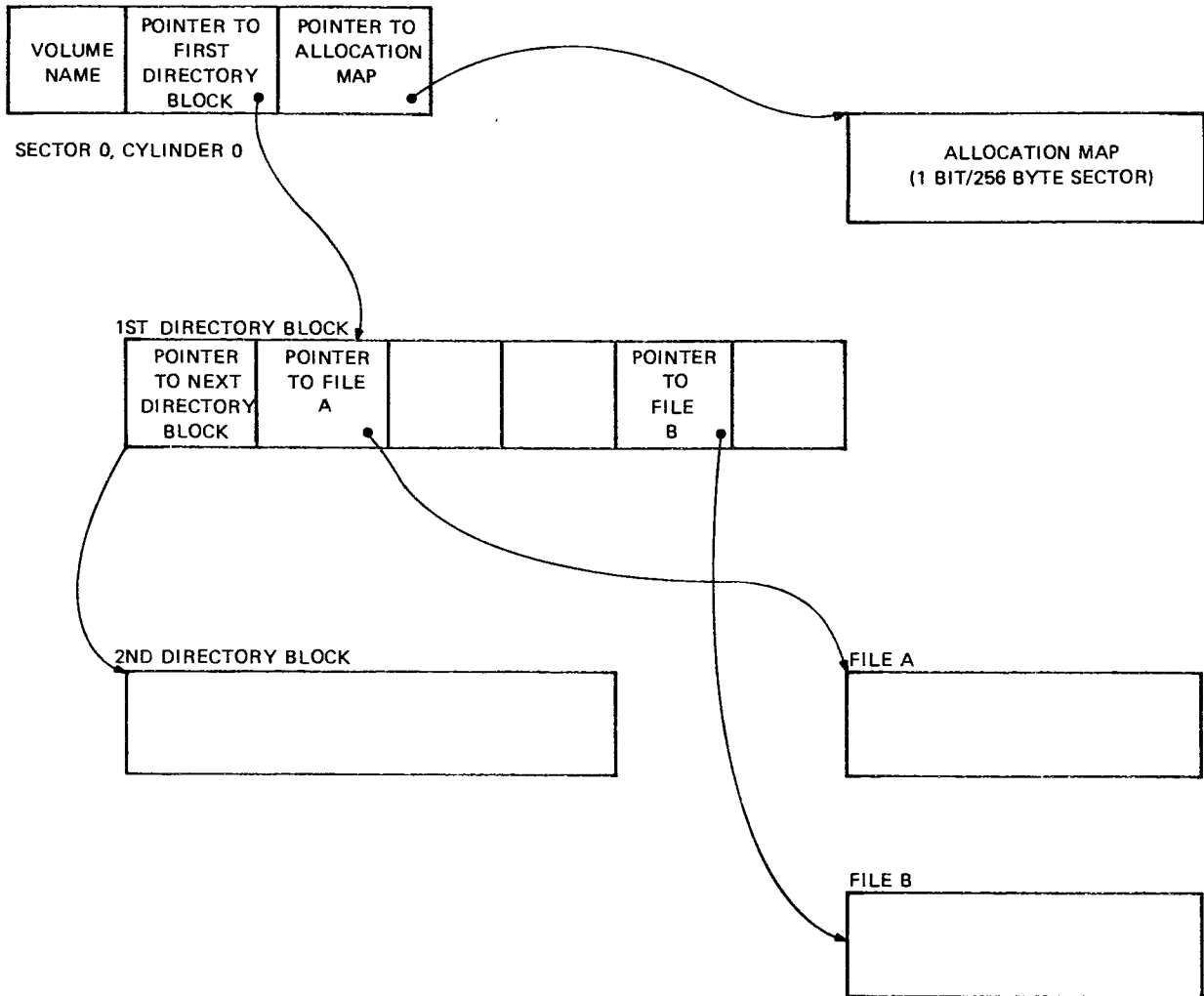

Figure 1-3. Volume Organization

Volume Name field contains a one to four-character ASCII volume identifier. This is the name by which the volume is known to the system.

Pointer to File Directory and Pointer to Allocation Map fields point to the first sectors of the File Directory and Allocation Map, respectively.

All data is initially placed in the Volume Descriptor by the OS/16 INITIALIZE command.

The Allocation Map is a bit-map having one bit for each sector on the volume. Since a sector occupies 256 bytes, the bit-map overhead is only 0.05% of the space on the volume. This map is used only to record allocated, unallocated and defective sectors. If a sector is allocated or defective, its corresponding bit in the Allocation Map is set to ONE; if unallocated, to ZERO.

The File Directory contains information needed by the system to process files recorded on the volume. An entry in the directory is made for each file.

The directory itself is organized as a chain of one-sector blocks. A directory block contains up to five file entries.

When a direct-access volume is initialized, a number of File Directory blocks are pre-allocated. When the first file on the volume is allocated, the first file entry in the directory is then marked as in use and the remaining four as not in use. As new directory blocks are needed, they are chained to the end of the File Directory.

Identification of Files

An OS/16 file is identified by a File Descriptor, which has three parts: volume name, file name, and extension.

The volume name is composed of from one to four alphanumeric characters, of which the first character must be alphabetic. This is the name of the volume on which one file resides.

The filename consists of from one to eight alphanumeric characters, of which the first must be alphabetic. This is the main identifier for the file, and may be anything the user chooses.

The extension consists of up to three alphanumeric characters. It may consist of no characters at all, in which case it is considered to consist of blanks. The extension usually denotes the type of material on the file. It may be anything the user chooses; however, some specific extensions are used by OS/16 and by some OS utilities, and are assumed to have specific meanings. These extensions are:

OBJ	Absolute or Relocatable loader format
FTN	FORTTRAN source format.
CAL	CAL assembly language source format.
BAS	BASIC source format.
CSS	Command Substitution System source format.
TSK	Task Image format.
ROL	System roll file
SPL	Printer spool file
PRT	Printer spool file
MAC	CAL Macro source format

The user may use any of these standard extensions, or may define others.

File Descriptors are written as follows.

VOLN:FILENAME.EXT

where VOLN is the volume name, FILENAME is the file name, and EXT is the extension. VOLN and EXT may be omitted when default names are assumed, such as the system volume and a blank extension.

A File Descriptor is also used to describe a device, in which case the VOLN field describes a device mnemonic rather than a volume name. The colon following the device mnemonic must be retained to avoid confusion with a file specification having a default volume name and extension. The FILENAME and EXT fields are ignored for devices and should not be used.

File Organization

A file is a collection of related records. From a programmer's point of view, a file is made up of logical records which may be of arbitrary length and structure, and are process-dependent. From the system's point of view, a file is made up of physical blocks which are of fixed length appropriate to the particular device and are process-independent. When a user program is written, the logical file structure must be considered because certain information is required at execution time by the I/O processor routines and therefore must be supplied by the user program. When a file is allocated, the manner in which the data is to be stored physically on the device must be specified.

OS/16 MT2 supports two file structures. Although these structures differ, in many cases the same data manipulations can be performed on one structure as another. The choice of file structure, in most applications, does not depend on the form of the data to be put in the file, but on the way in which the data is accessed. OS/16 MT2 file structures are each optimized for one specific form of access.

Indexed Files

The Indexed file is an open ended file structure consisting of two types of physical blocks: a chain of index blocks and individual data blocks pointed to by the index blocks. Figure 1-4 illustrates the relationship of the two types of blocks.

Both the index blocks and data blocks may be scattered on the volume. An Indexed file may be accessed sequentially or randomly. The index block structure reduces the number of physical accesses necessary to locate a specific data block.

Logical records may be added sequentially to the end of the Indexed file at any time. Existing logical records may be overwritten either sequentially or randomly, but cannot be deleted. For random access, logical records are referenced by a logical record number which is a number ranging from 0 to the number of logical records in the file minus 1. This logical record number indicates the order in which the logical record was added to the file.

When an Indexed file is allocated, the logical record size of the data to be contained is specified, as well as the physical block size of both the index blocks and the data blocks.

Access to the logical records on an Indexed file is via the Logical Buffered Access Method, which means that logical record length is independent of the physical block size specified for the data blocks. All blocking and deblocking is performed automatically by the OS via a buffer allocated in system space along with the File Control Block (FCB) when the file is assigned

Contiguous Files

The Contiguous file is a fixed-length file structure. All blocks of a Contiguous file are allocated contiguously on the volume as illustrated by Figure 1-4. The file size (in 256-byte sectors) is specified at the time of allocation, and all required space is reserved at that time. Each sector (block) is considered a record by the system. Random reads and writes may access any record on the file, regardless of which records have been previously accessed. This makes it possible to create a Contiguous file in a random fashion

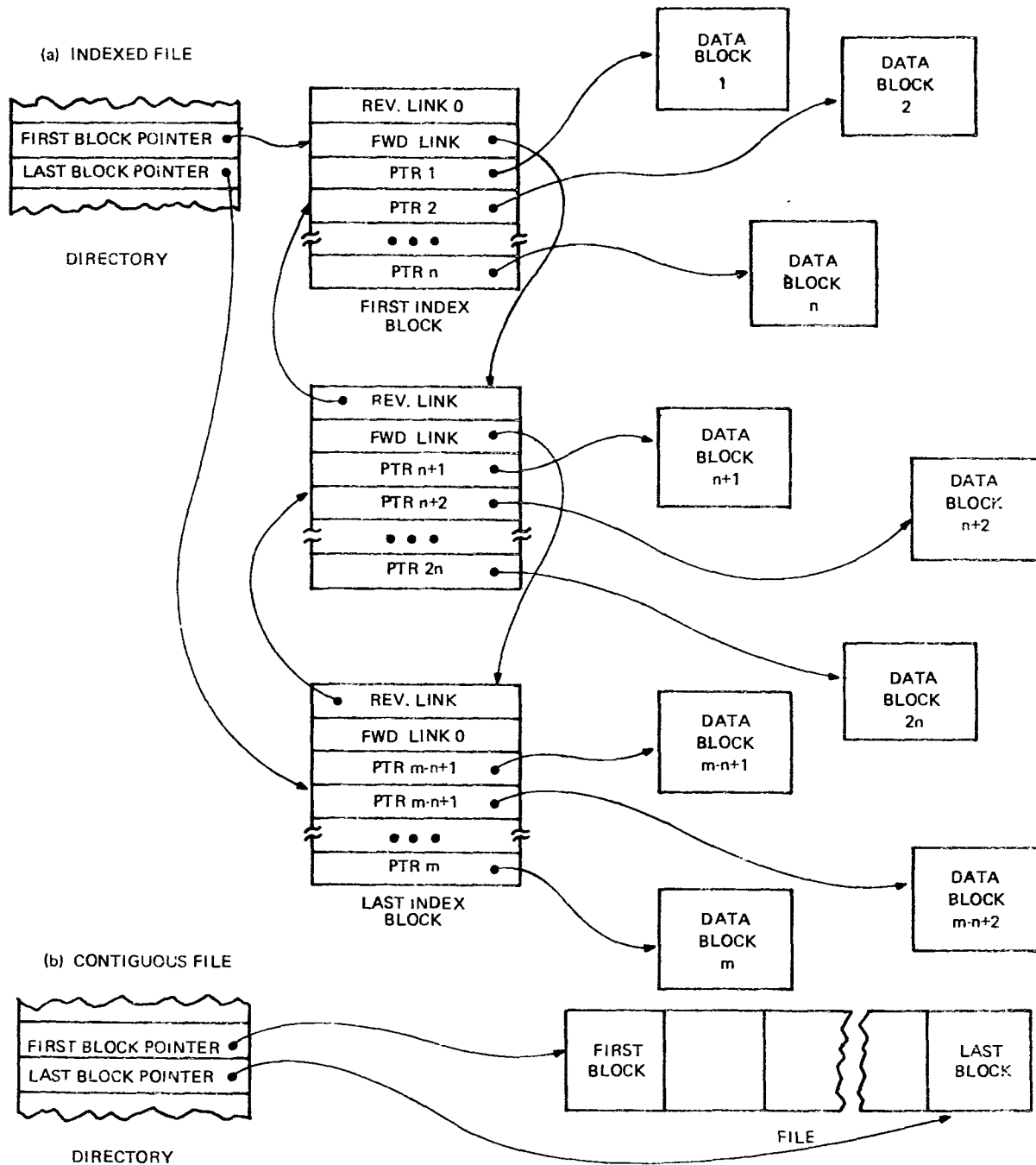

Figure 1-4. OS/16 MT2 File Structures

Contiguous file I/O is non-buffered and transfers a variable amount of data directly to or from the task's buffer. Although the user may transfer data in logical records of size greater or smaller than a sector, the appropriate sector number must be specified to position the file for random access. All transfers begin on a sector boundary and end whenever the specified number of bytes has been transferred.

The Contiguous file supports a pseudo filemark capability that gives it some of the characteristics of a magnetic tape device. A filemark is indicated by a halfword of X'1313' at the beginning of a record (block). Care should be taken to ensure that this datum is not inadvertently written at the beginning of a record if filemark operations are going to be used. The forward-file and backward-file operations, on a Contiguous file, function as they would on a magnetic tape. That is, the file is positioned forward or backward respectively until a filemark (X'1313') is found. The current record pointer is then left at the record following or containing this filemark, respectively. The write-filemark operation results in writing X'1313' at the beginning of the current record.

File Access Methods

OS/16 MT2 supports two methods of access to files: random and sequential. These methods may be intermixed without having to close and reassign the file. The chief mechanism used to implement these methods is the current record pointer.

The current record pointer is a number, ranging from zero to the number of logical records currently in the file, indicating the record to be read or written on the next sequential access to the file. Each record is numbered in sequence, starting with zero.

The current record pointer is adjusted in one of several ways:

1. It is set to zero by the following operations:
 - Rewind
 - Backspace to filemark (except on Contiguous files where the record pointer is positioned at the record containing the filemark)
 - Assigning (except for Write-only access)
2. It is set to the number of records in the file (the proper position to append new records) by the following operation:
 - Assigning for Write-only access
 - Forward to filemark (except on Contiguous files where the record pointer is positioned after the record containing the filemark).
3. It is decremented by one by a backspace record operation, unless the file is already positioned at its beginning.
4. It is incremented by one as follows:
 - Forward record (unless already at end of file)
 - Write filemark to a Contiguous file
 - Sequential Read or Write to an Indexed file
5. A random Read or Write sets the current record pointer to a value one greater than the record read or written.
6. It is incremented by the number of sectors that must be accessed to satisfy a sequential Read or Write request to a Contiguous file.

Random Access

For random access, the user supplies the record number that is to be accessed. This record is found, the data transfer is performed, and the current record pointer is set to point to the next sequential record. If the user continues to use random access, the current record pointer may be ignored, since it is readjusted on every call. However, the user may wish to read or write a sequence of records, starting with a known record number. In this case, a single random call followed by a number of sequential calls may be used.

With an Indexed file, the user is somewhat restricted in the use of the random Write call. This call may be used to update any record currently in the file, or to append one record to the end of the file. If the record number specified is more than one record past the end of the file, the call is rejected. This means that a file must be expanded in a sequential manner. If the file has only five records, a sixth may be added but record number 100, for example, may not.

On Contiguous files there is no restriction on the use of the random Write or Read call. Any record within the file's allocation may be read or written.

Sequential Access

Sequential access is the simplest and most common access method. The user performs a series of sequential Read or Write calls. These cause records of the file to be read or written in sequence. The current record pointer is adjusted automatically at each access. The Rewind, Forward Record, Backward Record, Forward File and Backward File commands may be used for repositioning as described previously.

File and Device Protection

Files and devices may be protected in one of two ways: statically or dynamically.

Static Protection

Each file or device has associated with it two protection keys, one for Read access and one for Write access. Each key is one byte long and may have any value from X'00' to X'FF'.

If the values of the keys are within the range of X'01' to X'FE', the file or device may not be assigned for Read or Write access unless the operator or requesting task supplies the matching keys.

If a key has a value of X'00', the file or device is unprotected for that access mode. Any key supplied is accepted as valid.

If a key has a value of X'FF', the file is unconditionally protected for that access mode. It may not be assigned for that access mode to any user task, regardless of the key supplied. An unconditionally protected file may be assigned to an Executive task, including the Command Processor.

Some examples of static protection follow.

<u>Write Key</u>	<u>Read Key</u>	<u>Meaning</u>
00	00	Completely unprotected.
FF	FF	Unconditionally protected.
07	00	Unprotected for Read, conditionally protected for Write (user must supply Write key = X'07').
FF	A7	Unconditionally protected for Write, conditionally protected for Read
27	32	Conditionally protected for both Read and Write.

The protection keys of a file are defined when the file is allocated, and may be changed by the console operator or by any task having that file assigned for exclusive Read/Write access (See Dynamic Protection)

The protection keys of a device are set to zero at system generation time, and may be changed by the console operator or by an E-Task.

Dynamic Protection

When a task has assigned a file, it may wish to prevent other tasks from accessing that file while it is being used. For this reason, the user may ask for exclusive access privileges, either for Read or Write, at assignment time. This form of protection is called dynamic because it is only in effect while the file remains assigned.

The access privileges are generally known by their abbreviations. These are:

SRO	Shared Read-Only
ERO	Exclusive Read-Only
SWO	Shared Write-Only
EWO	Exclusive Write-Only
SRW	Shared Read-Write
SREW	Shared Read, Exclusive Write
ERSW	Exclusive Read, Shared Write
ERW	Exclusive Read-Write

A file cannot be assigned with a requested access privilege if that assignment is incompatible with some other existing assignment of that file. For example, a request to assign a file for Exclusive Write-Only is compatible with an existing assignment of that file for SRO or ERO, but is incompatible with any existing assignment for other access privileges. Table 1-1 shows compatibilities and incompatibilities between access privileges.

Write Protection

All files on a disc volume may be protected from Write operations by marking the disc on-line as a protected device. When a volume is marked as being Write protected, all assigns for access privileges other than Shared Read Only (SRO) and Shared Read/Write (SRW) are rejected with a privilege error: Shared Read/Write (SRW) is changed to Shared Read Only (SRO). If the hardware write protected feature of a disc is enabled, the volume must be marked on-line as a protected volume.

Null Device

If a task performs I/O requests via SVC 1 calls, but no actual transfer is desired (possibly during testing), the Logical Unit (LU) used in the transfer may be assigned to the Null device before starting the task. The OS/16 MT2 Configuration Utility Program configures every OS/16 MT2 with a Null device which may be referenced by the File Descriptor:

NULL:

Read requests to the Null device return EOF status with the specified buffer unchanged. All write requests return with normal status and a length of data transfers of zero.

TABLE 1-1. ACCESS PRIVILEGE COMPATIBILITY

LU 1 \ LU 2	SREW	EWO	SWO	SRW	SRO	ERO	ERSW	ERW
SREW	-	-	-	-	*	-	-	-
EWO	-	-	-	-	*	*	-	-
SWO	-	-	*	*	*	*	*	-
SRW	-	-	*	*	*	-	-	-
SRO	*	*	*	*	*	-	-	-
ERO	-	*	*	-	-	-	-	-
ERSW	-	-	*	-	-	-	-	-
ERW	-	-	-	-	-	-	-	-

* = compatible
 - = incompatible

CHAPTER 2

TASK MANAGEMENT

TASKS

Tasks are controlled by OS/16 MT2 through two system control blocks: the Task Control Block (TCB), and the User Dedicated Locations (UDL). The TCB is maintained in system space and therefore cannot be modified by a user task. The User Dedicated Locations (UDLs) are maintained in the task's own allocation, therefore providing a measure of self-control to the task. This chapter describes the data structures and services related to task management.

Most of the services described here are invoked through the Intertask Communication Supervisor Call (SVC 6) described in Chapter 3.

Interrupts and Traps

In OS/16 MT2, as in most operating systems, all interrupts at the processor level, both external and internal, are handled by the operating system. OS/16 MT2 provides an interrupt facility at the task level known as the task-handled trap facility. This facility permits a task to be interrupted out of its normal execution sequence for any one of a variety of causes, both hardware and software-generated. This facility also allows one foreground task to pass a parameter to another foreground task via the receiving task's Task Queue, thus permitting the receiving task to determine the software defined reason for the interrupt. A task handled trap may occur for the following reasons:

- Power Restoration
- Addition of an item to the Task Queue
- Completion of an I/O proceed request
- External Interrupt from a Trap Generating Device
- Completion of a specified time delay
- Message received from a task

Task Status Word (TSW)

Traps, and additions to a task's Task Queue are controlled through the task's Task Status Word (TSW), which is the task level analog of the 16-Bit Processor Program Status Word (PSW). This status word is used to enable or disable the various traps, enable or disable additions to the Task Queue, and to save the location counter and condition code of a task at the time of a trap. TSW bit assignments are shown in Figure 2-1. The current Task Status Word (TSW) is maintained by the system for each task in its Task Control Block (TCB). The initial value of a task's TSW is set by the user (or by default) at task establishment time.

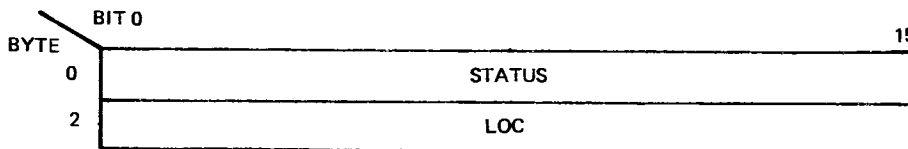

Figure 2-1. Task Status Word (TSW)

Task Status Word is 32 Bits. First halfword (bits 0-15) contains status defined in Figure 2-2. Second halfword (bits 16-31) contains the current location counter as in a PSW.

BIT	HEX MASK	NAME	DESCRIPTION
0	8000	W	Trap Wait Task suspended until a task trap occurs
1	4000	P	Power Restoration Trap Enable. A task trap occurs on completion of system power restore sequence
2-3			Reserved Must be Zero
4	0800	Q	Task Queue Service Trap Enable A task trap occurs when an item is added to the Task Queue Also a trap occurs if a TSW is loaded with this bit set and the Task Queue is not empty
5			Reserved Must be Zero
6	0200	D	Enable Task Queue entry on interrupt from a connected Trap Generating Device.
7	0100	T	Enable Task Queue entry on Queue Parameter (SVC 6) request directed at this task.
8	0080	Z	Enable Task Queue entry on completion of a time interval
9	0040	O	Enable Task Queue entry on completion of I/O proceed request.
10			Reserved. Must be Zero.
11	0010	E	Enable Task Queue entry on send message
12-15	000F	CC	Condition Code (as in PSW)

Figure 2-2. Task Status Halfword

User Dedicated Locations (UDL)

A minimum of 36 bytes at the start of a task's program address space must be reserved for the User Dedicated Locations. A 68 byte UDL is required for a task which uses Single Precision Floating Point, and 132 bytes for a task which uses Double Precision Floating Point (with or without single precision). The UDL contains system pointers, TSW swap areas, and other data used for communication between the operating system and the task, plus floating point register save areas as required. A map of the UDL is given in Figure 2-3. A task's UDL will, by default, be reserved and initialized to zero by TET/16 when the task is established. The UDL can then be set up dynamically by the task at run-time, if necessary. Alternatively, the UDL area can be assembled as part of the task, or as a sub-program to be included as the first part of the task. The program containing the UDL must be biased at the first address of the specified partition during task establishment. See Chapter 5 of the *OS/16 MT2 Operator's Manual* for further information.

- CTOP This location contains the address of the highest halfword in the task's allocated memory (program segment). This address does not reflect the possible use of a resident library or Task Common partition.
- COMBOT This location is provided for compatibility with previous INTERDATA operating systems. COMBOT is always set equal to CTOP in OS/16 MT2.
- UTOP This location contains the address of the first halfword following the user program. This value may be modified by the use of Get and Release Storage Supervisor Calls (SVC 2). UTOP always contains an address aligned on a halfword boundary.

- UBOT** This location contains the lowest address in the user program segment.
- TSW Swap areas** These are provided for Power Restoration and Task Queue Service Traps. They are each four halfwords in length. The first two halfwords of each location serve to save the previous TSW when a trap occurs; the new TSW is taken from the second two halfwords.
- A(TASKQ)** This location contains the address of the Task Queue. It must be set up by the program prior to enabling any entries to the Task Queue. If the contents of this location is zero, no Task Queue entries are made, regardless of the state of the TSW enable bits for Queue entry.
- A(MESSAGE BUFFER)** This location contains the address of a 74 byte buffer beginning on a halfword boundary. This field must be set up by the task prior to receiving a message. If the content of this location is zero, no message can be received regardless of the TSW queue entry enable bit.

0 (0)	CTOP	2 (2)	COMBOT
4 (4)	UTOP	6 (6)	UBOT
8 (8)	A(TASKQ)		
10(A)	POWER RESTORE OLD TSW SAVE AREA		
14(E)	POWER RESTORE NEW TSW		
18(12)	TASK QUEUE SERVICE OLD TSW SAVE AREA		
22(16)	TASK QUEUE SERVICE NEW TSW		
26(1A)	A(MESSAGE BUFFER)	28(1C)	RESERVED
30(1E)	RESERVED		
36 (24)	SINGLE PRECISION FLOATING POINT REGISTER SAVE AREA		
68(44)	DOUBLE PRECISION FLOATING POINT REGISTER SAVE AREA		
132(84)			

Figure 2-3. User Dedicated Locations (UDL)

TASK-HANDLED TRAPS

When a condition occurs that causes a trap, a TSW describing the routine to handle the specific type of trap is loaded from the appropriate new TSW in the task's User Dedicated Locations (UDL), the task's current TSW is saved in the UDL and control is passed to the routine to handle the trap. It is the trap routine's responsibility to save all general or floating point registers used within the routine prior to servicing the trap. A Load TSW Supervisor Call (SVC 9) is used to load the saved current TSW, thus returning control to the normal execution sequence.

If a task is in any Wait state other than Trap Wait, a trap does not actually occur until the task has left that Wait state. The TSW swap occurs upon detection of the condition causing the trap; however, the task remains in the Wait state until the reason for that wait is removed. Multiple TSW swaps may occur before the task leaves the Wait state, if so enabled. It is the responsibility of the user to assemble, or dynamically prepare, the desired new TSWs in the UDL for each type of trap, if the task trap facility is to be used.

Task Queue Service Traps

Since several trap-causing conditions may occur before the first trap is handled by the task, the Task Queue facility is provided to allow for queuing of trap information during periods when the task is unable to service a trap.

The following trap-causing conditions cause an item to be added to the task's Task Queue:

- Addition of a parameter to the Task Queue
- Completion of an I/O proceed request
- External Interrupt from a Trap Generating Device
- Termination of a specified time delay
- Message received from a task

As shown in Figure 2-2, each of these reasons can be independently disabled by setting the appropriate enable bit to ZERO.

The Task Queue is a "circular list" in the standard INTERDATA list-processing format. This list may be of any size desired, and may be located anywhere within the user program. It should be large enough to contain all parameters which may be queued at any one time. If the queue is full, attempts to add to the queue are rejected by SVC 6. A pointer to this list must be placed in the User Dedicated Locations by the program before enabling Task Queue entries.

The system always adds items to the bottom of the Task Queue.

Table 2-1 lists the parameters that are added to a Task Queue by the OS. If the Task Queue is full, any entries the system attempts to queue are lost.

TABLE 2-1. TASK QUEUE ENTRY TYPES

TYPE	CONTENTS
Device Interrupt	Parameter associated with device in SVC 6 connect time
SVC 6 Queue Parameter	Parameter specified in Add Parameter To Task Queue call (SVC 6)
I/O Proceed Complete	Address of I/O Call (SVC 1) parameter block.
Interval Completion	Parameter specified at interval initiation (SVC 2 Code 23)
Task Message	Address of message buffer

Power Restoration Traps

A task may wish to be informed if the processor has executed a power fail/restore sequence. Upon power failure, OS/16 MT2 saves all necessary data so that system operation can resume when power is restored. Although the system is able to resume normally, the same is not always true of tasks, since I/O requests may have been aborted or a time interval may have been missed.

Any I/O operation in progress when power fails is aborted. If the operation is on a direct-access device, the system is able to retry it when power is restored; however, on other than direct-access devices, a retry is generally impossible. These I/O operations, therefore, return an unrecoverable error status to the task.

If a task has real-time considerations, power restoration may indicate that an appreciable amount of time elapsed while power was down. This fact, and the lack of knowledge at the task level as to how long the power outage lasted, may pose substantial difficulties to a real-time task.

The normal course of events, in case of power outage, is to pause all tasks in the system. However, a task may choose to take a Power Restoration trap, instead of being paused.

If this is the case, the task should keep the P bit (Bit 1) set in its current TSW. Then, whenever there is a power outage, a TSW swap occurs upon restoration of power, and the task can go about the business of recovering from the power outage.

Trap-Generating Devices (TGD)

In certain applications, it is desirable for a task to respond to interrupts from some external device. OS/16 MT2 provides a set of facilities to allow this to be done.

Certain drivers, in particular the Eight-Line Interrupt Module driver, are capable of adding a parameter to a task's Task Queue in response to an interrupt from the device. The addition to the Task Queue can cause the task to take a trap, if enabled. For this reason, these devices are called Trap-Generating Devices (TGD) and their drivers are called TGD drivers.

Most devices, such as TTY, Card Reader, et cetera, are not capable of being used in this way. The only driver offered with OS/16 MT2 that supports TGD functions, is the Eight-Line Interrupt Module driver.

The functions provided by OS/16 MT2 for the handling of TGDs implement the entire ISA (Instrumental Society of America) proposed standards for process control. These functions are:

Connect	attaches a TGD to a task
Thaw	enables interrupts on a TGD
SINT	simulates an interrupt on a TGD (Addition to ISA standard)
Freeze	disables interrupts on a TGD
Unconnect	detaches a TGD from a task

INTERRUPTS

Interrupts handled by the OS/16 MT2 Executive are: Floating Point and Fixed Point Divide Arithmetic Faults, Illegal Instruction, Machine Malfunction, and Memory Protect Fault.

Floating Point and Fixed Point Divide Arithmetic Faults

When an Arithmetic Fault interrupt occurs, the task causing it may either be paused or continued, depending on selected task option. In either case, a message is output to the system log. The task has the further option of disabling arithmetic fault interrupts entirely, by the use of the Set Status Supervisor Call (SVC 2 Code 4). If an Arithmetic Fault occurs in system code execution, the crash handler is entered.

Illegal Instruction

If the illegal instruction was executed within system code, the crash handler is entered; if the illegal instruction was executed within user code, a message is output to the system log and the task is paused.

The previous statement does not apply if the illegal instruction interrupt was caused by the execution of a floating-point, multiply/divide or list instruction on a system using software traps. In that case, the appropriate trap routine is entered and the execution of the instruction is emulated.

Machine Malfunction

The machine malfunction interrupt occurs on memory parity error, power failure, and power restoration

A memory parity error causes a system crash if it occurs within system code; otherwise, a message is output to the system log and the active task is paused. Memory parity errors may occur when addressing non-existent memory in a processor with the parity feature installed.

Power failure causes the system to prepare for an orderly shutdown and to prime itself to await the machine malfunction interrupt that is to occur on power restoration

On power restoration, a message is logged requesting the console operator to reset all I/O devices (such as disc, which may not be ready or may come up in a Write-disabled state). When this message is acknowledged by the operator, all pending I/O requests are terminated, except those on direct-access devices, which are retried. All tasks in memory are then paused, except for those with a TSW enabling a task-handled trap on power restoration. The SET TIME command should be used to reset the clock as soon as possible following power restoration.

Memory Protect Fault

This interrupt occurs when a task attempts to violate the conditions of memory protection imposed by the Memory Protect Controller (MPC). A message is output to the system log and the errant task is paused.

TASK STATUS AND OPTIONS

Task Status and Options halfwords are maintained by the system in the Task Control Block (TCB) Task Options, in general, define overall characteristics of the task while the Task Status defines the state of the task. Tables 2-2 and 2-3 define the meanings of the Status and Options halfwords.

TABLE 2-2. TASK OPTIONS

BIT	HEX MASK	MEANING
0	8000	Executive Task (E-task) if 1 User Task (U-task) if 0
1	4000	Arithmetic Fault Continue if 1 Arithmetic Fault Pause if 0
2	2000	Task uses Single Precision Floating Point registers if 1 Task does not use Single Precision Floating Point registers if 0
3	1000	Task is Memory Resident if 1 Task is non-resident if 0
4	0800	Task uses BOSS/DOS/RTOS SVC 1 format if 1 Task uses OS/16 MT2 SVC 1 format if 0
5	0400	Task is the background task if 1 Task is a foreground task if 0
6	0200	SVC 6 ignored (Background only) if 1 SVC 6 illegal (Background only) if 0
7	0100	Task is rollable if 1 Task is not rollable if 0
8		Reserved for system use
9	0040	Task uses Double Precision Floating Point registers if 1 Task does not use Double Precision Floating Point registers if 0
10-15		Reserved for system use

TABLE 2-3. TASK STATUS BITS (TCB)

BIT	HEX MASK	MEANING IF SET
0	8000	Dormant
1	4000	I/O Wait
2		Reserved
3	1000	Roll Wait
4		Reserved
5	0400	Console Wait (Paused)
6	0200	Time Wait
7	0100	Trap Wait
8	0080	SVC 2 Wait
9	0040	SVC 5/6 Wait
10	0020	SVC 7 Wait
11	0010	Reserved
12	0008	DCB Wait (File I/O Wait)
13-15		Reserved

CHAPTER 3

SUPERVISOR CALLS

SVC INSTRUCTIONS

The SVC instruction enables a user task to communicate with the operating system and to use the software facilities provided. Execution of an SVC instruction at the assembly language level causes an internal interrupt which is processed by the Executive of OS/16 MT2. Higher level languages provide statements which generate SVC instructions.

The general form of an SVC instruction is:

SVC n,P

Where:

- n specifies the particular SVC
- P represents a parameter or the address of a parameter block which further defines the request. Parameter blocks must be aligned on a halfword boundary.

Valid SVC Calls

OS/16 MT2 provides all SVC instructions supported by OS/32 MT except for the OS/32 AIDS Support Supervisor Call (SVC 14), although not every option of each OS/32 MT SVC is supported. Table 3-1 summarizes the SVCs supported by OS/16 MT2.

TABLE 3-1. OS/16 MT2 SUPERVISOR CALLS

SVC	CODE*	FUNCTION
1		I/O Request
2	1	Pause
	2	Get Storage
	3	Release Storage
	4	Set Status
	5	Fetch Pointer
	6	Unpack
	7	Log Message
	8	Interrogate Clock
	9	Fetch Date
	15	Pack Numeric Data
	16	Pack File Descriptor
	17	Mnemonic Table Scan
	18	Move ASCII Characters
	19	Peek
	23	Timer Management
3		End of Task
5		Fetch Overlay
6		Intertask Coordination
7		File Management Services
9		Load TSW

*The code number appears in the SVC 2 parameter block

SVC Errors

OS/16 MT2 processes errors in an SVC instruction by issuing a message to the system console and pausing the task

The two possible error condition, and their causes are:

1. Illegal SVC which indicates an illegal SVC number (n), or invalid parameter specified in the parameter block.
2. Invalid Address in SVC which indicates an invalid parameter block address (not in task's allocation, or not on a halfword boundary), or an invalid address specified in a parameter block.

In either case the address of the errant SVC instruction is displayed in the message

SVC 1 – INPUT/OUTPUT REQUEST

SVC 1 is used by a task to perform all I/O requests. The parameter block format required to define the request is:

0(0)	FUNCTION CODE	1(1)	LOGICAL UNIT
2(2)	DEVICE INDEPENDENT STATUS	3(3)	DEVICE DEPENDENT STATUS
4(4)	BUFFER START ADDRESS		
6(6)	BUFFER END ADDRESS		
8(8)	RANDOM ADDRESS (4 BYTES)		
12(C)	LENGTH OF DATA TRANSFER		
14(E)	COMMUNICATIONS EXTENDED OPTIONS (ITAM/16 ONLY)		

18 (12)

This parameter block must be on a halfword boundary and must be in a writable segment of the program address space. An SVC 1 call may be coded as follows:

SVC	1,PARBLK	
.		
.		
.		
ALIGN	2	
DB	X'function code'	FUNCTION CODE
DB	X'logical unit'	LOGICAL UNIT
DS	2	STATUS
DC	A(START)	START ADDRESS
DC	A(END)	END ADDRESS
DC	Y'RANDOM'	RANDOM ADDRESS
DS	2	LENGTH OF DATA TRANSFER
DC	Y'COMOPT'	COMMUNICATIONS OPTIONS

Data Transfer Requests

The function code field for a data transfer request is defined in Table 3-2.

TABLE 3-2. SVC 1 DATA TRANSFER FUNCTION CODE

BIT	ALIGNMENT	MEANING
0	X	This bit must be ZERO to indicate a data transfer request.
1-2	.XX. . . .	Read-Write bits The meaning of these two bits is modified by bits 3-7 to control the transfer Basically the values are: 10 - Read request 01 - Write request 11 - Test and Set request (see Chapter 8 on Contiguous Files) 00 - Wait only or Test I/O Complete
3	. . X . .	ASCII/BINARY bit. This bit indicates the type of formatting requested if Bit 7 is reset. 0 - indicates ASCII formatting 1 - indicates binary formatting If Bit 7 is set, this bit must be ZERO
4	. . . X . .	PROCEED/WAIT bit. This bit indicates the action to be taken after the I/O has been initiated. 0 - Proceed Indicates that control is to be returned to the task after initiation of I/O. 1 - Wait. Indicates that the task is to be put into I/O Wait until the data transfer is complete.
5 X .	SEQUENTIAL/RANDOM bit. 0 - Sequential. Indicates the next logical record is to be accessed. 1 - Random. Indicates the logical record specified by the RANDOM field is to be accessed.
6 X	UNCONDITIONAL PROCEED bit. 0 - indicates the task is to be put into I/O wait until the requested device/file is free. At that time the request is processed. 1 - indicates that the request is to be rejected with a condition code of X'F' if the requested device/file is not free
7 X	FORMATTED/IMAGE bit. 0 - indicates that the request is to be formatted according to the device/file and the setting of Bit 3. For communications devices indicates default extended options to be used 1 - indicates that no formatting is to be performed (Image mode) For communications devices indicates Extended Option field applies.

In general, the request is defined by the logical OR of the function code bits. The ZERO setting of each bit is valid for all devices/files. If any invalid ONE setting of a bit is specified, the request is rejected by the OS as an illegal function (see STATUS byte definition).

For example, a function code of X'5C' specifies a request for:

Read (X'40')
Binary Formatting (X'10')
Wait I/O (X'08')
Random Access (X'04')

The full SVC 1 parameter block, except the communications extended options field, must be reserved for data transfer requests. Wait only and Test I/O complete requests make use of the function code, logical unit, and status fields only, so the remaining fields may be redefined and used by the task (e.g., for storing constants, etc.).

Command Function Requests

The function code for a command function request is defined in Table 3-3

TABLE 3-3. SVC 1 COMMAND FUNCTION CODE

BIT	ALIGNMENT	MEANING
0	x	This bit must be set to indicate a command function request. This bit alone requests Halt I/O
1	x	Rewind
2	. x . . .	Backspace Record
3	. x . . .	Forward Space Record
4	. . x . .	Write File Mark (EOT for communications device.)
5	. . . x .	Forward Space File
6 x	Backspace File
7 x	Reserved for driver dependent functions

The implementation of all commands is device-dependent and is explained for each driver in Chapter 8. The implementation of command functions for direct-access files is also explained in Chapter 8.

When multiple bits in the command function code byte are set, the following principle applies:

The function code is scanned from left to right. The leftmost bit found that is meaningful to the device assigned to the specified logical unit indicates the function to be performed.

If no valid function is indicated by the function code, the system returns immediately to the user, with normal status. Note that this condition is not considered an error. The user may find out which command functions are supported on any Logical Unit by means of the Fetch Attributes (SVC 7) call.

Most drivers do not make use of the fields following the Device Dependent Status field (for commands). If the user is certain that no special drivers are to be used by the task, these fields may be put to other uses, e.g., the storing of constants, etc. However, for a fully device-independent program, it would not be appropriate to use these fields.

Logical Unit (LU)

In order to provide device independent I/O, all I/O requests are directed to a Logical Unit (LU). An LU is a number from 0 to a SYSGENed maximum (up to 31) which describes an entry in the task's LU table. The particular device or file desired must be assigned to the specified LU via operator command (see *OS/16 MT2 Operator's Manual*), or SVC 7 call prior to executing the SVC 1 call. If an invalid or unassigned LU is specified, the call is rejected. If no operation is desired, the specified LU should be assigned to the Null device.

Error Status (Device Dependent and Device Independent Status)

The system returns the status of the requested function in the Device Independent Status byte. This Status byte is set to indicate the general type of error that occurred. If there was no error, it is set to zero. In addition, the processor's Condition Code is set to zero. In the case of a rejected Unconditional Proceed call, the Condition Code is set to X'F'.

The Device Dependent byte is set to zero along with the Device Independent Status byte, if there is no error. In case of error, a code further explaining the error status is returned in the Device Dependent Status byte.

The system does not modify the contents of the STATUS bytes until the requested function is complete or an error has been detected. While the function is in progress, the previous contents of these bytes are left unchanged

Specific interpretations of the error codes as they apply to devices and files are explained in Chapter 8. The general definition of the status bits is given in Table 3-4.

TABLE 3-4. SVC 1 DEVICE INDEPENDENT STATUS BYTE

BIT	MEANING IF SET TO ONE	BINARY	HEXADECIMAL
0	Always 1 for error status		
1	Illegal Function	1100 0000	X'C0'
2	Device Unavailable	1010 0000	X'A0'
3	End of Medium	1001 0000	X'90'
4	End of File	1000 1000	X'88'
5	Unrecoverable Error	1000 0100	X'84'
6	Recoverable Error	1000 0010	X'82'
7	Illegal or Unassigned LU	1000 0001	X'81'

The SVC 1 Device Dependent Status byte is defined as follows:

X'82'	I/O terminated by time-out
X'81'	I/O terminated by Halt I/O

If no dependent status is available, the Device Dependent Status byte contains the device number.

In general, for a data request, if Illegal Function, Device Unavailable, or Illegal LU status is indicated, then no data was transferred. Otherwise, some data may have been transferred. Device Unavailable may indicate that the device is physically inoperative. If the device becomes unavailable after a transfer is started, Unrecoverable Error is set to indicate the possibility that data was transferred.

The Illegal Function bit is set whenever the system cannot accept the SVC 1 Function Code byte as specified, for a data transfer. This may be for one of the following reasons:

1. A modifier was specified that is not supported by the device; e.g., Binary on a CRT.
2. A function was specified that is not supported by the device; e.g., Read on a Line Printer.
3. A function was specified that is not supported by the access privileges granted at Assign time; e.g., Read on a file that is assigned for Write-Only access.

Buffer Address

For data transfer requests, the buffer must be specified by the buffer start and buffer end address fields. The buffer start address is the first byte in the buffer and the buffer end is the last byte in the buffer (not the first byte after the buffer).

All buffers must be on a halfword boundary and must be fully contained in the same logical segment. Buffers used in Read requests must be in a writable segment.

An Invalid Address in SVC error occurs if:

- Buffer is not on halfword boundary
- Buffer start and end are not in same logical segment
- Buffer end address is less than buffer start address
- Buffer for Read request is in Write-protected logical segment

Random Address

The Random Address field is 4 bytes long and is used to specify the logical record number (starting at 0) to be accessed on data transfer requests if function code Bit 5 is set. The interpretation of this field is device or file dependent and is defined in Chapter 8.

Length of Data Transfer

This field is used to return the actual number of bytes transferred during a data transfer request. This field is most useful when dealing with variable length record devices, such as magnetic tape. This field is undefined if an error status is returned. (See note in the section entitled Test I/O Complete.)

Unconditional Proceed

Unconditional proceed I/O is used when a task does not wish to wait for the requested device or file to be free. I/O requests are coordinated by the system so that only one I/O request may access any device at a time. If Unconditional Proceed is not requested, and the specified device is in use at the time of the data transfer request, the calling task is placed in I/O Wait until the device is free. At that time, the I/O request is initiated. If Unconditional Proceed is specified and the specified device is in use, the SVC 1 request is rejected. Error status is set to zero (normal), and the condition code is set to X'F'. The calling task may then retry the request at a later time. If the specified device is not in use, the setting of the Unconditional Proceed Bit has no effect on the request.

Wait/Proceed I/O

Once an I/O request has been initiated (that is, the specified device is free), an I/O Proceed call (Bit 4 of function code reset) causes control to be returned to the task so that the task may execute concurrently with the transfer. The status is not set until completion of the I/O (except for Illegal function and Illegal LU which are detected before transfer initiation).

The status of the request may be checked by

- Monitoring the status field in the parameter block
- Taking a task handled trap on completion
- Issuing a Wait Only request to the same LU to wait for completion
- Using Test I/O complete on the same LU to monitor the completion

An I/O and Wait call (Bit 4 of the function code set) cause the calling task to be placed in I/O wait until completion of the request.

Wait Only

A Wait Only request (function code X'08') causes the task to be placed into I/O wait until the completion of a previous I/O Proceed request to the specified LU. If there is no uncompleted I/O by this task to the specified LU, control is returned immediately. This call makes use of the FC, LU, and STATUS fields of the SVC 1 parameter block. Illegal LU is the only error status returned by this call. The status of the I/O being completed is returned in the parameter block associated with the original I/O Proceed call and not in the Wait Only call parameter block.

Test I/O Complete

A Test I/O complete call (function code X'02') returns with a condition code of X'0' if there is no uncompleted I/O Proceed call to the specified LU by the task. If there is an uncompleted I/O Proceed, the call returns a condition code of X'F'. Illegal LU is the only error status returned by this call. The status of the I/O being tested is returned in the parameter block associated with the original I/O Proceed call.

NOTE

For compatibility with older 16-bit Operating Systems, a task may use the compatibility option and use BOSS/DOS/RTOS SVC 1 parameter block format. Under this option, the length of data transfer field is unused, and the random address field is one halfword in length. For a wait-only call, the FC, LU and STATUS fields are used.

Halt I/O Command

Halt I/O allows a task to cancel an outstanding I/O and proceed request. This is particularly useful on an interactive terminal device, without the ability to Halt I/O, an outstanding read request must be satisfied before any other I/O can be started on that device.

The Halt I/O command is supported on all interactive terminal devices currently supported on the system; TTY Keyboard/printer, Carousel, CRT devices on a Current Loop or PASLA interface.

When a Halt I/O command is received, the system first verifies that it is a valid request:

1. The logical unit (LU) must be assigned
2. The device must support Halt I/O
3. The LU must currently have a proceed I/O request outstanding.

If it is found to be invalid, an error status is returned to the Halt I/O request parameter block. If the request is valid, the I/O operation is scheduled for termination and a status of zero is returned to the Halt I/O parameter block. The driver aborts the I/O and sets the status of the original I/O request to X'8281'.

The Halt I/O parameter block should not be the same one originally set up to request the I/O, as a result of the Halt I/O request, status will be returned to both parameter blocks. After the SVC 1 is issued, the Halt I/O status should first be checked to ensure that the system considers the request valid. The possible values are:

X'0000'	The requested I/O termination has been scheduled
X'8100'	The LU was not assigned
X'82dn'	No I/O on-going for this LU
X'C0dn'	Device does not support Halt I/O

where

X'81'	= unassigned LU
X'82'	= recoverable error
X'C0'	= illegal function
dn	= device number

The task will take a trap when the I/O completes if Proceed I/O traps and Task Queue Entries are enabled; exactly as for any other Proceed I/O completion. The parameter added to the queue is the address of the original data transfer parameter block. If traps are not enabled, the task can wait for completion of the Halt I/O with an SVC 1 wait only request.

On completion due to Halt I/O request, the status returned is.

X'8281'

where

X'82'	= recoverable error
X'81'	= device dependent status indicating Halt I/O request

Note that support for the Halt I/O function is a **SYSGEN** option. On any system configured without this support, no device will support Halt I/O, and an error status of X'C0' indicating illegal function will be returned on any Halt I/O request.

SVC 2 – GENERAL SERVICE FUNCTIONS

This SVC provides a number of general service functions. These functions relate to the task's communication with the console operator, to memory allocation, to text-processing and command-processing functions, and to timer management.

All SVC 2 calls require a parameter block. The general structure of an SVC 2 parameter block is as follows

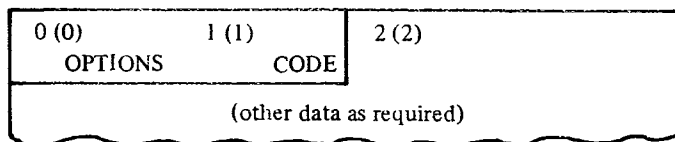

The CODE byte is a decimal number which may range from 0 to 255. Not all of the 256 possible codes are implemented at this time, unrecognized codes are rejected as illegal SVCs. The SVC 2 codes implemented in OS/16 MT2 are shown in Table 3-1.

The OPTIONS byte is generally used to further modify the conditions of the call. Options may be used by individual SVC 2 codes as required, these are described in subsequent sections. For those functions for which no options are defined, the options byte is ignored.

The remainder of the parameter block may be as long or as short as required for proper operation of the SVC 2 code. All SVC 2 parameter blocks must be aligned on a halfword boundary.

Code 1 – Pause

This call is used to place a task in a Console Wait state. A PAUSE message is issued to the system log. If the operator enters a CONTINUE command at the system console device, the program is restarted at the instruction immediately following the supervisor call. The parameter block format is as follows:

PARBLK	ALIGN DB	2 0,1	NO OPTIONS
--------	-------------	----------	------------

Incomplete I/O Proceed requests continue to completion normally even while the task is in the PAUSED state.

Code 2 – Get Storage

This call is used to provide temporary storage locations for certain subroutines called by a program, in particular FORTRAN Run-Time Library subroutines. This call does not increase the size of the program's memory allocation, but obtains locations from the program's current allocation. The parameter block format is as follows:

PARBLK	ALIGN DB DC DC	2 OPTION,2 H'REG' H'SIZE'	DESIRED OPTION ADDRESS OF REGISTER NUMBER OF BYTES
--------	-------------------------	------------------------------------	--

Options allowed are

X'00' Get specified number of bytes
X'80' Get all allocated storage

If option X'00' is specified, the system adjusts the task parameter, UTOP, upwards by the number of bytes requested. The starting address of the storage obtained is returned in the designated register. Subsequent calls with this option obtain new areas. Since UTOP is maintained on a halfword boundary, requests are rounded up to the nearest halfword boundary.

If option X'80' is specified, the system sets UTOP equal to the task parameter CTOP+2, thus making available all of the task's current allocation. The starting address of the storage obtained is returned in the designated register and the number of bytes obtained is placed into the parameter block's SIZE parameter. The parameter block must be in a writable logical segment if this option is selected.

If the call is successful, the Condition Code is set to zero. If more storage is requested than is currently available, or a negative size is specified, an address of zero is returned, UTOP is not changed and the 'V' bit of the Condition Code is set (CC=4).

Code 3 – Release Storage

This call is the inverse of the Get Storage call (Code 2). It is used to release storage previously obtained. The format of the parameter block is as follows:

PARBLK	ALIGN	2	NO OPTIONS NUMBER OF BYTES TO BE RELEASED
	DB	0,3	
	DC	H'SIZE'	

This call does not reduce the program's memory allocation. The pointer UTOP is adjusted downwards by this call, but not below UBOT. Since UTOP always points to a halfword boundary, it is rounded up to the nearest halfword if the number of bytes released is not a multiple of 2. If the call would adjust UTOP below UBOT, or if a negative size is specified, UTOP is not changed and the Condition Code 'V' bit is set (CC=4), otherwise the Condition Code is set to zero.

Code 4 – Set Status

This call allows the user to modify the Floating Point Arithmetic Fault and Fixed Point Divide Interrupt Enable bits (AF) and the Condition Code (CC) of the PSW. Two options are provided. the first option specifies that all allowable bits be modified; the second option specifies that only the Condition Code be modified. The format of the parameter block is:

PARBLK	ALIGN	2	DESIRED OPTION NEW STATUS, CONDITION CODE
	DB	OPTION,4	
	DB	AF,CC	

The options allowed are:

X'00' Modify Status and Condition Code
X'80' Modify Condition Code only

The AF byte parameter indicates how arithmetic faults are to be handled and the valid combinations are:

X'00' Disable Arithmetic Faults
X'10' Enable Fixed Point Divide Faults
X'04' Enable Floating Point Arithmetic Fault
X'14' Enable both Fixed Point Divide and Floating Point Arithmetic Faults

The CC byte parameter has the form:

X'0x' where x is to replace the Condition Code.

Code 5 – Fetch Pointer

This SVC is used by a task that wishes to determine the extents of its memory allocation or to modify its UDL. It returns a pointer to the base of the task's User Dedicated Locations (UDL).

The format of the parameter block is as follows:

PARBLK	ALIGN	2	NO OPTIONS REGISTER SPECIFICATION
	DB	0,5	
	DC	H'REG'	

No options are recognized. The REG field contains the number of one of the user's general registers; the pointer to the base of the user's UDL is returned in this register.

Code 6 – Unpack Binary Number

This call is used to translate a binary number contained in user General Register Zero into ASCII decimal or hexadecimal format. The format of the parameter block is as follows.

PARBLK	ALIGN	2	DESIRED OPTION POINTER TO DESTINATION
	DB	OPTION,6	
	DC	A(DEST)	

The OPT field contains the supervisor call options. The ADDRESS OF DESTINATION field contains a pointer to a buffer in memory where the converted number is to be stored. This buffer may begin on any byte boundary; it must be in a writable logical segment.

Options recognized are as follows

X'00'+N Convert to hexadecimal
 X'40'+N Convert to hexadecimal, suppress leading zeros
 X'80'+N Convert to decimal
 X'C0'+N Convert to decimal, suppress leading zeros

N represents the length of the buffer, in bytes. If N is zero, a four-byte buffer is assumed. N must be less than or equal to 63 (X'3F'). Note that 5 is sufficient for decimal and 4 for hexadecimal.

The converted number is right-justified in the buffer so that the least significant digit occupies the rightmost byte (highest address) in the buffer. If the number to be converted exceeds the buffer length, most significant bytes are lost. If suppression of leading zeros is requested, the number is stored in the buffer right-justified, and the remaining characters, if any, are filled with blanks.

The number to be converted must be supplied by the user in General Register Zero, and is assumed to be an unsigned 16-bit binary number.

Code 7 – Log Message

This call provides access from the user task to the system console (or system log device). It gives the user a means of outputting a message with the assurance that it is printed on the console or log device regardless of Logical Unit assignments in force at the time of the call. A number of options are provided and the parameter block may take one of two forms, Direct and Indirect Text.

Direct Text

PARBLK	ALIGN	2	DESIRED OPTION LENGTH OF MESSAGE IN BYTES TEXT OF MESSAGE
	DB	OPTION,7	
	DC	H'LENGTH'	
	DC	C'TEXT'	

Indirect Text

PARBLK	ALIGN	2	DESIRED OPTION LENGTH OF MESSAGE IN BYTES ADDRESS OF MESSAGE TEXT
	DB	OPTION,7	
	DC	H'LENGTH'	
	DC	A(TEXT)	

Options recognized are:

X'00' Direct text, Formatted message
 X'40' Indirect text, Formatted message
 X'80' Direct text, Image message
 X'C0' Indirect text, Image message

The LENGTH field specifies the length of the message in bytes. This message may be of any length and may begin on a byte boundary (for the Indirect text option).

The Formatted/Image option is similar to the ASCII formatted/Image option in SVC 1. Its effect on the system console or log device cannot be properly predicted by the caller, however, since there exists no mechanism for fetching the attributes of the system console or log device. The Command Processor, therefore, may restrict the Image option by executing it as though it were Formatted for certain devices. The primary effect of the Image option on a TTY, Carousel, or CRT is to suppress the automatic carriage return at end of line, or to allow multiple line messages to be logged with one SVC call.

A Log Message call is treated as an I/O Proceed call. Message text is buffered within the system, enabling the user to modify or destroy the text or parameter block immediately following the call. If no entries are available on the log message queue, the message is lost. A message noting the lost message or messages is displayed in the system console.

Code 8 – Fetch Time

This call is used by a task to request the current time of day from the system. The system maintains a 24-hour clock calibrated in seconds since midnight. A value of zero indicates midnight; a value of 86399 (X'1517F') indicates 23:59:59. The clock may be interrogated in ASCII or binary format. The format of the parameter block is:

PARBLK	ALIGN	2	DESIRED OPTION ADDRESS OF BUFFER
	DB	OPTION,8	
	DC	A(BUFFER)	

Options recognized are:

X'00' ASCII format
X'80' Binary format

If ASCII is selected, the receiving buffer must be eight bytes long and may be aligned on a byte boundary, in a writable logical segment. The stored data is in the format:

hh mm:ss

If Binary is selected, the receiving buffer must be four bytes long and aligned on a halfword boundary. The data stored in it is a binary fullword indicating seconds since midnight, as described previously.

Code 9 – Fetch Date

This call is used to request the present date from the system. The format of the parameter block is:

PARBLK	ALIGN	2	NO OPTIONS ADDRESS OF RECEIVING BUFFER
	DB	0,9	
	DC	A(DEST)	

The receiving buffer must be eight bytes long and aligned on a halfword boundary, in a writable logical segment. The system returns the date in the following format:

mm/dd/yy

Alternatively, at system generation time, the following format may be selected:

dd/mm/yy

This format is widely used outside the United States and in certain governmental (chiefly military) applications within the United States.

Code 15 – Pack Numeric Data

This call is the inverse of the SVC 2 code 6 call. It translates ASCII hexadecimal or decimal character strings to binary numbers. An option is provided to skip leading blanks. The format of the parameter block is as follows.

PARBLK	ALIGN	2	DESIRED OPTIONS
	DB	OPTIONS,15	REGISTER HOLDING ADDRESS
	DC	H'REG'	

Options recognized are:

- X'00' Hexadecimal
- X'40' Hexadecimal, skip leading blanks
- X'80' Decimal
- X'C0' Decimal, skip leading blanks

The REGISTER field of the parameter block specifies one of the user general registers. This register must contain a pointer to the first character of the ASCII string to be converted. The result is always returned in General Register Zero.

This pointer register is returned pointing to the first byte in the string that could not be converted. (If decimal is specified, this is the first non-numeric byte, if hexadecimal is specified, this is the first byte that is not 0-9 or A-F). If Register Zero is specified as REG, the updated input pointer is not returned.

The Condition Code (CC) is set to reflect the results of the processing:

CC=0 means a normal termination with no errors encountered in packing

CC=1 ('L' bit set) means no characters were processed, in this case, general register 0 is set to zero.

CC=4 ('V' bit set) means that the number processed was too large to be represented in 16 bits. If hexadecimal is specified, this means that more than four valid hexadecimal digits were processed. In this case, Register Zero contains the least significant four characters.

If decimal is specified, this means that the number processed is greater than 2¹⁶-1 (65535). In this case, Register Zero contains the number processed, modulo 2¹⁶.

Code 16 – Pack File Descriptor

This call is used to convert an ASCII string containing a File Descriptor into the format necessary for a File Management Services Call (SVC 7). This call is particularly useful if the name of the system volume is not known to the caller. The format of the parameter block is:

PARBLK	ALIGN	2	DESIRED OPTIONS
	DB	OPTIONS,16	ASCII STRING ADDRESS REGISTER
	DC	H'REG'	ADDRESS OF RECEIVING AREA
	DC	A(DEST)	

The REG field specifies one of the caller's general registers. This register must point to the ASCII string to be processed.

The RECEIVING AREA ADDRESS field points to a 16-byte receiving area. This receiving area must be aligned on a halfword boundary in a writable logical segment and is formatted as follows:

0 (0)	VOLUME NAME	
4 (4)	FILE NAME	
12 (C)	EXTENSION	15(F) (reserved)

Note that this is the same format as the File Descriptor field of an SVC 7 parameter block. The receiving area may in fact be such a field.

Options recognized are:

X'00' Default System Volume
 X'40' Default System Volume, Skip Leading Blanks
 X'80' No Default Volume
 X'CO' No Default Volume, Skip Leading Blanks

If either "Skip Leading Blanks" option is selected, the SVC ignores all blanks from the current position of the pointer to the first non-blank. Otherwise, the File Descriptor to be converted is assumed to start at the current pointer position. The action of the "Default System Volume" options are shown later.

The pointer contained in Register REG is returned after the call pointing to the first byte that is not part of the File Descriptor. The Condition Code is set on return as follows:

0 normal
 1 no volume name present in input
 4 syntax error (input pointer not updated)
 8 no extension present in input
 9 no extension or volume name present in input

If a syntax error is detected, the contents of the receiving area are undefined. If volume name, file name or extension is fewer than 4, 8 or 3 characters long, respectively, the field is left justified and unused characters in the receiving area are blank-filled. The reserved character following the extension field is always set to a blank by the system.

If no volume name is provided and a "Default System Volume" option is selected, the current system volume name is moved into the VOLUME NAME field of the receiving area. If this option is not selected, the contents of the receiving area VOLUME NAME field are left unchanged.

For example:

	Input string	Receiving area	Condition Code
1.	DSC3:	DSC3bbbbbbbbbbb	8 (no extension)
2.	ABC:FILE1.XY	ABCbFILE1bbbXYbb	0 (normal)
3.	DEF:FILE2	DEFbFILE2bbbbbbb	8 (no extension)
4.	FILE4.PDQ	****FILE4bbbPDQb	1 (no volume)
5.	FILE5	****FILE5bbbbbbb	9 (no volume or extension)
6.	FRED:FILE5.	FREDFILE5bbbbbbb	0 (normal)
7.	\$3%X,CP%	undefined	4 (syntax error)

**** = volume name field contents depend on selected option

Note that the selection of the blank extension (example 6) is not considered the same as the selection of no extension at all. If no extension at all is selected, it is assumed that the caller may wish to use some default value.

Code 17 – Mnemonic Table Scan

This call permits the user to decode command mnemonics in a way identical to the OS/16 MT2 Command Processor. The format of the parameter block is as follows:

PARBLK	ALIGN	2	NO OPTIONS
	DB	0,17	
	DB	REG1,REG2	
	DC	A(MNEMONIC TABLE)	

The options byte must contain zero, as there are no options. The REG1 byte contains the number of a general register. This register is a pointer to the source string being scanned. The REG2 byte contains the number of a general register into which the result of the call is put. The MNEMONIC TABLE ADDRESS field contains the address of a mnemonic table within the user's program space.

The format of a mnemonic table is a string of mnemonics. No boundary alignments are required. Mnemonics within the table are separated from each other by bytes containing X'00'. The end of the table is signified by the occurrence of two consecutive bytes of X'00'.

M N E M 1 00 M N E M 2 00 M N E M 3 00 00

The first byte of a mnemonic may be any ASCII character; subsequent bytes of the mnemonic must be alphabetic. A mnemonic may be of any length. Abbreviations are permitted in the same way as described in the operator command syntax (see *OS/16 MT2 Operator's Manual*). To indicate an abbreviation, required characters of a mnemonic are flagged with Bit 0 = 1, non-required characters are flagged with Bit 0 = 0. Required characters must be contiguous and must begin with the first character of a mnemonic. Thus, the mnemonic RECONFIGURE is coded as:

DB C'R'+X'80',C'E'+X'80',C'C'+X'80',C'ONFIGURE',0

where the first three characters are flagged as required. Note the byte of zero at the end, this is the mnemonic terminator

The result, returned in Register REG2, is a number which is -1 if no match was found, or 0 to n-1, where n is the number of mnemonics in the table, if a match was found. This number represents the position of the matched mnemonic in the table, starting with zero. Thus, if a match is found on the third item in the table, the result returned in REG2 is 2.

REG1 is returned pointing to the first character that was not matched. This is normally a separator following the mnemonic in the string being scanned. If no match is found, Register REG1 is returned unchanged.

If a match is found, the Condition Code is set to zero, if no match is found, the Condition Code 'V' bit is set (CC=4).

Code 18 – Move ASCII Characters

This call is used to move characters from an input string to a target string. The number of characters moved may optionally be controlled by the presence of one or more terminating characters in the input string. The format of the parameter block is as follows:

PARBLK	ALIGN	2	OPTION INPUT, OUTPUT POINTERS ADDRESS OF ENDING CHARACTER STRING
	DB	OPTION,18	
	DB	REG1,REG2	
	DC	A(ENSTRING)	

REG1 specifies the register pointing to the input string and REG2 specifies the register pointing to the output string, which must be in a writable logical segment.

Options recognized are

X'00' + N	No ending characters
X'80' + N	Use ending character string

where N is the number of characters to be moved. N must be less than or equal to 127 (X'7F').

If option X'00' is selected, N characters are moved. The input and output string pointers are modified to point to the location following the last byte moved in the input and output areas, respectively. The Condition Code is set to zero.

If option X'80' is selected, each character moved is checked against the ending character string. If this character matches any of the ending characters, this character is not moved and the SVC terminates, modifying the pointers as described previously, and setting the Processor Condition Code to zero. If the Nth character is moved and no match has been found, the SVC terminates as described previously, but the 'V' bit of the Condition Code is set (CC=4) to signify that no ending character was found.

The ending character string is formatted as follows:

M	Ending characters
---	-------------------

where M is a byte containing the number of ending characters in the string. The length of the entire string, therefore, is M+1 bytes. A string containing, for example, the ending characters , , / is coded as follows

DB 5,C',,:/'

Code 19 – Peek

This call permits the task to extract certain system and task-dependent information from system tables. This information is moved to the caller's parameter block, which is 26 bytes long. The format is illustrated in Figure 3-1.

0(0)	00	1(1)	19	2(2)	NLU	3(3)	MPRI
4(4) OSID							
12(C) TASK ID							
20(14) CTSW				22(16) TASK OPTIONS			
24(18) TASK STATUS							

Figure 3-1. SVC 2 Code 19 Parameter Block

The first two bytes of the parameter block are set by the user program and indicate SVC 2 code 19. The remaining fields are filled in by OS/16 and have the following meanings:

NLU	Number of LUs available to the task
MPRI	Maximum priority of the task
OSID	Eight ASCII characters of the form "OS/16MT2r" where r is numeric and indicates the revision level of the OS/16 MT2 system.
TASK ID	Eight-character ASCII Task Identifier.
CTSW	Status field (upper 16 bits) of the task's current Task Status Word.
TASK OPTIONS	The Options halfword from the task's TCB.
TASK STATUS	The status halfword from the task's TCB

This parameter must be on a halfword boundary in a writable segment and may be coded as follows:

PARBLK	ALIGN	2
	DB	0,19
	DS	24

NOTE

This parameter block must be 26 bytes long if information following it is not to be overwritten.

Code 23 – Timer Management

This call permits the user to set up a time interval, and either to wait for that interval, or to cause an item to be added to the task's Task Queue when the interval is complete. Through the trap capability, it provides a very useful mechanism for service of periodic functions. This call also permits the user to cancel an outstanding time interval.

The parameter block has the following format:

ALIGN	2	
DB	OPTIONS,23	DESIRED OPTIONS
DC	H'REG'	REGISTER CONTAINING PARAMETER
DC	Y'TIME'	TIME FIELD

Bits 0-3 (TT) of the TIME field indicate the type of interval desired. The defined codes are:

- 0000 Seconds since midnight (Time of day interval)
- 0001 Milliseconds from now (Elapsed time interval)

All other codes are considered illegal, and cause an Illegal SVC error.

Bits 4-31 of the TIME field contain the number of clock ticks in the interval. This number can be no greater than $2^{28}-1$, (268,435,455 decimal, 0FFFFFFF hexadecimal). A clock tick is a second if TT=0000 or a millisecond if TT=0001

Options recognized are as follows.

X'00'	Add to Queue on completion of interval
X'80'	Wait until completion of interval
X'10'	Cancel time interval

If the Wait option is selected, the REG field of the parameter block is ignored. The task enters a time Wait state and does not leave it until the completion of the interval.

If the Add to Queue option is selected, the REG field of the parameter block contains the number of one of the user's general registers. This register contains a parameter that is to be added to the user's Task Queue on completion of the interval. A task may have only one active interval at any time. If a second interval is specified, it overrides the first. A time interval, once activated, cannot be deactivated unless the task goes to EOT before the interval is complete or a Cancel Time Interval is issued.

If the Cancel Time Interval option is selected, the REG and TIME fields of the parameter block are ignored. The outstanding time interval is cancelled and the Condition Code is set to zero. If no such interval is found, the V-bit of the Condition Code is set (CC=4).

SVC 3 – END OF TASK (EOT)

This call permits a task to terminate itself in an orderly fashion. Its format is

SVC 3,N EOT

There is no parameter block associated with this call. Instead, the effective address of the second argument, N, is treated as a binary constant, and replaces the Return Code used by the Command Substitution System (CSS) (see the OS/16 MT2 Operator's Manual).

Return Codes may be treated as desired by the user in CSS conditional testing, however, the CSS system assumes that Return Code 0 represents normal termination, 255 represents termination by the system or another task (Cancel).

If the task issuing this call has I/O in progress at the time the call is made, the I/O is terminated. Write operations are permitted to terminate normally, while Read operations are aborted.

If the task issuing this call is a nonresident task, its Logical Units are all closed, and it is removed from memory. If, however, the task issuing this call is a resident task, its files are checkpointed, but not closed, and it is not removed from memory.

N may consist of an indexed operand, e.g., 0(R1). In this case the Return Code is set to the sum of the contents of the specified register and the displacement.

SVC 5 – FETCH OVERLAY

This call permits a task to fetch an overlay from a specified Logical Unit. The format of the parameter block is as follows.

PARBLK	ALIGN	2	OVERLAY NAME (6 characters) RESERVED FOR OS/32 COMPATIBILITY STATUS OPTIONS LU NUMBER
	DC	C'OVLYNM'	
	DS	2	
	DB	0	
	DB	OPTIONS	
	DC	H'LU'	

Options recognized are:

X'01'	Load from LU without positioning
X'04'	Load from LU after rewind

Any other value in the OPTIONS byte is considered illegal and results in an Illegal SVC error.

The status returned is:

X'00'	Overlay loaded successfully
X'10'	Load failed (for various possible reasons)
X'20'	Mismatch on overlay name
X'40'	Overlay would not fit in allocated memory

The overlay file must be assigned to the Logical Unit specified in the parameter block. This file must be prepared by the OS/16 Task Establisher Task (TET/16). See Chapter 5 of the *OS/16 MT2 Operator's Manual* for the appropriate discussion of preparing tasks with overlays. The specified overlay name is checked against the name in the Loader Information Block of the overlay file. If it does not match, an error status is returned.

The calling program does not resume execution until the overlay is loaded. If the overlay is successfully loaded, the root program may Branch and Link to it as a subroutine. See Chapter 7 for a discussion of overlay facilities provided by TET/16.

If Load without positioning is specified, the file must be positioned at the LIB of the overlay to be loaded.

On return, the overlay file or device is positioned to the logical record following the last logical record containing the overlay.

The parameter block must be in a writable segment

SVC 6 – INTERTASK COORDINATION

SVC 6 provides facilities for foreground tasks to invoke and communicate with other tasks. SVC 6 is treated as an illegal SVC or a NOP (No Operation) from a background task, depending on the task option associated with the background task.

SVC 6 functions include the ability to:

- Load a task
- Start a task
- Cancel a task
- Queue a parameter to a task
- Change a task's priority
- Control Trap Generating Devices
- Make a task memory resident or non-Memory Resident
- Send a message to a task

The SVC 6 parameter block is 38 bytes long and must start on a halfword boundary in a writable segment. The format is illustrated in Figure 3-2.

0(0)		TASK ID	
8(8)		FUNCTION CODE	
12(C)		TASK STATUS	
14(E)		ERROR STATUS	
16(10)	LOAD LU	17(11)	PRIORITY
18(12)	RPRI	19(13)	RESERVED
20(14)			
START ADDRESS			
22(18)		DELAY TIME	
TT			
26(1A)			
DEVICE MNEMONIC			
30(1E)			
PARAMETER			
32(20)			
MESSAGE BUFFER ADDRESS			
34(22)			
RESERVED (4 BYTES)			

Figure 3-2. SVC 6 Parameter Block

The meaning of each field is explained in the description of each function requiring that field. Table 3-5 summarizes the use of each field. The parameter block may be coded:

PARBLK	ALIGN	2	
	DC	C'TASKID'	TASKID (8 bytes)
	DC	Y'function'	FUNCTION CODE
	DS	4	TASK ERROR STATUS
	DB	LU	LOAD LU
	DB	PRI	PRIORITY
	DS	2	RPRI/RESERVED
	DC	A(START)	START ADDRESS
	DC	Y'TIME'	TIME DELAY
	DC	C'DEVM'	DEVICE MNEMONIC
	DC	X'PARM'	PARAMETER
	DC	A(MESSAGE)	MESSAGE BUFFER ADDRESS
	DS	4	RESERVED

Although not all fields are used by each function, the full SVC 6 parameter block must be reserved.

TABLE 3-5. SVC 6 PARAMETER BLOCK FIELDS

FIELD	NAME	MEANING
Bytes		
0-7	Task ID	Name of task; not required if call is self-directed.
8-11	Function Code	Specifies desired functions, See Table 3-6
12-13	Task Status	The wait status halfword of the specified task is returned by the system in this field
14-15	Error Status	Set to ZERO for normal termination or to error code if error detected. See Table 3-7.
16	Load LU	Specifies LU from which to load the task. Used only for Load function.
17	Priority	Specifies priority for change priority function. May not be 255 (E-tasks). Must be in range 10-249 (U-tasks)
18	RPRI	Set by system to actual priority of specified task.
19		(reserved)
20-21	Start Address	Used only for START functions; specifies address at which to start specified task. If ZERO, signifies normal transfer address, as specified at TET/16 time.
22 (Bits 0-3)	TT	Time Type: indicates type of time delay Used only for Delay-Start. Legal codes are. 0000 = seconds since midnight 0001 = milliseconds from now.
22-25 (Bits 4-31)	Delay Time	Specifies number of seconds or milliseconds, as defined by TT field, to delay the start operation. Used only for Delay-Start.
26-29	Device Mnemonic	Specifies device affected by Connect, Thaw, SINT, Freeze and Unconnect functions. (See Table 3-6).
30-31	Parameter	Specifies parameter to be queued for Queue parameter function; specifies device parameter for Connect functions
32-33	A(Message)	Specifies address of message buffer for Send Message Function.
34-37		(Reserved)

Task ID and Function Code

The Task ID field specifies the name of the task at which the SVC 6 is directed. A Task ID must either be .BG for the background task or must consist of alphanumeric characters with the first character alphabetic. If the call is directed at the calling task (see function code D field), it is termed a self-directed call and the Task ID field is not required. A function may also be directed at the calling task by specifying Other-Task in the function code and the calling task's name in the Task ID field. The function code specifies the functions to be performed on the specified task. Each bit in the function specifies a separate function. The functions specified are performed in the order of designated bits from left to right. The definition of the function code bit assignments is given in Table 3-6.

Errors

If an error is detected in the performance of any requested function, an error status is returned and no further functions are performed. Since the Error Status field contains an indicator of which function was being performed at the time of error, it is always possible for the calling task to determine the functions that were performed and those that were not.

The format of the Error Status halfword is as follows:

BIT	0	7	8	15
NAME	Position Pointer			Error Code

The Position Pointer points to the field in the Function Code fullword that was being processed at the time the error was detected. This pointer takes the form of a bit pointer which may have values in the range 0 through 31. The possible values of the Error Code field are detailed in Table 3-7.

Status Return

No matter what functions are specified, and except for Error Code 4 (no such task), the Wait Status halfword and the current priority from the specified task's TCB are always returned in the Task Status and RPRI fields. This allows the calling task to restore the specified task to its previous priority. If only a status return is desired, it is permissible to set no bits in the function code (except for the Direction field). The entire SVC 6 call is then treated as a Null operation, but the status and priority are returned as usual.

TABLE 3-6. SVC 6 FUNCTION CODES

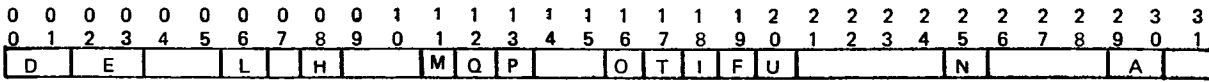

BIT(S)	NAME	HEX	MASK	MEANING
0-1	D	8000 C000	0000 0000	DIRECTION 00,01 = illegal codes 10 = Other Task 11 = self
2-3	E	0000 1000 2000 3000	0000 0000 0000 0000	END TASK. 00 = no function requested 01 = cancel 10 = delete 11 = delete
4-5				RESERVED (SET TO ZERO)
6	L	0200	0000	LOAD TASK
7				RESERVED (SET TO ZERO)
8	H	0080	0000	TASK RESIDENT
9-10				RESERVED (SET TO ZERO)
11	M	0010	0000	SEND MESSAGE
12	Q	0008	0000	ADD PARAMETER TO SPECIFIED TASK'S TASK QUEUE.
13	P	0004	0000	CHANGE PRIORITY OF SPECIFIED TASK.
14-15				RESERVED (SET TO ZERO)
16	O	0000	8000	CONNECT: CONNECT SPECIFIED DEVICE TO SPECIFIED TASK.
17	T	0000	4000	THAW: ENABLE INTERRUPTS ON SPECIFIED DEVICE.
18	I	0000	2000	SINT: SIMULATE INTERRUPT ON SPECIFIED DEVICE.
19	F	0000	1000	FREEZE: DISABLE INTERRUPTS ON SPECIFIED DEVICE.
20	U	0000	0800	UNCONNECT. DISCONNECT SPECIFIED DEVICE FROM SPECIFIED TASK.
21-24				RESERVED. (SET TO ZERO)
25	N	0000	0040	TASK NON-RESIDENT
26-28				RESERVED (SET TO ZERO)
29-30	A	0000 0000 0000 0000	0000 0002 0004 0006	START TASK: 00 = no function requested 01 = start immediately 10 = delay start 11 = delay start
31				RESERVED (SET TO ZERO)

TABLE 3-7. SVC 6 ERROR CODES

Code Dec (Hex)	Function(s)	Meaning
0(0)	All	No errors, all requested functions complete.
1(1)	All	Syntax error in Task ID field. Does not apply to self-directed calls
2(2)	---	Illegal function code
3(3)	L	Task already present.
4(4)	All but L	No such task in foreground.
5(5)	P	Invalid priority.
6(6)	L	Floating point not supported by SYSGEN.
7(7)	A	Specified task not dormant.
8(8)	S	Invalid Start address
10(A)	A (delay)	Invalid code in TT field
11(B)	M	Message not sent (Task unable to receive)
12(C)	Q	No queue, full queue, or entries disabled
13(D)	O,T,I,F,U	No such device in system.
14(E)	O,T,I,F,U	Device named is not a connectable device.
15(F)	O	Device is busy, cannot connect.
16(10)	T,I,F,U	Device not connected to specified task.
17(11)	L	Invalid or unassigned Load LU
18(12)	L	Checksum error.
25(19)	I	Device is not SINTable
66(42)	L	Resident Library or Task Common not present.
68(44)	L	Invalid format on Loader Information Block.
73(49)	L	Partition not vacant
74(4A)	L	I/O error on ROLL OUT
75(4B)	L	Assign/Close error on ROLL OUT.
76(4C)	L	Partition does not exist.
129-192 (81-C0)	L	I/O error reading Load LU, error status is as returned by SVC 1

End Task Function

Task ID and Function Code are the required fields.

This function causes the specified task to terminate as though it had executed an SVC 3,255.

The Return Code of 255 indicates abnormal termination. If Delete is specified, the task is made nonresident and then cancelled. This causes it to be removed from memory. If Cancel is specified, the task is removed from memory only if it is a nonresident foreground task. If this call is self-directed, SVC 6 processing is terminated. It is not permissible to specify this function with a LOAD or START since this is a proceed function.

Load Task Function

Task ID, Function Code and Load LU are the required fields.

The specified task is loaded from the Load LU. If a task is already present in the system with the given Task ID or the Task ID is invalid, the call is rejected. A self-directed load request is also rejected

The task to be loaded must have been processed with the OS/16 Task Establisher Task (TET/16). The Loader Information Block (LIB) is read from the specified LU which must have been previously assigned and positioned to the LIB. The partition required by the task (determined at TET/16 time) is checked to see if it is vacant, or contains a rollable task of lower priority. If not, the call is rejected. Upon loading the task, it is given the name found in the TASKID field.

To load a task into the background, the TASKID must be .BG. The background partition must be dormant for the load to occur.

On successful return from this call, the specified file or device is positioned after the loaded task.

Send Message Function

Task Id, Function Code and Message Buffer Address are the required fields.

This function provides the calling task with the capability of sending a message to the called task. The task to which a message is directed must have been set up to receive messages. On request, a message set up in the calling task is accessed by the system as 64 bytes of data. The Task Id of the calling task is appended as a header and a 72 byte message is passed to the receiving task. If the receiving of messages by that task is disabled an error status is returned.

The Message Buffer must be on a halfword boundary. The actual message may be less than 64 bytes even though 64 bytes will be sent. No checking or formatting of the message is performed. Refer to the section further in this chapter entitled "The Sending and Receiving of Task Messages" for more information.

Queue Parameter Function

Task ID, Function Code and Parameter are the required fields.

The parameter specified in the PARAMETER field of the parameter block is added to the specified task's Task Queue, if:

- the specified task has a Task Queue;
- that queue is not full; and
- the specified task's TSW enables entries to the Queue.

Otherwise, the call is rejected with appropriate error status.

Change Priority Function

Task ID, Function Code and Priority are the required fields.

This function changes the priority of the specified task from whatever it was before the call to the priority specified in the PRIORITY field of the parameter block. The call is rejected for U-tasks if the priority specified is outside the valid range of 10-249.

If the specified priority is greater than the established maximum priority of the specified task then the established maximum priority is used instead of the specified priority. This is not considered an error. RPRI is set to the priority of the task before it is changed.

Task Resident and Non-Resident Functions

Task ID and Function Code are the required fields

The Task Resident function makes the specified task memory resident. The Task Non-Resident function makes the specified task non-memory resident, allowing the task to be deleted when it goes to End of Task. Specifying Task Non-Resident and End Task does not delete the specified task because the task is cancelled and then is set Non-Resident.

Trap-Generating Device Functions

The functions Connect, Thaw, SINT, Freeze and Unconnect are provided for the control of Trap-Generating Devices (TGD). These functions all use the DEVICE MNEMONIC field of the parameter block. This field must contain the mnemonic of a TGD. For all functions except Connect, a test is made to make sure that the specified TGD is connected to the specified task.

A TGD may not be connected to more than one task at a time; however, a task may have any number of TGDs connected to it. The parameter that is placed in the Task Queue on a TGD interrupt can be used to differentiate between multiple TGDs connected to a task.

Connect

Task ID, Function Code, Device Mnemonic and Parameter are the required fields.

This function connects the TGD specified by DEVICE MNEMONIC to the specified task. The named device must be a TGD, it must not be connected to any other task, or already connected to the same task. The parameter specified by PARAMETER becomes associated with the TGD; this parameter is placed in the specified task's Task Queue when an interrupt occurs. Interrupts are not enabled by this call; a Thaw call must be used to enable interrupts.

Thaw

Task ID, Function Code and Device Mnemonic are the required fields.

This function enables interrupts on the specified TGD. The TGD is first checked to make sure that it is connected to the specified task. Once enabled, interrupts on this device may be disabled only by a Freeze or Unconnect call, or by the task going to EOT. This call has no effect if interrupts are already Thawed.

SINT

Task ID, Function Code and Device Mnemonic are the required fields.

This function simulates an interrupt on the specified TGD. The device must be connected to the specified task and it must be a SINTable TGD. (Not all TGD drivers are capable of accepting a SINT call; see Chapter 8). If device interrupts have not been enabled by means of a Thaw call, the SINT call is ignored. This condition is not treated as an error.

Freeze

Task ID, Function Code and Device Mnemonic are the required fields.

This function disables interrupts on the specified TGD. It does not disconnect the device from the task. Note that interrupts are not queued while the TGD is in a frozen state. This call has no effect if interrupts are already frozen.

Unconnect

Task ID, Function Code and Device Mnemonic are the required fields.

This function detaches the specified TGD from the specified task. If the device is in a Thawed state, its interrupts are disabled. The device is now free to be Connected to any other task.

Start Task Function

Task ID, Function Code and Start Address are the required fields. TT and Delay Time may optionally be specified.

This call causes the named task to be started. The address at which it is to be started is specified by the START ADDRESS parameter. If this field is non-zero, it indicates the address at which to start the task. If this field contains zero, the task is started at its established transfer address. If this field contains an address that is not within the specified task's memory, an error is returned by SVC 6.

This call is rejected if the specified task is not in a Dormant or Console Wait state. No implied-load facility is provided by this call; therefore, the specified task must be present in memory at the time of the call. It is permissible, of course, to specify both Load and Start functions in the same call, since the Start field is not processed until after the Load field processing is complete.

If Delay-Start is selected, the TT and DELAY TIME fields of the parameter block are used to determine the length and type of the delay. The specified task is actually started, but is placed immediately in a Time Wait or Interval Wait state.

This call is rejected if it is self-directed.

Sending and Receiving Task Messages

A task which is fully prepared to receive message(s) will have enabled queue entries on send requests from other tasks, and have set up a receiving buffer address in its UDL area. The task is not limited to one message buffer; it can set up a chain or ring of buffers so that a number of messages can be received.

Each receiving buffer must be 74 bytes long.

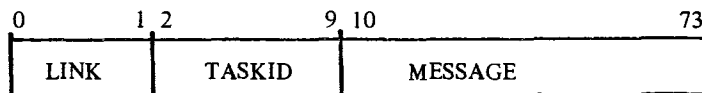

where, LINK is the link address (2 bytes) which points to next buffer or is zero to indicate last buffer in chain.

The least significant bit (i.e., X'0001') is used as a marker bit, since the true address is known to be even. This marker bit is:

1. Initialized zero by the task
2. Set by the system when a message is sent to indicate buffer full
3. Cleared by the task when the message is processed to indicate buffer empty

The TASKID field is an 8 byte Task Id of sending task and the MESSAGE field is a 64 byte message.

To receive messages a task must do the following.

1. Enable queue entries on send message by setting bit 11 in the current TSW. This enable bit is declared in the UDL STRUC (See Chapter 5) as:

TSW.PMM EQU X'0010' Queue Send Message

2. Set up a message buffer structure consisting of one or more 74 byte buffers. The address of the first buffer is declared in the UDL. This item is declared in the UDL STRUC as:

UDL.MSGR DS 2 A(Message Buffer)

Link addresses must also be set up at the beginning of each buffer.

The task can take a trap whenever a message is received. Task Queue Service Traps are enabled by Setting bit 4 in the current TSW. This enable bit is declared in the UDL STRUC as:

TSW.QSM EQU X'0800' Queue Service Trap Enable

On a send message request, the system first verifies that the receiving task is in the system and checks its current Task Status Word (TSW) to determine whether queue entry on send message is enabled. If not, it returns an error status. If enabled, the receiving buffer address is checked for being within the memory limits of the task. If zero (indicating no available buffer), or least significant bit is set (indicating the buffer is already full), or illegal, the system returns an error status.

If a buffer is available, the system stores the Task Id of the sending task in bytes 3 to 10, gets the message start address from the SVC parameter block, and moves 64 characters into bytes 10 to 73. The marker bit in the link address field is set to indicate that the buffer is full. The address of the buffer is added to the task's Task Queue, and the link address is placed in the receiving task's UDL to point to the next available buffer.

Message Buffer Structures

The mechanism for passing messages gives the receiving task a choice of Message Buffer Structures. Figure 3-3 outlines four possible structures.

Single-Buffer Ring

When the buffer is empty, the link field indicating the next message buffer points to itself, and the least significant marker bit is zero. When a message is received, the link field is moved into the UDL as A(MESSAGE RING) and the marker bit is set to 1. This inhibits further messages since the next buffer is already full. When the task has processed the message, it clears the marker bit to again enable the receiving of a message into the same buffer.

Single-Buffer Chain

Here the link field is zero to indicate no other buffers are available for the receiving of messages. On receipt of the first message, the zero link field is moved into the UDL, and will inhibit all subsequent messages. To enable messages, the receiving task must dynamically set up a new empty buffer address in the UDL.

Multiple-Buffer Ring

Initially all link fields indicate an empty buffer. When buffer 1 is filled, A(MESSAGE RING) is set to a point to buffer 2. When buffer 2 is filled, A(MESSAGE RING) is set to a point to buffer 1. If, by the time the next message is ready to be sent, buffer 1 has been processed by the receiving task, and the receiving task has set buffer 1 link field "empty", the message is placed in buffer 1. As long as the receiving task can process buffers as fast as they are being filled, no messages are lost and no "send message" requests are rejected. A multiple-buffer ring may consist of as many buffers as the user task desires. The link field of each buffer is set to point to the next buffer, that of the last buffer is set to point to the first.

Multiple-Buffer Chain

This structure is similar to that of the multiple-buffer ring, with the exception that the link field of the last buffer is set to zero. When the last buffer is filled by the system, A(MESSAGE RING) is set to zero, inhibiting the sending of further messages. This structure is of value if the receiving task is dynamically acquiring buffers from a pool within itself. Processed buffers are released from the chain and new buffers added to its end. If new buffers can be acquired as fast as the system fills them, no messages are lost.

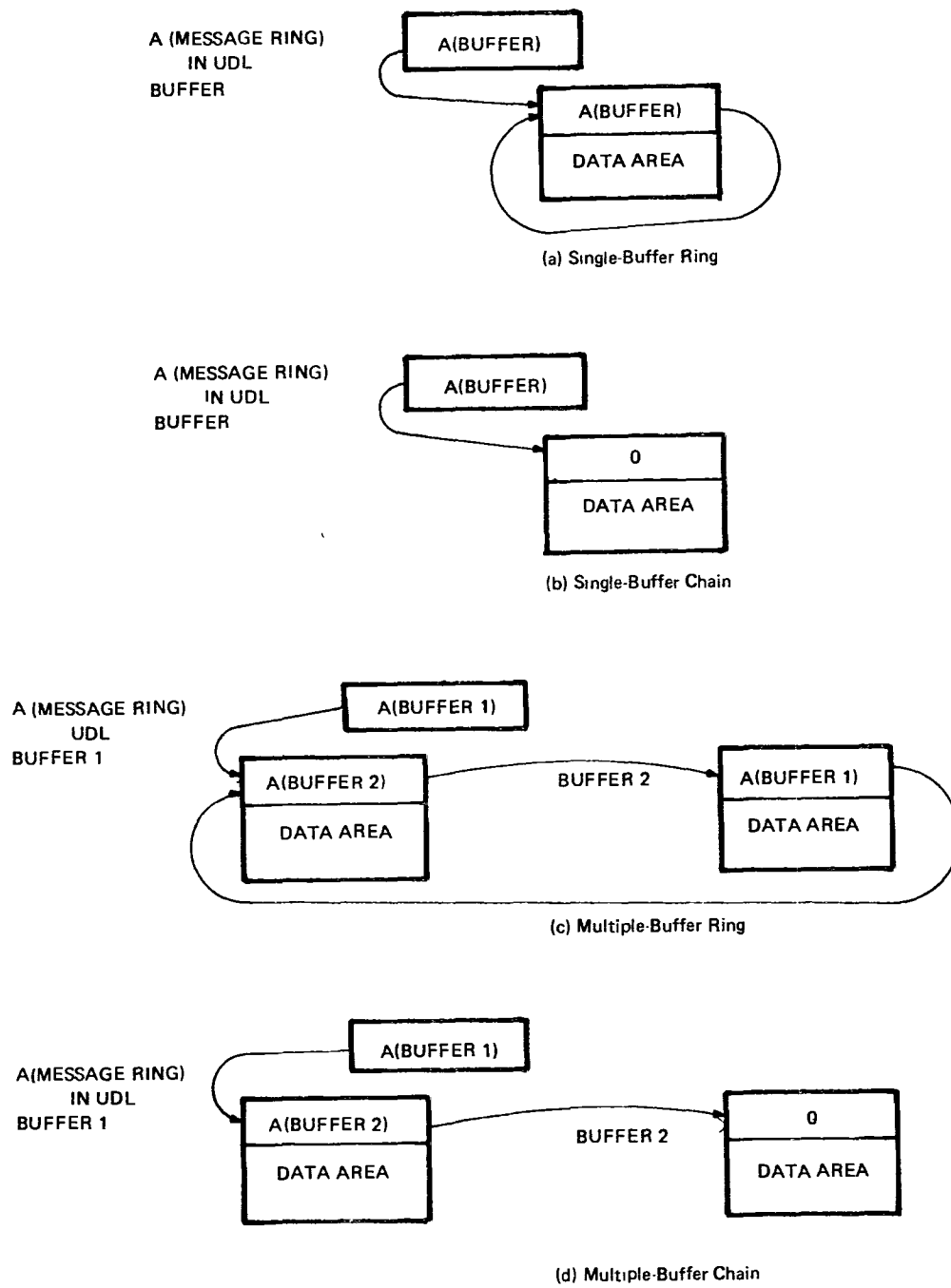

Figure 3-3. Message Buffer Structures

SVC 7 – FILE MANAGEMENT SERVICES

This call gives the user facilities for manipulation of files and devices. The facilities provided are:

- Allocation (creation) of direct-access files;
- Assignment of files and devices to Logical Units (LUs);
- Modification of access privileges on existing assignments;
- Renaming of files;
- Modification of files' protection keys;
- Closing (deassignment) of assigned files and devices;
- Deletion of direct-access files;
- Checkpointing of assigned files,
- Examination of attributes of assigned files and devices

The format of the SVC 7 Parameter Block, which must be on a halfword boundary in a writable logical segment is illustrated in Figure 3-4.

0(0)	CMD	1(1)	MOD	2(2)	STAT	3(3)	LU
4(4)	WKEY	5(5)	RKEY	6(6) LOGICAL RECORD LENGTH (LRECL)			
8(8) VOLUME ID OR DEVICE MNEMONIC							
12(C) FILENAME							
20(14) EXTENSION						23(17) (RESERVED)	
24(18) SIZE							

Figure 3-4. SVC 7 Parameter Block

The meaning and use of each field is explained in the description of each function requiring that field. The parameter block may be coded

PARBLK	ALIGN	2	
	DB	CMD	COMMAND
	DB	MOD	MODIFIER
	DB	0	STATUS
	DB	LU	LU
	DB	WKEY	WRITE KEY
	DB	RKEY	READ KEY
	DC	H'LRECL'	LOGICAL RECORD LENGTH
	DC	C'VOLN'	VOLUME
	DC	C'FILENAME'	FILE NAME
	DC	C'EXT'	EXTENSION
DC	Y'SIZE'	SIZE	

SVC 7 Parameter Block Fields

Command/Modifier

The format of the Command/Modifier Halfword is shown in Figure 3-5

BIT	0	1	2	3	4	5	6	7	8	10	11	12	13	15
NAME	A	O	H	N	P	C	D	T	AP		BM		FT	

COMMANDS			MODIFIERS
Bits	Name	Hex Mask	Meaning
0	A	8000	Allocate - requires file type (FT) modifier
1	O	4000	Assign - requires access privilege (AP) and buffer management (BM) modifiers
2	H	2000	Change Access Privilege - requires access privilege (AP) modifiers
3	N	1000	Rename - no modifiers
4	P	0800	Reprotect - no modifiers
5	C	0400	Close - no modifiers
6	D	0200	Delete - no modifiers
7	T	0100	Checkpoint - no modifiers
			Bits 0-7 all zero = Fetch Attributes (F)
8-10	AP		Access Privileges 0000
		0000	SRO - Shared Read Only
		0020	ERO - Exclusive Read Only
		0040	SWO - Shared Write Only
		0060	EWO - Exclusive Write Only
		0080	SRW - Shared Read-Write
		00A0	SREW - Shared Read-Exclusive Write
		00C0	ERSW - Exclusive Read-Shared Write
		00E0	ERW - Exclusive Read-Write
11-12	BM		Buffer Management
		0000	Default Buffer Management
		0008	Unbuffered (Physical)
		0010	Buffered (Logical)
		0018	Reserved
13-15	FT		File Type
		0000	Contiguous
		0001	Reserved (considered illegal)
		0002	Indexed
		0003	
		Reserved (considered illegal)
		0007	

Figure 3-5. SVC 7 Command/Modifier Halfword

Command

The Command bits are processed sequentially from left to right. If Bits 0-7 are all ZERO, a Fetch Attributes function is specified. The specific functions are described in the following paragraphs.

Access Privileges

Access privileges are necessary for Assign and Change Access Privilege calls. This field is ignored for all other functions. If Bits 8-10 are all ZERO, Shared Read Only (SRO) is specified.

Buffer Management

The default buffer management methods are Unbuffered for Contiguous File Type and Buffered for Indexed File Type. In OS/16 MT2, this field is ignored and the default is always used. For a Fetch Attributes call, the device code is returned to the Modifier byte of the Command/Modifier halfword.

Status

The interpretation of the status field depends on the functions specified in the call and is defined under the description of each command. A status of zero always means the desired options were performed without error. A summary of all possible error codes is given in Table 3-8 for reference.

TABLE 3-8. SVC 7 STATUS BYTE

ERROR CODE DEC (HEX)	FUNCTION	MEANING
0 (00)	ALL	No error, the requested functions are complete.
1 (01)	A,O,D	Illegal function, illegal file type
2 (02)	All but A,D	LU error; illegal LU
3 (03)	A,O,D	Volume error; no such volume/device in system
4 (04)	A,O,N,D	Name error; mismatch on filename or extension field.
5 (05)	A,O	Size error; erroneous LRECL or size field or no room on disc.
6 (06)	O,P,D	Protect error; erroneous protection keys.
7 (07)	All but C,T,F	Privilege error; unable to obtain requested privilege.
8 (08)	O	Buffer error; no room in system for file control blocks or buffers.
9 (09)	All but A	Assignment error, LU not assigned.
10 (0A)	A,O,N,P,D	Type error, non-direct access device, or device off-line.
11 (0B)	A,O,N,D	File Descriptor error; illegal syntax.
12 (0C)	O	Attempt to assign SVC 6 connectable device.
129-192 (81-C0)	All but F	I/O error; interpreted as SVC 1 status byte

The first error detected causes the SVC to return. If multiple functions were specified (e.g., Allocate and Assign) some functions may have been properly performed (always in left-to-right sequence).

LU Field

This byte defines the Logical Unit used for all the SVC 7 functions except Allocate and Delete

Write Key And Read Key

Protection keys for devices and Direct-Access files are specified in this halfword. These keys are required for the Allocate, Assign, Reprotect, and Delete functions. This field is used by the Fetch Attributes call to return the device or file attributes.

Logical Record Length (LRECL)

This halfword field, on an Allocate call, must contain the logical record length for a buffered file. On a Fetch Attributes call, the logical record length of a file or physical record length of a device is returned in this field. If ZERO is returned, device or file has a variable record length. LRECL is not used for other functions.

Volume ID (VOLN) or Device Mnemonic

This four-byte field identifies the volume if it is a Direct-Access file, or the device mnemonic if it is a device. This field of ASCII characters is required for the Allocate, Assign, and Delete.

VOLN together with FILENAME and EXT fields specify a File Descriptor. The volume name or device name, as the case may be, is returned by the system on a Fetch Attributes call in the VOLN field.

Filename

This eight-byte field identifies the file on a Direct-Access device; it is ignored for a device. The user must specify the filename in ASCII characters for Allocate, Assign, Rename, and Delete calls. The filename is returned by the system on a Fetch Attributes call; it is blank for a device.

Extension

This three-byte ASCII field identifies the file type (e.g., OBJ, TSK, CSS, etc.), on a Direct-Access file. It is treated as an extension of, and is required under the same conditions as, the FILENAME. The byte following this field is reserved for future expansion and is ignored.

Size

This fullword field, on the Allocate call, must contain the file size in sectors for a Contiguous file, or the data block size (Bits 0-15) and index block size (Bits 16-31), in sectors for an Indexed file. On a Fetch Attributes call, this field is used to return the current size of a file, or buffer size in bytes for a communications terminal; size is unchanged for a device. For an Indexed file, size is in number of logical records; for contiguous files, it is in number of sectors. For a Direct-access device (E-Task only) this field returns the number of sectors on the device.

SVC 7 Functions

Allocate

The Allocate function reserves space on a Direct-Access device and in the directory for the specified file type (FT). In the case of Indexed files, only a directory entry is reserved. The protection keys are entered in the directory. The required parameters are FT, KEYS, LRECL, VOLN, FILENAME, EXT and SIZE.

Applicable error codes are

1(01)	Illegal Function; an illegal file type was specified
3(03)	Volume Error, the specified volume was not mounted
4(04)	Name Error, the specified file name already exists on the specified volume
5(05)	Size Error; if a Contiguous file, there is not sufficient contiguous space on the specified volume to allocate a file of the specified size; if an Indexed file, there is insufficient space for a directory entry or invalid block size or logical record length specified.
7(07)	Privilege error; Disc is Write protected.
10(0A)	Type Error, the specified volume is not a Direct-Access volume.
11(0B)	File Descriptor Error; invalid syntax in volume name, file name or extension fields.
129-192 (81-C0)	I/O error

Assign

The Assign function establishes a logical connection between a file (or device) and the task through a specified Logical Unit, under a given access privilege (AP) and using a given Buffer Management (BM) technique. The call is processed as follows: First the access privilege is examined to determine which protect key to check. The proper key is then checked against the keys in the file directory. The BM field is checked to see if the specified Buffer Management technique is valid for the type of file being assigned. The file is then assigned according to the requested access privileges. If SWO or EWO (Write Only) is specified, the file is positioned at its logical end (records are appended). Otherwise, the file is positioned at the beginning (record number = zero). For devices, only the keys are checked, for the given access privilege.

The required parameters are AP, BM, LU, KEYS, VOLN, FILENAME and EXT; BM, FILENAME and EXT fields are not used for devices.

Applicable error codes are.

1(01)	Illegal function; attempt to assign invalid file type.
2(02)	LU Error; illegal LU
3(03)	Volume Error: no such volume, Direct-Access device specified for U-Task
4(04)	Name Error; no such name on given volume
5(05)	Size error; no room on disc to allocate an index and a data block
6(06)	Protect Error; mismatch on protection keys
7(07)	Privilege Error, requested privilege may not be granted
8(08)	Buffer Error, no room for FCB or buffer
9(09)	LU Already Assigned
10(0A)	Type Error; attempt to assign an off-line device to a U-Task.
11(0B)	File Descriptor syntax error.
12(0C)	Attempt to assign a Trap Generating Device (TGD)
129-192 (81-C0)	I/O Error

NOTE

A buffered file requires a buffer equal to the sum of the index and data block size of the file to be allocated in system space. The BM field is ignored in release 00 and 01; the default buffer management technique is used.

Change Access Privileges

This function allows the user to change the current access privileges of a file or device which is assigned. Only two parameter fields in the SVC 7 Parameter Block are required, the LU and AP portion of the modifier field.

If an error is encountered while processing this request, the file remains assigned with its original access privilege.

Applicable error codes are:

2(02)	LU Error, illegal LU
7(07)	Privilege Error; new privileges cannot be granted
9(09)	Assignment Error; LU not assigned
129-192 (81-C0)	I/O Error

Rename

This function permits the name of an assigned file to be changed. The file must currently be assigned to the specified Logical Unit for Exclusive Read-Write (ERW). The required parameters are LU, FILENAME and EXT. The given LU must be assigned to a direct-access file (unless the caller is an Executive Task which may rename devices). The volume name field of the parameter block is ignored. The specified FILENAME EXT replaces the previous FILENAME.EXT in the directory if the Rename function is successful.

Applicable error codes are:

2(02)	LU Error, illegal LU
4(04)	Name Error; new name already exists on given volume
7(07)	Privilege Error; file not assigned for ERW
9(09)	Assignment Error; LU not assigned
10(0A)	Type Error, LU assigned to a device (U-Task) or to the Null device (E-Task)
11(0B)	File Descriptor Error
129-192(81-C0)	I/O Error

Reprotect

This function permits the protection keys of an assigned file to be changed. The required parameters are KEYS and LU. The given LU must be assigned to a Direct-Access file for Exclusive Read-Write (ERW) (unless the caller is an E-Task which may modify the protection keys of devices). If either the specified Read key or Write key is equal to X'FF', that key is ignored rather than changed (unless the caller is an E-Task). If the call is rejected, the previous keys remain unchanged.

Applicable error codes are:

2(02)	LU Error; illegal LU
6(06)	Protect Error, current key has value X'FF' (U-Task only)
7(07)	Privilege Error; not assigned for ERW
9(09)	Assignment Error; LU not assigned
10(0A)	Type Error; LU assigned to a device (U-Task) or to the Null or console device (E-Task)
129-192(81-C0)	I/O Error

Close

This function discontinues an assigned logical connection between a task and a file or device. LU is the only required parameter. The specified LU is deassigned. Files or buffered communications devices assigned for Write access have any partially filled buffers, written out by the Close call. The Close function issues an SVC 1 Wait Only call to ensure that any previous I/O Proceed calls are complete before deassigning.

Applicable error codes are:

2(02)	LU Error; Illegal Logical Unit
9(09)	Assignment Error; LU not assigned
129-192(81-C0)	I/O Error

Delete

For a Delete function, the VOLN, FILENAME, EXT, and KEYS parameters must specify a Direct-Access file which is not currently assigned. If these conditions are met and both Read and Write keys match, the file is deleted from the directory of its volume. Only an E-Task may delete a file with a key of X'FF'.

Applicable error codes are:

1(01)	Illegal Function; attempt to delete invalid file type
3(03)	Volume Error; no such volume
4(04)	Name Error; file name does not exist on volume
6(06)	Protect Error; invalid protection keys
7(07)	Privilege Error; device write protected
9(09)	Assign Error; file currently assigned.
10(0A)	Type Error; attempt to delete a device.
11(0B)	File Descriptor Error
129-192(81-C0)	I/O Error

Checkpoint

The Checkpoint function permits the user to flush system Buffer Management buffers and to update the directory entry for a buffered file or communications device (e.g., BISYNC) on a given LU. LU is the only required parameter. Requesting a checkpoint for a non-buffered file or device has the same effect as an SVC 1 Wait Only call.

The user may wish to employ Checkpointing after sensitive data is added to a buffered file because the logical blocking of data in memory in system buffers leaves the file vulnerable. The integrity of the data can be preserved on the file by Checkpointing. In case of system failure, all data on Indexed files up to the latest Close or Checkpoint operation is recoverable; data appended after the most recent Checkpoint is lost. Checkpoint differs from a Close/Assign sequence in that no repositioning is performed and that filename, access privileges, and keys need not be specified.

The applicable error codes are:

2(02)	LU Error; illegal Logical Unit
9(09)	Assignment Error; LU not assigned
129-192(81-C0)	I/O Error

Fetch Attributes

Certain programs may require, for proper operation, knowledge of the physical attributes of the device or file associated with a given LU. For example, it might be desirable to know if random access is possible or if the device is rewindable. The Fetch Attributes function gives the user access to this information.

The applicable error codes are:

2(02)	LU Error; Illegal LU
9(09)	Assignment Error; LU Not Assigned

Various fields within the SVC 7 parameter block are redefined for this call. When the command field is set to zero, indicating a Fetch Attributes call, the only required parameter is the Logical Unit. The system returns information in fields KEYS, LRECL, VOLN, FILENAME, EXT, SIZE and Modifier byte.

The Write Key/Read Key halfword is redefined to receive an Attributes halfword as given in Table 3-9. Any bit set means the device or file supports the corresponding attributes.

TABLE 3-9. SVC 7 DEVICE ATTRIBUTES HALFWORD

BIT	ATTRIBUTES
0	Interactive device
1	Supports Read
2	Supports Write
3	Supports Binary
4	Supports Wait I/O
5	Supports Random
6	Supports Unconditional Proceed
7	Supports Image
8	Supports Halt I/O
9	Supports Rewind
10	Supports Backspace Record
11	Supports Forward Space Record
12	Supports Write Filemark
13	Supports Forward Space Filemark
14	Supports Backspace Filemark
15	Reserved

The LRECL field is set by the system to the physical record length associated with the device (e.g., 80 for a card reader, 120 or 132 for a line printer) if the record length is fixed; these two bytes are set to zero for a variable-record length device, (e.g., magnetic tape). A TTY or CRT, which is in the strict sense a variable-record length device, normally has LRECL set as though it were a fixed-record length device. This is because such a device is normally used in a fixed-record length method. Furthermore, a Contiguous Direct-Access file is considered to have a variable record length, whereas an Indexed file is considered to have a fixed record length, which is the logical record length specified for that file at the time of its allocation.

The volume name, file name, and extension (VOLN.FILENAME.EXT) for a named file, or the device mnemonic for a device is returned in the File Descriptor portion of the parameter block. The program may use this information to provide the operator with intelligent information in case of error, to generate the name of a new output file by transformation on the name of the input file, etc.

The current size of a Direct-Access file or current buffer size of a buffered communication device is returned in the SIZE field; SIZE is unchanged for devices. The number of logical records is returned for an Indexed file; the number of sectors is returned for a Contiguous file. These sizes are returned as unsigned hexadecimal numbers. The extended device code for a communications device is returned in the high order halfword of the SIZE field.

The Modifiers byte is set to indicate the file or device type. A sample of device codes is given in Table 3-10. The codes for all supported devices are given in Chapter 8.

Note that the full parameter block must be specified for the Fetch Attributes call or the system may overwrite the information following the parameter block.

TABLE 3-10. EXAMPLE DEVICE CODES

CODE DEC (HEX)	FILE OR DEVICE TYPE
0(0)	CONTIGUOUS FILE
2(2)	INDEXED FILE
16(10)	MODEL 33 TTY KEYBOARD/PRINTER
17(11)	MODEL 35 TTY KEYBOARD/PRINTER
18(12)	NONEDITING CRT ON CURRENT LOOP INTERFACE
34(22)	NONEDITING CRT ON LOCAL PASLA
36(24)	GRAPHIC DISPLAY TERMINAL ON LOCAL PASLA
49(31)	2.5 MBYTE REMOVABLE DISC CARTRIDGE
50(32)	10 MBYTE FIXED DISC CARTRIDGE
51(33)	10 MBYTE REMOVABLE DISC CARTRIDGE
52(34)	40 MBYTE REMOVABLE DISC CARTRIDGE
64(40)	800 BPI MAGNETIC TAPE
65(41)	1600 BPI MAGNETIC TAPE
66(42)	INTERTAPE CASSETTE
80(50)	HIGH SPEED PAPER TAPE READER/PUNCH
81(51)	MODEL 33 TTY READER/PUNCH
82(52)	MODEL 35 TTY READER/PUNCH
96(60)	CARD READER WITHOUT HOLLERITH/ASCII TRANSLATION
97(61)	CARD READER WITH HOLLERITH/ASCII TRANSLATION
112(70)	LOW SPEED LINE PRINTER
114(72)	HIGH SPEED LINE PRINTER
255(FF)	NULL DEVICE

SVC 9 – LOAD TSW

This call is used to return from task-handled traps, it is also used to change trap enable/disable bits, to change queue entry enable/disable bits, and to enter Trap Wait. This is the task analogue of the machine-level LPSW instruction.

The format of this call is:

SVC 9, A(X2)

The effective address of the SVC instruction specifies the location at which the new TSW is to be found on a halfword boundary in the task's address space.

The effect of this instruction is to replace the Current Task Status Word found in the task's TCB with the indicated Task Status Word. Unless Trap Wait is specified in the new TSW, the task resumes executing instructions at the address specified by the LOC field of the new TSW.

If the LOC field of the new TSW is zero, execution resumes at the instruction following the SVC 9.

CHAPTER 4

GUIDE TO USING SVC 2 FACILITIES

COMMAND PROCESSORS

Command processors are a part of almost all utility programs and of many applications programs. Every time a program is written that has to accept directions from the outside, either by conversation with an operator or by job-control statements read from an input device, a command processor is required to interpret those directions. Consequently, command processors are constantly being written and rewritten, tested and retested, yet most command processors are so similar to each other that one could generally be put together out of a package of "canned" routines, if such a package were at hand.

Some high-level languages, for example, SNOBOL, and certain versions of Extended BASIC, contain string-handling routines of sufficient sophistication as to render the writing of a command processor trivial. However, the assembly language programmer has no such facilities.

One of the earliest functions of operating systems was to simplify the writing of I/O handling code. A logical extension to this concept is the provision, within the operating system, of a simple and well-defined method of using the operating system's own command processing routines. The INTERDATA OS/16 MT2 Operating System provides such a method.

The user of this method may find that the command language of a program is constrained to the use of certain formats if the operating system's command processor calls are chosen. These calls provide such a great range of capabilities, and are capable of such flexible use, as to make a slight restriction in formatting negligible in cost when compared to the savings in design, code and debug time that are realized by the use of these calls.

This chapter gives the user a guide to the use of the calls provided in OS/16 for command processing functions.

COMMAND STATEMENT INPUT

The Command Statement may be read via SVC 1 from any Logical Unit, or may be passed from one task to another. The important issue is how the Command Statement is handled once it is in the buffer.

First, the buffer address is put into a given register. This register is used as the current buffer pointer during the entire command processing operation. All four command processing SVC 2 calls (Pack, Pack File Descriptor, Mnemonic Table Scan and Move ASCII Characters) expect to find the current buffer pointer in a register. The choice of which register to use is made by the user.

Mnemonic Scan

A Command Statement usually starts with some kind of mnemonic. This first mnemonic is generally called a *verb* because it tells what to do.

OS/16 provides a call, Mnemonic Table Scan, which may be used to look for a match on any table of mnemonics. These mnemonics must be all alphabetic characters, except for the first character, which may be any ASCII character. Thus, \$FRED is a valid mnemonic, but GLA2H is not. The mnemonic table is organized as a byte string. Each mnemonic in the table must be separated by one Null character (X'00') from the following mnemonic. The table is terminated by two Null characters in a row.

The OS/16 mnemonic syntax permits abbreviations. These are represented in the mnemonic table by flagging all required bytes of the mnemonic with Bit 0 set to a 1. Non-required bytes have Bit 0 set to 0. To represent the mnemonic APPEND, the code within the mnemonic table is:

DB	C'A'+X'80', C'P'+X'80'	required characters
DB	C'PEND'	non-required characters
DB	0	end of mnemonic

In order to match a mnemonic table entry, the command string must match all required characters. If more alphabetic characters are present in the command string, they must match the non-required characters. If all required and non-required characters are exhausted and there are still more alphabetic characters in the command string, no match is recognized.

For the example given previously, a legitimate match is found on

```

AP
APP
APPE
APPEN
APPEND
AP2          (scan terminates on first non-alphabetic after first character)

```

No match is found on:

```

A           (too short)
APPENG      (no match on non-required characters)
APPENDIX    (too long)

```

The mnemonic table scan routine terminates as soon as it finds a non-alphabetic character in the command string. If a valid match is found at this point, an index number indicating the position within the mnemonic table of the matched mnemonic is returned. If no match is found, the index number is returned set to -1. The system does not check the separator (the non-alphabetic character that terminated the scan routine). This character must be checked by the user. The buffer pointer that was given to the system is returned pointing to the separator, if a match was found; it is returned unchanged if no match was found. Entries in the mnemonic table are counted from ZERO, that is, if a match was found on the third mnemonic in the table, the index is returned with a value of 2.

The condition code 'V' bit is also set to show whether or not a match was found. It is set to 0 if there was a match, or to 1 (CC=4) if there was no match.

A sample of how to use the Mnemonic Table Scan routine follows. Assume that the mnemonic table is to consist of four entries: SORT, MERGE, Print, and STOP. This table is coded as follows:

```

MNMNTAB    DB  C'S'+X'80',C'O'+X'80',C'RT',0
              DB  C'M'+X'80',C'E'+X'80',C'RGE',0
              DB  C'P'+X'80',C'R'+X'80',C'INT',0
              DB  C'S'+X'80',C'T'+X'80',C'OP',0,0

```

Notice the two bytes of ZERO ending the mnemonic table. If the command buffer pointer is found in register PNTR and the index is to be returned in register INDX, an SVC 2 parameter block to handle this table is coded as follows:

```

SCAN       DB  0,17,PNTR,INDX
           DC  A(MNMNTAB)

```

Assume that a command line has just been read into a buffer named CMDBUF. The verb is found as follows.

```

FNDVB      LDAI      PNTR,CMDBUF          set up buffer pointer
           SVC       2,SCAN              scan the table
           BO        CMDERR              branch if no match
           SLLS     INDX,LADC            prepare for indexed branch
           LDA      INDX,JTAB(INDX)     get jump table address
           BR       INDX                 go to command executor

JTAB       DAC      SORT, MERGE, PRINT, STOP

```

This routine did not check the separator; if the characters SORT* had been in the command buffer, the result would have been the same as if SORT (Carriage Return) had been the command buffer content. Using this information, the code can be modified by taking advantage of the fact that PNTR points to the separator after a valid match. Assume that only a Carriage Return is allowed to follow the verb:

```

FINDVB     LDAI      PNTR,CMDBUF
           SVC       2,SCAN
           SLLS     INDX,LADC
           BM       CMDERR
           LIS      WORK,X'0D'          another way to test for error
           CLB      WORK,0(PNTR)       pick up a carriage return
           BNE     CMDERR               check the separator
           LDA      INDX,JTAB(INDX)
           BR       INDX

```

The results are better. If different separators are required for different verbs, however, the separator check should be done after the jump table branch. If no match is found, PNTR is not changed. If the proper mnemonic is not found, consult a different mnemonic table. The verb, in this particular syntax, may be optional and therefore has a default value. For example, in BASIC the verb is optional and defaults to LET.

Operand Decoding

Most command languages require operands for most of their verbs. The verb tells the processor what to do, the operands tell what to do it to, or how to do it. Operands in OS/16 MT2 command processor syntax are

- Decimal numbers up to 65,535
- Hexadecimal numbers up to FFFF
- File Descriptors
- Mnemonics
- Arbitrary ASCII strings

These are sufficient for most needs. If other forms of modifiers are required, they may be decoded by the user.

Decimal and Hexadecimal Numbers

The OS/16 MT2 Pack Numeric Data call allows decimal and hexadecimal numbers to be decoded. Options are provided either to skip, or not to skip, leading blanks. The current buffer pointer is required; this may be in the same register that was used for the MNEMONIC TABLE SCAN call. The result is always returned in Register 0. This call sets the Condition Code to indicate the status of the call. If too many digits were found, the 'V' flag is set (CC=4); if no digits were found, the L flag is set (CC=1). The first nontranslatable character found terminates the operation, and PNTR is set to point to that character, so that the separator can be checked easily.

The parameter block looks like one of the following (depending on options)

PACKDEC	DB	X'80',15,0,PNTR	decimal
PACKHEX	DB	0,15,0,PNTR	hexadecimal
PACKDECS	DB	X'C0',15,0,PNTR	decimal, skip leading blanks
PACKHEXS	DB	X'40',15,0,PNTR	hexadecimal, skip leading blanks

Assume that the syntax of the rewind command were as follows

```
<rwcmd> ::= REWIND <lu>
<lu> ::= <decimal number less than 256>
```

And assume that the verb finder had found a match on REWIND and now wishes to find <lu>. This is done as follows.

REWIND	SVC	2,PACKDECS	get decimal number, skip blanks
	BO	CMDERR	error if too many digits
	BM	CMDERR	error if no digits
	CLHI	R0,256	
	BNL	CMDERR	error if number is too big
	LIS	WORK,X'0D'	check for carriage return
	CLB	WORK,0(PNTR)	
	BNE	CMDERR	
	STB	R0,RWDPBLK+1	
	SVC	1,RWDPBLK	rewind the lu
		continue

Before stipulating "skip leading blanks", the number of leading blanks in the buffer must be considered, as the buffer may contain all blanks. The following resolves this problem:

SVC	2,PACKDECS
CLAI	PNTR,BUFFEND
BNL	CMDERR

Another problem is now encountered assume that <lu> were optional, with a default of ZERO. In that case, the BM CMDERR instruction should be omitted since the Pack call sets Register 0 to ZERO if no digits are found.

File Descriptors

This section does not apply to programs which do not perform any file or device handling; however, for systems using LU instead of device, this section points out the advantages of file and device handling. Under OS/16 MT2 it is easier to handle device and file names than it is to handle simple decimal numbers, because the system can do more error checking and default processing.

The Pack File Descriptor call is used to handle device or file names.

When Pack File Descriptor is called, it expedites decoding the entire syntax, including file name, volume name, extension, and separators, handles the optional cases and flags them; and expedites handling one common default case. The format of the parameter block is:

PACKFD	DB DC	0,16,0,PNTR A(SV7PB+8)	ordinary call
PACKFDS	DB DC	X'40',17,0,PNTR A(SV7PB+8)	skip leading blanks
PACKFDN	DB DC	X'80',16,0,PNTR A(SV7PB+8)	no volume default
PACKFDNS	DB DC	X'C0',16,0,PNTR A(SV7PB+8)	no default, skip blanks

As an example of how this call may be used, the syntax of the rewind command may be changed to:

```
<rwdcmd> ::= REWIND <fd>
```

A valid processing routine is:

REWIND	SVC BO CLAI BNL SVC SVC SVC	2,PACKFDS CMDERR PNTR,BUFFEND CMDERR 7,SV7PB 1,RWD 7,CLOS0	pack fd and skip leading blanks branch on syntax error error if scan past end of buffer open the device or file on LU 0 rewind the device close LU 0 continue
SV7PB	DB DC DS	X'40',0,0,0 Y'0' 16	open LU 0 File Descriptor field
CLOS0	DB	X'04',0,0,0	close LU 0
RWD	DB	X'C0',0,0,0	rewind LU 0

In this example, SVC 1 or SVC 7 calls were not checked for errors, since the purpose of this demonstration does not concern use of SVC 1 or 7. A more difficult example is:

```
<inputcmd> ::= INPUT <fd>
```

where the default volume name must be FRED and the default extension must be OBJ. Assume the verb INPUT has been detected and that the separator has not yet been checked.

WORK	EQU	14	
INPUT	LB CLHI BNE AIS LM STM SVC BO BNC LM STM	WORK,0(PNTR) WORK,C' CMDERR PNTR,1 WORK,VOL WORK,SV7PB+8 2,PACKFDN CMDERR PROCESS WORK,EXT WORK,SV7PB+20	check separator separator ok, increment pointer setup default volume pack fd, no skip, no default branch on syntax error branch unless default extension setup default extension
PROCESS		continue
VOL	DC	C'FRED'	
EXT	DC	C'OBJ'	

The default volume name, FRED, was stored in the receiving area before the SVC 2 call. If the command string contained a volume name, FRED is overlaid. If no volume name was present in the command string, since "no default" was specified, the volume name field of the receiving area is left unchanged. The extension default must be handled following an SVC 2 call

The "no default" option is explained as follows: In any OS/16 MT2 system that has Direct-Access storage, there is a volume called the system default volume. This volume name may be changed by the console operator. Most commands to OS/16 MT2 itself assume that if no volume name is specified, the default volume is assumed. Therefore, the normal call to Pack File Descriptor stipulates default volume. If no volume ID is present in the File Descriptor string, OS/16 MT2 returns the name of the default volume, whatever it may be at the time, as though the user had typed it in.

The reason for the no-default option is now clear. There are instances when the program may not wish to default to the name of the default volume, but rather to the last volume name that the user did type in, or perhaps to a volume name that the program specifically set up. If the program specifies no-default, the Pack File Descriptor routine assumes that the program has already set up the volume field of the receiving area for default condition. If the user does not enter a volume ID and the program has specified no-default, the volume field of the receiving area is left unchanged.

The address field of the sample parameter block is defined as A(SV7PB+8). This is because, when the PACK FILE DESCRIPTOR is called, the program desires the receiving area to be the File Descriptor field of an SVC 7 parameter block. This area is located 8 bytes past the start of the SVC 7 parameter block. It is not necessary to move the data directly into a parameter block. Note, however, that the receiving area must be 16 bytes long and must begin on a halfword boundary.

This call sets condition codes. The 'V' flag (CC=4) denotes a syntax error. The 'L' flag (CC=1) denotes no volume ID. This flag is set whether or not no-default is specified. The 'C' flag (CC=8) denotes no extension. If no extension is found, the system automatically gives a default extension of blanks. If use of a different default extension is desired, for example, OBJ, the 'C' flag tells when to use it. If the blank extension is satisfactory as a default, the 'C' flag may be ignored. The 'V' flag should never be ignored, since the receiving area is undefined following a syntax error.

Following a syntax error, the command string pointer is returned unchanged.

Further Mnemonics

Operands within a command may take the form of mnemonics, just as the verb did. These mnemonics are processed in the same way as the verb. Abbreviations may be used. The call to Mnemonic Table Scan is performed in the same way. Normally, a separate mnemonic table is used, however, it is possible to use the same mnemonic table that was used to find the verb.

Notice that there is no provision in the call to Mnemonic Table Scan for the skipping of leading blanks. This means that the program has to perform this function, if it is desired. Also note that register PNTR must be pointing at the first character of the mnemonic to be scanned. This means that PNTR must be adjusted to skip the separator that followed the preceding verb or operand.

ASCII Strings

Even with all the facilities described previously, there are times when an operand does not quite fit any of the normal categories (Hexadecimal or Decimal numbers, File Descriptors, or mnemonics). OS/16 MT2 provides a call to meet these contingencies. This is the Move ASCII Characters call. This call should cover any special cases that cannot be handled by one of the normal calls. It has two options. One is used when a fixed number of characters must be moved from the command string to a receiving area. This number of characters may not exceed 127. The format of the parameter block for this option is:

```
MOVEF          DB          N,18,PNTR,OUTPTR
```

The number of characters to be moved is indicated by N. PNTR is the current buffer pointer, as in all the preceding calls. OUTPTR is a register that holds a pointer to the location of the characters' placement. After the data is moved, OUTPTR is adjusted to point one byte beyond the last character moved.

The second option is considerably more complex. This option is used when a variable number of characters, terminated by some separator, is to be moved. In this case, the parameter block is:

```
MOVEV          DB          X'80'+N,18,PNTR,OUTPTR  
                DAC          SEPSTR
```

The maximum number of characters to be moved is indicated by N. PNTR and OUTPTR are the current buffer pointer registers. SEPSTR is the address of a string of separators. When any of the separators in this string is found in the command string, the move operation is terminated. If none of the separators is found, the move operation terminates when the maximum number of characters (N) has been moved. The Condition Code V flag is set (CC=4) to show that no separator has been found. The separator string is coded as follows:

```
SEPSTR          DB          NUM,SEP1,SEP2,SEP3,...
```

where NUM is the number of separators in the string and SEP1, SEP2, etc., are the actual separators. For example, if the program wishes the move operation to terminate, if the character * or the character \$ were found, the separator string appears as follows

```
SEPSTR          DB          2,C'*$'
```

A more possible example depicts the characters (blank), CR (carriage return), , (comma), or ; (semicolon) as valid separators. In this case, the separator string appears as:

```
SEPSTR          DB          4,C' ,;X'0D'
```

The calling method is as follows

LDAl	OUTPTR,OUTBUFF	output buffer address to register OUTPTR
SVC	2,MOVEV	move variable number of characters
BO	NOSEPS	branch if no separator
...		continue

CHAPTER 5

GUIDE TO TASK-HANDLED TRAPS

INTRODUCTION

A complete OS/16 MT2 system encompasses a 16-Bit Processor, the OS/16 MT2 operating system, and a set of tasks. This section explores the makeup of a task at the task block structure level. A thorough discussion of the writing of the code contained in the executable task structures is beyond the scope of this section. For such information the reader is referred to:

16-Bit Series Reference Manual
Chapters 2 and 3 of this manual
Common Assembly Language Users Manual

The FORTRAN user should refer to the *FORTRAN V Level II User's Manual* for information on representing the various task structures described here in the FORTRAN language.

This section also describes in detail the construction of task data structures using system STRUCS supplied with OS/16 MT2. Examples are given for structures referred to in this section as well as general uses of system STRUCS.

The various steps required to prepare a task for execution are also outlined.

TASK STRUCTURE

A task in OS/16 MT2 contains code to do the work of the task (Mainline Code), a set of User Dedicated Locations (UDL), and an initial Task Status Word (TSW). Any program, including a standard utility, that is to be run as a task under MT2, can be ignorant of its UDL and TSW since TET/16, which establishes it as a task, leaves the appropriate amount of space in its image output for the UDL and supplies an appropriate default for the initial TSW.

In addition to the UDL, TSW, and mainline code that a simple task might contain, the various features provided in MT2 require additional task components. It should be understood that each additional component is only required to be included in the task if the MT2 facility it supports is to be used. The potential components of a task are as follows:

- Task Status Word (other than default)
- User Dedicated Locations
- Mainline Code
- Task Queue
- Task Queue Trap Service Routine
- Power Restoration Trap Service Routine

The following discussions of each component indicate which OS facilities are involved and, therefore, which task components are to be included when writing the task during the task's design process. Figure 5-3, at the end of this section, summarizes which task components are required for various OS facilities.

Task Status Word (TSW)

The Task Status Word (TSW) describes the state of a task at any one time with respect to user controlled interaction with the operating system. The various task traps, as well as the different reasons for additions to the task's Task Queue are controlled through the task's TSW. This status word is used to enable or disable the various task traps, enable or disable additions to the Task Queue from various sources and contains the location counter and condition code upon taking and returning from task traps. TSW bit assignments are shown in Figure 5-1.

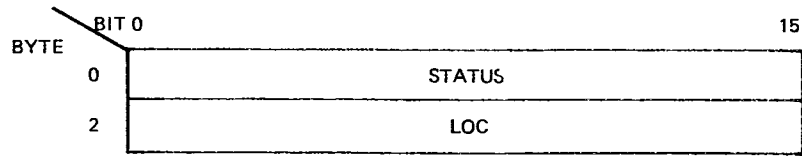

TASK STATUS WORD IS 32-BITS THE FIRST HALF WORD (BITS 0-15) CONTAINS STATUS DEFINED IN FIGURE 5-1. SECOND HALF WORD (BITS 16-31) CONTAINS THE CURRENT LOCATION COUNTER AS IN A P. W.

STATUS BITS			
BIT	HEX MASK	NAME	DESCRIPTION
0	8000	W	TRAP WAIT – TASK SUSPENDED UNTIL A TASK TRAP OCCURS
1	4000	P	POWER RESTORATION TRAP ENABLE – A TASK TRAP OCCURS ON COMPLETION OF SYSTEM POWER RESTORE SEQUENCE
2-3			RESERVED – MUST BE ZERO.
4	0800	Q	TASK QUEUE SERVICE TRAP ENABLE – A TASK TRAP OCCURS WHEN AN ITEM IS ADDED TO THE TASK QUEUE. ALSO A TRAP OCCURS IF A TSW IS LOADED WITH THIS BIT SET AND THE TASK QUEUE IS NOT EMPTY.
5			RESERVED – MUST BE ZERO
6	0200	O	ENABLE TASK QUEUE ENTRY ON INTERRUPT FROM A CONNECTED TRAP GENERATING DEVICE.
7	0100	T	ENABLE TASK QUEUE ENTRY ON QUEUE PARAMETER (SVC 6) REQUEST DIRECTED AT THIS TASK.
8	0080	Z	ENABLE TASK QUEUE ENTRY ON COMPLETION OF A TIME INTERVAL.
9	0040	O	ENABLE TASK QUEUE ENTRY ON COMPLETION OF I/O PROCESS REQUEST.
10			RESERVED
11	0010	E	ENABLE TASK QUEUE ENTRY ON SEND MESSAGE
12-15	000F	CC	CONDITION CODE (AS IN PSW).

Figure 5-1. Task Status Word (TSW)

The task has a current TSW at all times. The initial TSW of the task (the current TSW upon loading the task) is set at Task Establishment time. At that time a specific Initial TSW may be set; otherwise, the initial TSW defaults to zero (no traps or queue entries enabled), plus a location counter of the starting address specified at assembly time (argument of the END assembly statement) or, if unspecified, the start of the task code.

When a task trap occurs (that is, when a trap causing condition occurs while the particular trap is enabled in the current TSW) the current TSW is saved in the appropriate area of the User Dedicated Locations (UDL) and a new TSW is loaded from the appropriate area of the UDL. The new TSW controls the traps or task queue entries that are to be allowed during the execution of the trap service routine.

A task may change its current TSW at any time by executing an SVC 9 load TSW. The argument address of the SVC 9 call points to a four byte area aligned on a halfword boundary, containing the new TSW to be loaded.

The first two bytes contain the status and the next two contain the location counter of the TSW. Following SVC 9 processing, the task resumes execution at the location specified in the loaded TSW. If only the status of the current TSW is to be changed, without affecting the flow of execution of the task, a zero location counter should be specified in the new TSW. In this case, execution resumes at the instruction following the SVC 9 call.

If an SVC 9 call loads a TSW enabling a task trap that is capable of occurring immediately (e.g., enabling Task Queue Service Trap while the Task Queue is not empty), a TSW swap occurs, storing the just loaded TSW in the UDL and loading a new TSW from the UDL.

Also, an SVC 9 load of a TSW enabling Trap Wait places the task in Trap Wait, suspending execution until one of the traps enabled in the same TSW occurs. Since execution never resumes with the Trap Wait bit set, the location counter portion of such a TSW is ignored.

NOTE

If a task is in Trap Wait with no task traps enabled, it will wait indefinitely or until it is cancelled.

User Dedicated Locations (UDL)

A task's UDL starts at the first location within its partition. It contains Task Status Word (TSW) swap areas and other data used for communication between the operating system and the task, as follows (refer to Figure 5-2). Items in parentheses are the names of the relevant fields in the UDL STRUC, to be discussed later:

CTOP (UDL.CTOP)	Contains the program address of the highest halfword in the task's allocated memory.
COMBOT (UDL.CBOT)	Contains same address as CTOP. Provided for compatibility with older 16-Bit Operating Systems.
UTOP (UDL.UTOP)	Contains the program address of the first halfword following the user's program.
UBOT (UDL.UBOT)	Contains the program address of the bottom of the user's program.
Power Restore Old TSW (UDL.PWRO)	Set by the operating system to the task's current TSW on occurrence of a Power Restoration Trap.
Power Restore New TSW (UDL.PWRN)	Set by the user to the TSW to be loaded on the occurrence of a Power Restoration Trap. The LOC portion of this TSW points to a Power Restoration service routine.
Task Queue Service Old TSW (UDL.TSKO)	Set by the operating system to the task's current TSW on occurrence of a Task Queue Service Trap. A Task Queue Service trap occurs when task queue service trap is enabled in the current TSW and the Task Queue is non-empty.
Task Queue Service New TSW (UDL.TSKN)	Set by the user to the TSW to be loaded on the occurrence of a Task Queue service trap. The LOC portion of this TSW contains the address of a Task Queue service routine.
A (Task Queue) (UDL.TSQ)	Set by the user to the address of the task's Task Queue. This location must be set prior to enabling any entries to the Task Queue. If the contents of this location is zero, no task queue entries are made regardless of the state of the Task Status Word's queue entry enabling bits (TSW.DIQM, TSW.TCM, TSW.IOM, TSW.TMCM).
A (Message Buffer) (UDL.MSGR)	Set by the user to the address of the first (or only) message buffer, if messages are to be received from another task in the system. If this item is zero, no messages can be received.

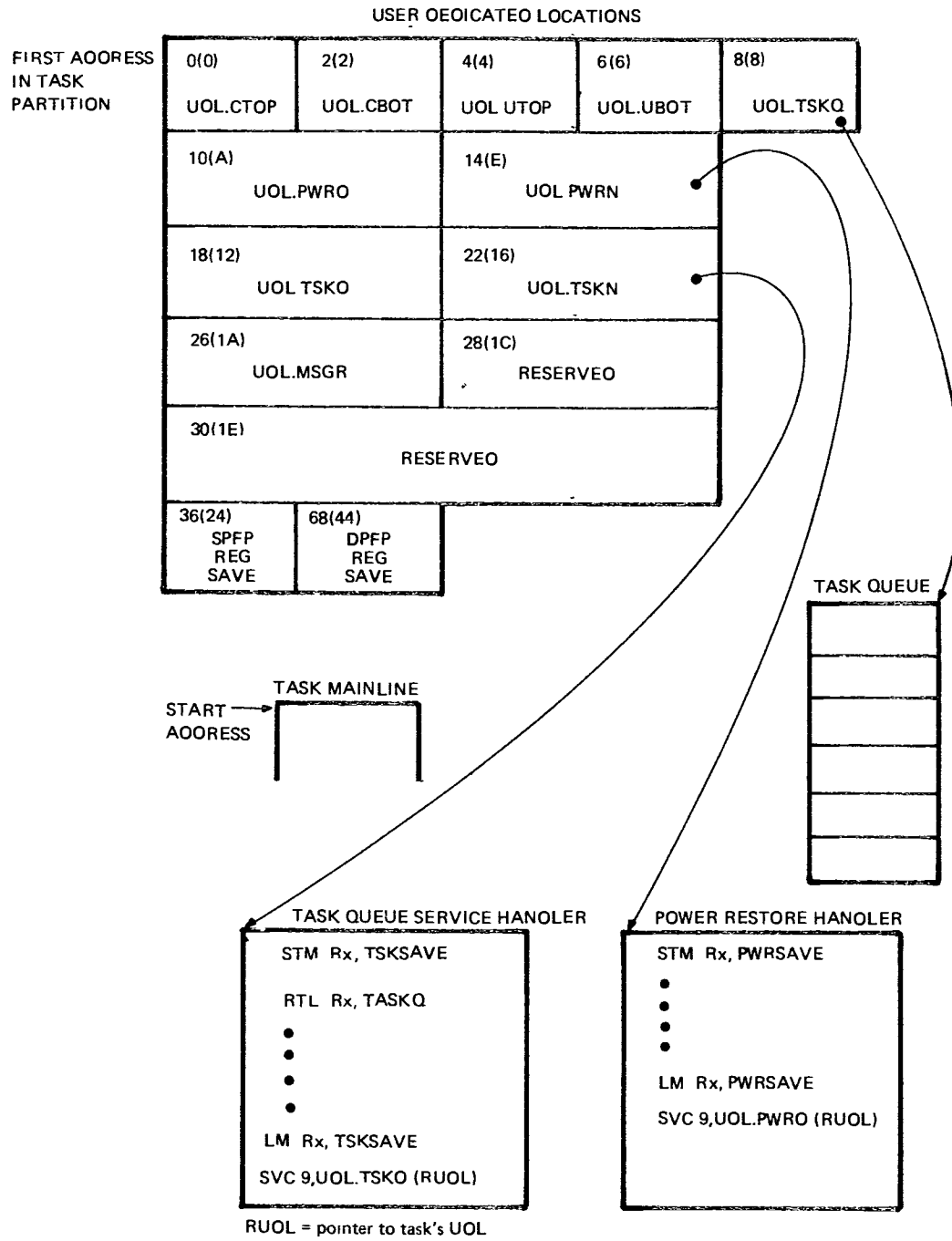

Figure 5-2. Task Structure

For the user supplied fields in the UDL (UDL.TSKQ, UDL.PWRN, UDL.TSKN, UDL.MSGR) there is a choice between assembling the UDL containing these fields as constants or loading these fields during the task initialization phase. After a program is assembled into object code, it must be established as a task with TET/16

If a task includes an assembled UDL, the command OPTION NOUDL must be passed to TET/16 at task establishment, so that TET/16 does not reserve a UDL area on behalf of the task

If a task sets up its UDL area dynamically at run-time, no special OPTION command is necessary. TET/16 automatically reserves and initializes the UDL to zero; 132 bytes if OPTION DFLOAT is specified, 68 bytes if OPTION FLOAT is specified, or 36 bytes if no floating point support is required.

Mainline Code

If the task is an autonomous program with no need of the task trap features of OS/16 MT2, the mainline code consists of the original program that is being run as a task. Together with its UDL, it is a complete task

However, when the task makes use of the task trap features of the OS, the exact function of the mainline code is a basic design choice. Mainline task code can be nothing more than a short start-up routine with all the work of the task being done in trap service routines or it can perform the bulk of the work with only small amounts of work done in the service routines. The particular design depends on the task's application.

-

Task Queue

The operating system uses the Task Queue to inform a task of the occurrence of the events shown in Table 5-1. A Queue is used so that entries (referred to as items) resulting from events are not lost during the time the task is servicing a previous item. A Task Queue is formed by the assembly language statements:

```
label  DB n,0,0,0
        DS n*2
```

Operand 'n' is the size (number of items capacity) of the queue, and label is used as the address of the Task Queue. UDL.TSKQ, in the UDL, must be set to this address before entries can be made to the Task Queue (see Figure 5-2). No specific advice is given for the size of the queue since this decision depends on the task's application and expected frequency of occurrence of queue-related events compared to the individual event service time. In general, if a queue related event occurs when the queue is full, the associated item is lost. Therefore, the following guidelines should be used in determining a *minimum* queue size:

```
1 entry for each device capable of interrupting concurrently
n entries for each task capable of queueing n parameters concurrently
1 entry for each Logical Unit having concurrent I/O proceeds
1 entry if a time interval trap is to be scheduled (SVC 2 code 23)
m entries for each task capable of sending m messages concurrently
```

A Task Queue Service Trap occurs whenever the Task Queue Service Trap enable bit (Bit 4, symbol TSW.TSKM) is set in the current TSW *and* the Task Queue is non-empty (i.e., has at least one item in it). Items are added to the queue only if the particular queue entry enabling bit is set in the current TSW (shown in Table 5-1).

The Task Queue is a standard INTERDATA 16-Bit Series circular list (refer to the *16-Bit Processor User's Manual*, Chapter 3, for a detailed description). The operating system adds items to the bottom of the queue, therefore, the task would typically remove items for servicing from the top of the queue. For example:

```
RTL R1,TASKQ
```

(an item is removed from the top of the Task Queue at TASKQ and placed in register R1 for examination/processing).

The user can use the ABL machine instruction to add simulated items to the queue before enabling Task Queue Service Traps, thereby simulating a Task Queue Service Trap, perhaps to start off a cycle of I/O Proceeds.

Resident Tasks that are to be cancelled and restarted by other tasks should initialize their Task Queues to an empty state each time they are restarted to prevent old queue items from causing erroneous behavior by the task. An example of code to initialize a Task Queue at address TASKQ is:

```
LIS    RF,0
STB    RF,TASKQ+1
STH    RF,TASKQ+2
```

TABLE 5-1. TASK QUEUE ITEMS

SOURCE	QUEUE ENTRY ENABLING BIT*	CONTENTS OF ITEM
Device Interrupt	X'0200' (TSW.OIQM) *	Parameter associated with device
SVC 6 Queue Parameter	X'0100' (TSW.TCM) *	Parameter specified in call
Timer Termination	X'0080' (TSW.TMCM) *	Parameter specified in call
I/O Proceed Completion	X'0040' (TSW.IOM) *	Address of SVC 1 Parameter Block
Task message Received	X'0010' (TSW.PMM) *	Address of message buffer

* The name in parentheses is the symbolic name of the mask used to enable the associated bit (to be discussed later).

Task Trap Service Routines

A Task Trap occurs when a particular Task Trap is enabled in the current TSW at the time of a trap causing event. Table 5-2 gives the types of Task Traps, enabling bit in the current TSW, and Trap Causing event.

TABLE 5-2. TASK TRAPS

TASK TRAP	ENABLING BIT*	EVENT
Power Restoration	X'4000' (TSW.PWRM) *	System Power Restoration
Task Queue Service	X'0800' (TSW.TSKM) *	Task Queue Non-Empty

* The name in parentheses is the symbolic name of the mask used to enable the associated bit.

A trap service routine must be written and included in the task for each task trap to be used. Prior to enabling the Task Trap, the TSW swap area in the UDL for that trap must contain a new TSW for that trap (see Figure 5-2). The status portion of the new TSW is the Task Status to be in effect during the execution of the trap service routine; the location counter portion is the entry address of the trap service routine. Care must be exercised in enabling any Task Traps in the new TSW status of a particular Task Trap. (If two Trap Service routines, A and B, enabled each other's Trap and Trap A occurred, Trap B might occur enabling Trap A again and if Trap A occurs, the first old TSW for Trap A would be lost.)

Since a Task Trap may occur during execution of code elsewhere in the task it is the responsibility of each Task Trap service routine to save any registers it uses to avoid disturbing the interrupted code.

Task Queue Service Routine

This user written routine is entered upon a Task Queue Service Trap (i.e., whenever Task Queue service is enabled in the current TSW and the Task Queue is non-empty). The Task Queue Service new TSW field of the UDL (that is, the TSW in effect during Queue Service) typically has a status disabling Task Queue Service (if enabled, the Task Queue Service routine could interrupt and reenter itself with dubious consequences) but enabling various queue entries to continue while the trap-causing item is serviced.

Table 5-1 shows the five types of events that can cause items to be added to the task queue. Each item is 2 bytes in length with the content dependent on the particular item as follows:

Device Interrupt The item is the parameter specified at the time the Trap-Generating Device was CONNECTed (via SVC 6) to the Task.

SVC 6 Queue Parameter: The item is the parameter specified in SVC 6 parameter block causing a parameter to be queued to this task.

I/O Proceed Completion The address of the SVC 1 parameter block of a completed I/O proceed.

Interval Completion Termination: The item is the parameter specified in the SVC 2 code 23 which caused the Timer Termination.

Task Message Received: The item is the address of the message buffer

The item is removed from the Task Queue with an RTL instruction. After the trap-causing item is decoded and the appropriate action taken, the Task Queue Service routine typically exits with an:

SVC 9,UDL.TSKO(RUDL)

where UDL.TSKO is the symbolic name of the UDL Task Queue Service old TSW save area (to be discussed later) and RUDL is a pointer to the task's UDL. By loading the old TSW in this way, execution resumes at the location, with the status in effect, at the time the task was trapped. If additional items are on the Task Queue, loading the old TSW causes the Task Queue Service trap to recur for service of the additional items.

Power Restoration Trap Service Routine

This user written routine is entered upon a Power Restoration Trap (whenever Power Restoration trap is enabled in the current TSW and a system power restoration takes place, note that if the Power Restoration Trap is disabled at the time of a system power restoration, the task is PAUSED. Once this routine is entered, it can go about the business of recovering the task from the power outage (highly application dependent), and if it determines the situation warrants resumption of the task, the routine exits with:

SVC 9,UDL.PWRO(RUDL)

Figure 5-3 summarizes task requirements.

OS FACILITY \ REQUIRES	NON-ZERO TSW	UDL	TASK QUEUE	TASK QUEUE SERVICE RTN.	PWR RESTORE SERVICE RTN.	MESSAGE BUFFER
SVC 2 CODE 5 FETCH POINTER		X				
RECEIVING SVC 6 QUEUE PARAMETERS	X	X	X	X		
RECEIVING PARAMETER ON OEVIC INTERRUPT	X	X	X	X		
RECEIVING PARAMETER ON TIMER COMPLETION	X	X	X	X		
RECEIVING PARAMETER ON I/O PROCEED COMPLETION	X	X	X	X		
RECEIVING MESSAGE	X	X	X	X		X
POWER RESTORATION TRAP	X	X			X	

Figure 5-3. Task Requirements Summary

OS/16 MT2 SYMBOLS AND STRUCS

The CAL Assembler provides a powerful facility for referencing, by name, numerical constants and constant displacements within a data structure (STRUCs) (refer to the CAL User's Manual, for detailed syntactical description of STRUCs). A reference made in such a way is said to refer symbolically to a constant (or constant displacement).

Symbolic references are generally much easier to use than their numeric counterparts because of the ease in remembering a name. Errors involving references are less likely since using an inaccurate numerical constant is usually assembled without an error while using an inaccurate symbolic name is caught by the assembler (as an undefined symbol). Symbolic references help make assembly language code easier to read and understand because symbolic names can be chosen to reflect the meaning of the numerical constant represented or the name of the field within a data structure which the symbol points to. Lastly, in the event that a numerical constant or displacement is ever changed, code using symbolic references is easier to update since the update necessitates changing only the symbol definition rather than every reference (as would be needed with numerical references).

Numerical constant symbols and displacement symbols (STRUCs) are used throughout the coding of OS/16 MT2 and these same symbols and STRUCs are equally usable by assembly language programmers writing programs to run under MT2. The collection of symbols and STRUCs related to OS/16 MT2 is contained in the Parameters and Control Blocks module supplied with the system source (filename PCB16.CAL for MT on disc). Some examples of uses by user tasks follow

1. Construction of a Task Status Word:

The status portion of a Task Status Word (TSW) enabling Trap wait, Task Queue service trap, Queue entry on Task call (queue parameter from another task) and I/O proceed termination can be written

```

COPY          UDL
              .
              .
              .
DC            TSW.WTM!TSW.TSKM!TSW.TCM!TSW.IOM
    
```

This expression instructs the assembler to OR together masks, each setting a particular bit, to form a word with all the required bits set. (Within the Parameters and Control Blocks module symbol definitions, symbols ending in 'M' have the value of the bit *mask* needed to enable a particular bit.)

2. Loading a TSW into the User Dedicated Locations (UDL)

A TSW enabling queue entry on I/O proceed termination and timeout completion is to be loaded into the "Task Queue service new TSW" field of the User Dedicated Locations, thereby allowing queue entries for these two events to continue while the Task Queue is being serviced. The TSW in question contains a LOC field pointing to the Task Queue service routine.

```

COPY          UDL
              .
              .
SVC           2,FETCH          GET ADDRESS OF UDL INTO R13
LM            R14,TSKQTSW      LOAD TSW INTO REGS 14-15
STM           R14,UDL.TSKN(R13) STORE INTO UDL
              .
              .
QSERVICE     EQU            *      TASK QUEUE SERVICE ROUTINE
              .
              .
FETCH        DB            0,2
              DC            13
TSKQTSW      DAC            TSW.IOM!TSW.TMCM,QSERVICE
    
```

Note that the one line definition of the TSW (TSKQTSW) generates two halfwords: a STATUS portion enabling certain bits and a LOC portion pointing to the task queue service routine as QSERVICE

3 Loading an SVC 6 function code into an SVC 6 parameter block

A function code specifying Load and Start immediately for some "other" task, (as opposed to a self-directed SVC 6) is loaded into an SVC 6 parameter block.

```

COPY      SVC6.
.
.
LHI       R14,SFC1.DOM!SFC1.LM      LOAD FUNCTION
LHI       R15,SFC2.SIM              START FUNCTION
STM       R14,PARBLK+SVC6 FUN      STORE INTO SVC 6 P.B.
.
.
PARBLK    EQU      *                  SVC 6 PARAMETER BLOCK
          DS       SVC6.

```

Note that the proper amount of space for the SVC 6 parameter block was reserved by a "DS SVC6." where "SVC6." is the label of the STRUC defining the SVC 6 parameter block and set by CAL to the size of the data structure so defined.

A field within a data structure can be referenced in one of two ways using a STRUC:

```

COPY      SVC6.
.
.
STM       R14,PARBLK+SVC6.FUN
.
.
DS       SVC6.

```

or referencing a field through an index register

```

COPY      SVC6.
.
.
LDAI     R3,PARBLK
.
.
STM       R14,SVC6.FUN(R3)
.
.
PARBLK    DS       SVC6.

```

The direct method has the advantage of not using an additional register while the index register method has the additional flexibility of passing the address of different parameter blocks through a register (perhaps to a subroutine).

The previous examples deal with applications where a program dynamically loaded various fields with appropriate values. This approach is correct for occasions where the contents of the various fields change with time and therefore, must be dynamically initialized and subsequently changed. However, for applications where the contents of fields remain the same for the duration of the task, it saves both assembly code size and execution time to assemble the appropriate values into the data structures. Some examples follow.

- 4 Assembling values into a UDL (assembling a UDL as part of a task requires an OPTION NOUDL statement in the TET/16 input at task establishment time):

TUDL	COPY	UDL	
	EQU	*	
	ORG	TUDL+UDL.TSKQ	
	DC	task queue addr	ADDRESS OF TASK QUEUE
	ORG	TUDL+UDL.PWRN	
	DC	status,loc	POWER RESTORE NEW TSW
	ORG	TUDL+UDL.TSKN	
	DC	status,loc	TASK QUEUE SERV NEW TSW
	ORG	TUDL+UDL	

Note that the label 'TUDL' is used so as not to conflict with 'UDL' which is defined in the UDL STRUC (invoked by the COPY UDL). To omit any of the above field definitions from the code simply delete the ORG to the relevant field plus the constant definition for that field. The 'ORG TUDL+UDL' sets the location counter past the end of the UDL.

- 5 Assembling Task ID and function code into an SVC 6 parameter block at PARBLK:

	COPY	SVC6.	
	.		
	.		
PARBLK	EQU	*	
	ORG	PARBLK+SVC6.ID	
	DC	C'TASKA	TARGET TASKID
	ORG	PARBLK+SVC6.FUN	
	DC	SFC1.DOM,SFC2.SIM	START IMMED.FUNCTION
	ORG	PARBLK+SVC6.	

NOTE

The ORG PARBLK+SVC6. sets the location counter past the end of the Parameter block.

STRUCs are provided for SVC 1, SVC 5, SVC 6, and SVC 7 parameter blocks, and the User Dedicated Locations. They can be used after a CAL 'COPY' of the relevant name (a COPY statement instructs CAL to include source from Logical Unit 7, in this case the Parameters and Control Blocks module):

<u>STRUC</u>	<u>COPY</u>
SVC 1	SVC1
SVC 5	SVC5.
SVC 6	SVC6.
SVC 7	SVC7.
UDL and TSW Bits	UDL

Refer to Appendix 3 for assembly listings of the complete Parameters and Control Block module.

NOTE

Certain fields and bits in the UDL, TSW and SVC 6 STRUCs are included for future extensions of the Operating System and should be ignored by users of R00 and R01 OS/16 MT2.

TASK PREPARATION

A task must go through various transitions between the time it is written by the programmer in assembly language (or a combination of FORTRAN and assembly language or FORTRAN alone) and the time it is run under OS/16 MT2. These steps include the following (refer to Figures 5-4, 5-5, and 5-6):

FORTRAN Compiler - if required, this compiles the FORTRAN source plus any imbedded assembly language into CAL source (see the *FORTRAN V Level 1 Reference Manual*, *FORTRAN V Level 1 Users Guide*, and *FORTRAN V Level 1 Run Time Library Manual* for details).

CAL Assembler - This translates the CAL assembly language into 16-Bit object format output (see the *Common Assembler Language Users Manual*).

TET/16 - This converts the object format output of CAL into memory-image format. References by the TASK to a resident library partition are resolved with TET RESOLVE command (Figures 5-4 and 5-6). Relevant routines from the library can be included in the task itself with a TET EDIT command (Figure 5-5). (See the *OS/16 MT Operators Manual*, Chapter 5, for a complete discussion of TET with additional examples.)

OS/16 MT2 - The OS/16 MT2 loader loads the task or library (via operator command or SVC 6) that was established by TET, and allows it to run on a 16-Bit Processor.

NOTE

For a task to use TASK COMMON, it must contain a labelled Common with the Label 'TSKCOM' at assembly time (the left-hand CAL box in Figure 5-4). All program references to this common block are resolved by TET/16 to a reference into user specified TASK common partition.

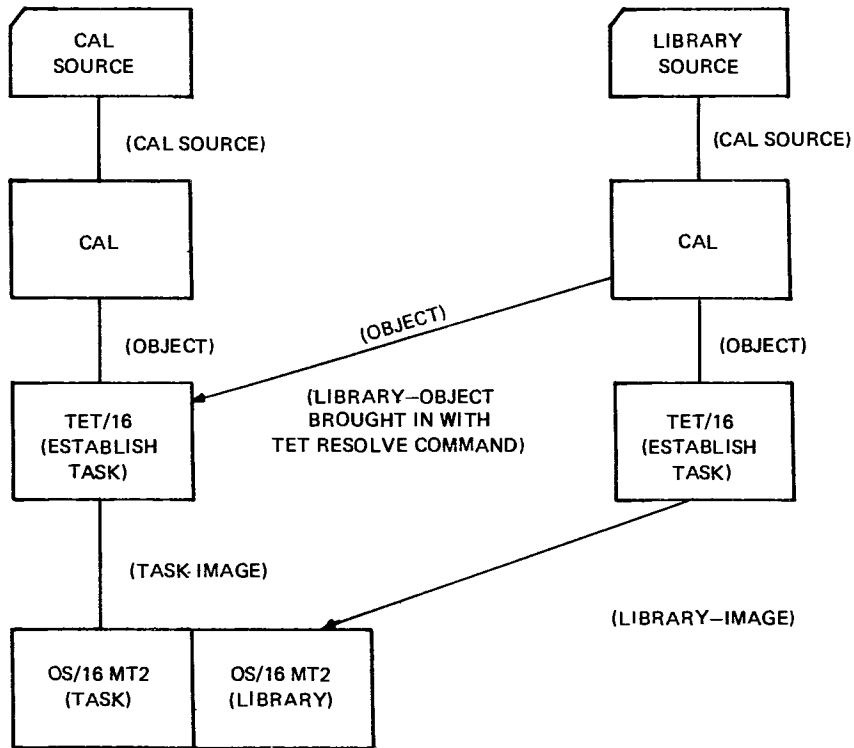

Figure 5-4. CAL Source

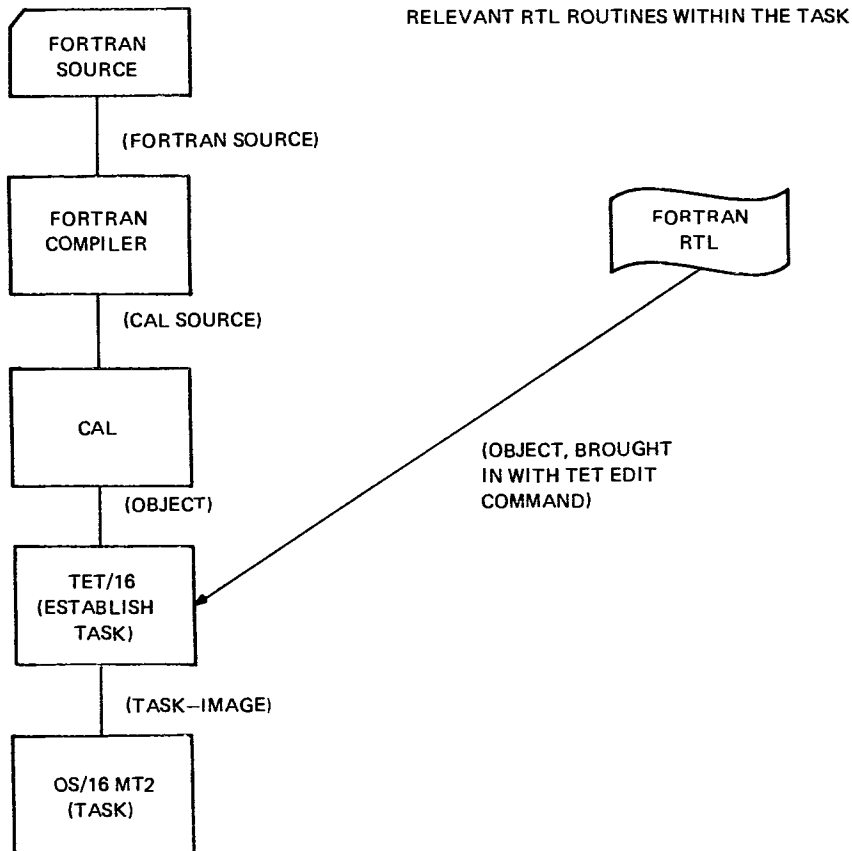

Figure 5-5. FORTRAN Source

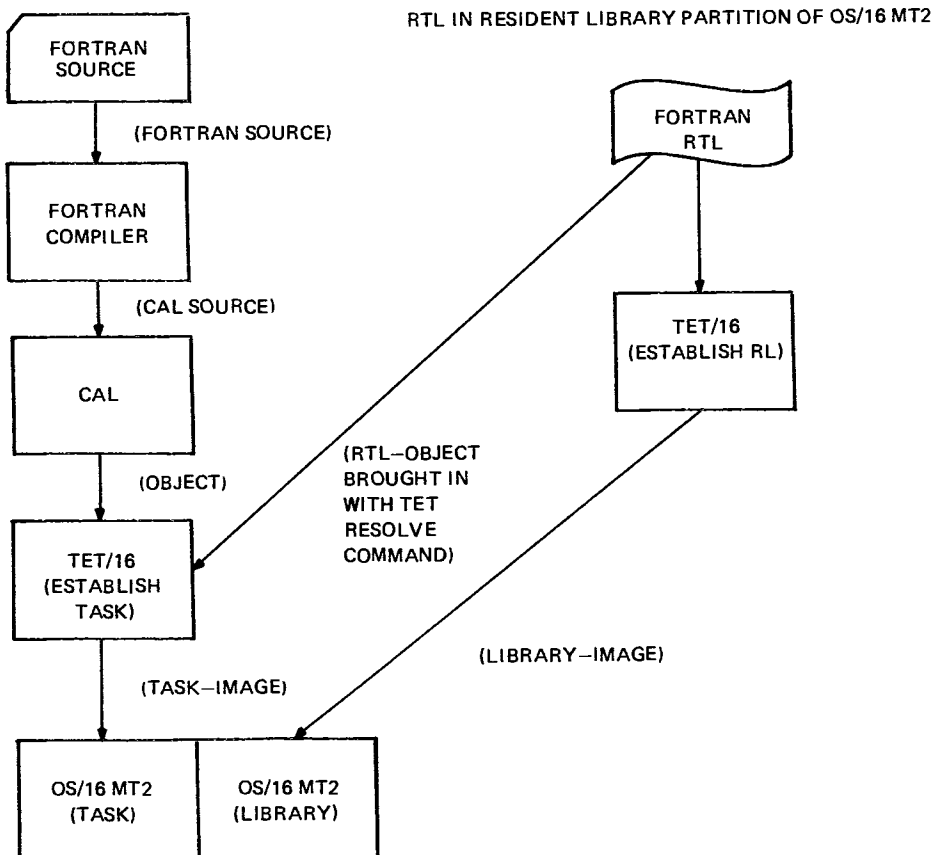

Figure 5-6. FORTRAN Source With RTL

CHAPTER 6

GUIDE TO OS/16 MT2 FILE STRUCTURES

DEFINITION OF TERMS

Certain terms, which are used in this section, must be defined in order to gain a good understanding of the concepts to be presented later. These definitions should be read by even the advanced reader, since the same terms have been used throughout the data-processing industry with unfortunate, inconsistent meanings. Refer to Chapter 6 of the System Planning and Configuration Guide for definitions.

FILE IDENTIFICATION

The OS/16 MT2 file is identified by a File Descriptor. The full name of a file has three parts: volume name, filename, and extension. The volume name is composed of one to four alphanumeric characters, of which the first character must be alphabetic. This is the name of the volume on which the file resides.

The filename consists of one to eight alphanumeric characters, of which the first must be alphabetic. This is the main identifier for the file, and may be anything the user chooses.

The extension consists of up to three alphanumeric characters. It may consist of no characters at all, in which case it is considered to be made of blanks. The extension usually denotes the type of material on the file. It may be anything the user chooses; however, some specific extensions are used by OS/16 and by some OS utilities, and are assumed to have specific meanings. These extensions are:

TSK	Task Image format
OBJ	Absolute or Relocatable loader format
FTN	FORTRAN source format
CAL	CAL assembly language source format
BAS	BASIC source format
ROL	Roll file for Roll In/Out
CSS	Command Substitution System source format
SPL	Spooled printer listing format
PRT	Spooled printer listing format
MAC	CAL Macro source format

Other extensions may be defined from time to time as required. The user may use any of these standard extensions, or may define others.

File Descriptors are written as follows:

VOLN:FILENAME.EXT

where VOLN is the volume name, FILENAME is the filename, and EXT is the extension. VOLN is often omitted in writing and in OS commands. EXT is sometimes omitted, in cases where the extension is already known.

Some examples of valid File Descriptors are:

FRED:PROGRAM.CAL	A program named PROGRAM, in CAL source format, on volume FRED.
FRED.PROGRAM.OBJ	The same program, in loader format.
FRED:PROGRAM.TSK	The same program in task image format.
GOLF BOGEY.XYZ	The volume now is GOLF; the extension XYZ is not standard, so no assumptions can be made about format.
FLAH BOGEY.XYZ	The same file on a different volume. Although all filename/extension combinations on any one volume must be unique, the same filename/extension may exist on more than one volume.

LULU. The volume name is omitted and should be identifiable in the proper context. The extension field is blank.

VOL3.DATABASE The extension is omitted here. This may not be the same as the blank extension, but the true extension should be identifiable from context.

Note that when the volume is specified, a colon (:) is always present. When the extension is specified, a period (.) is always present.

Some invalid File Descriptors are

2V.ABC.CAL	Volume name begins with a numeric
V3·FILE #2 OBJ	File name contains a non-alphanumeric
SYSVOL:FILE.DMP	Volume name too long
SV·EXT	File name nonexistent
PROGRAM325	File name too long

A file is originally named when it is allocated. At this time the specified name is checked to see if it is unique on the given volume. A file can be renamed at a later time, either by the console operator or by a user program. At this time, the new name is checked to make sure it, too, is unique

The renaming function can be used, for example, to handle the updating of a file, when it is desired to retain the older version of the file. One way to do this might be

(Assume the file to be updated is named FILE.XYZ)

1. Rename FILE.XYZ to be FILE.BAK
2. Allocate a new file named FILE.XYZ
3. Copy FILE.BAK onto file FILE.XYZ, adding update information as required.

Now there is a most-recent version named FILE.XYZ, and a next-most-recent version named FILE.BAK. When the backup is no longer needed, FILE.BAK may be deleted from the volume

FILE PROTECTION

Files may be protected in one of two ways: statically or dynamically.

Static Protection

Each file has two protection keys, one for Read access and one for Write access. These keys are first set up when the file is allocated. Each key is one byte long and may have any value.

If the values of the keys are within the range X'01' to X'FE', the file may not be assigned for Read or Write access unless the assigning task matches the appropriate keys. In other words, if a file's Read key is X'3A' and its Write key is X'57', a task trying to assign the file for Read access must supply a Read key of X'3A'. To assign this file for Write access, a Write key of X'57' must be supplied. In order to assign the file for both Read and Write access, the task must supply both keys.

The values X'00' and X'FF' have special meanings. If a key has a value of X'00', the file is unprotected for that access mode. Any key supplied by the assigning task is accepted as valid. If both keys have a value of X'00', therefore, any attempt to assign the file is accepted, regardless of the keys supplied by the assigning task.

If a key has a value of X'FF', the file is unconditionally protected for that access mode. It may not be assigned for that access mode by any task, regardless of the key supplied by the assignment task. However, an E-task (an executive task, with the same privileges as the operating system itself) may assign any file, even if its protection keys are set to X'FF'. Static protection does not apply to E-tasks

Some examples of Static protection are:

Write Key	Read Key		Meaning
00	00	Completely unprotected.
FF	FF	Unconditionally protected.
07	00	...	Unprotected for Read, conditionally protected for Write (user must supply Write key = X'07').
FF	A7	...	Unconditionally protected for Write, conditionally protected for Read.
00	FF	Unprotected for Write, unconditionally protected for Read.
27	32	Conditionally protected for both Read and Write.

Dynamic Protection

While a task is using a file, it may wish to prevent other tasks from accessing that file. An example might be a task that is updating a shared data base. In most cases, it would not be appropriate to let the data base be read while the updating operation is under way. For this reason, the task may ask for exclusive access privileges, either for Read or Write, when it assigns a file. If it is granted exclusive access, it may be sure that the file is not accessible by any other task until it is closed, or until the task voluntarily gives up exclusive access. This form of protection is called *dynamic* because it is only in effect while the file is actually assigned.

The access privileges are generally known by their abbreviations:

SRO	Shared Read-only
ERO	Exclusive Read-only
SWO	Shared Write-only
EWO	Exclusive Write-only
SRW	Shared Read-Write
SREW	Shared Read, Exclusive Write
ERSW	Exclusive Read, Shared Write
ERW	Exclusive Read-Write

Protection Modification

The protection keys of a file may be changed by the console operator, or by any task having that file assigned for Exclusive Read-Write (ERW).

A task may change its access privileges on a file without having to close the file. This is only possible if the proper conditions are met. A task having a file assigned for shared Read, for example, may not change to exclusive Read if the file is also assigned for shared Read to another task (or another Logical Unit of the same task). Access may always be changed from exclusive to shared, however.

If the user attempts to change access privileges, and for some reason is unable to get the new privileges, the old access privileges remain.

Multiple LU Considerations

The concept of exclusive access has been discussed in terms of multiple tasks sharing the same file. Here it was assumed that a single task does not attempt to assign the same file to multiple Logical Units (LU). Occasionally, however, a case arises when the task does desire to assign the same file to multiple LUs. This might occur as a result of default assignments or assignments made by the console operator. In this case, exclusivity applies between LUs just as between tasks. This means that a file cannot be assigned for exclusive Read access on one LU and shared Read on another. If a file is assigned for exclusive Read or Write access on any given LU, it may not be assigned for that kind of access on any other LU.

Assume that a file is open on LU 1 and LU 2 at the same time. The following matrix shows the compatible combinations:

		LU 2							
		SREW	EWO	SWO	SRW	SRO	ERO	ERSW	ERW
LU 1	SREW	-	-	-	-	*	-	-	-
	EWO	-	-	-	-	*	*	-	-
	SWO	-	-	*	*	*	*	*	-
	SRW	-	-	*	*	*	-	-	-
	SRO	*	*	*	*	*	-	-	-
	ERO	-	*	*	-	-	-	-	-
	ERSW	-	-	*	-	-	-	-	-
	ERW	-	-	-	-	-	-	-	-

* = compatible
 - = incompatible

ACCESS METHODS

OS/16 supports two methods of access to files. random and sequential. These methods may be intermixed without having to close and reassign the file. The chief mechanism used to implement these methods is the current record pointer.

The current record pointer is a number, ranging from zero to the number of records currently in the file, indicating the record to be read or written on the next sequential access to the file. Each record is numbered in sequence, starting with ZERO.

The current record pointer may be adjusted in one of several ways

1. It is set to ZERO by the following operations:
 - Rewind
 - Backspace to filemark (except on contiguous files)
 - Assigning (except for Write-Only access)
2. It is set to the number of records in the file (the proper position to append new records) by the following operations:
 - Assigning for Write-Only access
 - Forward to filemark (except on Contiguous files)
3. It is decremented by one by a backspace record operation, unless the file is already positioned at its beginning
4. It is incremented by one as follows:
 - Forward record (unless already at end of file)
 - Sequential Read or Write
5. A random Read or Write sets the current record pointer to a value one greater than the record read or written.

Use of the Unbuffered Physical buffer management method causes the current record pointer to be reinterpreted to a certain extent. This is discussed fully, later.

Random Access

For random access, the user supplies the record number to Read or Write. This record is found, data transfer is performed, and the current record pointer is set to point to the next sequential record. If the user continues to use random access, there is no need to pay attention to the current record pointer, since it is readjusted on every call. However, the user may wish to read or write a sequence of records, starting with a known record number. In this case, one would use a single random call and follow with a number of sequential calls.

On Indexed files the user is somewhat restricted in the use of the random Write call. This call may be used to update any record currently in the file, or to append one record to the end of the file. If the record number specified is more than one record past the end of the file, the call is rejected with EOF (end of file) status. Effectively, this means that a file must be expanded sequentially. If the file has only five records, a sixth may be added but record number 100, for example, cannot. Otherwise, the system would have to create a large number of null, or vacant, records between the old end of the file and the new record. For reasons of safety and time considerations, OS/16 does not do this.

On Contiguous files there is no restriction on the use of the random Write or Read call. Any record within the file's allocation may be read or written.

Sequential Access

Sequential access is the simplest and most common access method. The user performs a series of sequential Read or Write calls. These cause records of the file to be read or written in sequence. The current record pointer is adjusted automatically at each access. The REWIND, FORWARD RECORD, BACKWARD RECORD, FORWARD FILE, and BACKWARD FILE commands may be used for repositioning as described previously.

BUFFER MANAGEMENT

OS/16 MT2 supports two buffer management methods. Buffered Logical (BL) and Unbuffered Physical (UP). One of these buffer management methods is specified each time a file is assigned. From that time until the file is next closed, the buffer management method may not be changed. The buffer management method is logically independent of file structure, access method, or the contents of the file.

Buffered Logical

In the Buffered Logical (BL) method, files are divided into *logical records*. These logical records may be of any length, regardless of the physical block size of the file. The logical record length for any given file is fixed at the time it is allocated. Thereafter, it is a permanent attribute of that file. It would be impossible therefore to write twenty-byte records on a file one day, and then the next day to write eighty-byte records on the same file without resorting to subterfuges.

It is possible to read or write less than a logical record; however, this can waste space, since the file is divided physically into logical records of the size specified at the time the file was allocated. Likewise, it is not possible to write variable-length records on a file without wasting space. In such a case, the logical record length specified at allocation time must be the size of the longest record ever to be written on that file. If the user tries to read or write a record that is longer than the file's logical record length, data is lost on a write operation, and is not returned on a read operation.

The BL buffer management method packs logical records into physical blocks as efficiently as possible, allowing logical records to overlap into the next physical block if necessary. For example, if the amount of space in a physical block that is available for data storage is 256 bytes (a common figure on an Indexed file), and the logical record length is 80 bytes, sixteen logical records are packed into five physical blocks. The logical record size may exceed the size of a physical block. The only restriction on logical record size is that no logical record may exceed 65,535 bytes.

All logical to physical transformations are handled automatically by the BL buffer management method. When a block is read or written, the actual data transfer takes place between the device and a buffer in system space. This buffer is not accessible to the user program. When a task reads or writes a record, data is transferred between the task and the system buffer. Actual reads and writes take place only when required. All actions of the buffer management method are fully transparent to the user.

The BL buffer management method is probably the most convenient for general-purpose use. For sequential access, it is highly efficient, and it makes good use of disc space. Its primary drawback lies in the area of random writes. In order to update a record, the physical block that the record lies in must be read first, to keep from destroying data in records that are in the same block but not being updated. Therefore, a random updating process may require a number of disc accesses that is far out of proportion to the number of records being updated.

Unbuffered Physical

The Unbuffered Physical (UP) management method does not operate on logical records, but works directly on physical blocks. Data is transferred directly from a buffer in the user program to the device, without being moved into a system buffer. For a Write operation, data is moved directly from the device to the user program.

The current record pointer is reinterpreted in the UP method. In this buffer management method, the current record pointer points to the current physical block. Otherwise, it is the same as in the BL method. All data transfers must begin on a physical block boundary. The length of data to be transferred may be less than the size of a physical block. The Contiguous file structure permits data transfers larger than a physical block, of any size up to the total size of the file. In this file structure, therefore, the current record pointer may be incremented by more than one following a data transfer.

The advantages of the UP method lie in the speed with which data transfers can be done. There is no time required for moving data in core between system and user space if this method is used. Its primary disadvantage is that space on the volume is often wasted when using this method.

FILE STRUCTURES

OS/16 MT2 supports two file structures. Although these structures differ, in most cases the same data manipulations can be performed on one structure as another. The user's choice of file structure does not usually depend on the kind of data to be put in the file, but on the way the data is to be accessed. OS/16 file structures are each optimized for one specified form of access.

OS/16 file structures may be broadly divided into two categories: open-ended and closed. An open-ended structure may expand dynamically as new data is added. The maximum size of an open-ended file is limited only by the amount of space available on its volume. When an open-ended file is allocated, no space is reserved for it on the volume; space is only seized as it is required. The Indexed file structure is open-ended.

A closed structure is limited in size at the time it is allocated. Space is reserved for it at that time. Thereafter, it may neither expand nor contract. The Contiguous file structure is closed.

The advantages of open-ended structures are many. First, the user need not worry about the maximum size of the file. (This parameter is often difficult or impossible to compute.) Second, unused space on the volume is not wasted, but is available for use by other files. This tends to permit a greater number of files per volume. In most cases, the user programmer should choose an open-ended file structure.

The primary advantage of closed structures lies in the fact that all the space required for the file is reserved at allocation time. If the maximum length of the file is known, the user may be sure that there is always room for the data and that no other tasks have preempted needed disc space. This advantage comes at the cost of wasted space on the volume.

At this time, not all access methods and buffer management methods are supported on all file structures.

Indexed Files

The only open-ended file structure in OS/16 MT2 Release 00 is the Indexed file. The Indexed structure consists of a chain of index blocks (see Figure 6-1). The first two fullwords of each index block are used as links. The first fullword points to the previous block (it is zero in the first block). The second fullword points to the next block (it is zero in the last block). The rest of the index block contains fullword pointers to the data blocks which are the physical records of the file. Two fullword pointers in the volume directory point to the first and last index blocks.

At allocation time, two physical block sizes may be specified. They are the index block size and the data block size. Normally, these block sizes are one sector each (256 bytes), but any number of sectors may be specified. The index block size determines the number of data pointers to be contained in one index block. The data block size determines the amount of data space available in one data block. 256 bytes of data are contained in a one sector data block.

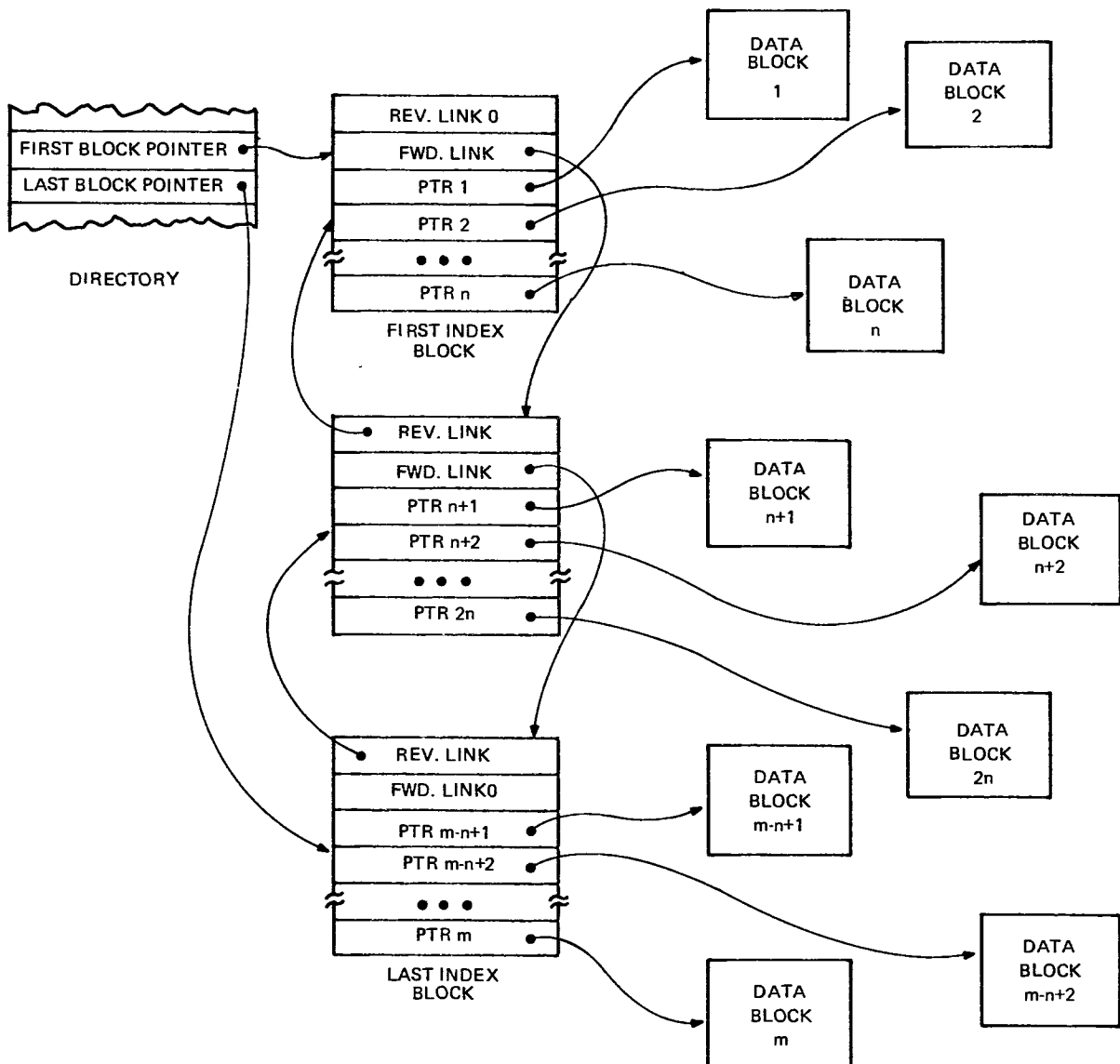

Figure 6-1. Indexed File Structure

Contiguous Files

The Contiguous file structure (see Figure 6-2) is a closed-ended file structure supported by OS/16. As the name implies, all blocks of a Contiguous file are allocated contiguously on the volume. The file size is specified at the time of allocation, and all required space is reserved at that time. This gives the Contiguous file certain characteristics that are unique to this file structure.

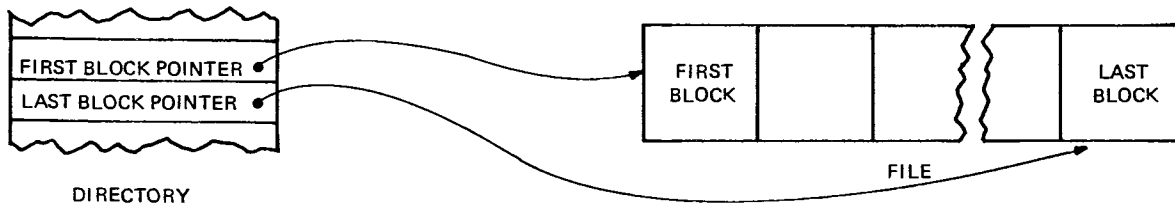

Figure 6-2. Contiguous File Structure

Random Reads and Writes may access any record or block on the file, regardless of which records have been previously written. This makes it possible to create a Contiguous file in a truly random fashion (At the same time, it should be noted that it is possible to read a record or block that has never been written. In such cases, the data returned is not defined.)

The Contiguous file supports a pseudo-filemark capability that gives it some of the characteristics of a magnetic tape device. The filemark is X'1313' at the beginning of a record or block. Care should be taken to ensure that this datum is not inadvertently written at the beginning of a record or block. The forward-file and backward-file operations on a Contiguous file work as they would on a magnetic tape. That is, the file is positioned forward or backward respectively until a "filemark" is found. The current record pointer is then left following or preceding this filemark, respectively. Note that this removes the capability of setting the file up for an append operation by using the forward-file command. (It may still be set up for append by initially opening it for Write-Only). The Write-filemark operation is implemented on this file type, and results in the writing of the X'1313' mentioned previously.

It is permissible to read or to write data longer than the physical block length of a Contiguous file. The physical block length of a Contiguous file is always one sector, or 256 bytes. The current record pointer is adjusted to point to the next block following the data transfer, in this case.

Use of the Contiguous file provides the fastest possible means of access to Direct-Access storage. If time is of the essence, this structure should be used. However, it wastes space, is not open-ended, and requires a number of contiguous vacant sectors on the volume in order to allocate such a file. A Contiguous file, therefore, may be impossible to allocate on a heavily-used checker-boarded disc.

FILE MANAGEMENT

This section discusses the use of the Allocate, Assign, Close, Delete and Checkpoint calls. The Rename and Reprotect calls have been discussed as has the Change Access Privileges call.

Allocation

When a file is allocated, its directory entry is built and, if it is a Contiguous file, space is reserved for it on the disc. The allocation of a file does not cause the file to be assigned; this is done by the Assign call. A file may be allocated either from the system console or from a user program. Regardless of how a file is allocated, however, certain information must be specified:

Volume ID:	This specifies the volume on which the file is to be allocated. It must be the name of an on-line Direct-Access volume; otherwise, "volume error" is returned.
Filename/extension:	This gives the newly allocated file its name. There must not be any other file of that name and extension on the specified volume; otherwise, "name error" is returned.
Write key/Read key.	This sets up the initial protection keys for the file.
Logical record length:	This sets the logical record length for the file. It may be any size up to 65,535 bytes; however, it may not be changed. If the logical record length is set to ZERO, the BL management method may never be used with this file.
Size	For a Contiguous file, this is the size of the entire file, in sectors. May be any size up to the maximum amount of contiguous space available on that volume at that time. If too large, "size error" is returned. For an Indexed file, this field is broken up into two halfwords. The first halfword is the index block size, the second halfword is the data block size. These block sizes are specified as a number of sectors (never greater than 255). If the index block size is specified as ZERO, an index block size of ONE is used.
File type	Indexed or Contiguous

Assignment

To assign a file to a Logical Unit, the Assign call (SVC 7) is used from a user program, or the ASSIGN command from the system console. At this point, the desired access privileges and buffer management method must be specified. The Read key must be given, if Read access is requested; the Write key must be specified for Write access.

At the time of assignment, the system allocates, out of system space, a File Control Block (FCB) and buffers for the file. The buffer space required, if any, depends on the chosen buffer management method and on the file's physical block size. If the physical block size of the file is too great for the amount of remaining system space, the file may not be assigned. In this case, a buffer error status is returned; the user program may attempt to relinquish some memory and then retry the assignment. If that does not work, the user has little choice but to complain to the console operator and abort the task. Of course, if the user has another file assigned that can be closed, that can be done to release space to the system.

For this reason, the user should not keep files assigned longer than necessary. In addition, the physical block length of files should be kept as short as possible unless there are overriding considerations.

Closing

A file may be closed at any time by issuing a Close call. No information other than Logical Unit need be specified. The system waits for any incomplete data transfers to terminate, flushes the buffers (that is, writes out to the volume any partly filled buffers), and updates the file's directory entry. The Logical Unit that the file was assigned to is deassigned.

Deletion

A file may be deleted only if it is not currently assigned to any task. The user must supply the volume name, file name and extension, and both Read and Write keys. When a file is deleted, all its space on the volume is released and may be used by the files.

Checkpointing

The Checkpoint call performs the buffer-flushing and directory-updating functions of a Close call, without performing any of the other functions of a Close operation. This is essentially a protective operation that can be used to guard against system failure, either for very critical files, or for files assigned for lengthy periods of time without being closed.

Since the directory is only updated at close or checkpoint time, data appended to a file after the latest close or checkpoint operation is lost at system failure for certain types of files and buffer management methods. When a file is closed or checkpointed, however, all data appended prior to that time is guaranteed safe through a system failure, providing that the system failure did not destroy the volume directory.

The checkpoint operation is never required for Contiguous files, since data is written directly to the disc, and this file structure does not use dynamic disc allocation techniques.

The checkpoint operation is not required for Indexed files if no new records are created (that is, if only already-existing blocks are being updated). If new records are being created (i.e., append operations), the checkpoint operation may be desirable.

TRADEOFFS

In the areas of file structure, buffer management method, and access method, there are many choices which may be confusing to the programmer. The following data is presented to assist the programmer in making this choice.

If pseudo-filemarks are required for magnetic tape emulation, the Contiguous file structure is required. This may be the case when magnetic tape-oriented programs are to be used.

If the maximum length of the file is completely unknown, the Contiguous file is ruled out. Only an open-ended file structure will do in this case. Most applications, however, generally define files in such a way that it is possible to make a good guess at the maximum length of each data structure. In this case, assuming the disc is not badly checkerboarded, the Contiguous file may be considered. (If the disc is checkerboarded, the allocation of a large Contiguous file may not be possible.)

Between the Indexed and Contiguous file structures, if the file is to be read and written using sequential access, the Indexed file structure is the obvious choice. If the file is long and is to be accessed randomly, the Contiguous file structure is usually preferable. However, this choice is not always clear, for the following reasons:

Random access may be more or less efficient depending on the average access distance. If the distribution is equiprobable, that is, if the likelihood that any one record will be selected for the next data transfer is the same as for any other record, the mean search distance is 1/3 of the length of the file. If the distribution is highly localized, the Contiguous file structure has few advantages over the Indexed.

If the REWIND and FORWARD-FILE commands (which do not cause disc accesses) are used, the mean search distance may be reduced from 1/3 of the file length to 1/6 of the file length. This also tends to make the Indexed file look a little better.

Once the choice of the Indexed structure has been made, the physical block size must be selected. Cogent reasons have been given for keeping the physical block size small. However, a large block size can be very helpful in some cases. The main time factors involved in a disc access are seek time (for moving-head discs) and rotational latency time. These times, on the average, far overshadow the actual data transfer time. Therefore, a transfer of two or more sectors generally costs little more time than a transfer of only one sector. For this reason, the number of disc accesses is the critical figure in computing the time required to access a file. A large physical block size can reduce by far the number of accesses. Here it is important to consider performance of the overall system. If a given task is not critical, and is running in a multitasking environment, other tasks can be active while it waits for disc accesses. If the task is critical, however, or is running in a single-tasking environment, a large physical block size may reduce its running time.

Finally, if speed of access is paramount and the file size is fixed, the Contiguous file structure should certainly be used. There is no time overhead associated with finding data using this file structure. The amount of system overhead used in accessing Contiguous files is less than for any other file type.

The compatibilities between these file types far outweigh their incompatibilities. It is quite possible to write programs that can use any or all of these file structures indiscriminately. If programs are written in such a manner, then the user can actually try out the application using the various possible file structures in order to find out which is more efficient. In addition, the programs are able to use files which may be the output of other dissimilar programs or which may previously have existed.

The Contiguous file is compatible with the Indexed file, providing that the Contiguous files extraordinary treatment of filemarks can be ignored.

CONCLUSIONS

The OS/16 file structures and access mechanisms are basic building blocks. They are not oriented towards any specific application, or toward any specific class of applications. These structures, methods and mechanisms are designed to give the user programmer a set of tools. By using these tools one should be able to build a set of data structures specifically suited to whatever the application may be.

CHAPTER 7

GUIDE TO USER OVERLAYS

INTRODUCTION

In order to minimize the amount of memory necessary to run a task, OS/16 MT2 allows the user to design a task in segments and control those segments such that only those that are necessary must be in memory at any one time. Such a task consists of the root segment, which is in memory for the duration of the task, and a number of overlay segments, which are brought into memory when necessary, at the task's request. This chapter discusses the use of overlays to reduce the memory required to execute a task.

A task to be overlaid usually is designed as a main program with a number of subroutines. Before being executed under OS/16 MT2, this main program and its subroutines must be established as a task by the OS/16 Task Establisher Task (TET/16). TET/16 processes 16-Bit loader format programs and produces memory image load modules. TET/16 resolves EXTRN and ENTRY references by linking or editing in the specified programs. References to Task Common and Resident Library routines are also processed by TET (see Chapter 1 of this manual and Chapter 4 of the OS/16 MT2 Operators Manual). If no overlay facility is to be used, TET/16 processes the specified main program and subroutines and produces one image load module containing all the task's routines and data areas in the order processed. If overlays are to be used, TET/16 is used to produce an image load module containing the root segment and multiple areas of reserved space, and one or more image load modules that contain overlay segments to be loaded into the space reserved in the main program.

ROOT AND OVERLAY SEGMENTS

For an overlaid task, the root segment consists of all the programs, subroutines and data areas that must be in memory throughout the execution of the task. At TET time, the user must specify:

- The programs to be linked or edited into the root.

- All Block Data programs used by the task.

- The maximum amount of memory obtained through Get/Release Storage requests or any non-standard internal memory requirements.

- The starting address of the partition the task is being established for.

To produce overlay segments, the user specifies the programs and Block Data programs to be linked into each overlay and a unique name to be associated with the overlay load module. After all the overlays to be loaded into the first overlay area have been processed, the user can then specify the overlays to be loaded into a second overlay area. Up to 127 overlay areas can be defined in this manner. Overlays to be loaded into the same overlay area are said to be on the same level.

Figure 7-1 illustrates the organization of a sample memory map for a task using two overlay areas: the image load module containing the root segment and any common blocks necessary. This segment reserves space for Get Storage requests and for each overlay area. The user must specify the starting address of the partition the task is being established for. After processing the routines and data areas to be included in the root, TET reserves the user-specified number of bytes for Get Storage requests. If no value is specified, TET uses a value based on the requirements of the FORTRAN Run Time Library (RTL). In specifying the Get Storage area, the user must consider Get Storage requests issued by the root and all overlays, since all such requests are obtained from this area and any additional non-standard memory requirements of the task. From the size of the root segment, TET fixes the start of the first overlay area. The starting address of subsequent overlay areas is set to the starting address of the previous overlay area plus the size of the largest overlay produced for that previous area. The Get Storage area is reserved above the last overlay area.

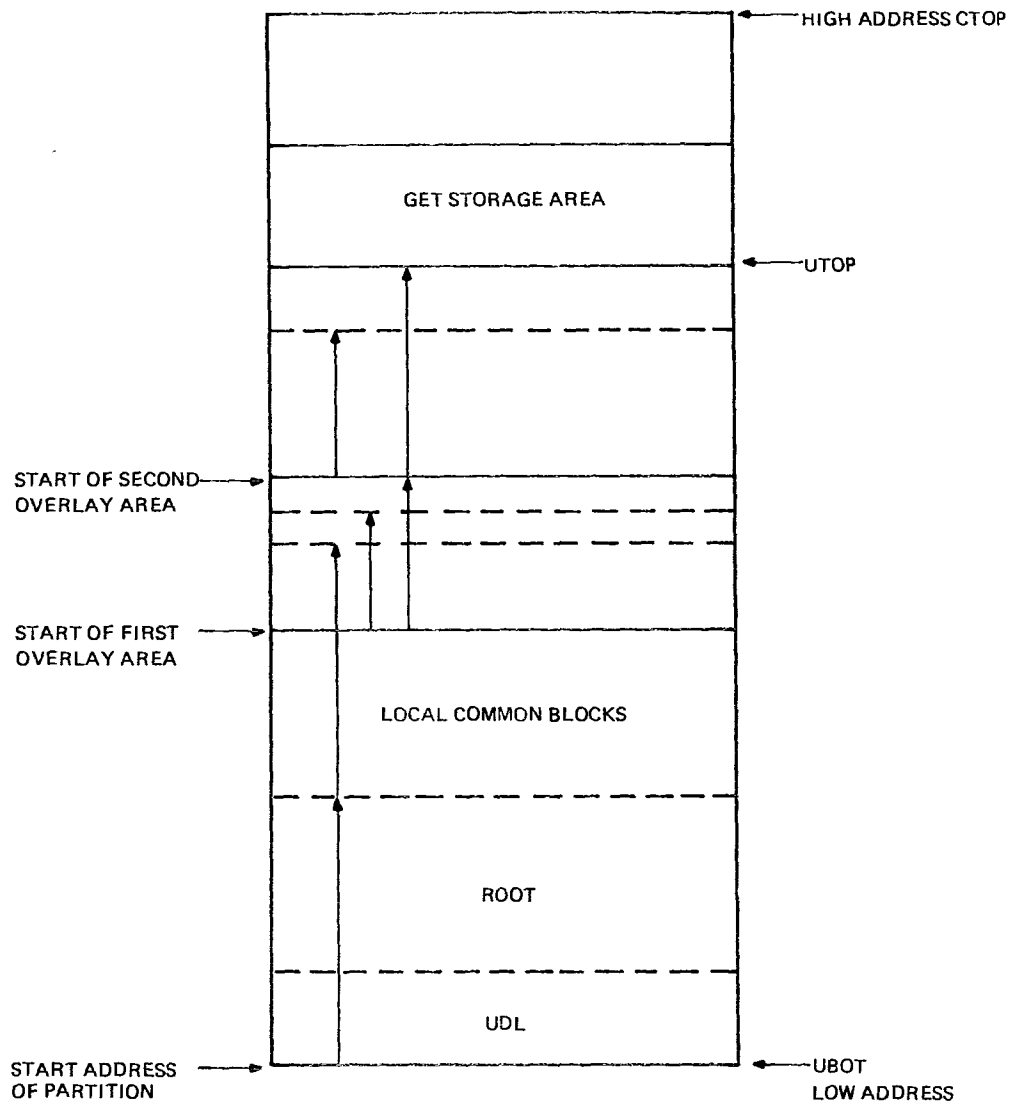

Figure 7-1. Partition For An Overlaid Task

OVERLAY CONVENTIONS

This section discusses the conventions that must be followed in the design of an overlaid task in order to ensure proper coordination between the various segments. At execution time, an overlay segment is loaded into memory via an SVC 5, Fetch Overlay request. The SVC 5 parameter block specifies the Logical Unit assigned to the file or device containing the desired overlay, and the name associated with the overlay at TET time. An overlay load request may be issued by the root segment or by an overlay segment with the exception that an overlay must not be loaded in the overlay area occupied by the segment requesting the load. SVC 5 returns an error: if the overlay could not be loaded because of an I/O error, a name mismatch or the overlay does not fit into memory available (see Chapter 3 for SVC 5 details). The root can reference any overlay that is loaded and an overlay can reference the root or any overlay loaded into another overlay area. It is not necessary to load an overlay if it is known to be in memory.

In order to ensure proper resolution of EXTRN and ENTRY references no overlay may define an ENTRY already defined in the root or in an overlay in a different overlay area. Overlays designed for the same area may separately include the same subroutine name provided that there are no references to that name by segments not in that area. For example, suppose a task consisted of a root segment and three overlays sharing the same area. If two of the overlay segments require a common routine, such as the SINE subroutine, it is possible to link the SINE routine into each of the two overlays. An error would result at TET time if the SINE routine was also linked into, or referenced by, the root.

OVERLAY DESIGN CONSIDERATIONS

Task Level

There are many considerations which determine the optimum number of overlay areas and what routines are loaded into the various areas. This section suggests a few of these considerations.

If one large overlay is to share an area with a number of small overlays, determine if the large overlay could share another area with a similar size overlay, thus reducing the size of the first area. In other words, in the absence of coordination restrictions, a design which places only overlays of similar sizes in the same overlay area minimizes memory requirements. If all routines, referencing a particular common block, form one overlay, then the common block should be part of that overlay instead of requiring space in the root segment. If two overlays in the same overlay area communicate via a labeled Common block, then that block must be defined and positioned in the root segment or an overlay in another overlay area which is in memory during the time the Common block is referenced.

It may also be possible to use the Get Storage area for temporary storage used by Overlay Segments. If overlays are to use this area, it is important to coordinate Get/Release Storage (SVC 2) requests from the overlays with such requests from the root segment or from resident library routines. If overlays get the required storage on entry and release the same amount on exit, and all overlay segments are invoked as subroutines, the Get/Release requests would be processed in the correct order. In calculating the amount of Get Storage area to reserve, the user must consider the maximum number of bytes that may be gotten at any one time by the root segment, overlay segments and reentrant library routines.

System Level

In designing a series of tasks to be run as a system under OS/16 MT2, it is necessary to choose the most efficient partition configuration to contain the tasks. The same coordination considerations used in designing an overlay structure enter into designing the partitioning structure. The user must decide what tasks must be in memory simultaneously and what tasks may share a partition. After deciding which tasks may share a partition, these tasks should be established. The maps produced by TET can then be used to choose the starting address for the next partition. After all the partitions have been determined, the SET PARTITION operator command can be used to partition the user space.

OVERLAY EXAMPLE

Figure 7-1 illustrates the mapping of a partition containing a task with two overlay areas. The root segment consists of the User Dedicated Locations, the main program and subroutines, a number of local Common blocks defined in those subroutines and 512 bytes of Get Storage area. The first overlay area is designed to hold one of three overlays named ABC, DEF, or GHI. The second overlay area is designed to hold one of two overlays named JKL and MNO. Each overlay is to be output to a file named XXX.OVY where XXX is the overlay name. Overlay GHI consists of a main routine and several subroutines, the remaining overlays consist of a single subroutine. Figure 7-2 illustrates the TET/16 commands used to establish the task.

ESTABLISH	TA	
INCLUDE	TASK.OBJ	LOAD MAIN PROGRAM
EDIT	SUBRTN.OBJ	LINK SUBROUTINES
GET	200	RESERVE 512 BYTES
OVERLAY	ABC,NEW	DEFINE NEW OVERLAY AREA FOR ABC
INCLUDE	ABC.OBJ	LOAD OVERLAY PROGRAM
OVERLAY	DEF	USE SAME AREA FOR DEF
INCLUDE	DEF.OBJ	LOAD OVERLAY PROGRAM
OVERLAY	GHI	USE SAME AREA FOR GHI
INCLUDE	GHI.OBJ	
EDIT	GHISBR.OBJ	LINK GHI SUBROUTINES
OVERLAY	JKL,NEW	DEFINE NEW AREA FOR JKL
INCLUDE	JKL.OBJ	LOAD OVERLAY PROGRAM
OVERLAY	MNO	USE SECOND AREA FOR MNO
INCLUDE	MNO.OBJ	
BUILD	TASK,TASK TSK	OUTPUT ROOT SEGMENT
BUILD	OV,ABC.TSK	AND OVERLAYS
BUILD	OV,DEF.TSK	
BUILD	OV,GHI.TSK	
BUILD	OV,JKL.TSK	
BUILD	OV,MNO.TSK	
MAP		OUTPUT MAP OF ROOT AND OVERLAYS
END		

Figure 7-2. Establish A Sample Overlaid Task

CHAPTER 8

INPUT/OUTPUT PROGRAMMING

INTRODUCTION

All input/output requests are made via Supervisor Call SVC 1. SVC 1 is described in general in Chapter 3. This chapter discusses the functional aspects of the devices and Direct-Access files supported by OS/16 MT2. Included is specific device dependent information such as supported functions, status returned, and formatting performed.

All devices and files support ASCII formatting, Proceed I/O, sequential access and non-unconditional proceed, unless otherwise noted in the individual driver or file handler description. The supported attributes listed with each description are in addition to those listed previously.

CONTIGUOUS FILES

Supported Devices

Contiguous files are supported on all devices supported by the Moving Head Disc Driver or the Floppy Disc Driver. Device Code is 0(0)

Supported Attributes

Read, Write, Binary, Wait, Random, Unconditional Proceed, Image, Rewind, Backspace Record, Forward Space Record, Write File Mark, Forward Space File Mark, Backspace File Mark. Fixed length 256 byte records.

Functional Description

Contiguous files may be accessed either randomly or sequentially. These two access methods may be mixed without closing and reassigning the file. Records are accessed by referring to the current record pointer. The current record pointer is a number, ranging from zero to one less than the number of sectors allocated to the file. For sequential access, the value of the current record pointer, as left by the previous operation, is used to access the file. For random access, the user specifies the current record pointer to be used. When a contiguous file is assigned, the current record pointer is set to zero.

Read: (ASCII, Binary, and Image modes are identical.) The requested data is read from the disc, starting at the sector specified by the value of the current record pointer (sequential access) or by the random value specified in the SVC 1 call (random access), directly into the user specified buffer. The current sector pointer is set to 1 past the last sector involved in the transfer. All Reads begin on a sector boundary and end when the specified number of bytes have been transferred.

Write Same as Read, except the data is transferred from the user specified buffer to the disc. If the number of bytes transferred is not an integral multiple of 256, the last byte in the buffer is propagated to fill the last sector involved in the transfer.

Test and Set: Test and Set operation, specified by setting both Read and Write bits in the SVC 1 function code (X'60'), is implemented to provide compatibility with previous INTERDATA operating systems. Test and Set allows a task to access a file, or sector within a file, and at the same time mark it as being in use. Test and Set causes the requested data to be read into the specified buffer. Before control is returned to the task, the first halfword of the data is checked for a halfword of zero (X'0000'). If this halfword is zero, it is changed to X'FFFF', the record is rewritten to the file, and control is returned to the task with a Condition Code of zero. If the halfword is already X'FFFF', control is returned to the task with a Condition Code of X'F'. If the halfword is neither zero nor X'FFFF', control is returned with zero Condition Code. I/O proceed request for Test and Set (bit 4 of SVC 1 function code reset) is treated as a Wait request, except that an I/O Proceed complete queue entry is made, if enabled.

Rewind.	The current record pointer is set to zero.
Backspace Record	The current record pointer is decremented by one. If it is already zero, it is left at zero.
Forward Space Record.	The current record pointer is incremented by one. If it is equal to one less than the number of sectors in the file minus one, it is unchanged.
Write File Mark:	A record containing X'1313' as the first halfword is written to the current record. The current record pointer is incremented by one.
Forward Space Filemark	The file is read from the current record until a record containing an X'1313' as the first halfword is found. The current record pointer is updated to point to the record following the file mark record. If no filemark record is found, the current record pointer is set to one less than the number of sectors in the file and End of Medium (EOM) status is returned.
Backspace File Mark.	The file is read backwards, starting with the record before the current record, until a record containing an X'1313' as the first halfword is found. The current record pointer is updated to point to the record containing the filemark. If no filemark record is found, the current record pointer is set to zero and End of Medium (EOM) status is returned.

Status Definition

Status	Meaning
X'00'	Normal Completion.
X'A0'	Device Unavailable.
X'90'	End of Medium (EOM). Request results in current record pointer equal to or greater than the number of sectors in file.
X'88'	End of File (EOF) Record containing X'1313' as first halfword detected during Read, Write, Forward Record or Backspace Record request.
X'84'	Unrecoverable error on device.
X'82'	Data Transfer error after 5 retries

NOTE

Contiguous files are truly random files. Records may be accessed in any order. The records are fixed length (256 bytes) and all sectors in the file are reserved in a contiguous block at allocate time. Contiguous files support a pseudo filemark capability that gives them some of the characteristics of a magnetic tape device. Since the pseudo filemark is a halfword of X'1313' at the beginning of a sector, care should be taken to ensure that this datum is not inadvertently written at the beginning of a record.

INDEXED FILES

Supported Devices

Indexed files are supported on all devices supported by the Moving Head Disc Driver or the Floppy Disc Driver. Device code is 2(2)

Supported Attributes

Read, Write, Binary, Wait, Random, Unconditional Proceed, Image, Rewind, Backspace Record, Forward Space Record, Write File Mark, Forward Space File Mark, Backspace File Mark. Fixed length 256 byte records.

Functional Description

Indexed files may be accessed either randomly or sequentially. These two access methods may be mixed without closing and reassigning the file. Records are accessed by referring to the current record pointer. The current record pointer is a number ranging from zero to one less than the number of records in the file. For sequential access, the value of the current record pointer, as left by the previous operation, is used to access the file. For random access, the user specifies the current record pointer to be used. When an Indexed file is assigned for Exclusive Write Only (EWO) or Shared Write Only (SWO), the current record pointer is set to the number of records in the file (the correct value for appending records); for all other access privileges, the current pointer is set to zero.

Read:	(ASCII, Binary or Image modes are identical) The block containing the start of the logical record specified by the value of the current record pointer (sequential access) or by the random value specified in the SVC 1 parameter block (random access) is read into a system buffer (unless it is already in memory). The requested number of bytes are moved from the system buffer to the user specified buffer. The transfer ends on user buffer full or when a number of bytes equal to the logical record length of the file has been moved. The current record pointer is set to the record following the record accessed. Any physical reads necessary to complete the transfer are completed by the system.
Write	Same as Read, except the data is moved from the user buffer to the system buffer. The system buffer is flushed, whenever necessary, by the system. If a current record pointer value of one greater than the last record in the file is specified, a record is appended to the file, thus allowing the Indexed file to be extended at any time. If the size of the specified buffer is less than the logical record length, the record is padded on the end with blanks (ASCII Format) or zeros (Binary Format).
Rewind	The current record pointer is set to zero.
Backspace Record	The current record pointer is decremented by one. If already ZERO, it is left unchanged and EOF status is returned.
Forward Space Record.	The current record pointer is incremented by one. If already equal to one less than the number of logical records in the file, it is left unchanged and EOF status is returned.
Forward Space File Mark	The current record pointer is set to the number of logical records in the file.
Backspace File Mark	The current record pointer is set to zero.

Status Definition

Status	Meaning
X'00'	Normal completion.
X'90'	End of Medium (EOM). No space available on volume for new index or data block
X'88'	End of File (EOF) Attempt to set current record pointer to value greater than the number of records in file (write request only), to a value equal to or greater than the number of records in the file, or less than zero.
X'84'	Unrecoverable error during physical Read or Write.
X'82'	Data transfer error after 5 retries during physical Read or Write.

NOTE

Control is not returned to the task on I/O Proceed requests until completion of the request. Shared Write access is not permitted to an Index file. If a Shared Write access privilege (SRW, SWO, ERSW) is requested to an Indexed file, the system automatically grants exclusive Write access, if possible.

TELETYPE KEYBOARD/PRINTER

Supported Devices

Device	Product Number	Device Code
M33 Teletype Keyboard/Printer	M46-000/2/4/5	16(10)
M35 Teletype Keyboard/Printer	M46-001/3	17(11)
Non-edit CRT. current loop interface	M46-100/1	18(12)
Carousel 30/35 80 Char/line	M46-010/015/011/016	21(15)
Carousel 30/35 132 Char/line	M46-010/015/011/016 with M46-880	22(16)

Supported Attributes

Read, Write, Wait, Unconditional Proceed, Image, Interactive, Halt I/O
Variable Record Length up to 72 characters (16), 80 characters (17, 18, 21), 132 characters (22)

Functional Description

- Read ASCII.** Data read is masked to 7-Bit ASCII. Data is read until the buffer is full, or a carriage return is found, whichever occurs first. Upon termination, a Carriage Return-Line Feed sequence is sent to the printer. Typing the character '#' causes the line input to be ignored, a Carriage Return-Line Feed sequence to be output, and the Read operation to be restarted. Typing the character '←' or the BS character, causes the previous character entered to be ignored.
- Write ASCII.** The buffer is scanned to eliminate trailing blanks. Data is then output until the buffer is exhausted or until a carriage return is found in the data stream. A line feed is automatically appended to the detected Carriage Return, or if no Carriage Return was detected, a Carriage Return-Line Feed sequence is output.
- Read or Write Image.** None of the above formatting actions occur. The amount of data requested is typed out or read in, without masking to 7-Bit ASCII, eliminating trailing blanks, checking for '#', '←' or BS characters, or detecting or appending carriage returns or line feeds. On Image read, however, a Carriage Return is detected as an end-of-line sentinel.

Status Definition

Status	Meaning
X'00'	Normal Completion
X'82'	Time out or Line Break
X'84'	Unrecoverable Error
X'A0'	Device Unavailable

NOTE

The Reader/Punch of an ASR TTY is treated as a separate device but may not be active at the same time as the Keyboard/Printer.

TELETYPE READER/PUNCH

Supported Devices

Device	Product Number	Device Code
M33 TTY Reader/Punch	M46-000/2/4/5	81 (51)
M35 TTY Reader/Punch	M46-001/3	82 (52)
Carousel 35 Reader	M46-821	83 (53)

Supported Attributes

Read, Write (except for Carousel Reader), Binary, Wait, Unconditional Proceed, Image, Halt I/O
Variable Length Records.

Functional Description

- Read ASCII.** An X-ON character is output to turn the reader on. Tape is read in blocked mode so data is not printed on the printer while it is being read. Leading blank frames and Delete characters are ignored. Data is masked to 7-Bit ASCII. The transfer is terminated on buffer full or Carriage Return, whichever occurs first. On termination of the transfer, tape is advanced to the next Delete character or blank frame. An X-OFF character is output to stop the tape.

Read Binary: An X-ON character is output to turn on the tape. Tape is skipped until the first non-blank frame is found. If the first non-blank character read is a X'FO', the following frames are read in until the user buffer is full. This is non-zoned binary format. If the first non-blank character read is not a X'FO', zoned binary mode is assumed. In this case, the characters are read, stripped of the zones and packed into the user buffer until buffer full. In this mode the only valid punches are X'90', X'81'-X'84', X'95'-X'9F'. Other characters are ignored. On buffer full, the tape is advanced to the next blank frame in zoned binary mode. Note that in unzoned binary, the first character transferred to the user buffer is the character following the X'FO' character, while in zoned binary, the first non-blank frame is transferred (after stripping and packing). After the request is satisfied, an X-OFF is output to turn off the reader.

Read Image None of the above formatting operations is performed. An X-ON character is output to turn the tape on, data is read until user buffer full, the X-OFF character is output to turn the tape off and the transfer is complete

Write ASCII The driver outputs a RUBOUT-TAPE-RUBOUT-RUBOUT sequence in order to initialize the TTY reperforator. Eight frames of blank tape are output as leader, the user data is output until buffer empty or Carriage Return, whichever occurs first. The driver ensures that a CR-LF-TAPE OFF-RUBOUT sequence terminates the record

Write Binary The driver outputs a RUBOUT-TAPE-RUBOUT-RUBOUT sequence, followed by eight blank frames of leader. The user buffer is output, translating each byte into two frames of zoned binary data. The transfer is terminated on buffer empty. The driver then outputs a TAPE OFF-RUBOUT sequence.

Write Image: None of the above formatting or control operations are performed. The user buffer is output until buffer empty.

Status Definition

Status	Meaning
X'00'	Normal completion
X'A0'	Device unavailable
X'84'	Data transfer error.
X'82'	Break detected during transfer. Timeout.

NOTE

On ASCII or Image write, it is possible to turn off the punch inadvertently by outputting a TAPE OFF character. On Image write it is the responsibility of the user to place the necessary control characters, such as TAPE and TAPE OFF in the user buffer to control the operation of the tape.

Since the Reader/Punch portion of the TTY is connected to the Keyboard/Printer portion, only one of these devices may be active at a time. On ASCII write, the data punched on the tape is also printed on the printer.

LOCAL CRT

Supported Devices

Device	Product Number	Device Code
Non Editing CRT (PALS or PASLA)	M46-100/1	34(22)
Graphic Display Terminal (PALS or PASLA)	M46-108/9	36(24)
Carousel 300 Keyboard/Printer (PALS or PASLA)	M46-803/4	37(25)
Carousel 300 Keyboard/Printer Electronic Format Control	M46-803/4 with M46-887	38(26)

All are supported via PALS or PASLA, M46-106 null modem (cable).

Supported Attributes

Read, Write, Wait, Unconditional Proceed, Image, Interactive, Halt I/O.
Variable length records up to 80 characters (34, 36), 132 characters (37, 38).

Functional Description

- Read ASCII** Data read is masked to 7-Bit ASCII. Data is read until the buffer is full, or a Carriage Return is found, whichever occurs first. Upon termination, a Carriage Return-Line Feed sequence is sent to the printer. Typing the character '#' causes the line input to be ignored, an LF/CR/CR sequence to be output, and the Read operation to be restarted. Typing the character "←", or the character BS, causes the previous character entered to be ignored.
- Write ASCII** The buffer is scanned to eliminate trailing blanks. Data is then output until the buffer is exhausted or until a Carriage Return is found in the data stream. A Line Feed is automatically appended to the detected Carriage Return or if no Carriage Return were detected, a LF/CR/CR sequence is output.
- Read or Write Image** None of the above formatting actions occur. The amount of data requested is typed out or read in, without masking to 7-Bit ASCII, eliminating trailing blanks, checking for '#', '←', or BS characters, or detecting or appending Carriage Returns or Line Feeds. On Image read, however, as ASCII Carriage Return is detected as an end-of-line sentinel.

Status Definition

Status	Meaning
X'00'	Normal Completion
X'82'	Time out or Break.
X'84'	Unrecoverable I/O Error.
X'A0'	Device Unavailable.

HIGH SPEED PAPER TAPE READER/PUNCH

Supported Devices

Device	Product Number	Device Code
High Speed Paper Tape Reader/Punch	M46-242/3	80(50)

Supported Attributes

Read, Write, Binary, Wait, Unconditional Proceed, Image Variable record length.

Functional Description

- Read ASCII.** Leading blank tape and delete characters are ignored. Data is masked to 7-Bit ASCII. Carriage Return terminates Read. On termination, the tape is advanced until blank tape or a Delete character is read.
- Read Binary:** Tape is advanced until a non-zero character is read. If this character is X'F0', the tape is read until the buffer is full (Unzoned binary). If the first non-zero character is not X'F0', the tape is treated as a zoned binary tape. Each two characters are stripped of their zone and merged into one byte and placed in the buffer until buffer is full. On buffer full, the tape is advanced until blank tape is found. In zoned binary mode the only valid characters are: X'90', X'81'-X'84', X'95'-X'9F'. All other characters cause the transfer to end with unrecoverable status.
- Read Image.** Tape is read until buffer is full. None of the above formatting or control operations are performed.
- Write ASCII** Eight frames of blank tape are output. The user buffer is output up to (but not including) Carriage Return or until buffer empty. Carriage Return-Line Feed is then output.
- Write Binary:** Eight frames of blank tape followed by the character X'F0' are output. The user buffer is output until buffer empty.
- Write Image** The user buffer is output until buffer empty. None of the above formatting or control operations are performed.

Status Definition

Status Returned	Meaning
X'00'	Normal Completion
X'A0'	Device Unavailable
X'82'	Time-out
X'84'	Transfer Error or invalid zone character

LINE PRINTER

Supported Devices

Device	Product Number	Device Code
Low Speed (200 LPM) Line Printer	M46-204/5/207/8	112(70)
High Speed (600 LPM) Line Printer	M46-209/10	114(72)

Supported Attributes

Write, Wait, Unconditional Proceed, Image Variable record length up to 132 bytes.

Functional Description

Write ASCII The user buffer is output until a Carriage Return is found or until the buffer is empty. At the termination of the buffer, the system takes all necessary action to ensure that the buffer is printed and the paper spaced upwards one line. If form-feed or any other paper motion is desired, the appropriate characters must appear in the user's buffer.

Write Image: The user buffer is output exactly as found in memory. No action is taken by the system to ensure that the data is printed or that the paper is properly moved. The user should be familiar with the characteristics of the particular device being used.

Status Definition

Status	Meaning
X'00'	Normal Completion.
X'A0'	Device Unavailable Device not ready. Form error.
X'84'	Device became unavailable during transfer

NOTE

Although the Low and High Speed Line Printers have different form control characters, the sequence Carriage Return, X'01' causes a new line to be started on each printer. This sequence is used for Write ASCII to allow program compatibility using the same driver.

CARD READER

Supported Devices

Device	Product Number	Device Code
Card Reader Interface Without Translation	M46-235	96(60)
Card Reader Interface With Translation	M46-235 with M46-234	97(61)

Supported Attributes

Read, Wait, Unconditional Proceed, Image. Fixed record length 80 bytes (ASCII), 160 bytes (Image)

Functional Description

Read ASCII: Each card column (12 bits) is converted into one 7-Bit ASCII character. Illegal codes are converted into the null character (X'00').

Read Image Each column is converted into one halfword with the following format:

bit	0	1	2	3	4	5	6	7
card column	U	U	12	11	0	1	2	3
bit	8	9	10	11	12	13	14	15
card column	U	U	4	5	6	7	8	9

U = undefined

Status Definition

Status	Meaning
X'00'	Normal end of transfer.
X'A0'	Device unavailable. Reader not ready; Hopper empty or Stacker full
X'84'	Data Transfer error (Read check or Pick check)

MOVING HEAD DISC

Supported Devices

Device	Product Number	Device Code
2.5 Mbyte Removable Cartridge	M46-445/6	49(31)
5.0 Mbyte Fixed Cartridge	M46-440/1	50(32)
5.0 Mbyte Removable Cartridge	M46-440/1	51(33)
40 Mbyte Removable Cartridge	M46-429/30	52(34)
67 Mbyte Removable Cartridge	M46-600/2	53(35)
256 Mbyte Removable Cartridge	M46-604/6	54(36)

Supported Attributes

Read, Write, Binary, Wait, Random, Unconditional Proceed, Image Variable Length Records.

Functional Description

Read: A current sector pointer is maintained. On a sequential read, data is read from the disc starting at the current sector into the user buffer until the buffer is full. If an attempt is made to read beyond the end of the disc, end of medium status is returned. On a random request, the data is read from the disc starting at the sector specified by the random sector address passed with the request, until buffer full. ASCII, Binary, and Image requests are treated identically.

Write: Data is written from the user buffer to the disc, starting at the current sector for sequential writes or at the specified sector for random writes, until buffer empty. Attempts to write past the end of the disc cause end of medium status to be returned. In this case, no data is transferred.

Errors on data transfers cause the operation to be retried ten times before returning error status.

All data transfers start on a sector boundary but may end on any byte of a sector.

Status Definition

Status	Meaning
X'00'	Normal completion.
X'A0'	Request could not be started, device not ready.
X'90'	End of medium. Transfer ends beyond the end of the disc.
X'88'	Pseudo end of filemark read. This status is only returned on request by the OS/16 File Manager.
X'84'	Seek incomplete. All device errors other than data transfer error.
X'82'	Data transfer error after ten retries. Write protection violation. Timeout.

NOTE

The Moving Head Disc Driver is designed for use by the OS/16 MT2 File Manager. The Disc Driver cannot be invoked by a user program unless it is an E-task. For user tasks, the disc is accessed by means of the Contiguous or Indexed file handlers discussed in the first section of this chapter.

The 10 Mbyte Disc System, Product Number M46-440/1, is supported in OS/16 as two 5.0 Mbyte cartridges, one fixed and one removable. Since there is only one seek mechanism, the two discs on a 10 Mbyte system share a busy flag and only one disc may be active at any instant in time.

FLOPPY DISC

Supported Devices

Device	Product Number	Device Code
Floppy Disc Drive	M46- (TBD)	55(37)

Supported Attributes

Read, Write, Binary, Wait, Random, Unconditional Proceed, Variable Length Records

Function Description

Read: A current sector pointer is maintained. On a sequential read, data is read from the disc starting at the current sector into the user buffer until the buffer is full. On a random request, the data is read from the disc starting at the sector specified by the random sector address passed with the request, until the buffer is full. If an attempt is made to read beyond the end of the disc, end of medium status is returned with no data transferred. ASCII, Binary, and Image requests are treated identically.

Write: Data is written from the user buffer to the disc, starting at the current sector pointer (for sequential writes) or at the specified sector (for random writes), until buffer empty. If an attempt is made to write beyond the end of the disc, end of medium status is returned with no data transferred. ASCII, Binary, and Image requests are treated identically.

Errors on data transfers cause the operation to be retried ten times before returning error status.

All data transfers start on a logical 256 byte sector boundary (two physical sectors on the disc). A transfer may end on any byte of a sector.

Status Definition

X'00'	Normal completion.
X'A0'	Request could not be started, device not ready.
X'90'	End of medium. Transfer ends beyond the end of the disc.
X'88'	Pseudo end of filemark read. This status is only returned on request by the OS/16 File Manager.
X'84'	All device errors other than data transfer error
X'82'	Data transfer error after ten retries. Write protection violation or Time-out.

NOTE

The Floppy Disc Driver is designed for use by the OS/16 File Manager. The Driver cannot be invoked by a user program unless it is an E-task. For user tasks, the disc is accessed by means of the Contiguous or Indexed file handlers discussed in the first section of this chapter.

CASSETTE

Supported Devices

Device	Product Number	Device Code
Intertape Cassette Drive	M46-400	66(42)

Supported Attributes

Read, Write, Binary, Wait, Unconditional Proceed, Image, Rewind, Backspace Record, Forward Space Record, Write File Mark, Forward Space File Mark, Backspace File Mark Variable length Records.

Functional Description

- Read** (ASCII, Binary, and Image modes are identical) Data is read from the cassette into the user's buffer. The transfer terminates at buffer full, or at end of record, whichever comes first. If the record is longer than the buffer, error status is not returned. Parity errors in the unread part of the record, however, may be detected. If a parity error occurs, five retries are attempted before error status is returned. On parity error status return, the tape is positioned in the inter-record gap following the errored record.
- Write.** (ASCII, Binary, and Image modes are identical.) Data is written from the user's buffer until the buffer is empty. The system retries five times on parity errors.

Status Definition

Status	Meaning
X'00'	Normal completion.
X'CO'	Attempt to transfer less than 4 bytes.
X'A0'	Device not ready Tape failed to move at start of request.
X'90'	End of tape on Read, Write or Write File Mark.
X'88'	End of file
X'84'	Device became unavailable during a request.
X'82'	Data transfer error after 5 retries; time-out.

NOTE

The driver cannot distinguish between Beginning Of Tape (BOT) and End Of Tape (EOT) conditions. Either condition generates an End Tape (ET) condition. If ET is detected on a request, with no previous request which causes forward motion, then BOT is assumed. The user should ensure that a cassette is not loaded at End Of Tape unless that condition is expected

Since the two drives on an Intertape Cassette share logic, a shared busy condition exists and only one drive of a cassette pair (e.g. X'45' and X'55') may be active at a time. Also Keys and Access Privileges are shared so the two drives may not be assigned with incompatible privileges.

Continuous mode operations are used where allowed when requests are passed to the driver within the time required (10-milliseconds for Read, 30 milliseconds for Backspace).

9 TRACK MAGNETIC TAPE

Supported Devices

Device	Product Number	Device Code
9 Track 800 Bpi Magnetic Tape Interface	M46-470	64(40)
9 Track 1600 Bpi Magnetic Tape Interface	M46-475	65(41)

Supported Attributes

Read, Write, Binary, Wait, Unconditional Proceed, Image.
Rewind, Backspace Record, Forward Space Record, Write File Mark, Forward Space File Mark,
Backspace File Mark, Variable Length Records

Functional Description

Read: Data is read into the user buffer from the magnetic tape. The transfer ends on buffer full or end of record, whichever comes first. If the record is longer than the user buffer, error status is returned. This error status is indistinguishable from true parity error. On a parity error, five retries are attempted before error status is returned. After a parity error the tape is positioned in the inter-record gap following the errored record.

Write: Data is written from the user buffer to the magnetic tape until the buffer is empty. Five retries are attempted on parity error.

For both Read and Write requests, ASCII, Binary, and Image requests are identical.

Status Definition

Status	Meaning
X'00'	Normal completion.
X'A0'	Device not ready. Tape unavailable at the start of request for data transfer.
X'90'	End of tape. Request caused the reflective marker at end or beginning of tape to be sensed.
X'88'	End of file. Filemark detected during request.
X'84'	Device became unavailable during request.
X'82'	Data transfer error after 5 retries. Timeout occurs.

NOTE

The driver cannot distinguish between Beginning Of Tape (BOT) and End Of Tape (EOT) conditions. Either condition generates an end tape (ET) condition. The driver assumes that if ET is detected on a Write request that the tape is at BOT. Issuing a Write request at EOT will hang up the controller such that no further interrupts may be serviced. If rewind is issued at BOT, the driver simply returns normal status. The user should ensure that the tape is loaded at BOT unless some other condition is expected. Backspace File Mark to a tape with no filemarks between the position of the tape and the point of BOT also hangs up the controller. The Processor Initialize key must be used to clear this condition if no clock exists to time out the driver.

7-TRACK MAGNETIC TAPE

Supported Devices

Device	Product Number	Device Code
7 Track 800 Bpi Magnetic tape interface	M46-474	67(43)

Supported Attributes

Read, Write, Binary, Wait, Unconditional Proceed, Image Rewind, Backspace Record, Forward space. Record, Write File Mark, Forward Space File Mark, Backspace File Mark. Variable Length Records.

Functional Description

Read: Data is read into the system buffer from the magnetic tape. This buffer is 342 bytes long. The transfer ends on buffer full or end of record, whichever comes first. If the record is longer than the system buffer, error status is returned. This error status is indistinguishable from the parity error. On a parity error, five retries are attempted before error status is returned. After a parity error the tape is positioned in the inter-record gap following the errored record.

If no error occurs, the record is then formatted as follows:

Read ASCII: Each byte from the system buffer is converted to 7-bit ASCII and stored in the user buffer. This conversion continues until end of user buffer or end of record, whichever comes first.

Read Binary	Every 4 bytes from the system buffer are converted to three 8-bit binary bytes and are stored in the user buffer. This conversion continues until end of user buffer or end of record, whichever comes first
Read Image	Data is read directly from the magnetic tape into the user buffer. None of the previously described conversions take place.
Write ASCII	Each byte from the user buffer is converted to 6-bit CDC compatible 7 track code. Bytes other than carriage return X'0D' outside the range X'20'--X'5F' are converted to blanks and error status is not returned. If the size of the user buffer is larger than 342 bytes, illegal function status is returned. After the described conversion, the system buffer is written to the tape. Five retries are attempted on parity error.
Write Binary	Every 3 bytes from the user buffer are converted to four 6-bit bytes and are stored in the system buffer. If the size of the user buffer is larger than 256 bytes, illegal function status is returned. After the described conversion, the system buffer is written to the tape. Five retries are attempted on parity error.
Write Image	Data is written directly from the user buffer onto the magnetic tape. All data bytes are masked to 6 bits by the device. Five retries are attempted on parity error.

Status Definition

Status	Meaning
X'00'	No Errors
X'C0'	Illegal Function – The user's buffer is too long with respect to the length of the system buffer
X'A0'	Device Unavailable – The magnetic tape unit is off-line.
X'90'	End-of-Medium – The end of tape or beginning of tape markers have been detected.
X'88'	End-of-File – A Filemark has been detected
X'84'	Unrecoverable Error – Device became unavailable during request.
X'82'	Recoverable Error – Data transfer error after 5 retries. Timeout occurs.

EIGHT LINE INTERRUPT MODULE

Supported Devices

Device	Product Number	Device Code
Eight Line Interrupt Module	M48-001	128(80)

Supported Attributes

SINT

Functional Description

The Eight Line Interrupt Module provides eight interrupt lines to the processor from external equipment and acknowledges interrupts on a priority basis. Any line may be selectively enabled or disabled. Several lines may be concurrently enabled. An interrupt does not transfer any data, nor is any status given. For details on the functions supported, see the SVC 6 description in Chapter 3.

Status Definition

See SVC 6 error codes in Chapter 3

DIGITAL MULTIPLEXOR

Supported Devices

Device	Product Number	Device Code
Digital Multiplexor	M07-860	129(81)

Supported Attributes

Read, Write, Wait, Unconditional Proceed, Image, Binary, Random.

Functional Description

Read: The second byte of the random address field contains the segment and point number to be read. Data is read from the point specified until the buffer specified by the starting and ending address is full.

Write The second byte of the random address field contains the segment and point number to be written to. Data is written until the buffer specified by the starting and ending address is exhausted.

Status Definition

Status	Meaning
X'00'	Normal completion
X'A0'	Device unavailable

CHAPTER 9

GUIDE TO WRITING DRIVERS

INTRODUCTION

Drivers for non-standard devices may be readily included in OS/16 MT2 provided these drivers are written to conform with those procedures used in writing standard drivers. Standard drivers are designed to minimize the period of time external interrupts are disabled. To this end, all drivers consist of at least two, and sometimes three or four distinct parts. The first part or module required in all drivers, is the initialize routine. In operation, this part of the driver becomes a subroutine of the Executive, which runs with external interrupts enabled. The initialize routine interprets the function code, and in general, performs any preliminary function that can be done with interrupts enabled. The second module of the driver is the interrupt service routine. This is an independent routine, although assembled along with other parts of the driver. The third module which, depending on the type of device and the needs of the user, may not be required, is the termination routine. Like the initialize routine, it becomes a subroutine of the executive and performs such functions as error identification, code conversion, and interpretation of final device status. The fourth module is the abort routine, which stops on-going I/O when a cancel request is made.

The DEVICE CONTROL BLOCK

A fifth module, not technically part of the driver, is required for all devices on the system. This is the Device Control Block (DCB). One DCB is required for each device on the system. However, if the driver is properly coded, only one copy of the driver is needed to control several devices of the same type. The Device Control Block provides external storage locations for the driver. Thus, it is possible, using indexed instructions when referring to the DCB, for the driver to handle more than one device. Drivers and system routines reference locations in the DCB with indexed instructions. General Register 14 should always be used as the index register to the DCB. A DCB for each device including user-written driver devices, is automatically generated by the Configuration Utility Program (CUP/16), when the device is configured.

A map of the standard DCB is shown in Figure 9-1. The symbol 'DBxxxx' is the address of the DCB. Reference to elements of the DCB can be made symbolically from the DCB address. The STRUC in Figure 9-2 defined DCB elements. For example, the device code at DCB-18 may be referred to by DCB.DCOD(R14). The following section discusses DCB elements as pertains to user-written drivers.

DCB RECL	-22	MAXIMUM RECORD LENGTH		
DCB.CNTS	-20	DCB.WCNT WRITE COUNT	DCB.RCNT READ COUNT	
	-18	DCB.DCOD DEVICE CODE	DCB.DN DEVICE NO.	
DCB.ATRB	-16	ATTRIBUTES		
DCB.KEYS	-14	DCB.WKEY WRITE KEY	DCB.RKEY READ KEY	
DCB.BUSY	-12	DCB.SBSY	A(BUSY FLAG)	
DCB.TERM	-10	A(TERM ROUTINE)		
DCB.ALOC	-8	A(ABORT ROUTINE)		
DCB.TOUT	-6	TIME-OUT COUNT		
DCB.FLGS	-4	FLAGS		
DCB.INIT	-2	A(INITIALIZATION ROUTINE)		
DCB.OPSW	0(0)	OLD PSW		DBxxxx
DCB.NPSS	4(4)	NEW PSW STATUS		
DCB.ENTR	6(6)	STM	R8,IORSAV	
		LM	R8,REG8xxxx	
DCB.LEAV		BR	R15	
		STM	R8,REG8xxxx	
DCB.NOPI		LM	R8,IORSAV	
		LPSW	DBxxxx	
DCB.RSAV	28(1C)	R2	CALLER TCB POINTER AND I/O WAIT POINTER	DCB.IOW
	30(1E)	R3	A(PARBLK)	
	32(20)	R4	FUNCTION CODE AND LU	
	34(22)	R5	MAY BE USED BY DRIVER	
	36(24)	R6	DEVICE NUMBER	
	38(26)	R7	STATUS	
	40(28)		R8-R13	
	52(34)	R14	A(DCB)	
DCB.ISR	54(36)	R15	A(ISR)	
DCB.RES	56(38)		BUSY FLAG	

Figure 9-1. Device Control Block Map

DCB.RECL	EQU	-22	LOGICAL RECORD LENGTH	-2B
DCB.CNTS	EQU	-20	COUNTS	-2B
DCB.WCNT	EQU	-20	WRITE COUNT	-1B
DCB.RCNT	EQU	-19	READ COUNT	-1B
DCB.DCOD	EQU	-18	DEVICE CODE	-1B
DCB.DN	EQU	-17	DEVICE #	-1B
DCB.ATRB	EQU	-16	DEVICE ATTRIBUTES	-2B
DCB.KEYS	EQU	-14	KEYS	-2B
DCB.WKEY	EQU	-14	WRITE KEY	-1B
DCB.RKEY	EQU	-13	READ KEY	-1B
DCB.BUSY	EQU	-12	A (BUSY FLAG)	-2B
DCB.SBSY	EQU	-12	A (SELCH BUSY FLAG)	-2B
DCB.TERM	EQU	-10	A (TERMINATION ROUTINE)	-2B
DCB.ALOC	EQU	- 8	ABORT LOC	-2B
DCB.TOUT	EQU	- 6	TIME OUT COUNT 0=TIMED OUT	-2B
DCB.FLGS	EQU	- 4	FLAGS HALFWORD	-2B
DCB.INIT	EQU	- 2	A (INITIALIZATION ROUTINE)	-2B
	STRUC			
DCB.OPSW	DS	4	OLD PSW SAVE AREA	
DCB.NPSS	DS	2	NEW PSW STATUS	
DCB.ENTR	DS	10	INTERRUPT SERVICE ENTRY POINT	
DCB.LEAV	DS	4	INTERRUPT SERVICE EXIT LOCATION	
DCB.NOPI	DS	8	NOP ISR ENTRY	
DCB.IOW	EQU	*+1	I/O WAIT POINTER	-1B
DCB.RSAV	DS	14*2	SAVE AREA FOR REGISTERS 2-15	
DCB.ISR	EQU	*-2	ISR POINTER (R15)	-2B
DCB.RES	DS	2	RESERVED FOR BUSY FLAG	
	FLAGS MASKS			
DFLG.BLM	EQU	X'8000'	BULK DEVICE FLAG	
DFLG.LNM	EQU	X'4000'	ON-LINE FLAG	
DFLG.BBM	EQU	X'2000'	BISYNC BUSY FLAG	
DFLG.MPM	EQU	X'1000'	BIT MAP PRESENCE	
DFLG.PFM	EQU	X'0800'	PSEUDO FILEMARK CHECK	
DFLG.BMM	EQU	X'0400'	BIT MAP MODIFY FLAG	
DFLG.CNM	EQU	X'0200'	CONSOLE FLAG	
DFLG.BIM	EQU	X'0100'	BISYNC DEVICE FLAG	
DFLG.S6M	EQU	X'0080'	SVC 6 CONNECTABLE DEVICE	
DFLG.WPM	EQU	X'0040'	WRITE PROTECT FLAG	
DFLG.NSM	EQU	X'0020'	SET=NO SEEK DONE, RESET=SEEK DONE	
DFLG.S1M	EQU	X'0010'	FMGR CALL FROM SVC 1 FLAG	
DFLG.S0M	EQU	X'0008'	START AT ZERO FLAG (GETSEC)	
DFLG.IUM	EQU	X'0004'	DCB IN USE FLAG	
	ATTRIBUTES MASKS			
DATR.INM	EQU	X'8000'	INTERACTIVE DEVICE	
DATR.RDM	EQU	X'4000'	SUPPORTS READ	
DATR.WRM	EQU	X'2000'	SUPPORTS WRITE	
DATR.BIM	EQU	X'1000'	SUPPORTS BINARY	
DATR.WIM	EQU	X'0800'	SUPPORTS WAIT I/O	
DATR.RNM	EQU	X'0400'	SUPPORTS RANDOM	
DATR.UPM	EQU	X'0200'	SUPPORTS UNCONDITIONAL PROCEED	
DATR.IMM	EQU	X'0100'	SUPPORTS IMAGE	
DATR.HIM	EQU	X'0080'	SUPPORTS HALT I/O	
DATR.RWM	EQU	X'0040'	SUPPORTS REWIND	
DATR.BRM	EQU	X'0020'	SUPPORTS BACKSPACE RECORD	
DATR.FRM	EQU	X'0010'	SUPPORTS FORWARD SPACE RECORD	
DATR.WFM	EQU	X'0008'	SUPPORTS WRITE FILEMARK	
DATR.FFM	EQU	X'0004'	SUPPORTS FORWARD SPACE FILEMARK	
DATR.BFM	EQU	X'0002'	SUPPORTS BACKSPACE FILEMARK	
DCOD.NUL	EQU	255	DEVICE CODE OF NULL DEVICE	
	ENDS			

Figure 9-2. DCB – Device Control Block

Maximum Record Length

For user-written drivers, this field is zero since no device record length checking is performed.

Read/Write Count

This field must not be used by the driver.

Device Code

This field contains one of the valid user-written driver device codes (250-254) supplied to CUP/16 with the DEVICE statement.

Device Number

This field contains the physical device address supplied to CUP/16 with the DEVICE statement

Attributes

This field contains the value X'7F7E' for user-written devices – all operations are supported

Bit #	Meaning if set
0	Interactive Device
1	Supports read
2	Supports write
3	Supports binary
4	Supports wait I/O
5	Supports random
6	Supports unconditional proceed
7	Supports image
8	Supports Halt I/O
9	Supports rewind
10	Supports backspace record
11	Supports forward space record
12	Supports write file mark
13	Supports forward space filemark
14	Supports backspace filemark

Keys

This field is initially zero but may be modified by SVC 7 (Write key/Read key – 1 byte each).
This field must not be used by the driver

A (Busy Flag)

This field contains a pointer to the device busy flag.

A (Abort Termination Routine)

This field contains the address of the stop I/O routine (UxxTRM) used by the Executive in terminating I/O in progress.

Time-out Count

This field, initially zero, may be altered by the driver if time-out service is required. The time-out count in seconds is set by the driver when the I/O is initiated and decremented by the clock driver. When the value is zero, the clock driver executes a simulate interrupt instruction on the device, notifying the driver of the device time-out.

Flags

This field is initially set to X'4000' indicating that the device is on-line. Other bits in the flags halfword do not apply to user-written devices.

A(Initialization Routine)

This field contains the address of the driver initialization routine (UxxDVR).

Old PSW

The next locations in the DCB are:

DBxxxx	DC	0,0	OLD PSW STATUS AND LOC
	DC	ISSTAT	NEW STATUS

DBxxxx is the address placed in the Interrupt Service Pointer Table. It points to an old Program Status Word save location where the current PSW is stored on an immediate interrupt.

New Status

The next location is the new status for an immediate interrupt. This status is X'3000' (ISSTAT), machine malfunction and fixed point divide fault interrupts enabled, all others disabled. When the immediate interrupt occurs, the Location Counter is forced to the next location following the new status:

STM	R8,IORSAV	SAVE INTERRUPTED REGISTERS
LM	R8,REG8xxxx	LOAD ISR REGISTERS
BR	RF	BRANCH TO INTERRUPT SERVICE ROUTINE
STM	R8,REG8xxxx	SAVE ISR REGISTERS
LM	R8,IORSAV	LOAD INTERRUPT REGISTERS-DCB.NOPI
LPSW	DBxxxx	RETURN TO INTERRUPT LOCATION

xxxx is the device mnemonic supplied to CUP/16 on the DEVICE statement

In this block of code, the registers in use at the time of the interrupt are saved in IORSAV, a common save area in the Executive. Eight registers must be saved, even if the interrupt service routine does not use that many. This means that the interrupt service routine can only use Registers 8 through 15. REG8xxxx is a location within the DCB.

Register Save Area

The next locations are the register save area.

DC	0	R2	CALLER TCB POINTER AND I/O WAIT POINTER
DC	0	R3	ADDRESS OF PARAMETER BLOCK
DC	0	R4	FUNCTION CODE AND LU
DC	0	R5	
DC	0	R6	DEVICE NUMBER
DC	0	R7	STATUS REGISTER, INITIALLY ZERO
DC	0	R8	
.	.		
.	.		
.	.		
DC	0	RE	ADDR OF DCB
DC	0	RF	ADDRESS OF INTERRUPT SERVICE ROUTINE

It is the responsibility of the driver initialize routine to set up this area. Registers 2, 3, 4, 6, and 7 are loaded by the Executive, but it is up to the driver initialize routine to store them and any other registers it may load for the interrupt service routine. Register 15 is initialized by System Initialization to contain the address of DCB.NOPI. This causes interrupts to be ignored until Register 15 is set up by the driver initialization routine.

Busy Flag

The next location in the DCB is the busy flag. For devices that share a busy flag, the user may modify A(BUSY FLAG) in the DCB to point to a common busy flag. This is done by modifying the output of CUP/16 using OS EDIT.

If a Selector Channel (SELCH) is to be used, then A(BUSY FLAG) should be modified to point to a SELCH busy flag. The SELCH busy flags generated by the system are of the form FFxxBSY where xx is the device number of the SELCH. The following statements appear at the end of the DCB:

```

ORGxxxx    ORG      X'nn'*2+ISPTAB
            DC       A(DBxxxx)
            ORG      ORGxxxx
    
```

In these statements, X'nn' is the device number, and the ORG statement sets the Location Counter of the Assembler to the location in the Interrupt Service Pointer Table where the address of the DCB must be stored. The second ORG sets it back to its previous location. For SELCH devices, the driver itself must set up the correct slot in the Interrupt Service Pointer Table, i.e. `STH R14,X'F0'*2+X'D0'`.

Device codes 240-254 are reserved for user-written drivers. For example, the CUP/16 statement `DEVICE 240,3A,USER:` generates the following DCB:

	EXTRN	U40TRM,U40DVR	DRIVER ABORT ROUTINE AND DRIVER ADDRESS
	ENTRY	DBUSER	DCB ADDRESS
	DC	X'0000',0	MAX RECORD LENGTH, READ/WRITE COUNTS
	DC	X'F03A'	DEVICE CODE, DEVICE NUMBER
	DC	X'7F7E',0	ATTRIBUTES, KEYS
	DC	USERBSY,0,U40TRM,0	ADDRESS OF BUSY FLAG, TERM AND ABORT ROUTINES, TIMEOUT COUNT
	DC	X'4000',U40DVR	FLAGS, ADDRESS OF DRIVER
DBUSER	DC	0,0,ISSTAT	OLD PSW, NEW PSW STATUS
	STM	R8,IORSAV	SAVE REGISTERS ON INTERRUPT
	LM	R8,REG8USER	LOAD DRIVER REGISTERS
	BR	RF	GO TO DRIVER
	STM	R8,REG8USER	SAVE DRIVER REGISTERS
	LM	R8,IORSAV	LOAD INTERRUPTED REGISTERS
	LPSW	DBUSER	RETURN
REG2USER	DC	0,0,0,0,0,0,0	REGISTER SAVE AREA
REG8USER	DC	0,0,0,0,0,0,0,0	
USERBSY	DC	X'00'	BUSY FLAG
ORGUSER	ORG	X'3A'*2+ISPTAB	ORG TO ISP TABLE SLOT
	DC	DBUSER	DEPOSIT DCB ADDRESS
	ORG	ORGUSER	RE-ORG

NOTE

The abort and driver initialization routine addresses are always of the form UxxTRM and UxxDVR where xx is the device code (truncated to two digits) specified in the DEVICE statement.

DRIVER LOGIC FLOW

Figure 9-3 shows the internal flow of an I/O operation starting with the Supervisor Call instruction executed by a running task and ending with the return through the scheduler to activate the highest priority ready task.

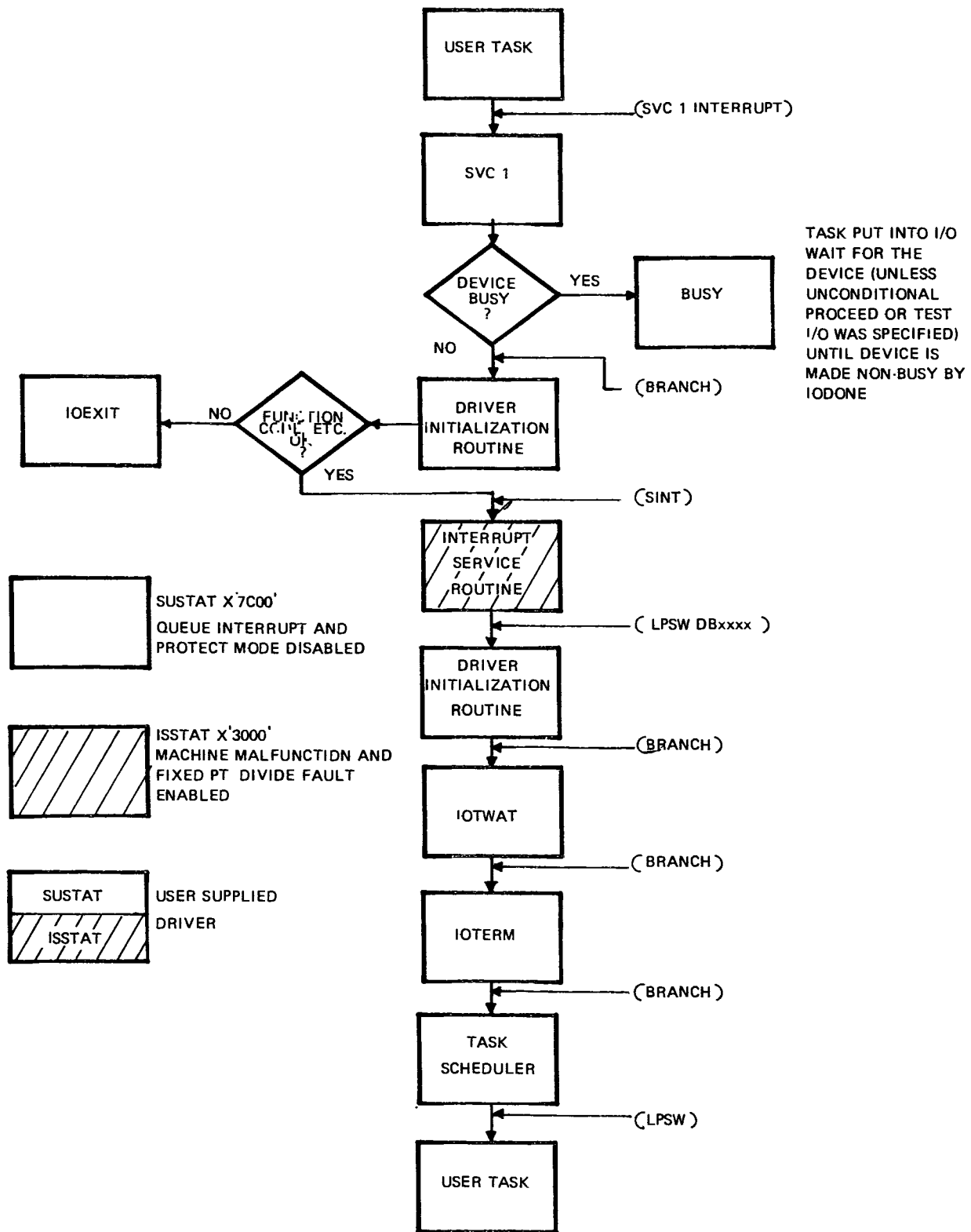
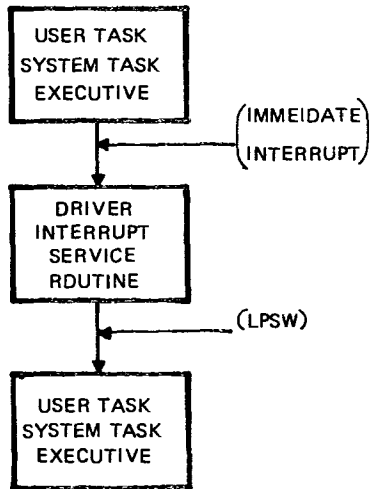

Figure 9-3 Internal Flow

INTERRUPT SERVICE



I/O TERMINATION

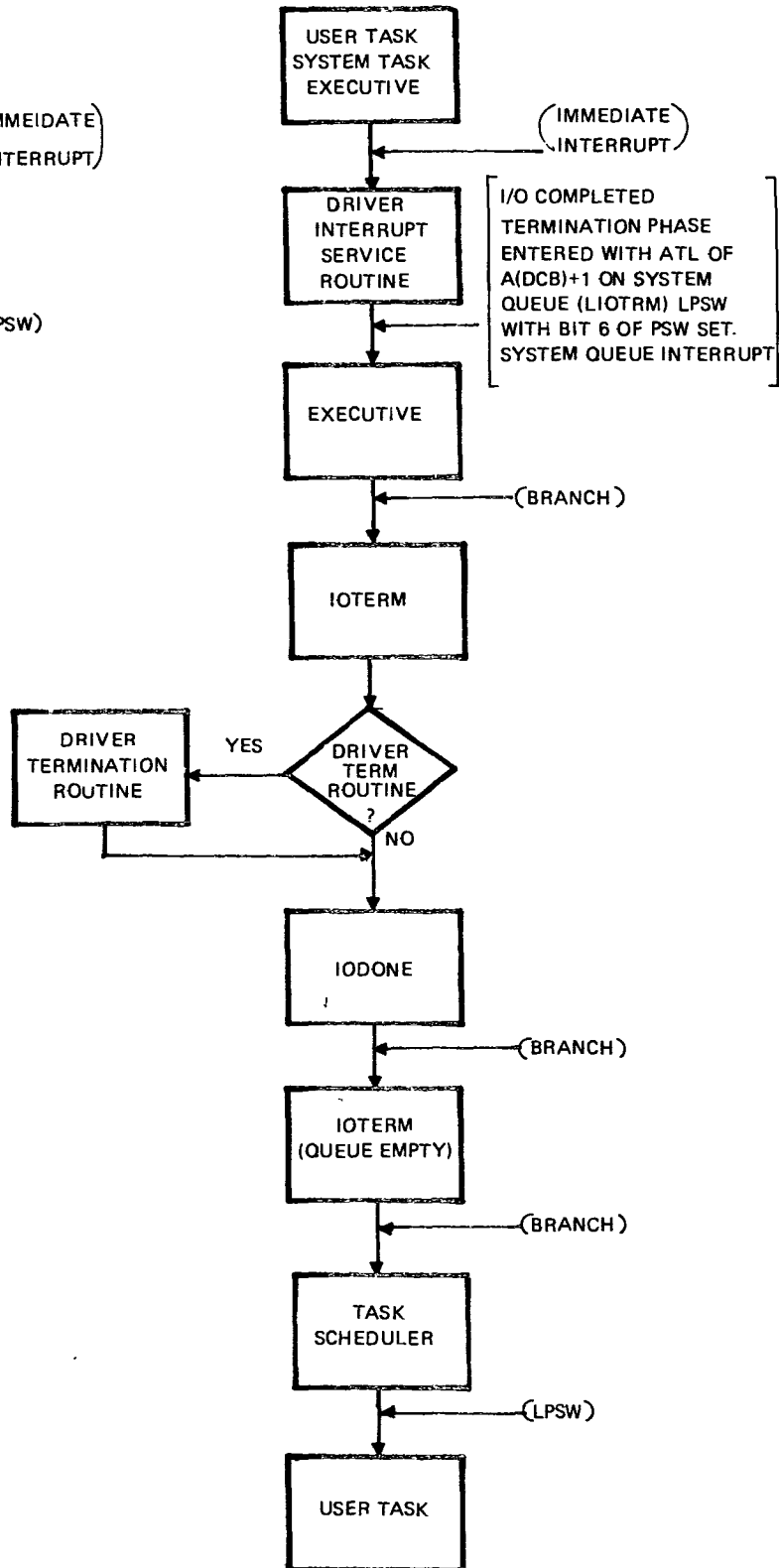

Figure 9-3. Internal Flow (Continued)

SUPERVISOR CALLS

All requests for I/O operations start with a Supervisor Call instruction, such as

SVC 1,PBLK

in which the 1 in the R1 field indicates an I/O request and PBLK in the A(X2) field is the address of a parameter block. The parameter block must consist of a one byte function code and a one byte logical unit number. The meaning of bits within the function code is left for interpretation by the driver with the following exceptions:

1. Bit 0 must signify commands/data transfer
2. Either or Both of Bits 1 and 2 must be on for a data transfer
3. Bit 4 must signify wait or proceed
4. Bit 6 must be used for unconditional proceed

The logical unit number must be less than the SYSGEN parameter UNITS. The second halfword of the parameter block must be reserved as a location in which the system can return ending status and the device number on completion of the operation. The entire parameter block must be within the user designated memory area. If Bit 0 of this function code specifies a data transfer, the length of data transferred (in bytes) is returned in the parameter block. See Figure 9-4 for the SVC 1 parameter block STRUC.

SVC1.	STRUC		
SVC1.FUN	DS	0	FUNCTION CODE/LOGICAL UNIT
SVC1.FC	DS	1	FUNCTION CODE
SVC1.LU	DS	1	LOGICAL UNIT
SVC1.STA	DS	0	STATUS
SVC1.DIS	DS	1	DEVICE INDEPENDENT STATUS
SVC1.DDS	DS	1	DEVICE DEPENDENT STATUS
SVC1.SAD	DS	2	STARTING ADDRESS
SVC1.EAD	DS	2	ENDING ADDRESS
SVC1.RAD	DS	4	RANDOM ADDRESS
SVC1.LXF	DS	2	LENGTH OF LAST TRANSFER
*	FUNCTION CODE		
S1FC.RDM	EQU	X'40'	READ
S1FC.WRM	EQU	X'20'	WRITE
S1FC.BIM	EQU	X'10'	BINARY/ASCII
S1FC.WTM	EQU	X'08'	WAIT/PROCEED
S1FC.RNM	EQU	X'04'	RANDOM/SEQUENTIAL
S1FC.UPM	EQU	X'02'	UNCONDITIONAL PROCEED
S1FC.IMM	EQU	X'01'	IMAGE/FORMATTED
S1FC.CMM	EQU	X'80'	COMMAND FUNCTION
S1FC.RWM	EQU	X'40'	REWIND
S1FC.BRM	EQU	X'20'	BACKSPACE RECORD
S1FC.FRM	EQU	X'10'	FORWARD SPACE RECORD
S1FC.WFM	EQU	X'08'	WRITE FILE MARK
S1FC.FFM	EQU	X'04'	FORWARD FILE
S1FC.BFM	EQU	X'02'	BACKWARD FILE
*	STATUS HALFWORD		
S1ST.ERM	EQU	X'8000'	ERROR STATUS
S1ST.IFM	EQU	X'4000'	ILLEGAL FUNCTION
S1ST.DUM	EQU	X'2000'	DEVICE UNAVAILABLE
S1ST.EMM	EQU	X'1000'	END OF MEDIUM
S1ST.EFM	EQU	X'0800'	END OF FILE
S1ST.UEM	EQU	X'0400'	UNRECOVERABLE ERROR
S1ST.REM	EQU	X'0200'	RECOVERABLE ERROR
S1ST.LUM	EQU	X'0100'	ILLEGAL OR UNASSIGNED LU
	ENDS		

Figure 9-4. SVC 1 Parameter Block

EXECUTIVE ROUTINES

Several Executive routines are involved in starting an I/O operation. Of prime interest to those writing drivers is the SVC 1 handler (SVC1). This routine performs the following functions:

- 1 Save the caller's registers.
- 2 Picks up the logical unit number. The logical unit number must be less than UNITS. If not, the routine returns illegal LU status, X'81', to the caller immediately.
- 3 Gets the DCB address from the task's logical unit table.
- 4 If the function code specifies data transfer (bit 0 reset), it checks the function with the device attribute. If any part of the function is unsupported, it returns illegal function status, X'C0', to the caller immediately. If the function code specifies a command and there are no supported functions (as described in the section entitled Device Control Block) specified, it returns to the caller with normal status.
- 5 Checks the device busy flag. If set, it puts the caller in I/O wait for the device (unless unconditional proceed or test I/O is specified).
- 6 Sets the busy flag for all devices except the disc and a binary synchronous communication line. The address of the DCB is put in the busy flag.
- 7 Branches to the driver. On entry to the driver, the following registers are set up

R1 - Address of DCB
R2 - Caller's TCB Pointer and I/O Wait Pointer
R3 - Address of SVC 1 parameter block
R4 - Function and logical unit
R6 - Device number
R7 - Zero (status register)
R8 - Address of driver

DRIVER INITIALIZE ROUTINE (DIR)

The actual function of the driver initialize routine depends largely on the device. In general, the driver

- 1 Performs further checking on the function code for validity and to determine the type of operation.
- 2 Sets up general registers 8-15 as follows:
R8-13 As needed for later use by the interrupt service routine of the driver
R14 Address of DCB
R15 Address of the interrupt service routine to be entered on the first interrupt
- 3 Stores general registers 2-15 in the DCB at REG2 save area (DCB.RSAV).
- 4 Simulates an interrupt from the device to get to the interrupt service routine where actual I/O instructions can be used.
- 5 Returns to the Executive.

The driver returns to the Executive at one of two locations. If all has gone well, and the interrupt service routine is activated, the driver returns to IOTWAT, a routine in the Executive that takes care of the I/O wait thread before exiting to the Task Scheduler. If the driver determines that there is something wrong with the operation before going to the interrupt service routine, it returns through IOEXIT. On this return, the status register R7 must return with the appropriate status, usually illegal operation, X'C000'. For either return, registers 1, 2, 3, 4, and 6 must be set up as they were on entry to the driver.

INTERRUPT SERVICE ROUTINE (ISR)

The interrupt service routine, like the initialize routine, is very device dependent. It is activated in one of three ways:

- 1 By the initialize routine to start the device (SINT).
- 2 By subsequent interrupts from the device.
- 3 By a Simulate Interrupt from the system (time-out).

Entry to the interrupt service routine is always through an interrupt, either simulated or real. The following sequence occurs on such an interrupt:

- 1 The current PSW is saved in the DCB old PSW save location (DCB.OPSW).
2. The new status, ISSTAT (X'3000', machine malfunction and fixed point divide fault interrupts enabled), is loaded from the new PSW status location of the DCB (DCB.NPSS).
- 3 The location counter points to the next location of the DCB (DCB.ENTR) which contains the sequence:

(DCB.ENTR)	STM	R8,IORSAV
	LM	R8,REG8xxxx
	BR	RF
(DCB.LEAV)	STM	R8,REG8xxxx
(DCB.NOPI)	LM	R8,IORSAV
	LPSW	DBxxxx

The DCB saves eight registers, starting with R8, at the location IORSAV. IORSAV is a reserved area of 16 bytes in the Executive. Then, eight registers are loaded from REG8xxxx, a location within the DCB register save area (DCB.RSAV+12), and the location in Register 15, as set up by the initialize routine is entered. What occurs here is device dependent. Usually, the interrupt service routine issues an output command to the device to get it started and sets up Register 15 for subsequent interrupts. Because only eight registers are saved, the ISR can only use R8-RF. References to R2-R7 can be made by accessing the save area corresponding to the register number in DCB.RSAV. The ISR must not execute any instructions other than list instructions, which cause software traps to be entered, (i.e., Multiply and Divide) as the traps run with external interrupts enabled. The interrupt service routine must exit by branching back to the DCB, either to the second store multiple instruction (DCB.LEAV), or to the second load multiple instruction (DCB.NOPI), depending on whether it has to save any registers. In the case where the interrupt service routine is started by the initialize routine, the load PSW instruction returns control, with external interrupts again enabled, to the initialize routine, at the instruction immediately following the simulate interrupt instruction.

When the interrupt service routine is activated as a result of a subsequent interrupt from the device, it checks device status, performs the necessary operation, and exits through the DCB. On the final interrupt, the interrupt service routine executes an ATL instruction to put the address of the DCB+1 on the I/O termination queue, LIOTRM, and sets up the termination address, (DCB.TERM), if required, before exiting through the DCB.

I/O TERMINATION

The system enters the I/O termination routine, IOTERM, as a result of an I/O termination queue interrupt. This interrupt is generated if there is something in the I/O termination queue, LIOTRM, and the processor executes a LPSW or EPSR instruction in which Bit 6 of the new status is set. The initialize routines, IOTWAT and IOEXIT, described previously, branch directly to IOTERM to avoid the overhead of an extra interrupt that would occur when the Task Scheduler executes a LPSW to schedule a task.

The I/O termination queue interrupt is handled by the Executive, which saves the registers at the time of the interrupt and branches to IOTERM. IOTERM performs the following functions:

1. It removes the bottom entry from the list, LIOTRM.
2. If the list is empty it branches to SCHED, the Task Scheduler.
3. If the item removed is the address of DCB+1, it picks up the address of the driver termination routine from DCB.TERM.
4. It loads Registers 2 through 15 from the DCB. If the address of the driver termination routine is zero, it branches directly to IODONE, described below. However, if the address is non-zero, it puts the address of the termination routine in Register 8, and branches on Register 8.

When IOTERM branches to a driver termination routine, Register 1 contains the address of the DCB, Register 8 contains the address of the termination routine, and the remaining registers contain what was in the DCB locations from which they were loaded

Termination routines, like initialize and interrupt service routines are device dependent. In many cases, they are not required at all, i.e., the action taken by IODONE is sufficient to terminate the operation. The terminate routine can be used for code conversion, special error checking, or any other operations required after the transfer is complete that can be done with external interrupts enabled. Driver termination routines must exit by branching to IODONE.

IODONE

IODONE is the common termination routine in the Executive. It expects Register 1 to contain the address of the DCB, Register 2 to contain the caller pointer, as set up by SVC 1, Register 3 to contain the SVC 1 parameter block address, Register 7 to contain the device independent status, Register 6 to contain the device dependent status, and Register 10 to contain the A(last byte transferred)+1. IODONE returns status and length of data transfer to the caller, takes all tasks in the I/O wait thread for that device out of I/O wait, and clears the I/O wait thread. If the device independent status (contents of Register 7) is non-zero, it returns the device dependent status, contents of Register 6, to the caller along with the device independent status. IODONE exits through IOTERM, to remove all items from the queue, before returning to the Scheduler. Any tasks that were in I/O Wait for the device are now rescheduled by priority.

I/O WAIT

Tasks which require I/O on a device that is busy (and the function code specified neither unconditional proceed nor test I/O) are put on the I/O wait thread for that device (see Figure 9-5). The thread starts in the right byte of REG2xxxx in the DCB. Its contents are the TCB pointer of the next task in the thread. The thread continues through the TCBs of all tasks in the thread. The end of the thread is X'00'.

Register 2 is initialized by SVC 1 with the caller's TCB pointer in the left byte and X'00' in the right byte. It must be saved in REG2xxxx in the DCB by the driver in the initialization phase. The thread is built by SVC 1 as other tasks require that device. The user written driver must maintain the integrity of REG2xxxx. If this location is overwritten the thread is destroyed.

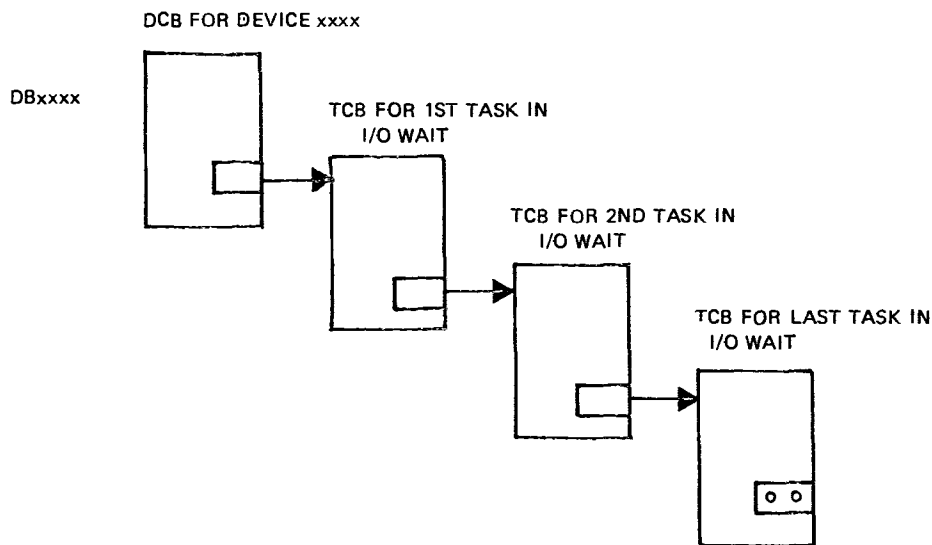

Figure 9-5. I/O Wait Thread

CANCEL I/O

When a task is cancelled, either by a console CANCEL or an SVC 6 task cancel, or goes to End of Task (SVC 3), and I/O is on-going for that task, the EOT routine gets the DCB driver abort routine address (DCB ALOC). It stores it in the Register 15 save area in the DCB (DCB.ISR), and executes a simulate interrupt instruction (SINT). The abort routine is entered in ISSTAT state, (X'3000') with the registers initialized from REG8xxxx (save area in DCB). The logic of the driver abort routine depends largely on the device, but it generally issues a STOP I/O command to the device, sets an unrecoverable error, schedules the I/O termination routine (ATL to LIOTRM), and exits via the DCB (DCB.LEAV).

HALT I/O

When a task requests Halt I/O to a device that supports it, and I/O is on-going, the driver's abort routine is entered, as if the task was cancelled, except that the Halt I/O flag (DFLG.HIM) is set in DCB.FLGS. If the abort routine finds this flag set, it returns Halt I/O error status (X'8281') instead of an unrecoverable error status

SAMPLE DRIVER

The following driver is similar to the standard OS/16 MT2 Card Reader Driver. It is presented as a coding sample for user written drivers. The comments on the listing reflect the functions described in the previous narrative

```
*          THIS PROGRAM IS A CARD READER DRIVER.
*          IT READS UP TO 80 ASCII CHARACTERS
*          OR 160 IMAGE CHARACTERS
*          IT CONVERTS THE HOLLERITH DATA
*          PRODUCED BY AN IBM029 OR
*          IBM 026 KEYPUNCH.
*
*          EXTRN/ENTRY DECLARATIONS
*          EXTRN  LIOTRM,IOTWAT,IODONE,IOEXIT
*          ENTRY  CRDDVR,CRDTRM
*
*          REGISTER ALLOCATION
*          COPY   REGS
*          COPY   DCB
*          COPY   SVC1.
HOLBUF    EQU   DCB.SDN
*          ENTERED HERE ON SVC IF NOT BUSY
*          INITIALIZATION PHASE
CRDDVR    LBR   RD,R6           MOVE DEVICE NUMBER TO RD
          SSR   RD,R0           SENSE STATUS
          THI   R0,X'20'        IS HOPPER EMPTY?
          BZS   CRDVRB          NO READ A CARD
          LHI   R7,X'A000'      HOOPER EMPTY = D. U.
          B     IOEXIT
*
CRDVRB    LHI   RA,HOLBUF(R1)   SET STARTING ADRS OF BUFF
          LIS   RB,2            SET BXH INCREMENT VALUE
          LHR   RE,R1           ADRS OF DCB INTO R14
          LHI   R8,CRTERM       SET UP TERMINATION ROUTINE ADDRESS
          STH   R8,DCB.TERM(RE)
          LHI   RC,159(RA)      SET END ADRS OF CARD BUFF
          LHI   RF,CRISR        SET INTERRUPT SERVICE ROUTINE ADDR
          STM   R2,DCB.RSAV(R1) SAVE DRIVER REGISTERS
          SINT  0(RD)           START I/O OPERATION
          B     IOTWAT          EXIT INITIALIZATION PHASE
*          ON I/O INTERRUPT CONTROL TRANSFERS HERE, INTS DISABLED.
*          INTERRUPTS SERVICE ROUTINE PHASE
CRISR     LHI   RF,CRISR1       SET ISR POINTER
          OC    RD,CFEED        FEED A CARD
          B     DCB.LEAV(RE)    RETURN AND WAIT FOR FIRST INT
```

CRISRI	SSR	RD,R8	CHECK STATUS
	BFC	1,NOTDU	BRANCH IF DEVICE AVAILABLE
CRDTRM	EQU	*	(THE ABORT ROUTINE IS HERE)
ERR	LHI	RB,X'8400'	UNREC ERROR STATUS
	STH	RB,DCB.RSAV+10(RE)	SAVE IT IN R7 SAVE AREA
	XHR	R8,R8	IODONE RETURN
	STH	R8,DCB.TERM(RE)	ZERO TERMINATION ROUTINE ADDR
BACK	OC	RD,DISABL	DISABLE INTERRUPTS
	LHI	RF,DCB.NOPI(RE)	SET NOP ISR
	AIS	RE,1	MAKE DCB ADRS ODD
	ATL	RE,LIOTRM	
	B	DCB.LEAV-1(RE)	RETURN
NOTDU	BNOS	CHKSTS	EXAMINE SET'
	THI	R8,X'DO'	ANY BAD STATUS?
	BNZ	ERR	YES
CHKSTS	SSR	RD,R8	GET STATUS SOON
	NHI	R8,X'20'	YES. HOPPER EMPTY SET?
	BZ	ERR	NO UNREC ERR
BSY	SSR	RD,R8	GET STATUS AGAIN
BSY2	BTC	8,DCB.NOPI(RE)	BSY=1?
	RH	RD,0(RA)	READ 2 BYTES
	BXH	RA,BACK	LOOP FOR ENTIRE CARD
SAVE	STH	RA,DCB.RSAV+16(RE)	SAVE CURRENT BUFFER POINTER ONLY
	B	DCB NOPI(RE)	RETURN
*			
CFEED	DB	X'60'	FEED A CARD
DISABL	DB	X'80'	DISABLE INTS
*			
			TERMINATION ROUTINE -- CONVERT CARD
CRTERM	LH	R8,SVC1.SAD(R3)	GET USER BUFFER START ADDR
	LIS	R9,1	SET BXLE LOOP
	LH	RA,SVC1.EAD(R3)	GET USER BUFFER END ADDR
	LHI	RC,HOLBUF(R1)	GET DRIVER BUFFER ADDR
	THI	R4,X'0100'	ASCII OR IMAGE
	BZS	CRASCI	
*			HERE MOVE DATA DIRECTLY FROM DRIVER BUFFER TO USER BUFFER
	B	LENGTH	
*			
CRASCI	EQU	*	
*			HERE CONVERT EACH HOLLERITH HALFWORD
*			TO AN ASCII BYTE AND STORE IN USER BUFFER
LENGTH	LHR	RA,R8	RA=A(LAST BYTE TRANSFERRED)+1
			USED BY IODONE TO CALCULATE
			LENGTH OF XFER
	B	IODONE	END TERMINATION PHASE

This sample driver can be assembled with the following sequence of commands, assuming the source is on cards

```

LD CAL16
TA .BG
AL CRDDVR.OBJ,IN      ;*ALLOCATE OBJECT FILE
AL SCRAT,IN,80       ;*ALLOCATE SCRATCH FILE
AL CROSS,IN,256      ;*ALLOCATE CROSS FILE
AS 1,CR              ;*ASSIGN INPUT DEVICE
AS 2,CRDDVR OBJ     ;*ASSIGN OUTPUT FILE
AS 3,PR              ;*ASSIGN LIST DEVICE
AS 4,SCRAT           ;*ASSIGN SCRATCH FILE
AS 5,CROSS           ;*ASSIGN CROSS FILE
AS 7,PCB16.CAL      ;*ASSIGN COPY FILE
START                ;*START CAL16

```

SUMMARY OF REGISTER CONVENTIONS

Registers On Entry To Driver

The driver is entered with the following registers set up.

Driver Initialization Routine

R1 = A(DCB)
R2 = caller TCB pointer, left byte
X'00' right byte
R3 = A(SVCI parameter block)
R4 = Function Code, left byte
Logical Unit, right byte
R6 = Device Number
R7 = 0 Status
R8 = A(Driver initialization routine)

Driver Interrupt Service Routine

R8-R15 initialized with REG8xxxx (save area in DCB)

Driver Termination Routine

R2-R15 initialized with REG2xxxx (save area in DCB)

Registers On Entry To Executive

The driver must insure the following registers are set up before branching to the Executive entry points.

IOTWAT

R1 = A(DCB)
R2 = caller TCB pointer, left byte
X'00', right byte
R3 = A(SVCI parameter block)
R4 = Function code, left byte
Logical unit, right byte
R6 = Device number
R7 = 0 status

IOEXIT

Same as IOTWAT except for
R6 = device dependent status
R7 = device independent status

IODONE

R1 = A(DCB)
R2 = caller TCB pointer, left byte
I/O wait pointer, right byte
R3 = A(SVC 1 parameter block)
R6 = device dependent status
R7 = device independent status
R10 = A(last byte transferred)+1
used only on data transfer requests

RTOS DRIVER COMPATIBILITY WITH OS/16 MT2

The following is a list of items for consideration when converting an existing RTOS driver for user under OS/16 MT2

1. The names of the Driver Initialize Routine and the Driver Abort Routine must be of the form xxxDVR and xxxTRM.
2. The abort routine must be modified to return an unrecoverable error for recovery from a power failure.
3. The abort routine may be modified to support Halt I/O, if desired
4. Branching to DCB LEAV always saves R8-RF. If fewer registers are to be saved, the ISR must save them itself and exit to DCB NOPI.
5. When IODONE is entered, RA must contain the address of the last byte transferred plus one, or the SVCI LXF field will not be set up properly

APPENDIX 1

SVC SUMMARY

General form of an SVC instruction is:

SVC N, P

N -- Particular SVC number

P -- Effective address of parameter block or parameter

SVC parameter blocks must be aligned on a halfword boundary.

<u>Function</u>	<u>SVC</u>
I/O Requests	SVC 1
Task Control	
Pause self	SVC 2 Code 1
End self	SVC 3 or SVC 6 End Task
Load another foreground task	SVC 6 Load
Start another foreground task	SVC 6 Start
Cancel another foreground task	SVC 6 End task
Send a message to another task	SVC 6 Send Message
Add parameter to another foreground task's Task Queue	SVC 6 Queue parameter
Add parameter to own Task Queue	SVC 6 Queue parameter
Change another foreground task's priority	SVC 6 Change priority
Change own priority	SVC 6 Change priority
Connect Trap Generating Device to task	SVC 6 Connect
Enable Trap Generating Device for interrupts	SVC 6 Thaw
Disable Trap Generating Device interrupts	SVC 6 Freeze
Cause a Trap Generating Device interrupt	SVC 6 SINT
Disconnect Trap Generating Device from task	SVC 6 Unconnect
Delete task from memory	SVC 6 Task Non Resident and End task
Make task memory resident	SVC 6 Task Resident
Load and Start task	SVC 6 Load and Start
Find Task Status	SVC 6 no function
Find Task priority (current)	SVC 6 no function
Find Task ID of self	SVC 2 Code 19
Find Task options of self	SVC 2 Code 19
Find Current TSW for self	SVC 2 Code 19
Find UDL	SVC 2 Code 5
Enable traps	SVC 9
Enable Task Queue entries	SVC 9
Disable Task Queue entries	SVC 9
Wait for trap	SVC 9
Memory Management	
Get storage from allocated memory	SVC 2 Code 2
Return gotten storage to allocated memory	SVC 2 Code 3
Find memory limits for task	SVC 2 Code 5
Fetch overlay into memory	SVC 5
Utility Functions	
Output message to system console	SVC 2 Code 7
Convert from ASCII Hexadecimal to Binary	SVC 2 Code 15
Convert from ASCII Decimal to Binary	SVC 2 Code 15
Convert from Binary to ASCII Hexadecimal	SVC 2 Code 6
Convert from Binary to ASCII Decimal	SVC 2 Code 6
Convert ASCII File Descriptor to SVC 7 format	SVC 2 Code 16
Search for occurrence of ASCII String in a table	SVC 2 Code 17
Move ASCII characters up to some ending character	SVC 2 Code 18
Change PSW Condition Code	SVC 2 Code 4
Disable or Enable Arithmetic Faults	SVC 2 Code 4

Clock Services

Fetch Date (ASCII)	SVC 2 Code 9
Fetch Time (ASCII or Binary)	SVC 2 Code 8
Wait for specified time of day	SVC 2 Code 23
Wait for specified number of milliseconds	SVC 2 Code 23
Take a trap at specified time of day	SVC 2 Code 23
Take a trap in specified number of milliseconds	SVC 2 Code 23
Cancel a time trap	SVC 2 Code 23

File Management

Allocate a direct access file on a device	SVC 7 Allocate
Assign a device/file to a Logical Unit	SVC 7 Assign
Deassign a Logical Unit	SVC 7 Close
Delete a direct access file from a volume	SVC 7 Delete
Change the protection keys of a file	SVC 7 Assign, Reprotect, and Close
Change the name of a direct access file	SVC 7 Assign, Rename, and Close
Change the name of a device (E-task only)	SVC 7 Assign, Rename, and Close
Delete an unconditionally protected file (Keys of FF) (E-task only)	SVC 7 Delete
Flush output buffers of buffered file or device	SVC 7 Checkpoint
Find the maximum record length of device/file assigned to a Logical Unit	SVC 7 Fetch Attributes
Find File Descriptor of device/file assigned to a Logical Unit	SVC 7 Fetch Attributes
Append Data to Indexed File	SVC 7 Assign for EWO or SWO
Find Number of Logical Units available to task	SVC 2 Code 19

SVC 1 -- INPUT/OUTPUT REQUEST

	<u>CAL CODE</u>
	ALIGN 2
PARBLK	DB fc,lu
	DC H'0'
	DAC START
	DAC END
	DC Y'random'
	DAS I
	DC Y'EXTOPT' (ITAM ONLY)

<u>FORMAT</u>	
0(0) FC	1(1) LU
2(2) STATUS	
4(4) A(START)	
6(6) A(END)	
8(8) RANDOM	
12(C) LENGTH OF XFR	
14(E) (4 bytes) EXT.OPT. (ITAM)	

CONDITION CODE

0	NORMAL COMPLETION
F (ALL BITS)	UNCONDITIONAL PROCEED REQUEST FOR BUSY FILE/DEVICE.

SVC 2 CODE 1 – PAUSE

CAL CODE
 ALIGN 2
 PARBLK DB 0,1

<u>FORMAT</u>	
0(0) 00	1(1) 1 (01)

NO OPTIONS SUPPORTED
 CONDITION CODE UNCHANGED.

SVC 2 CODE 2 – GET STORAGE

CAL CODE
 ALIGN 2
 PARBLK DB OPTION,2
 DC H'REG'
 DAC SIZE

<u>FORMAT</u>	
0(0) OPTION	1(1) 2(02)
2(2) REG	
4(4) SIZE	

<u>OPTIONS</u>	<u>MEANING</u>
X'00' –	GET NUMBER OF BYTES SPECIFIED BY SIZE
X'80' –	GET ALL ALLOCATED MEMORY – NUMBER OF BYTES GOTTEN OR RETURNED IN SIZE

REG – SPECIFIES GENERAL REGISTER USED TO RETURN STARTING ADDRESS OF GOTTEN MEMORY.

CONDITION CODE

0 – NORMAL COMPLETION
 4(V-BIT) – REQUESTED SIZE TOO LARGE OR NEGATIVE. REG SET TO ZERO.

SVC 2 CODE 3 – RELEASE STORAGE

PARBLK CAL CODE
 ALIGN 2
 DB 0,3
 DAC SIZE

FORMAT

0(0)	1(1)
00	3(03)
2(2)	SIZE

NO OPTIONS

CONDITION CODE

0
4 (V-BIT)

MEANING

NORMAL COMPLETION
SIZE TOO LARGE OR NEGATIVE

SVC 2 CODE 4 – SET STATUS

PARBLK CAL CODE
 ALIGN 2
 DB OPTION,4
 DB AF,CC

FORMAT

0(0)	1(1)
OPTION	04(04)
2(2)	3(3)
AF	CC

OPTION (HEX)

00
80

MEANING

MODIFY STATUS AND CONDITION CODE
MODIFY CONDITION CODE ONLY

AF BYTE (HEX)

00
10
04
14

MEANING

DISABLE ARITHMETIC FAULTS
ENABLE FIXED POINT DIVIDE FAULT ONLY
ENABLE FLOATING POINT ARITHMETIC FAULT
ENABLE FIXED POINT DIVIDE AND
FLOATING POINT ARITHMETIC FAULTS

CC BYTE (HEX)

0x

MEANING

x IS TO REPLACE CONDITION CODE

CONDITION CODE

VALUE SPECIFIED IN CC BYTE.

SVC 2 CODE 5 – FETCH POINTER

PARBLK CAL CODE
 ALIGN 2
 DB 0,5
 DC H'REG'

FORMAT

0(0) 00	1(1) 5(05)
2(2) REG	

NO OPTIONS

CONDITION CODE
 UNCHANGED

SVC 2 CODE 6 – UNPACK BINARY NUMBER

PARBLK CAL CODE
 ALIGN 2
 DB OPTION+N,6
 DAC DEST

FORMAT

0(0) OPTION+N	1(1) 6(06)
2(2) A(DEST)	

OPTION (HEX)

MEANING

00	CONVERT TO HEXADECIMAL
40	CONVERT TO HEXADECIMAL, SUPPRESS LEADING ZEROS
80	CONVERT TO DECIMAL
C0	CONVERT TO DECIMAL, SUPPRESS LEADING ZEROS

N – LENGTH OF DESTINATION IN BYTES; IF ZERO, 4 IS ASSUMED.

NUMBER TO BE CONVERTED IS PASSED IN GENERAL REGISTER ZERO.

CONDITION CODE
 UNCHANGED

SVC 2 CODE 7 – LOG MESSAGE

PARBLK CAL CODE
 ALIGN 2
 DB OPTION,7 (a)
 DC H'LENGTH' DIRECT TEXT
 DC C'TEXT'

FORMAT

0(0)	1(1)
OPTION	7(07)
2(2)	
LENGTH	
4(4)	
TEXT	

PARBLK CAL CODE
 ALIGN 2
 DB OPTION,7
 DC H'LENGTH' (b)
 DAC TEXT INDIRECT TEXT

FORMAT

0(0)	1(1)
OPTION	7(07)
2(2)	
LENGTH	
4(4)	
A(TEXT)	

OPTIONS (HEX)

00
 40
 80
 C0

MEANING

DIRECT TEXT, FORMATTED
 INDIRECT TEXT, FORMATTED
 DIRECT TEXT, IMAGE
 INDIRECT TEXT, IMAGE

CONDITION CODE

UNCHANGED

SVC 2 CODE 8 – FETCH TIME

PARBLK CAL CODE
 ALIGN 2
 DB OPTION,8
 DAC DEST

FORMAT

0(0)	1(1)
OPTION	8(08)
2(2)	
A(DEST)	

OPTIONS (HEX)

00
 80

MEANING

ASCII FORMAT (hh:mm:ss)
 BINARY FORMAT (4 BYTES–SECONDS SINCE MIDNIGHT)

CONDITION CODE

UNCHANGED

SVC 2 CODE 9 – FETCH DATE

PARBLK CAL CODE
 ALIGN 2
 DB 0,9
 DAC DEST

FORMAT

0(0) 00	1(1) 9(09)
2(2) A(DEST)	

NO OPTIONS – DATE RETURNED IN ASCII mm/dd/yy (or dd/mm/yy according to SYSGEN)

CONDITION CODE
 UNCHANGED

SVC 2 CODE 15 – PACK NUMERIC DATA

PARBLK CAL CODE
 ALIGN 2
 DB OPTION,15
 DC H'REG'

FORMAT

0(0) OPTION	1(1) 15(0F)
2(2) REG	

<u>OPTIONS (HEX)</u>	<u>MEANING</u>
00	HEXADECIMAL
40	HEXADECIMAL, SKIP LEADING BLANKS
80	DECIMAL
C0	DECIMAL, SKIP LEADING BLANKS

BINARY RESULT RETURNED IN GENERAL REGISTER ZERO.
 REG – SPECIFIES GENERAL REGISTER CONTAINING ADDRESS OF ASCII STRING TO BE CONVERTED. RETURNED POINTING TO FIRST BYTE NOT CONVERTED.

<u>CONDITION CODE</u>	<u>MEANING</u>
0	NORMAL COMPLETION
1 (L-BIT)	NO CHARACTERS PROCESSED, GENERAL REGISTER ZERO SET TO ZERO.
4 (V-BIT)	OVERFLOW, MORE THAN 4 HEXADECIMAL DIGITS OR DECIMAL GREATER THAN $2^{16} - 1$ (65,535). RESULT IS VALUE MODULO 10000 (HEX) OR 2^{16} (DECIMAL)

SVC 2 CODE 16 – PACK FILE DESCRIPTOR

PARBLK CAL CODE
 ALIGN 2
 DB OPTION,16
 DC H'REG'
 DAC DEST

FORMAT

0(0) OPTION	1(1) 16(10)
2(2) REG	
4(4) A(DEST)	

<u>OPTIONS (HEX)</u>	<u>MEANING</u>
00	DEFAULT SYSTEM VOLUME
40	DEFAULT SYSTEM VOLUME, SKIP LEADING BLANKS
80	NO DEFAULT VOLUME
C0	NO DEFAULT VOLUME, SKIP LEADING BLANKS

RESULT FORMAT

0(0) VOLUME NAME	
4(4) FILENAME	
12(C) EXTENSION	15(F) BLANK (X'20')

REG = SPECIFIES GENERAL REGISTER POINTING TO ASCII STRING TO BE CONVERTED.
 RETURNED POINTING TO FIRST BYTE NOT CONVERTED

<u>CONDITION CODE</u>	<u>MEANING</u>
0	NORMAL COMPLETION
1 (L-BIT)	NO VOLUME NAME PRESENT IN INPUT
4 (V-BIT)	SYNTAX ERROR
8 (C-BIT)	NO EXTENSION PRESENT IN INPUT
9 (L & C BITS)	NO VOLUME, NO EXTENSION IN INPUT

SVC 2 CODE 17 – MNEMONIC TABLE SCAN

PARBLK CAL CODE
 ALIGN 2
 DB 0,17
 DB REG1,REG2
 DAC TABLE

FORMAT

0(0) 00	1(1) 17(11)
2(2) REG1	3(3) REG2
4(4) A(TABLE)	

NO OPTIONS

REG1 – SPECIFIES GENERAL REGISTER POINTING TO ASCII STRING TO BE SOURCE SCANNED. RETURNED POINTING TO FIRST BYTE NOT IN MNEMONIC.

REG2 – SPECIFIES GENERAL REGISTER USED TO RETURN INDEX OF MATCHED MNEMONIC FROM 0 TO NUMBER OF MNEMONICS – 1. -1 INDICATES NO MATCH.

TABLE – A TABLE OF ASCII MNEMONICS SEPARATED FROM EACH OTHER BY A BYTE OF ZERO. REQUIRED CHARACTERS FOR EACH MNEMONIC ARE INDICATED BY SETTING HIGH ORDER BIT. TABLE TERMINATED WITH TWO CONSECUTIVE BYTES OF ZERO

<u>CONDITION CODE</u>	<u>MEANING</u>
0	NORMAL COMPLETION
4 (V-BIT)	NO MATCH FOUND, REG2 SET TO -1

SVC 2 CODE 18 – MOVE ASCII CHARACTERS

PARBLK CAL CODE
 ALIGN 2
 DB OPTION + N,18
 DB REG1,REG2
 DAC ECSTRING

FORMAT

0(0) OPTION+N	1(1) 18(12)
2(2) REG1	3(3) REG2
4(4) A(ECSTRING)	

<u>OPTIONS (HEX)</u>	<u>MEANING</u>
00	NO ENDING CHARACTERS
80	USE ENDING CHARACTER STRING TO TERMINATE

N – MAXIMUM NUMBER OF CHARACTERS TO MOVE

REG1 – SPECIFIES GENERAL REGISTER POINTING TO ASCII STRING TO BE MOVED. RETURNED POINTING TO FIRST BYTE NOT MOVED.

REG2 – SPECIFIES GENERAL REGISTER POINTING TO DESTINATION. RETURNED POINTING TO BYTE FOLLOWING LAST BYTE MOVED INTO DESTINATION.

ECSTRING – STRING OF TERMINATION CHARACTERS OF FORM:

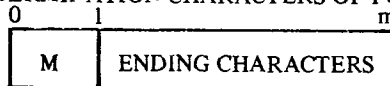

M – NUMBER OF ENDING CHARACTERS

<u>CONDITION CODE</u>	<u>MEANING</u>
0	NORMAL COMPLETION
4 (V-BIT)	NO ENDING CHARACTER FOUND (OPTION X'80')

SVC 2 CODE 19 – PEEK

PARBLK CAL CODE
 ALIGN 2
 DB 0,19
 DS 24

FORMAT

0(0) 00	1(1) 19(13)
2(2) NLU	3(3) MPRI
4(4) OS ID	
12(C) TASK ID	
20(14) CTSW	
22(16) TASK OPTIONS	
24(18) TASK STATUS	

NO OPTIONS

FIELDS RETURNED

- NLU – NUMBER OF LUs AVAILABLE TO TASK
- MPRI – MAXIMUM PRIORITY OF TASK
- OS/ID – ASCII ID OF OS--OS16MT2_r WHERE _r INDICATES REVISION LEVEL
- TASK ID – EIGHT-CHARACTER ASCII TASK ID
- CTSW – STATUS PORTION (FIRST 16 BITS) OF TASK'S CURRENT TASK STATUS WORD
- TASK
 OPTIONS – OPTIONS HALFWORD FROM TASK CONTROL BLOCK
- TASK
 STATUS – STATUS HALFWORD FROM TASK CONTROL BLOCK

CONDITION CODE

UNCHANGED

SVC 2 CODE 23 – TIMER MANAGEMENT

PARBLK CAL CODE
 ALIGN 2
 DB OPTION,23
 DC H'REG'
 DC Y'TIME'

FORMAT

0(0) OPTION	1(1) 23(17)
2(2) REG	
4(4) TIME	

<u>OPTIONS (HEX)</u>	<u>MEANING</u>
80	WAIT FOR INTERVAL COMPLETION
00	PROCEED AND ADD PARAMETER TO TASK QUEUE ON INTERVAL COMPLETION
10	CANCEL TIME INTERVAL
REG –	SPECIFIES GENERAL REGISTER CONTAIN PARAMETER TO BE ADDED TO TASK QUEUE ON COMPLETION OF INTERVAL (OPTION X'00')

<u>TIME – BITS</u>	<u>MEANING</u>
0-3	0000 – SECONDS SINCE MIDNIGHT (TIME OF DAY INTERVAL) 0001 – MILLISECONDS FROM NOW (ELAPSED TIME INTERVAL) OTHER – ILLEGAL
4-31	NUMBER OF CLOCK TICKS IN INTERVAL TICK = 1 SECOND FOR TIME OF DAY INTERVAL 1 MILLISECOND FOR ELAPSED TIME INTERVAL (OPTIONS X'00' AND X'80')

<u>CONDITION CODE</u>	<u>MEANING</u>
UNCHANGED	FOR OPTIONS X'00' AND X'80'
0	FOR OPTION X'10' IF SUCCESSFUL
4(V-BIT)	FOR OPTION X'10' IF NO INTERVAL FOUND

SVC 3 – END OF TASK (EOT)

SVC 3,N

NO PARAMETER BLOCK, SVC EFFECTIVE ADDRESS FIELD (N) STORED IN TASK'S RETURN CODE.

SVC 5 -- FETCH OVERLAY

	<u>CAL CODE</u>	
	ALIGN	2
PARBLK	DC	C'OVLYNM'
	DS	2
	DS	1
	DB	OPTION
	DC	H'LU'

<u>FORMAT</u>	
0(0)	OVERLAY NAME (6 BYTES)
6(6)	RESERVED
8(8)	9(9)
STATUS	OPTION
10(A)	LU

<u>OPTIONS (HEX)</u>	<u>MEANING</u>
01	LOAD FROM SPECIFIED LU WITHOUT POSITIONING
04	LOAD FROM SPECIFIED LU AFTER REWIND

<u>STATUS (HEX)</u>	<u>MEANING</u>
00	NORMAL COMPLETION
10	LOAD FAILED
20	MISMATCH ON OVERLAY NAME
40	OVERLAY WOULD NOT FIT IN ALLOCATED MEMORY

CONDITION CODE

UNCHANGED

SVC 6 – INTERTASK COORDINATION

PARBLK CAL CODE
 ALIGN 2
 DC C'TASK ID'
 DC Y'FUNCTION'
 DS 4
 DB LU
 DB PRI
 DS 2
 DC A(START)
 DC Y'TIME'
 DC C'DEVM'
 DC X'PARM'
 DC A(MESSAGE)
 DS 4

FORMAT

0(0) TASK ID	
8(8) FUNCTION CODE	
12(C) TASK STATUS	
14(E) ERROR STATUS	
16(10) LOAD LU	17(11) PRIORITY
18(12) RPRI	19(13) RESERVED
20(14) START ADDRESS	
22(16) TT DELAY TIME	
26(1A) DEVICE MNEMONIC	
30(1E) PARAMETER	
32(20) MESSAGE BUFFER ADDRESS	
34(22) RESERVED (4 BYTES)	

SVC1 Function Codes

Function Code -- Data Transfer Request

Bit	Alignment	Meaning
0	0	This bit must be ZERO to indicate a data transfer request.
1-2	.xx. . . .	Read-Write bits. The meaning of these two bits is modified by Bits 3-7 to control the transfer. Basically the values are: 10 – Read request 01 – Write request 11 – Test and Set request (see Chapter 8) 00 – Wait Only or Test I/O Complete
3	. .x	ASCII/BINARY bit. This bit indicates the type of formatting requested if Bit 7 is reset. 0 – indicates ASCII formatting 1 – indicates Binary formatting If Bit 7 is reset, this bit must be ZERO.
4 x . . .	PROCEED/WAIT bit. This bit indicates the action to be taken after the I/O has been initiated 0 – Proceed Indicates that control is to be returned to the task after initiation of I/O. 1 – Wait. Indicates that the task is to be put into I/O Wait until the data transfer is complete
5x . .	SEQUENTIAL/RANDOM bit. 0 – Sequential. Indicates the next logical record is to be accessed. 1 – Random. Indicates the logical record specified by the RANDOM field is to be accessed.
6x .	UNCONDITIONAL PROCEED bit. 0 – indicates the task is to be put into I/O wait until the requested device/file is free. At that time the request is processed 1 – indicates that the request is to be rejected with a condition code of X'F' if the requested device/file is not free.
7x	FORMATTED/IMAGE bit 0 – indicates that the request is to be formatted according to the device/file and the setting of Bit 3. 1 – indicates that no formatting is to be performed (Image mode).

Function Code -- Command Function Request

Bit	Alignment	Meaning
0	1	This bit must be set to indicate a command function request. This bit alone set requests Halt I/O.
1	.x.	Rewind
2	. .x.	Backspace Record
3	. . .x	Forward Space Record
4	. . . x	Write File Mark
5x	Forward Space File
6x	Backspace File
7x	Reserved for driver dependent functions

Error Status Definition (SVC 1)

Bit	Meaning if set to 1	Binary	Hexadecimal
0	Always 1 for error status		
1	Illegal Function	1100 0000	X'C0'
2	Device Unavailable	1010 0000	X'A0'
3	End of Medium	1001 0000	X'90'
4	End of File	1000 1000	X'88'
5	Unrecoverable Error	1000 0100	X'84'
6	Parity or Recoverable Error	1000 0010	X'82'
7	Illegal or Unassigned LU	1000 0001	X'81'

SVC 6 Parameter Block Fields

Byte	Name	Meaning
0-7	Task ID	Name of task; not required if call is self-directed
8-11	Function Code	Specifies desired functions
12-13	Task Status	The wait status halfword of the specified task is returned by the system in this field.
14-15	Error Status	Set to ZERO for normal termination or to error code if error detected
16	Load LU	Specifies LU from which to load the task. Used only for Load function.
17	Priority	Specifies priority for change priority function. May not be 255 (E-tasks). Must be in range 10-249 (U-tasks)
18	RPRI	Set by system to actual priority of specified task.
19		(reserved)
20-21	Start Address	Used only for START functions. specifies address at which to start specified task. If ZERO, signifies normal transfer address, as specified at TET/16 time.
22 (Bits 0-3)	TT	Time Type: indicates type of time delay. Used only for Delay-Start. Legal codes are: 0000 = seconds since midnight 0001 = milliseconds from now.
22-25 (Bits 54-31)	Delay Time	Specifies number of seconds or milliseconds, as defined by TT field, to delay the start operation. Used only for Delay-Start.
26-29	Device Mnemonic	Specifies device affected by Connect, Thaw, SINT, Freeze and Unconnect functions.
30-31	Parameter	Specifies parameter to be queued for Queue parameter function; specifies device parameter for Connect functions.
32-33	A(message)	Specifies address of message buffer for Send Message function.
34-37		(Reserved)

SVC 6 Function Codes

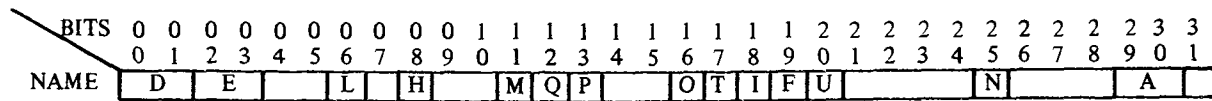

BIT(S)	NAME	HEX MASK	MEANING
0-1	D	8000 0000 C000 0000	Direction 00,01 = illegal codes 10 = other task 11 = self
2-3	E	0000 0000 1000 0000 2000 0000 3000 0000	End Task 00 = no function requested 01 = cancel 10 = delete 11 = delete
4-5	L	0C00 0000	Reserved
6		0200 0000	Load Task
7	H	0080 0000	Reserved
8			Task resident
9-10	M	0010 0000	Reserved
11			Send Message
12	Q	0008 0000	Add parameter to specified task's Task Queue
13	P	0004 0000	Change priority of specified task
14-15			Reserved
16	O	0000 8000	Connect specified device to specified task.
17	T	0000 4000	Thaw: enable interrupts on specified device.
18	I	0000 2000	SINT. Simulate interrupt on specified device.
19	F	0000 1000	Freeze: disable interrupts on specified device.
20	U	0000 0800	Unconnect: disconnect specified device from specified task.
21-24	N	0000 0040	Reserved
25			Task Non-resident
26-28	A	0000 0000 0000 0002 0000 0004 0000 0006	Reserved
29-30			Start task 00 = no function requested 01 = start immediately 10 = delay start 11 = delay start
31			Reserved

SVC 6 Error Codes

The format of the Error Status halfword is as follows:

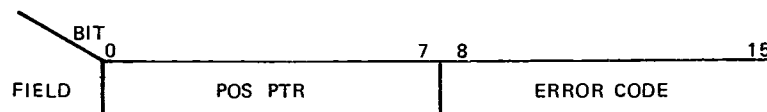

Code Dec (Hex)	Function	Meaning
0(0)	All	No errors; all requested functions complete.
1(1)	All	Syntax error in TASK ID field. Does not apply to self-directed calls
2(2)	--	Illegal function code.
3(3)	L	Task already present.
4(4)	All but L	No such task in foreground.
5(5)	P	Invalid priority.
6(6)	L	Floating point not supported by SYSGEN
7(7)	A	Specified task not dormant.
8(8)	S	Invalid start address.
10(A)	A (delay)	Invalid code in TT field.
11(B)	M	Message not sent, task unable to receive
12(C)	Q	No queue, full queue, or entries disabled.
13(D)	O,T,I,F,U	No such device in system.
14(E)	O,T,I,F,U	Device named is not a connectable device.
15(F)	O	Device is busy, cannot connect.
16(10)	T,I,F,U	Device not connected to specified task.
17(11)	L	Invalid or unassigned Load LU.
18(12)	L	Checksum error.
25(19)	I	Device is not SINTable.
65(41)	L	Partition does not have sufficient number of LUs.
66(42)	L	Resident Library or Task Common not present.
68(44)	L	Invalid format on Loader Information Block.
73(49)	L	Partition not vacant.
74(4A)	L	I/O error during Roll In/out
75(4B)	L	Assign/close error during Roll In/out
76(4C)	L	Partition does not exist.
129-192 (81-C0)	L	I/O error reading Load LU; error status is as returned by SVC 1.

Condition Code

Unchanged

SVC 7 Parameter Block Fields

Command/Modifier

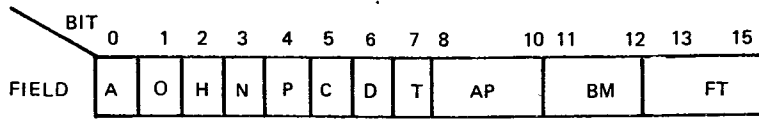

Bits	Name	Hex Mask	Description
0	A	8000	Allocate – requires file type (FT) modifier
1	O	4000	Assign – requires access privilege (AP) and buffer management (BM) modifiers
2	H	2000	Change Access Privilege – requires access privilege (AP) modifiers
3	N	1000	Rename – no modifiers
4	P	0800	Reprotect – no modifiers
5	C	0400	Close – no modifiers
6	D	0200	Delete – no modifiers
7	T	0100	Checkpoint – no modifiers

Bits 0-7 all Zero = Fetch Attributes

8-10	AP	0000	Access Privileges
		0020	SRO – Shared Read Only
		0040	ERO – Exclusive Read Only
		0060	SWO – Shared Write Only
		0080	EWO – Exclusive Write Only
		00A0	SRW – Shared Read-Write
		00C0	SREW – Shared Read-Exclusive Write
		00E0	ERSW – Exclusive Read-Shared Write
11-12	BM	0000	ERW – Exclusive Read-Write
		0000	Buffer Management
		0008	Default Buffer Management
		0010	Unbuffered (Physical)
13-15	FT	0018	Buffered (Logical)
		0000	Reserved
		0000	File Type
		0001	Contiguous
		0002	Reserved (considered illegal)
		0003	Indexed
		0007	Reserved (considered illegal)

SVC 7 Status Byte

ERROR CODE DEC (HEX)	FUNCTION	MEANING
0 (00)	ALL	No error, the requested functions are complete.
1 (01)	A,O,D	Illegal function, illegal file type
2 (02)	All but A,D	LU error; illegal LU
3 (03)	A,O,D	Volume error; no such volume/device in system.
4 (04)	A,O,N,D	Name error; mismatch on filename or extension field.
5 (05)	A	Size error; erroneous LRECL or size field
6(06)	O,P,D	Protect error; erroneous protection keys.
7(07)	All but C,T,F	Privilege error; unable to obtain requested privilege
8 (08)	O	Buffer error; no room in system for file control blocks or buffers.
9 (09)	All but A, O	Assignment error; LU not assigned.
10 (0A)	A,O,N,P,D	Type error; non-direct access device, or device off-line.
11 (0B)	A,O,N,D	File Descriptor error; illegal syntax.
12 (0C)	O	Attempt to assign SVC 6 connectable device.
129-192 (81-C0)	All but F	I/O error; interpreted as SVC 1 status byte.

SVC 7 - FILE MANAGEMENT SERVICES

	<u>CAL CODE</u>
	ALIGN 2
PARBLK	DB CMD
	DB MOD
	DS 1
	DB LU
	DB WKEY
	DB RKEY
	DC H'LRECL'
	DC C'VOLN'
	DC C'FILENAME'
	DC C'EXT'
	DC F'SIZE'

FORMAT

0(0) CMD	1(1) MOD
2(2) STAT	3(3) LU
4(4) WKEY	5(5) RKEY
6(6) LRECL	
8(8) VOLN	
12(c) FILENAME	
20(14) EXT	
23(12) RESERVED	
24(18) SIZE	

SVC 7 REQUIRED FIELDS

FUNCTION	REQUIRED FIELDS										
	CMD	AP	BM	FT	LU	KEYS	LRECL	VOLN	FILEN	EXT	SIZE
ALLOCATE	✓			✓		✓	✓	✓	✓	✓	✓
ASSIGN	✓	✓	✓		✓	✓		✓	✓	✓	
CHANGE ACCESS PRIVILEGE	✓	✓			✓						
RENAME	✓				✓				✓	✓	
REPROTECT	✓				✓	✓					
CLOSE	✓				✓						
DELETE	✓					✓		✓	✓	✓	
CHECKPOINT	✓				✓						
FETCH ATTRIBUTES	✓				✓						

SVC 9 - LOAD TSW

No parameter block; SVC effective address specifies address of TSW to be loaded.

APPENDIX 2

CONTROL BLOCK SUMMARY

TASK STATUS WORD (TSW)

Task Status Word is 32 Bits. First halfword (bits 0-15) contains status defined later. Second halfword (bits 16-31) contains the current location counter as in a PSW.

Bit	Hex Mask	Name	Description
0	8000	W	Trap Wait--task suspended until a task trap occurs
1	4000	P	Power Restoration Trap Enable--a task trap occurs on completion of system power restore sequence.
2-3			Reserved--must be ZERO.
4	0800	Q	Task Queue Service Trap Enable--a task trap occurs when an item is added to the Task Queue. Also a trap occurs if a TSW is loaded with this bit set and the Task Queue is not empty.
5			Reserved--must be ZERO.
6	0200	D	Enable Task Queue entry on interrupt from a connected Trap Generating Device.
7	0100	T	Enable Task Queue entry on Queue Parameter (SVC 6) request directed at this task.
8	0080	Z	Enable Task Queue entry on completion of a time interval.
9	0040	O	Enable Task Queue entry on completion of I/O Proceed request.
10			Reserved--must be ZERO.
11	0010	E	Enable Task Queue entry on task message
12-15	000F	CC	Condition Code (as in PSW).

TASK OPTIONS BITS (TCB)

Bit	Hex Mask	Meaning
0	8000	Executive Task (E-Task) if 1 User Task (U-Task) if 0
1	4000	Arithmetic Fault Continue if 1 Arithmetic Fault Pause if 0
2	2000	Task uses SPFP registers if 1 Task does not use SPFP registers if 0
3	1000	Task is Memory Resident if 1 Task is nonMemory Resident if 0
4	0800	Task uses old SVC 1 format if 1 Task uses OS/16 MT2 SVC 1 format if 0
5	0400	Task is the background task if 1 Task is a foreground task if 0

Bit	Hex Mask	Meaning
6	0200	SVC 6 ignored (Background only) if 1 SVC 6 illegal (Background only) if 0
8	0100	Task is rollable if 1 Task is nonrollable if 0 Reserved for system use
9	0040	Task uses DPF registers if 1 Task does not use DPF registers if 0
10-15		Reserved for system use

TASK STATUS BITS (TCB)

Bit	Hex Mask	Meaning
0	8000	Dormant
1	4000	I/O Wait
2		Reserved
3	1000	Roll Wait
4		Reserved
5	0400	Console Wait (PAUSEd)
6	0200	Time Wait
7	0100	Trap Wait
8	0080	SVC 2 Wait
9	0040	SVC 5/6 Wait
10	0020	SVC 7 Wait
11		Reserved
12	0008	DCB Wait (File I/O Wait)

User Dedicated Locations (UDL)

0 (0)	CTOP	2 (2)	COMBOT
4 (4)	UTOP	6 (6)	UBOT
8 (8)	A(TASKQ)		
10(A)	POWER RESTORE OLD TSW SAVE AREA		
14(E)	POWER RESTORE NEW TSW		
18(12)	TASK QUEUE SERVICE OLD TSW SAVE AREA		
22(16)	TASK QUEUE SERVICE NEW TSW		
26(1A)	A(MESSAGE BUFFER)	28(1C)	RESERVED
26(1A)	RESERVED		
36 (24)	SINGLE PRECISION FLOATING POINT REGISTER SAVE AREA		
68(44)	DDUBLE PRECISION FLOATING POINT REGISTER SAVE AREA		
132(84)			

PCBMT2 - OS/16 MT2 PARAMETERS AND CONTROL BLOCKS PAGE 1 APPENDIX 3
PROG= PCBMT2 ASSEMBLED BY CAL/16 00-00 OS/16 MT2 DATA STRUCTURES
0000R 2 COPY SGN

DEFAULT SYSGEN PARAMETERS

APPENDIX 3 (Continued)

4	5	6	7	8	9	10	11	12	13	14	15	16	17	18	19	20	21	22	23	24	25	26	27	28	29	30	31	32	33	34	35	36	37	38	39	40	41	42	43	44	45	46	47	48	49	50	51	52	54
0000	0001	0000	0040	0001	0010	0002	0000	0000	0000	0000	0000	0001	0000	0001	0001	0000	0000	0000	0000	003C	0000	0001	0000	0000	0001	0001	0000	0003	0000	0001	0001	0000	0000	0000	0000	0000	0000	0000	0000	0001	0001	0001	0001	0001	0001	0001	000A		
* * *	BISYNC	BULKSTOR	CLOCK	CMOLEN	CMPROC	CONS	CONSOLE	CONSPT	CSS	DATE	DEBUG	DFLOAT	DISCMGT	DISP	EFLOAT	FLOAT	FOREGRND	FREQ	INDEX	INITIAL	INTERVAL	JOURNAL	LOG6	LOAD	LOGLEN	LOGQUE	MEMPROT	MULOV	OPTIONS	OVCMD	OVSEVEN	OVSIX	OVTWO	PCLOCK	PFREC	PROC	ROLL	ROUND	SAFE	SETLOG	SETPAR	SVCFIVE	SVCSEVEN	SVCSIX	SVCTWO	UNITS			
0	1	0	64	1	16	2	0	0	1	0	1	1	1	0	0	60	0	0	1	0	0	1	1	1	48	3	0	1	1	0	0	0	1	0	0	0	0	0	0	1	1	1	1	1	10				
EQU	EQU	EQU	EQU	EQU	EQU	EQU	EQU	EQU	EQU	EQU	EQU	EQU	EQU	EQU	EQU	EQU	EQU	EQU	EQU	EQU	EQU	EQU	EQU	EQU	EQU	EQU	EQU	EQU	EQU	EQU	EQU	EQU	EQU	EQU	EQU	EQU	EQU	EQU	EQU	EQU	EQU	EQU	EQU	EQU	EQU	EQU	EQU		
NO BISSYNC SUPPORT	BULK DEVICE COMMANDS INCLUDED	NO LINE FREQUENCY CLOCK SUPPORT	INPUT BUFFER LENGTH	INCLUDE COMMAND PROCESSOR	DEVICE CODE FOR CONSOLE	DEVICE # FOR CONSOLE	NO CONSOLE PAPER TAPE SUPPORT	NO CSS SUPPORT	MM/DD/YY	INCLUDE EXAMINE/MODIFY/BIAS	NO DRPP SUPPORT	DIRECT ACCESS SUPPORT	INCLUDE DISPLAY COMMAND	NO EXTENDED SPFF TRAPS	NO FLOATING POINT SUPPORT	NO FOREGROUND PARTITIONS	60 CPS LINE FREQUENCY CLOCK	NO INDEXED FILE SUPPORT	KEEP SYSINIT	NO PIC INTERVAL	NO SYSTEM JOURNAL	INCLUDE BACKGROUND LOADER	INCLUDE LOAD COMMAND	OUTPUT BUFFER LENGTH	LOG MESSAGE QUEUE SIZE	NO MEMORY PROTECT	INCLUDE MULTIPLY/DIVIDE TRAPS	INCLUDE OPTION COMMAND	DO NOT OVERLAY SVC 7	DO NOT OVERLAY SVC 6	DO NOT OVERLAY SVC 2	NO PIC SUPPORT	INCLUDE POWER FAILURE RECOVERY	NO LIST INSTRUCTION OR MUL/DIV TRAPS	NO ROLL IN/ROLL OUT	NO ROUND ROBIN SCHEDULING	NO SAFETY CHECKS	INCLUDE SET LOG COMMAND	INCLUDE SET PARTITION COMMAND	INCLUDE SVC 5	INCLUDE FILE MANAGER	INCLUDE SVC 6	INCLUDE SVC 2	# OF LOGICAL UNITS PER TASK					
PCB00030	PCB00040	PCB00050	PCB00060	PCB00070	PCB00080	PCB00090	PCB00095	PCB00100	PCB00110	PCB00120	PCB00130	PCB00140	PCB00150	PCB00155	PCB00160	PCB00170	PCB00175	PCB00180	PCB00190	PCB00200	PCB00210	PCB00220	PCB00230	PCB00240	PCB00250	PCB00260	PCB00270	PCB00280	PCB00290	PCB00295	PCB00300	PCB00310	PCB00320	PCB00330	PCB00340	PCB00350	PCB00355	PCB00360	PCB00370	PCB00380	PCB00390	PCB00400	PCB00410	PCB00420	PCB00425	PCB00430	PCB00435	PCB00440	

0000R

APPENDIX 3 (Continued)

REGISTER EQUATES

56	*		REGS - REGISTER EQUATES				
57	*						
58	*	PSWCCCL	EQU	X'FFFF0'			
59		PSWCCC	EQU	X'0008'	CONDITION CODE CLEAR		
60		PSWCCV	EQU	X'0004'	CARRY FLAG MASK		
61		PSWCCG	EQU	X'0002'	V FLAG MASK		
62		PSWCCCL	EQU	X'0001'	G FLAG MASK		
63	*	CRASH	EQU	0	L FLAG MASK		
64	*						
65							
66	*						
67	R0		EQU	0			
68	R1		EQU	1			
69	R2		EQU	2			
70	R3		EQU	3			
71	R4		EQU	4			
72	R5		EQU	5			
73	R6		EQU	6			
74	R7		EQU	7			
75	R8		EQU	8			
76	R9		EQU	9			
77	R10		EQU	10			
78	R11		EQU	11			
79	R12		EQU	12			
80	R13		EQU	13			
81	R14		EQU	14			
82	R15		EQU	15			
83	RA		EQU	10			
84	RB		EQU	11			
85	RC		EQU	12			
86	RD		EQU	13			
87	RE		EQU	14			
88	RF		EQU	15			
89	*	UTSTAT	EQU	X'7F00'	EI+MM+DF+AS+FP+OS+PM		
90		ETSTAT	EQU	X'7E00'	EI+MM+DF+AS+FP+OS		
91		SUSSTAT	EQU	X'7C00'	EI+MM+DF+AS+FP		
92		ISSSTAT	EQU	X'3000'	MM+DF		
93		WAITSTAT	EQU	X'FE00'	WT+EI+MM+DF+AS+FP+OS		
94		CRSTAT	EQU	X'A000'	WT+MM		
95							
97			COPY	SPT			

0000R

SYSTEM POINTER TABLE

APPENDIX 3 (Continued)

Address	Label	Value	Unit	Address	Label	Value	Unit
0000				PC800910			
000C				PC800920			
000E				PC800980			
0010				PC800940			
0012				PC800950			
0014				PC800960			
0016				PC800970			
001E				PC800980			
0020				PC800990			
0021				PC801000			
0022				PC801010			
0024				PC801020			
0026				PC801030			
0029				PC801040			
002C				PC801050			
003C				PC801060			
003E				PC801070			
0000R				PC801080			
				PC801090			
				PC801100			
				PC801110			
				PC801120			

Address	Label	Value	Unit	Address	Label	Value	Unit
99	*						
100	*						
101	*						
102	SPT	STRUC					
103	SPT.INIT	OS	12				
104	SPT.CRSH	DS	2				
105	SPT.CE	DS	2				
106	SPT.UBOT	DS	?				
107	SPT.FBOT	DS	2				
108	SPT.MTOP	DS	2				
109	SPT.OSID	DS	8				
110	SPT.TTAB	DS	2				
111	SPT.NTCB	DS	1				
112	SPT.CTCB	DS	1				
113	SPT.DMT	DS	2				
114	SPT.VMT	DS	2				
115	SPT.JRNL	DS	2				
116	SPT.FLPA	DS	4				
117	SPT.OVFD	DS	16				
118	SPT.SDCB	DS	2				
119	ADR.SPT	EQU	X'62				
120		ENDS					
122		COPY	TCB				

BRANCH TO SYSINIT
 CRASH CODE
 COMMAND ENTRY
 USER BOTTOM
 FCB RDTTOM
 MACHINE TOP
 NAME OF OS
 TCB TABLE
 # OF TCBS
 CURRENT TCB INDEX
 DMT ADDR
 VMT ADDR
 JOURNAL LIST ADDRESS
 FLBA OF OS OVERLAY FILE
 NAME OF OS OVERLAY FILE
 POINTER TO DCB OF OS OVERLAY DEVICE
 AIA(SPT))

TASK CONTROL BLOCK

APPENDIX 3 (Continued)

0000	124	*																					PCB01160
0008	125	*																					PCB01170
000A	126	*																					PCB01180
000E	127	*	TCB	TCB	TCB	TCB	STRUC																PCB01190
0012	128		TCR.ID	OS		8																	PCB01200
0014	129		TCB.STAT	DS		2																	PCB01210
0016	130		TCB.ITSM	OS		4																	PCB01220
0017	131		TCB.CPSK	OS		4																	PCB01230
0018	132		TCB.CTSM	OS		2																	PCB01240
0019	133		TCB.UBOT	DS		2																	PCB01250
002A	134		TCB.MPRI	DS		1																	PCB01260
0032	135		TCB.CPRI	OS		1																	PCB01270
0033	136		TCB.WTHR	DS		1																	PCB01280
0034	137		TCB.TVAL	DS		4																	PCB01290
0056	138		TCB.TVAL	DS		4																	PCB01300
	139		TCB.ADGT	DS		4																	PCB01310
	140		TCB.ADGP	DS		2																	PCB01320
	141		TCB.OPT	DS		2																	PCB01330
	142		TCB.FLGS	OS		2																	PCB01340
	143		TCB.WTAD	DS		2																	PCB01350
	144		TCB.MPT	DS		8																	PCB01360
	145		TCB.NLU	DS		1																	PCB01370
	146		TCB.PNT	DS		1																	PCB01380
	147		TCB.RC	DS		2																	PCB01390
	148		TCB.RSAY	DS		32																	PCB01400
	149		TCB.FMLU	DS		2																	PCB01410
	150		TCB.LTAB	EGU		*																	PCB01420
0056	151	*	TASK STATUS																				PCB01430
8000	152		TSTT.DMM	EGU		X'8000'																	PCB01440
4000	153		TSTT.IOM	EGU		X'4000'																	PCB01450
1000	154		TSTT.RWM	EGU		X'1000'																	PCB01460
0400	155		TSTT.CWM	EGU		X'0400'																	PCB01470
0200	156		TSTT.TIM	EGU		X'0200'																	PCB01480
0100	157		TSTT.TRM	EGU		X'0100'																	PCB01490
0080	158		TSTT.S2M	EGU		X'0080'																	PCB01500
0040	159		TSTT.S5M	EGU		X'0040'																	PCB01510
0020	160		TSTT.S7M	EGU		X'0020'																	PCB01520
0008	161		TSTT.DWM	EGU		X'0008'																	PCB01530
	162	*	TASK OPTIONS/FLAGS MASKS																				PCB01540
8000	163		TOPT.ETM	EGU		X'8000'																	PCB01550
4000	164		TOPT.ACH	EGU		X'4000'																	PCB01560
2000	165		TOPT.FPM	EGU		X'2000'																	PCB01570
1000	166		TOPT.WRM	EGU		X'1000'																	PCB01580
0800	167		TOPT.COM	EGU		X'0800'																	PCB01590
0400	168		TOPT.BGM	EGU		X'0400'																	PCB01595
0200	169		TOPT.S6M	EGU		X'0200'																	PCB01600
0040	170		TOPT.DFM	EGU		X'0040'																	PCB01605
0100	171		TOPT.ROM	EGU		X'0100'																	PCB01610
	172	*																					PCB01620
0080	173		TFLG.PPM	EGU		X'0080'																	PCB01630
0040	174		TFLG.CPM	EGU		X'0040'																	PCB01640
0020	175		TFLG.SLM	EGU		X'0020'																	PCB01650
0010	176		TFLG.BIM	EGU		X'0010'																	PCB01660
0008	177		TFLG.PRM	EGU		X'0008'																	PCB01670
0004	178		TFLG.RCM	EGU		X'0004'																	PCB01680
0002	179		TFLG.TOD	EGU		X'0002'																	PCB01690
0001	180		TFLG.TPM	EGU		X'0001'																	PCB01695

APPENDIX 3 (Continued)

TASK CONTROL BLOCK

```

0000
0800
0200
0100
0080
0040
0010
0040
0020
0010
0008
0004
0002
0001
0058
0000R

183 TTSW.PRM EQU X'4000'
184 TTSW.QSN EQU X'0800'
185 TTSW.DIM EQU X'0200'
186 TTSW.TCM EQU X'0100'
187 TTSW.TOM EQU X'0080'
188 TTSW.IPM EQU X'0040'
189 TTSW.PXM EQU X'0010'
190 * LU TABLE ATTRIBUTE BYTE
191 TLAT.RDM EQU X'40'
192 TLAT.WRM EQU X'20'
193 TLAT.BIM EQU X'10'
194 TLAT.WTM EQU X'08'
195 TLAT.RNM EQU X'04'
196 TLAT.UPM EQU X'02'
197 TLAT.IMM EQU X'01'
198

200 COPY DCB

```

```

POWER RESTORE TRAP ENABLE
QUEUE SERVICE TRAP ENABLE
QUEUE DEVICE INTERRUPT
QUEUE TASK CALL
QUEUE TIMEOUT
QUEUE I/O PROCEED COMPLETE
QUEUE SEND MESSAGE
READ
WRITE
BINARY
WAIT
RANDOM
UNCONDITIONAL PROCEED
IMAGE

```

EN006

```

PCB01720
PCB01730
PCB01740
PCB01750
PCB01760
PCB01770
PCB01775
PCB01780
PCB01790
PCB01800
PCB01810
PCB01820
PCB01830
PCB01840
PCB01850
PCB01860

```

APPENDIX 3 (Continued)

DEVICE CONTROL BLOCK

0000	0000	DCB,OPSM DS	4	OCB - DEVICE CONTROL BLOCK	LOGICAL RECORD LENGTH	PCB01900
0004	0004	DCB,NPSS DS	2		COUNTS	PCB01910
0006	0006	DCB,ENTR DS	10		WRITE COUNT	PCB01920
0010	0010	DCB,LEAV DS	4		READ COUNT	PCB01930
0014	0014	DCB,NOPI DS	4		DEVICE CODE	PCB01940
001C	001C	DCB,IOW EQU	**+1		DEVICE #	PCB01950
0038	0038	DCB,RSV DS	14*2		DEVICE ATTRIBUTES	PCB01960
003A	003A	DCB,ISR EQU	**+2		KEYS	PCB01970
003C	003C	DCB,EDDC EQU	*		WRITE KEY	PCB01980
003C	003C	DCB,SDN DS	1		READ KEY	PCB02000
003E	003E	DCB,CON DS	1		A(BUSY FLAG)	PCB02010
003E	003E	DCB,CLRT EQU	*		A(SELCH BUSY FLAG)	PCB02020
0040	0040	DCB,DBSY DS	2		A(TERMINATION ROUTINE)	PCB02030
0040	0040	DCB,BFSZ EQU	*		ABORT LOC	PCB02040
003E	003E	DCB,DPB EQU	*		TIME OUT COUNT	PCB02050
003E	003E	DCB,FCB EQU	**+2		FLAGS HALFWORD	PCB02060
003E	003E	DCB,FMEX DS	14		A(INITIALIZATION ROUTINE)	PCB02070
004E	004E	DCB,CSEC DS	4		OLD PSW SAVE AREA	PCB02080
0052	0052	DCB,DIRP DS	4		NEW PSW STATUS	PCB02100
0056	0056	DCB,BITP DS	4		INTERRUPT SERVICE ENTRY POINT	PCB02120
005C	005C	DCB,CCYL DS	2		INTERRUPT SERVICE EXIT LOCATION	PCB02130
0060	0060	DCB,FMFP DS	2		NOP ISR ENTRY	PCB02140
0061	0061	DCB,STRK DS	1		I/O WAIT POINTER	PCB02150
0062	0062	DCB,SIZE DS	4		SAVE AREA FOR REGISTERS 2-15	PCB02160
0066	0066	DCB,ASAV DS	16*2		RESERVED FOR BUSY FLAG	PCB02170
006A	006A	DCB,FSAV DS	4		BISYNC EXTENDED DEVICE CODE	PCB02180
008A	008A	DCB,FINX DS	2		SELCH DEVICE #	PCB02200
008C	008C	DCB,CBIT DS	4		A(CLOSE ROUTINE) FOR ITAM DRIVERS	PCB02220
0090	0090	DCB,BUFB DS	256		A(DISC BUSY FLAG)	PCB02230
01A6	01A6	DCB	EQU	**DCB,RECL	BISYNC BUFFER SIZE	PCB02240
8000	8000	DCB,BLM EQU	X'0000*	FLAGS MASKS	DUMMY PARAMETER BLOCK	PCB02250
0000	0000	DCB	EQU	VALUES	A(PCB) SAVE AREA	PCB02260
					A(FCB) SAVE AREA	PCB02270
					FILE MANAGER ALTERNATE EXIT	PCB02280
					CURRENT SECTOR POINTER	PCB02290
					FIRST DIRECTORY BLOCK POINTER-V.D.FOP	PCB02300
					BIT MAP POINTER-V.D.MAP	PCB02310
					CURRENT CYLINDER POINTER	PCB02320
					FILE MANAGER ENTRY POINT	PCB02330
					NUMBER OF SECTORS/CYLINDER	PCB02338
					OPTIMUM INCREMENT	PCB02336
					# OF SECTORS ON DEVICE	PCB02338
					ALTERNATE SAVE AREA	PCB02340
					FULLWORD SAVE AREA	PCB02350
					CURRENT INDEX INTO BIT MAP BUFFER	PCB02360
					CURRENT BIT MAP SECTOR POINTER	PCB02370
					BIT MAP SECTOR	PCB02380
					BULK DEVICE FLAG	PCB02390
					NON-LINE FLAG	PCB02410
						PCB02420
						PCB02430
						PCB02440
						PCB02450
						PCB02460
						PCB02470
						PCB02480
						PCB02490
						PCB02500
						PCB02510
						PCB02520
						PCB02530
						PCB02540
						PCB02550
						PCB02560
						PCB02570
						PCB02580
						PCB02590
						PCB02600

FILE CONTROL BLOCK

APPENDIX 3 (Continued)

0000	0002	0003	0004	0006	0008	000A	000E	000F	0010	0018	001B	001C	001E	0022	0026	002A	002B	002C	002E	0030	0031	0032	0040	004E	0050	0052	0054	0058	005C	0060	0062	0068	0080	0040	0020	0008	0004	0002	0001	0000	0002	0000	0004	0068											
312	313	314	315	316	317	318	319	320	321	322	323	324	325	326	327	328	329	330	331	332	333	334	335	336	337	338	339	340	341	342	343	344	345	346	347	348	349	350	351	352	353	354	355	356	357	358	359	360	361	362	363	364	365	366	367
*	*	*	*	*	*	*	*	*	*	*	*	*	*	*	*	*	*	*	*	*	*	*	*	*	*	*	*	*	*	*	*	*	*	*	*	*	*	*	*	*	*	*	*	*	*	*	*	*	*	*	*	*			
FCBI	FCB.VMT	FCB.CNTS	FCB.WCNT	FCB.RCNT	FCB.ATRB	FCB.LRCL	FCB.OFF	FCB.BKSZ	FCB.DIR	FCB.FLGS	FCB.DCOD	FCB.NAME	FCB.EXT	FCB.VERS	FCB.DCB	FCB.FLBA	FCB.LLBA	FCB.CSEC	FCB.LU	FCB.TPNT	FCB0	FCB.BLK	FCB.IBLK	FCB.INBS	FCB.CCR	FCB.BAPB	FCB.IBPB	FCB.NINB	FCB.CINX	FCB.NBLK	FCB.CBLK	FCB.CLRL	FCB.COFF	FCB.RSAV	FCB.BUFF	FLG.BAM	FLG.IUM	FLG.OPH	FLG.BMM	FLG.MOM	FLG.SBM	FLG.XMM	FDCD.CO	FDCD.IN	FINX.PRIV	FINX.NXT	ENDS								
STRUC	DS	DS	DS	DS	DS	DS	DS	DS	DS	DS	DS	DS	DS	DS	DS	DS	DS	DS	DS	EQU	DS	DS	DS	DS	DS	DS	DS	DS	DS	DS	DS	DS	DS	DS	EQU	EQU	EQU	EQU	EQU	EQU	EQU	EQU	EQU	EQU	EQU	EQU	EQU	EQU	EQU	EQU	EQU				
2	0	1	1	2	2	1	1	4	1	1	8	3	1	2	4	4	4	4	1	1	*	2	2	1	1	14	14	2	2	4	4	2	2	5*2	*	FLGS MASKS	X'00'	X'40'	X'20'	X'08'	X'04'	X'02'	X'01'	0	2	0	4	4							
ADDRESS OF VMT ENTRY	COUNTS	WRITE COUNT	READ COUNT	ATTRIBUTES OF FILE	LOGICAL RECORD LENGTH	DIRECTORY OFFSET	FILE BLOCK SIZE	ADDRESS OF DIRECTORY BLOCK	FLAGS	DEVICE CODE OF FILE 2=IN,0=C0	FILENAME	EXTENSION	VERSION	ADDRESS OF DCB	FIRST LOGICAL BLOCK ADDRESS	LAST LOGICAL BLOCK ADDRESS	CURRENT SECTOR/NLR	LOGICAL UNIT	TCB POINTER	LENGTH OF CONTIGUOUS FCB	ADDITIONAL FOR INDEXED FILES ONLY	BKSZ IN BYTES	INBS IN BYTES	INDEX BLOCK SIZE	CLEAR CHARACTER	DATA BLOCK PARAMETER BLOCK	INDEX BLOCK PARAMETER BLOCK	# OF INDEX BLOCKS	CURRENT INDEX BLOCK #	CURRENT OFFSET INTO INDEX BLOCK	# OF BLOCKS IN FILE	CURRENT BLOCK #	CURRENT LOGICAL RECORD #	CURRENT DATA BLOCK OFFSET	SAVE AREA FOR R15-R15	START OF INDEXED FILE BUFFER	FLGS MASKS	FCB IN USE FLAG	OPERATION SET IMPLIES WRITE	DATA MOD FLAG	MODESET IMPLIES EXTENDING FILE	BUSY FLAG SET FLAG	INDEX MOD FLAG	CONTIGUOUS FILE	INDEXED FILE	LINK TO PREVIOUS INDEX BLOCK	LINK TO NEXT INDEX BLOCK	ENDS							
PCB02950	PCB02940	PCB02980	PCB02960	PCB02970	PCB02990	PCB03000	PCB03010	PCB03020	PCB03030	PCB03050	PCB03060	PCB03070	PCB03080	PCB03090	PCB03100	PCB03110	PCB03120	PCB03130	PCB03140	PCB03150	PCB03160	PCB03170	PCB03180	PCB03190	PCB03200	PCB03210	PCB03220	PCB03230	PCB03240	PCB03250	PCB03260	PCB03270	PCB03280	PCB03290	PCB03300	PCB03310	PCB03320	PCB03330	PCB03340	PCB03350	PCB03360	PCB03370	PCB03380	PCB03390	PCB03400	PCB03410	PCB03420	PCB03430	PCB03440	PCB03450	PCB03460	PCB03470	PCB03480		

SVC1 PARAMETER BLOCK

APPENDIX 3 (Continued)

371	4	SVC1	SVC1	SVC1	PARAMETER BLOCK	PCB03590
372	*	SVC1	SVC1	SVC1	FUNCTION CODE	PCB03591
373		SVC1	SVC1	SVC1	LOGICAL UNIT	PCB03592
374		SVC1	SVC1	SVC1	STATUS	PCB03593
375		SVC1	SVC1	SVC1	DEVICE IDENTIFICATION SYSTEM	PCB03594
376		SVC1	SVC1	SVC1	STARTING ADDRESS	PCB03595
377		SVC1	SVC1	SVC1	ENDING ADDRESS	PCB03596
378		SVC1	SVC1	SVC1	LENGTH OF LAST TRANSFER	PCB03597
379		SVC1	SVC1	SVC1	FUNCTION CODE	PCB03598
380		SVC1	SVC1	SVC1	FUNCTION CODE	PCB03599
381		SVC1	SVC1	SVC1	FUNCTION CODE	PCB03600
382		SVC1	SVC1	SVC1	FUNCTION CODE	PCB03601
383		SVC1	SVC1	SVC1	FUNCTION CODE	PCB03602
384		SVC1	SVC1	SVC1	FUNCTION CODE	PCB03603
385		SVC1	SVC1	SVC1	FUNCTION CODE	PCB03604
386		SVC1	SVC1	SVC1	FUNCTION CODE	PCB03605
387		SVC1	SVC1	SVC1	FUNCTION CODE	PCB03606
388		SVC1	SVC1	SVC1	FUNCTION CODE	PCB03607
389		SVC1	SVC1	SVC1	FUNCTION CODE	PCB03608
390		SVC1	SVC1	SVC1	FUNCTION CODE	PCB03609
391		SVC1	SVC1	SVC1	FUNCTION CODE	PCB03610
392		SVC1	SVC1	SVC1	FUNCTION CODE	PCB03611
393		SVC1	SVC1	SVC1	FUNCTION CODE	PCB03612
394		SVC1	SVC1	SVC1	FUNCTION CODE	PCB03613
395		SVC1	SVC1	SVC1	FUNCTION CODE	PCB03614
396		SVC1	SVC1	SVC1	FUNCTION CODE	PCB03615
397		SVC1	SVC1	SVC1	FUNCTION CODE	PCB03616
398		SVC1	SVC1	SVC1	FUNCTION CODE	PCB03617
399		SVC1	SVC1	SVC1	FUNCTION CODE	PCB03618
400	*	SVC1	SVC1	SVC1	STATUS HALFWORD	PCB03619
401		SVC1	SVC1	SVC1	STATUS HALFWORD	PCB03620
402		SVC1	SVC1	SVC1	STATUS HALFWORD	PCB03621
403		SVC1	SVC1	SVC1	STATUS HALFWORD	PCB03622
404		SVC1	SVC1	SVC1	STATUS HALFWORD	PCB03623
405		SVC1	SVC1	SVC1	STATUS HALFWORD	PCB03624
406		SVC1	SVC1	SVC1	STATUS HALFWORD	PCB03625
407		SVC1	SVC1	SVC1	STATUS HALFWORD	PCB03626
408		SVC1	SVC1	SVC1	STATUS HALFWORD	PCB03627
409		SVC1	SVC1	SVC1	STATUS HALFWORD	PCB03628
411		SVC1	SVC1	SVC1	COPY	PCB03629
					ENDS	PCB03630
					ENDS	PCB03631
					ENDS	PCB03632
					ENDS	PCB03633
					ENDS	PCB03634
					ENDS	PCB03635
					ENDS	PCB03636
					ENDS	PCB03637
					ENDS	PCB03638
					ENDS	PCB03639
					ENDS	PCB03640
					ENDS	PCB03641
					ENDS	PCB03642
					ENDS	PCB03643
					ENDS	PCB03644
					ENDS	PCB03645
					ENDS	PCB03646
					ENDS	PCB03647
					ENDS	PCB03648
					ENDS	PCB03649
					ENDS	PCB03650
					ENDS	PCB03651
					ENDS	PCB03652
					ENDS	PCB03653
					ENDS	PCB03654
					ENDS	PCB03655
					ENDS	PCB03656
					ENDS	PCB03657
					ENDS	PCB03658
					ENDS	PCB03659
					ENDS	PCB03660
					ENDS	PCB03661
					ENDS	PCB03662
					ENDS	PCB03663
					ENDS	PCB03664
					ENDS	PCB03665
					ENDS	PCB03666
					ENDS	PCB03667
					ENDS	PCB03668
					ENDS	PCB03669
					ENDS	PCB03670
					ENDS	PCB03671
					ENDS	PCB03672
					ENDS	PCB03673
					ENDS	PCB03674
					ENDS	PCB03675
					ENDS	PCB03676
					ENDS	PCB03677
					ENDS	PCB03678
					ENDS	PCB03679
					ENDS	PCB03680
					ENDS	PCB03681
					ENDS	PCB03682
					ENDS	PCB03683
					ENDS	PCB03684
					ENDS	PCB03685
					ENDS	PCB03686
					ENDS	PCB03687
					ENDS	PCB03688
					ENDS	PCB03689
					ENDS	PCB03690

SVC6 PARAMETER BLOCK

```

0000
0008
0008
000A
000C
000F
0010
0011
0012
0013
0014
0016
0016
0017
001A
001E
0020
0022
0026
0000R

428 *
429 *
430 *
431 SVC6, STRUC
432 SVC6,IO DS
433 SVC6,FUN DS
434 SVC6,FC1 DS
435 SVC6,FC2 DS
+36 SVC6,TST DS
437 SVC6,STA DS
438 SVC6,LU DS
439 SVC6,PRI DS
440 SVC6,PRPI DS
441
442 SVC6,SAD DS
443 SVC6,TIM DS
444 SVC6,TTM DS
445 SVC6,DTM DS
446 SVC6,DMN DS
447 SVC6,PAR DS
448 SVC6,MSG DS
449
450 SFC1,DOM EQU
451 SFC1,DSM EQU
452 SFC1,EDM EQU
453 SFC1,ECP EQU
454 SFC1,LM EQU
455 SFC1,PKM EQU
456 SFC1,MM EQU
457 SFC1,OM EQU
458 SFC1,PM EQU
459 SFC2,OM EQU
460 SFC2,TM EQU
461 SFC2,IM EQU
462 SFC2,FM EQU
463 SFC2,UM EQU
464 SFC2,UFM EQU
465 SFC2,SDM EQU
466 SFC2,SIM EQU
467
469 COPY SVC7,
ENDS

```

```

PCB04060
PCB04090
PCB04100
PCB04110
PCB04120
PCB04130
PCB04140
PCB04150
PCB04160
PCB04170
PCB04180
PCB04190
PCB04200
PCB04210
PCB04220
PCB04230
PCB04240
PCB04250
PCB04260
PCB04270
PCB04275
PCB04280
PCB04290
PCB04300
PCB04310
PCB04320
PCB04330
PCB04340
PCB04345
PCB04350
PCB04360
PCB04370
PCB04380
PCB04390
PCB04400
PCB04410
PCB04420
PCB04430
PCB04440
PCB04450

```

```

TASK ID
FUNCTION, COMP
PART 1
PART 2
TASK STATUS
ERROR POINTER AND CODE
LOAD LU
PRIORITY
RETURN PRIORITY
RESERVED
START ADDRESS
TIME VALUES:
TYPE TIME
DELAY TIME
DEVICE MNEMONIC
PARAMETER
A(MESSAGE)
RESERVED
DIRECTION: OTHER TASKS
DIRECTION: SELF
END TASK: DELETE
END TASK: CANCEL
LOAD TASK
FIX (MAKE RESIDENT)
SEND MESSAGE
QUEUE PARAMETER
CHANGE PRIORITY
CONNECT DEVICE TO SPECIFIED TASK
THAW (ENABLE INTERRUPTS)
SINT (SIMULATE INTERRUPT)
FREEZE (DISABLE INTERRUPTS)
UNCONNECT DEVICE
UNFIX (MAKE NON-RESIDENT)
DELAY START
START IMMEDIATELY

```

```

-4 BYTES
-4 BYTES
END06
END06
END06

```

APPENDIX 3 (Continued)

SVC7 PARAMETER BLOCK

PCB#	Address	Hex	Label	Value	Option/Modifier	PCB#
PCB04490	471	*	SVC7. - SVC7 PARAMETER BLOCK			
PCB04500	472	*				
PCB04510	473	*				
PCB04520	474	SVC7.	STRUC	0		
PCB04530	475	SVC7.OPT	DS	1		
PCB04540	476	SVC7.CMD	DS	1		
PCB04550	477	SVC7.MOD	DS	1		
PCB04560	478	SVC7.STA	DS	1		
PCB04570	479	SVC7.LU	DS	1		
PCB04580	480	SVC7.KYS	DS	0		
PCB04590	481	SVC7.WKY	DS	1		
PCB04600	482	SVC7.RKY	DS	1		
PCB04610	483	SVC7.LRC	DS	2		
PCB04620	484	SVC7.VOL	DS	4		
PCB04630	485	SVC7.FNM	DS	8		
PCB04640	486	SVC7.EXT	DS	3		
PCB04650	487	SVC7.VER	DS	1		
PCB04660	488	SVC7.SIZ	DS	0		
PCB04670	489	SVC7.ISZ	DS	2		
PCB04680	490	SVC7.DSZ	DS	2		
PCB04690	491	*	COMMAND	X'8000'	ALLOCATE	
PCB04700	492	S7CM.ALM	ERU	X'4000'	ASSIGN	
PCB04710	493	S7CP.ASM	EGU	X'2000'	CHANGE ACCESS PRIVILEGES	
PCB04720	494	S7CM.CAM	EGU	X'1000'	RENAME	
PCB04730	495	S7CM.RNM	EGU	X'0800'	REPROTECT	
PCB04740	496	S7CM.RPM	EGU	X'0400'	CLOSE	
PCB04750	497	S7CM.CLM	EGU	X'0200'	DELETE	
PCB04760	498	S7CM.DEM	EGU	X'0100'	CHECKPOINT	
PCB04770	499	S7CM.CPM	EGU	X'0000'	FETCH ATTRIBUTES	
PCB04780	500	S7CM.FEM	EGU	X'0000'		
PCB04790	501	*	MODIFIER BYTE			
PCB04800	502	S7M.SRU	ERU	X'20'		
PCB04810	503	S7M.ERO	ERU	X'40'		
PCB04820	504	S7M.SWO	ERU	X'60'		
PCB04830	505	S7M.EWO	ERU	X'80'		
PCB04840	506	S7M.SRW	ERU	X'A0'		
PCB04850	507	S7M.SREW	ERU	X'CO'		
PCB04860	508	S7M.ERSW	ERU	X'E0'		
PCB04870	509	S7M.ERW	ERU			
PCB04880	510	*	BUFFER MANAGEMENT			
PCB04890	511	S7M.DFT	ERU	X'00'	DEFAULT BUFFER MANAGEMENT	
PCB04900	512	S7M.UHUF	ERU	X'08'	UNBUFFERED PHYSICAL	
PCB04910	513	S7M.BUF	ERU	X'10'	BUFFERED LOGICAL	
PCB04920	514	*	FILE TYPES			
PCB04930	515	S7M.CO	ERU	X'00'	CONTIGUOUS FILE	
PCB04940	516	S7M.IN	ERU	X'02'	INDEXED FILE	
PCB04950	517		ENDS			
	519		COPY	VD		
		0000				
		0001				
		0002				
		0003				
		0004				
		0005				
		0006				
		0008				
		000C				
		0014				
		0017				
		0018				
		001A				
		001C				
		0000R				

PC804990
 PC805000
 PC805010
 PC805020
 PC805030
 PC805040
 PC805050
 PC805060
 PC805070
 PC805080
 PC805090
 PC805095

457D

VOLUME NAME
 VOLUME ATTRIBUTES
 FIRST DIRECTORY BLOCK POINTER
 OS IMAGE POINTER
 OS IMAGE SIZE (IN SECTORS)
 BIT MAP POINTER
 DISC IS MARKED ON

VD - VOLUME DESCRIPTOR

521 * VD STRUC 4
 522 * VD.VOL OS 4
 523 * VD.ATTR OS 4
 524 * VD.FDP OS 4
 525 * VD.OSP OS 4
 526 * VD.OSS OS 4
 527 * VD.MAP OS 4
 528 * VTR.ONM EQU X'8000'
 529 * COPY DIR
 530 *
 531 *
 532 *
 533 *
 534 *

0000
 0004
 0008
 000C
 0010
 0014
 0018

0000R