

WANG

3106

**CONTROL DATA CORPORATION
REMOVABLE STORAGE DRIVE
DIAGRAMS**

Models:

**PA3A1
PA3A2**

Volume 3

**Customer Engineering Reprint
Product Maintenance Manual**

741-1489

PREFACE

The purpose of this manual is to provide the Wang-trained Customer Engineer (CE) with instructions to operate, troubleshoot, and repair the Removable Storage Drive.

First Edition (June, 1984)

This is the first reprint of Control Data Corporation's RSD, Volume 3. The material in this document may only be used for the purpose stated in the Preface. Updates and/or changes to this document will be published as Product Update Bulletins (PUB's) or subsequent editions.

This document is the property of Wang Laboratories, Inc. All information contained herein is considered company property, and its use is restricted solely for the purpose of assisting the Wang-trained CE in servicing this Wang product. Reproduction of all or any part of this document is prohibited without prior consent of Wang Laboratories, Inc.



CDC® REMOVABLE STORAGE DRIVE

PA3A1

PA3A2

DIAGRAMS

Volume 3

HARDWARE MAINTENANCE MANUAL

REVISION RECORD

REVISION	DESCRIPTION
01 (11-18-82)	Preliminary Release
A (12-22-82)	Manual released documenting series codes 01 and 02 units. This edition obsoletes all previous editions.
B (05-03-83)	Manual revised to incorporate the following series code 03 and 04 changes: ECO's 03253, 03282, technical changes, editorial changes, and to add dual channel (PA3A2) documentation to manual. This edition obsoletes all previous editions.
C (07-08-83)	Manual revised to incorporate series code 05 and technical and editorial changes.
D (09-28-83)	Manual revised to incorporate the following series code 06 changes: ECO's 03322, 03392, 03308, 03463, technical changes, and editorial changes.
E (12-05-83)	Manual revised to incorporate the following series code 07 changes: ECO 03436, technical changes and editorial changes.

REVISION LETTERS I, O, Q
AND X ARE NOT USED.

Address comments concerning this
manual to:

Control Data Corporation
Small Disk Division
Customer Documentation Dept.
7725 Washington Avenue So.
Edina, Mn 55435

© 1982, 1983
By Control Data Corporation
Printed in the United States
of America

or use Comment Sheet in the back
of this manual.

LIST OF EFFECTIVE PAGES

Sheet 1 of 4

New features, as well as changes, deletions, and additions to information in this manual are indicated by bars in the margins or by a dot near the page number if the entire page is affected. A bar by the page number indicates pagination rather than content has changed.

<u>PAGE</u>	<u>REV</u>	<u>PAGE</u>	<u>REV</u>
Cover	-	1-15	B
Blank	-	1-16	A
Title P	-	1-17	C
ii	E	1-18	A
iii	E	1-19	B
iv	E	Blank	-
v	E	1-21	B
vi	D	1-22	B
vii	B	1-23	B
viii	B	1-24	A
ix	B	1-25	C
Blank	-	1-26	B
xi	B	1-27	E
xii	B	Blank	-
xiii	B	1-29	B
xiv	B	1-30	B
S-1 Div	-	1-30.1	E
Blank	-	1-30.2	B
1-1	A	1-30.3	B
1-2	A	Blank	-
1-3	A	1-30.5	B
1-4	A	1-30.6	B
1-5	C	1-30.7	B
1-6	A	1-30.8	B
1-7	A	1-30.9	C
1-8	A	1-30.10	D
1-9	D	1-30.11	D
Blank	-	1-30.12	D
1-10.1	D	1-30.13	E
1-10.2	B	Blank	-
1-11	A	1-30.15	D
1-12	B	1-30.16	D
1-13	B	1-31	B
Blank	-	1-32	B

LIST OF EFFECTIVE PAGES (Contd)

Sheet 2 of 4

<u>PAGE</u>	<u>REV</u>	<u>PAGE</u>	<u>REV</u>
1-33	B	1-72	B
Blank	-	1-73	C
1-35	B	1-74	B
1-36	B	1-75	B
1-37	B	1-76	B
1-38	B	1-77	D
1-39	D	1-78	B
Blank	-	1-79	D
1-41	B	1-80	B
Blank	-	1-81	B
1-43	B	Blank	-
Blank	-	1-83	B
1-45	B	Blank	-
Blank	-	1-85	B
1-47	B	1-86	B
1-48	B	1-87	D
1-49	E	Blank	-
1-50	B	1-89	D
1-51	B	Blank	-
1-52	B	1-91	B
1-53	B	1-92	B
1-54	B	1-93	C
1-55	B	1-94	B
1-56	D	1-95	C
1-57	D	Blank	-
1-58	D	1-97	B
1-59	D	1-98	B
1-60	B	1-99	C
1-61	E	1-100	B
1-62	B	1-101	D
1-63	B	1-102	B
1-64	B	1-103	B
1-65	B	Blank	-
1-66	D	1-105	D
1-67	D	1-106	D
1-68	B	1-106.1	D
1-69	B	1-106.2	D
1-70	B	1-106.3	D
1-71	C	1-106.4	D

LIST OF EFFECTIVE PAGES (Contd)

Sheet 3 of 4

<u>PAGE</u>	<u>REV</u>	<u>PAGE</u>	<u>REV</u>
1-106.5	D	Blank	-
1-106.6	D	1-106.45	D
1-106.7	D	1-106.46	D
1-106.8	D	1-107	B
1-106.9	D	1-108	B
1-106.10	D	1-109	B
1-106.11	D	Blank	-
1-106.12	D	1-111	B
1-106.13	D	1-112	B
1-106.14	D	1-113	C
1-106.15	D	1-114	B
1-106.16	D	1-115	C
1-106.17	D	1-116	B
1-106.18	D	1-117	B
1-106.19	D	1-118	B
1-106.20	D	1-119	B
1-106.21	D	Blank	-
Blank	-	1-121	B
1-106.23	D	1-122	B
Blank	-	1-123	E
1-106.25	D	1-124	B
1-106.26	D	1-125	E
1-106.27	D	1-126	B
Blank	-	1-127	C
1-106.29	D	1-128	C
Blank	-	1-128.1	C
1-106.31	D	1-128.2	C
1-106.32	D	1-129	B
1-106.33	D	1-130	B
1-106.34	D	1-131	B
1-106.35	D	Blank	-
Blank	-	1-133	B
1-106.37	D	1-134	B
1-106.38	D	1-135	D
1-106.39	D	1-136	B
1-106.40	D	1-137	B
1-106.41	D	1-138	B
1-106.42	D	1-139	B
1-106.43	D	Blank	-

LIST OF EFFECTIVE PAGES (Contd)

Sheet 4 of 4

<u>PAGE</u>	<u>REV</u>	<u>PAGE</u>	<u>REV</u>
1-141	B	1-154	D
1-142	B	1-155	B
1-143	D	1-156	B
Blank	-	1-157	B
1-145	B	1-158	B
1-146	B	1-159	B
1-147	B	1-160	B
1-148	B	1-161	B
1-149	B	Blank	-
1-150	B	Cmt Sht	-
1-151	B	Rtn Env	-
1-152	B	Blank	-
1-153	B	Cover	-

PREFACE

This manual contains maintenance information for the CONTROL DATA® PA3A1/PA3A2 Removable Storage Drive (RSD). It is prepared for customer engineers and other technical personnel directly involved with maintaining the RSD.

The information in this manual is presented as follows:

Section 1 - Diagrams. Contains logic diagrams.

The following manuals apply to the RSD and are available from Control Data Corporation, Literature Distribution Services, 308 North Dale Street, St. Paul, MN 55103:

<u>Publication No.</u>	<u>Title</u>
83324480	PA3A1/PA3A2 Hardware Maintenance Manual, Volume 1 (contains general description, operation, installation and checkout information, and parts data)
83324490	PA3A1/PA3A2 Hardware Maintenance Manual, Volume 2 (contains theory of operation and maintenance)
83324630	PA3A1/PA3A2 Hardware Maintenance Manual, Volume 3 (contains diagrams)
83322440	CDC Microcircuits, Volume 1 (provides functional descriptions for integrated circuits)
83324440	CDC Microcircuits, Volume 2 (provides functional descriptions for integrated circuits)

WARNING

To ensure the integrity of safety features built into these drives, installation and maintenance must be performed only by qualified service personnel using designated CDC/MPI parts. Also, in case of fire or other emergency, isolate the drives from main power by disconnecting the drive power plugs from their site power receptacles. In situations where pulling the plugs is not possible or practical, use the system main power disconnect to isolate the drives from main power.

WARNUNG

Um das einwandfreie Funktionieren der eingebauten Schutzvorrichtungen zu gewährleisten, darf die Installation und Wartung nur von qualifiziertem Service-Personal unter Verwendung von Original CDC/MPI Teilen durchgeführt werden. Beim Ausbrechen von Feuer oder in anderen Notfällen ist die Verbindung zum Hauptstromnetz dadurch zu unterbrechen, dass die Stecker der Antriebe aus den Steckdosen gezogen werden. Sollte dies nicht möglich oder unpraktisch sein, ist der Hauptstromunterbrecher des Systems zu bedienen, um die Antriebe vom Hauptstromnetz zu trennen.

CONTENTS

Abbreviations	xi
1. DIAGRAMS	
Introduction	1-1
Symbology	1-1
General	1-1
Qualifying (Function) Symbol	1-2
Element Identifier	1-2
Location Code	1-2
Abbreviations	1-2
Logic Levels	1-2
Signal Names	1-4
Logic Arrangement	1-4
Logic Diagram Cover Sheets	1-6
Card Type	1-6
Intersheet References	1-7

FIGURES

1-1	Logic Symbology	1-1
1-2	Location Code Example	1-3
1-3	Circuit Board Locations	1-6
1-4	Key to Logic	1-8

TABLES

1-1	Logic Voltage Levels	1-4
1-2	Contents of Diagrams	1-5

ABBREVIATIONS

A	Ampere	CLK	Clock
ABV	Above	CLR	Clear
ac	Alternating Current	cm	Centimeter
ADD	Address	CNTR	Counter
ADDR	Address	COMP	Comparator
ADJ	Adjust	CONT	Control
ADRS	Address	CONTD	Continued
AGC	Automatic Gain Control	CT	Center Tap
ALT	Alternate	CYL	Cylinder
AM	Address Mark	D/A	Digital to Analog
AME	Address Mark Enable	DC	Direct Current
AMP	Amplifier, Ampere	DET	Detect
ASSY	Assembly	DIFF	Differential
BLW	Below	DIV	Division
C	Celsius	DLY	Delay
CB	Circuit Breaker	DRVR	Driver
CDA	Complete Drive Assembly	ECL	Emitter Coupled Logic
CDC	Control Data Corporation	ECO	Engineering Change Order
CH	Channel	EN	Enable
CHK	Check	ENBL	Enable

ABBREVIATIONS (Contd)

EXT	External	IND	Index
F	Fahrenheit, Fuse	INTRPT	Interrupt
FCO	Field Change Order	I/O	Input/Output
FDBK	Feedback	IPB	Illustrated Parts Breakdown
FIG	Figure	IPS	Inches per Second
FLT	Fault	kg	Kilogram
FSD	Fixed Storage Drive	kPa	Kilopascal
ft	Foot	kW	Kilowatt
FTU	Field Test Unit	lb	Pound
FWD	Forward	LED	Light Emitting Diode
GND	Ground	LSI	Large Scale Integration
HD	Head	LTD	Lock to Data
HEX	Hexagon	m	Meter
Hg	Mercury	MAX	Maximum
HR	High Resolution	MB	Megabyte
HYST	Hysteresis	MEM	Memory
Hz	Hertz	MHz	Megahertz
IC	Integrated Circuit	mm	Millimeter
IDENT	Identification	MPI	Magnetic Peripherals, Inc.
in	Inch		

ABBREVIATIONS (Contd)

MPU	Microprocessor Unit	PS	Power Supply
MRK	Mark	PWR	Power Supply
ms	Millisecond	RCVR	Receiver
MTR	Motor	RD	Read
mV	Millivolt	RDY	Ready
NC	No Connection	REF	Reference
NORM	Normal	REQ	Request
NRZ	Non Return to Zero	RES	Resolution
ns	Nanosecond	REV	Reverse, Revision
OC	On Cylinder	RGTR	Register
OS	One-Shot	r/min	Revolutions Per Minute
OSC	Oscillator	RSD	Removable Storage Drive
P	Plug	RTZ	Return to Zero
PD	Peak Detect	R/W	Read/Write
pF	Picofarad	s	Second
PG	Page	S/C	Series Code
PHH	Phillips Head	SEC	Second
PLO	Phase Lock Oscillator	SEL	Select
PROC	Procedure	SEQ	Sequence
PROG	Programmable	SPD	Speed

ABBREVIATIONS (Contd)

SS	Sector Switch	W	Watts
T	Tracks to go	W/	With
TP	Thread Forming	W/O	Without
TIM	Timer	W PROT	Write Protect
TP	Test Point	W+R	Write or Read
TSP	Troubleshooting Procedure	W·R	Write and Read
TTL	Transistor-Transistor Logic	WRT	Write
V	Volts, Voltage	XFR	Transfer
Vbb	Bias Voltage	Ω	Ohms
VCC	Bias Voltage	\$	Hexadecimal Address
VCO	Voltage Controlled Oscillator	uF	Microfarad
		us	Microsecond

SECTION

1

DIAGRAMS

INTRODUCTION

This section contains the logic diagrams and an explanation of the diagram conventions. The diagram conventions, along with the microcircuit manuals, provide the necessary information to understand and use the diagrams. The diagram conventions are:

- Symbology
- Abbreviations
- Logic Levels
- Signal Names
- Logic Arrangement
- Intersheet References

SYMBOLGY

GENERAL

The diagrams contain a modified version of ANSI standard Y32.14 logic symbology (see figure 1-1). The logic symbols for integrated circuits contain a qualifying symbol, an element identifier, and a location code.

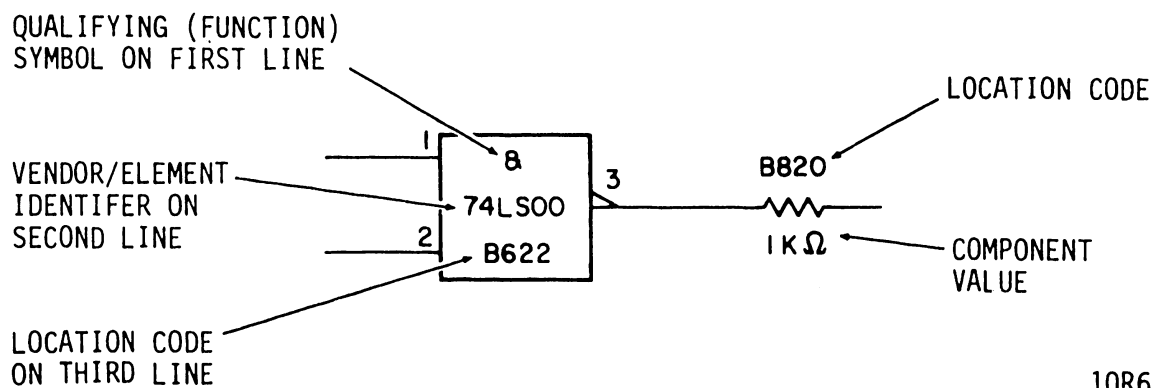

Figure 1-1. Logic Symbology

QUALIFYING (FUNCTION) SYMBOL

The qualifying symbol denotes the basic operation being performed by the integrated circuit. Refer to the microcircuits manual for an explanation of the qualifying symbols used in the diagrams.

ELEMENT IDENTIFIER

The second line of any symbol contains the vendor/element identifier. This number identifies the integrated circuit type. Refer to the microcircuits manuals for an explanation of the element identifiers used in the diagrams.

LOCATION CODE

The location code identifies the location of each component on the circuit board. The location code is a four-character XXYY designation related to an X-Y grid defined on the edges of the circuit board. To avoid confusion, the "XX" characters are alpha-numeric and the "YY" characters are numeric. Figure 1-2 shows a circuit board with a component at location code B622, which is the intersection of grid lines B6 (X) and 22 (Y).

ABBREVIATIONS

Standard abbreviations from ANSI Y1.1 are used whenever possible. Refer to the list of abbreviations contained in the front matter for a definition of all abbreviations used in the diagrams.

LOGIC LEVELS

Three types of logic are used in the drives that this manual applies to: TTL logic, ECL logic, and CMOS logic. Logic levels for the three types are shown in table 1-1. Different circuit configurations and temperatures may result in legitimate readings that fall outside of the typical range. Such readings should be suspect only in the event of problems.

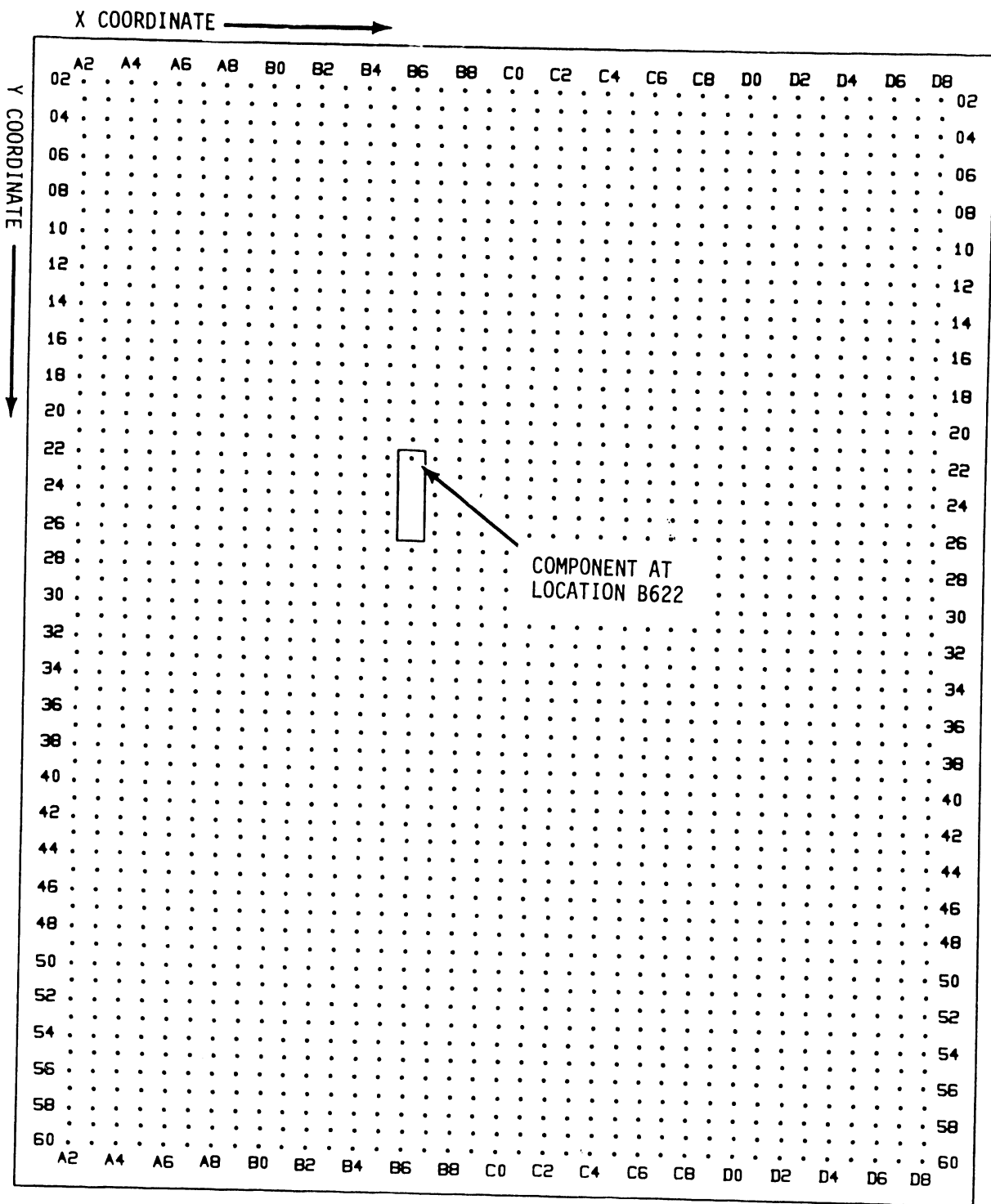

10R67

Figure 1-2. Location Code Example

TABLE 1-1. LOGIC VOLTAGE LEVELS

Logical State	Nominal Voltage	Typical Range
TTL "1"	3.3 V	2.0 V to 3.3 V*
TTL "0"	0.2 V	0.2 V to 0.8 V
ECL "1"	-0.924 V	-0.96 V to -0.81 V
ECL "0"	-1.75 V	-1.65 V to -1.85 V
CMOS "1"	5.0 V	3.5 V to 5.0 V
CMOS "0"	0 V	0 V to 1.5 V

*Measuring a TTL open collector voltage may result in a reading that is close to the actual power supply voltage.

SIGNAL NAMES

Input and output signals are labeled to reflect their particular function. If an output signal has no connection, and therefore no function, it is labelled "NC" to indicate no connection. The polarity (logical state) of a signal is identified by a plus or minus sign before the signal name. A plus sign before a signal name indicates that the signal is active when the logic level is high or in a logical "1" state. A minus sign before a signal name indicates that the signal is active when the logic level is low or in a logical "0" state. Refer to the discussion on logic levels.

LOGIC ARRANGEMENT

Logic diagrams for the drive consist of overall block diagrams and independent diagram sets for the interlocks, the detachable cables, and the circuit boards. The diagram sets are presented in the order given in table 1-2. Refer to figure 1-3 for the location of the circuit boards in the drive.

Each diagram set consists of one or more sheets with each sheet identified by the sheet number which appears in the lower right-hand corner of the page. The first sheet in each set, the cover sheet, is described in the following paragraph.

TABLE 1-2. CONTENTS OF DIAGRAMS

Card Type	Cross Ref. Number	Title
	0002	24" RSD Block Diagram
_PBX	01XX	Operator Panel
_EBN	02XX	Single Channel I/O
_UUN	03XX	Servo Preamp
_PEX	04XX	Control Board
_PDX	05XX	Power Amp
_PMX	06XX	Motor Speed Control
_PGX	07XX	Read/Write PLOs
_PFX	08XX	Data Latch
_PCX	09XX	R/W Preamp
	1002	DC Harness Cabling Diagram
	1012	Control Board to I/O Board Cable
	1022	Control Board to Data Latch & R/W PLOs Cable
	1032	Motor Speed Control to Motor Cable
	1042	Interlocks
	1052	Servo Preamp to R/W Preamp
	1062	Data Latch to R/W Preamp

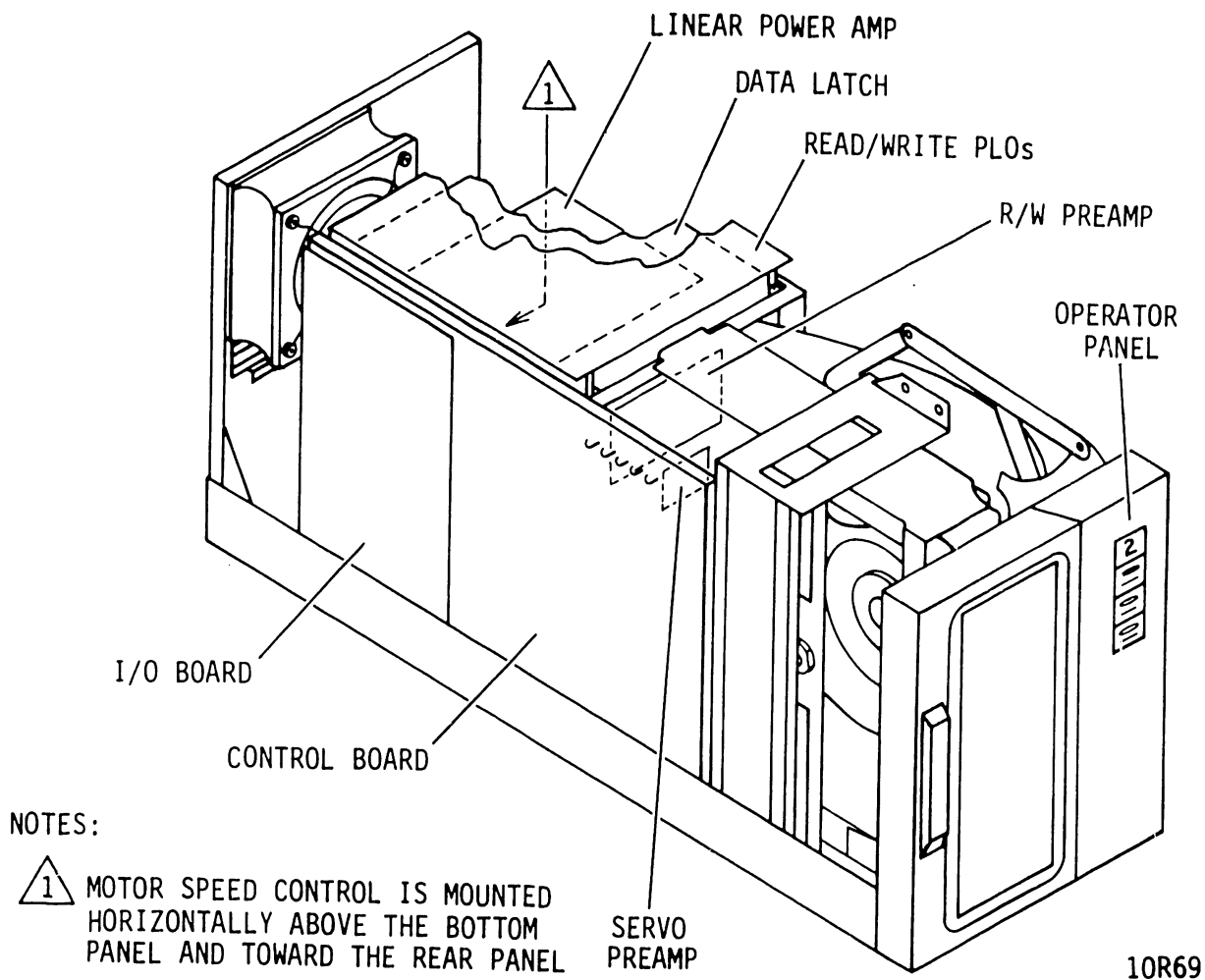

Figure 1-3. Circuit Board Locations

LOGIC DIAGRAM COVER SHEETS

The logic diagram cover sheet is the first sheet of each logic set. It contains power and ground connections, and lists unused logic elements. In the larger logic sets, either sheet 1 or sheet 2 has a table that cross-references each connector pin number to the logic sheet showing that signal input or output.

CARD TYPE

The card type designation is shown on sheet 1 in the title block.

INTERSHEET REFERENCES

Each logic diagram is assigned a four-digit cross-reference number and a two-digit sheet number. The first two digits of the cross-reference number indicate the assigned set number, and the last two digits indicate the sheet number within that set. Table 1-2 lists the cross-reference number for each logic diagram set. The following paragraphs discuss how to trace signals from one point to another in the diagrams and refer to both the sheet numbers and the cross-reference numbers.

The procedure for tracing signals in the logic diagrams depends on whether the signal path continues on the same sheet, on another sheet in the same logic set, or on a sheet in a different logic set. These three cases are symbolized differently in the logic (see figure 1-4) and are discussed separately in the following paragraphs.

When a logic signal is continued on the same sheet but cannot be shown in series, "line of sight" arrows along with a letter within a circle are used to indicate signal origin and destination.

When a logic signal is continued on another sheet of the same logic set, that sheet number appears next to a hexagon containing a designating letter. This same letter is then shown where the signal is continued.

When a signal is continued on a sheet of another logic set, it follows a path through a cable from one circuit board to another. Each sheet of logic which has signals coming from or going to other circuit boards is accompanied by a Logic Cross Reference Information sheet, printed on the page facing the logic sheet. Logic Cross Reference Information lists all signal inputs and signal outputs in the order they appear on the logic sheet. Each signal input listing includes the cross-reference number of the logic sheet where the signal originates and the connector and pin number for the signal origin. Each signal output listing includes the crossreference number of the logic sheet where the signal goes and the connector and pin number for the signal destination.

Each logic sheet is linked to its associated Logic Cross Reference Information sheet by the connector and pin symbols that are duplicated on both sheets. For instance, if a logic sheet shows a signal entering the board on pin 1 of connector J14, then the Logic Cross Reference Information sheet has the following entry under Signal Inputs:

```
01    J14  
----->>----- |
```

Figure 1-4. Key to Logic

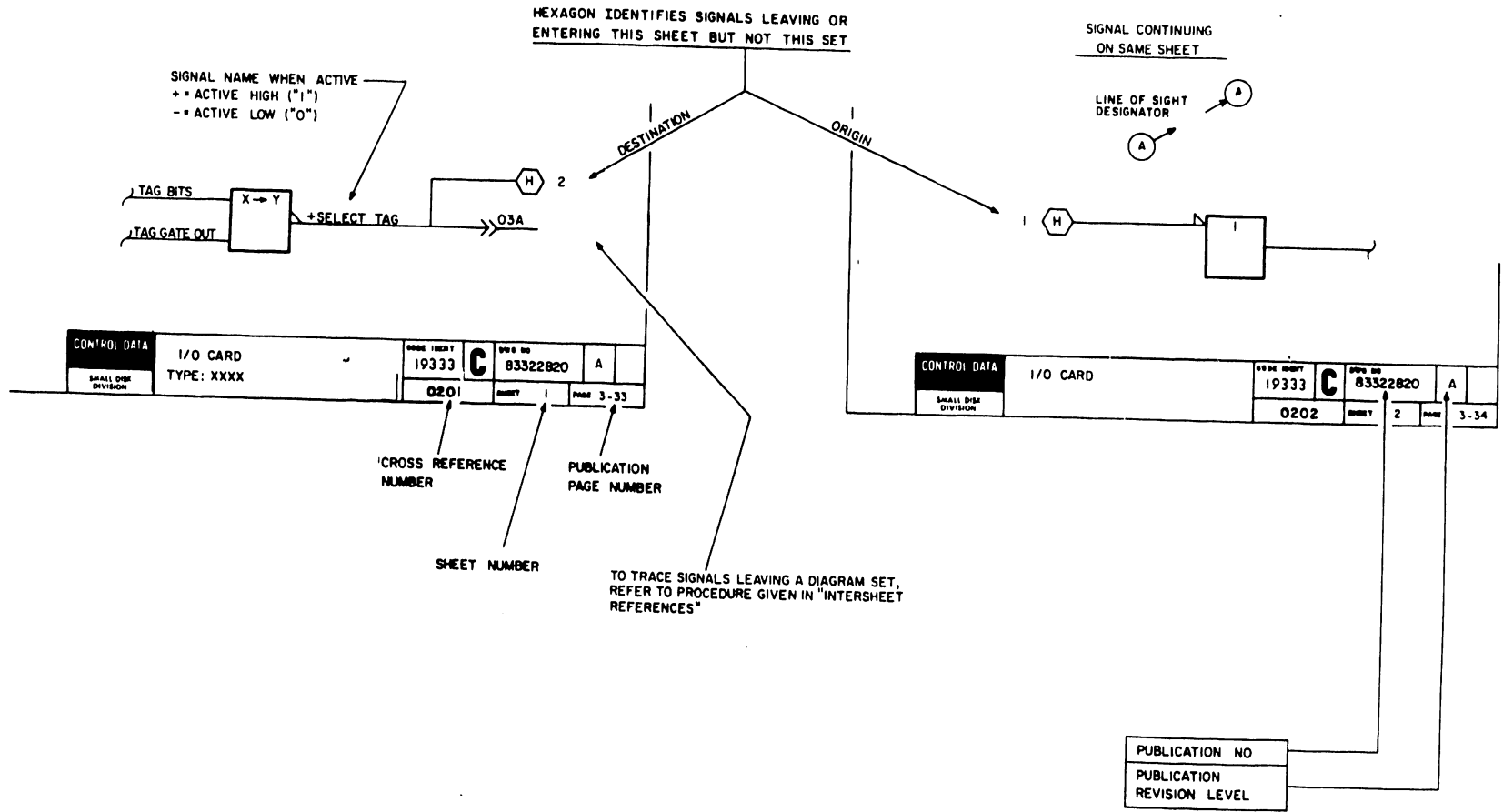

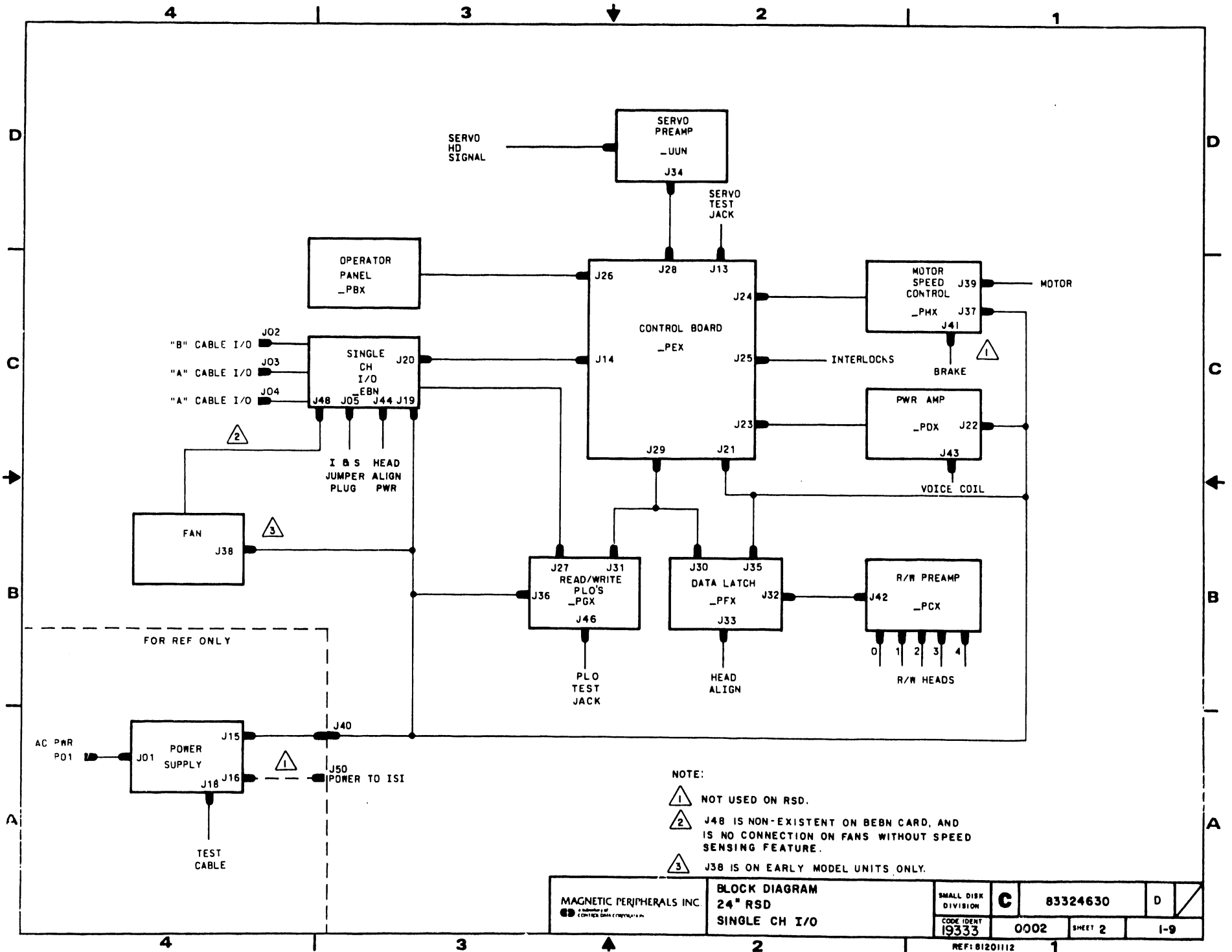

NOTE:

- 1 NOT USED ON RSD.
- 2 J48 IS NON-EXISTENT ON BEBN CARD, AND IS NO CONNECTION ON FANS WITHOUT SPEED SENSING FEATURE.
- 3 J38 IS ON EARLY MODEL UNITS ONLY.

MAGNETIC PERIPHERALS INC. <small>Member of CONTROL DATA CORPORATION</small>	BLOCK DIAGRAM 24" RSD SINGLE CH I/O		SMALL DISK DIVISION C	83324630	D
	CODE IDENT 19333	0002	SHEET 2	I-9	

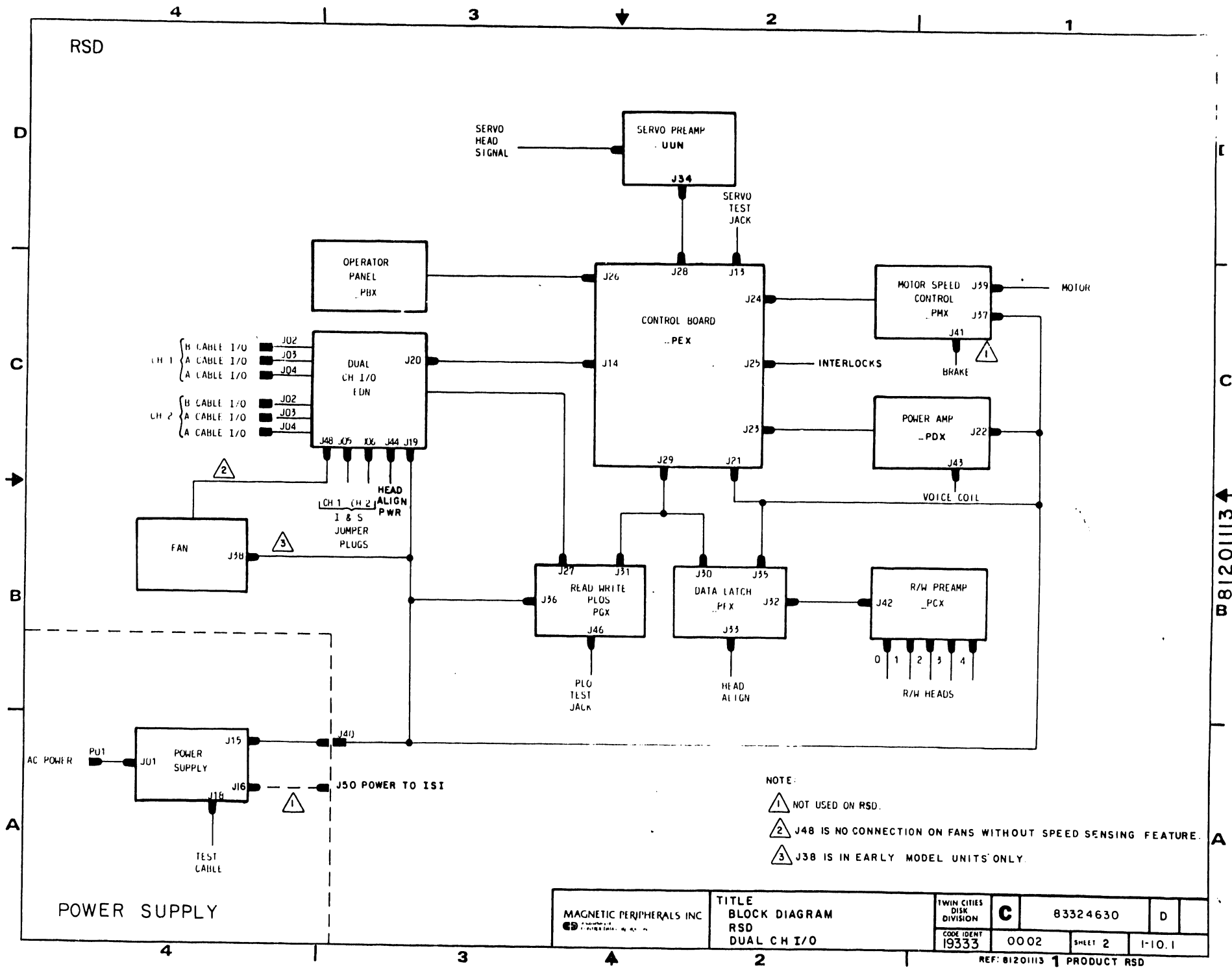

NOTE:

- ① NOT USED ON RSD.
- ② J48 IS NO CONNECTION ON FANS WITHOUT SPEED SENSING FEATURE.
- ③ J38 IS IN EARLY MODEL UNITS ONLY.

POWER SUPPLY

MAGNETIC PERIPHERALS INC 95	TITLE BLOCK DIAGRAM RSD DUAL CH I/O		TWIN CITIES DISK DIVISION	C	83324630	D
	CODE IDENT 19333	0002	SHEET 2	1-10.1		

B8120113

SIGNAL INPUTS

0402 J26-02 -02->> P26
0402 J26-04 -04->> P26
0402 J26-01 -01->> P26
0402 J26-06 -06->> P26

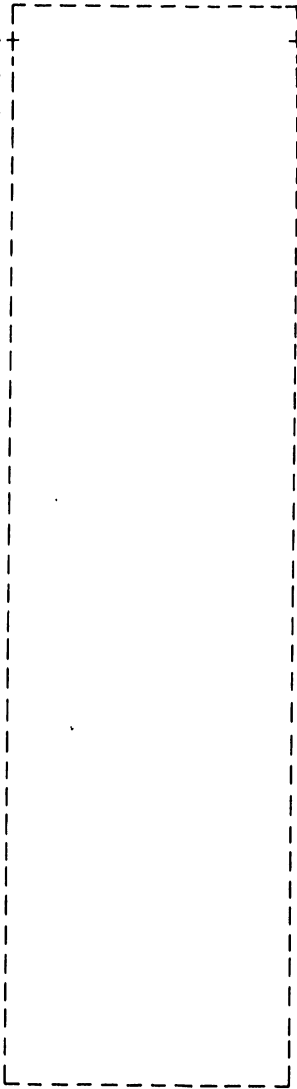

SIGNAL OUTPUTS

LOGIC CROSS REFERENCE INFORMATION

PUB	83324630	REV	B
CROSS REF NO	0101	PAGE	1-10,2

PART NO. RANGE	REVISION RECORD						
	REV	ECO	DESCRIPTION	DRFT	DATE	CHKD	APP
00 THRU 99	01	DJD3028A	PRE-RELEASED		4/29/82	DS	II
	A	DYZ3028 DJD3028B	RELEASED	DEM	8/18/82	DGD	III
	B	DJD3100	ADDITION SHIT 2.	DEM	8/27/82	EMS	II

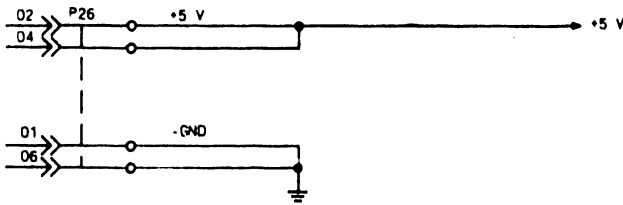

REFERENCE DRAWING			MAGNETIC PERIPHERALS INC.			TITLE		
COMP. ASSY. 54330902			A member of COMPTON DATA CORPORATION			SCHEMATIC DIAGRAM		
CTR 54331102			FIRST USED ON		NEXT ASSEMBLY		OPERATOR PANEL	
			PA3A1-A				TYPE CPBX	
COMPONENTS EXCEPT AS NOTED			DWN	FAE AUDETTE	11/23/81	SIZE		
TOLERANCE	VALUE	RATING	CHKD	DGD	4-16-82	SMALL DISK DIVISION	C	83324630
RES			ENGR	RS	4-16-82			A
CAP			MFG	W.H.	8/2/82			
			QA	M. H.	8/2/82	PRGM. NO.	19333	
						OIOI	SHEET 1 OF 3	PAGE 1-11

SIGNAL INPUTS

0405 J26-07 07 ->> P26
0409 J26-13 13 ->> P26
0409 J26-12 12 ->> P26

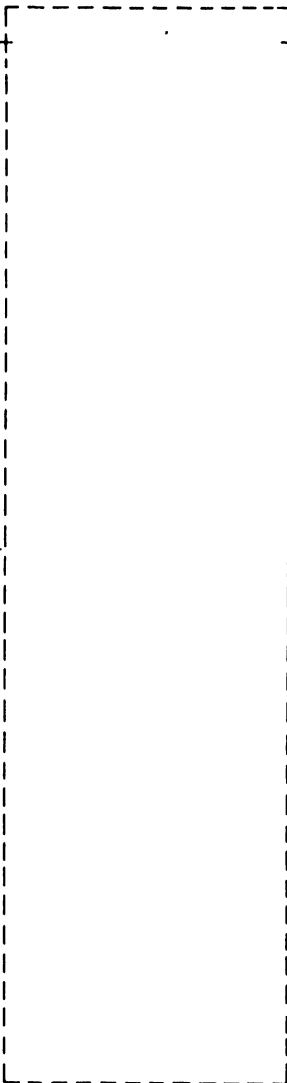

SIGNAL OUTPUTS

P26 ->> 05 0405 J26-05
P26 ->> 03 0405 J26-03
P26 ->> 09 0405 J26-09
P26 ->> 11 0402 J26-11
P26 ->> 08 0407 J26-08
P26 ->> 10 0408 J26-10
P26 ->> 14 0409 J26-14

LOGIC CROSS REFERENCE INFORMATION

PUB		REV
83324630		B
CROSS REF NO	PAGE	
0102	1-12	

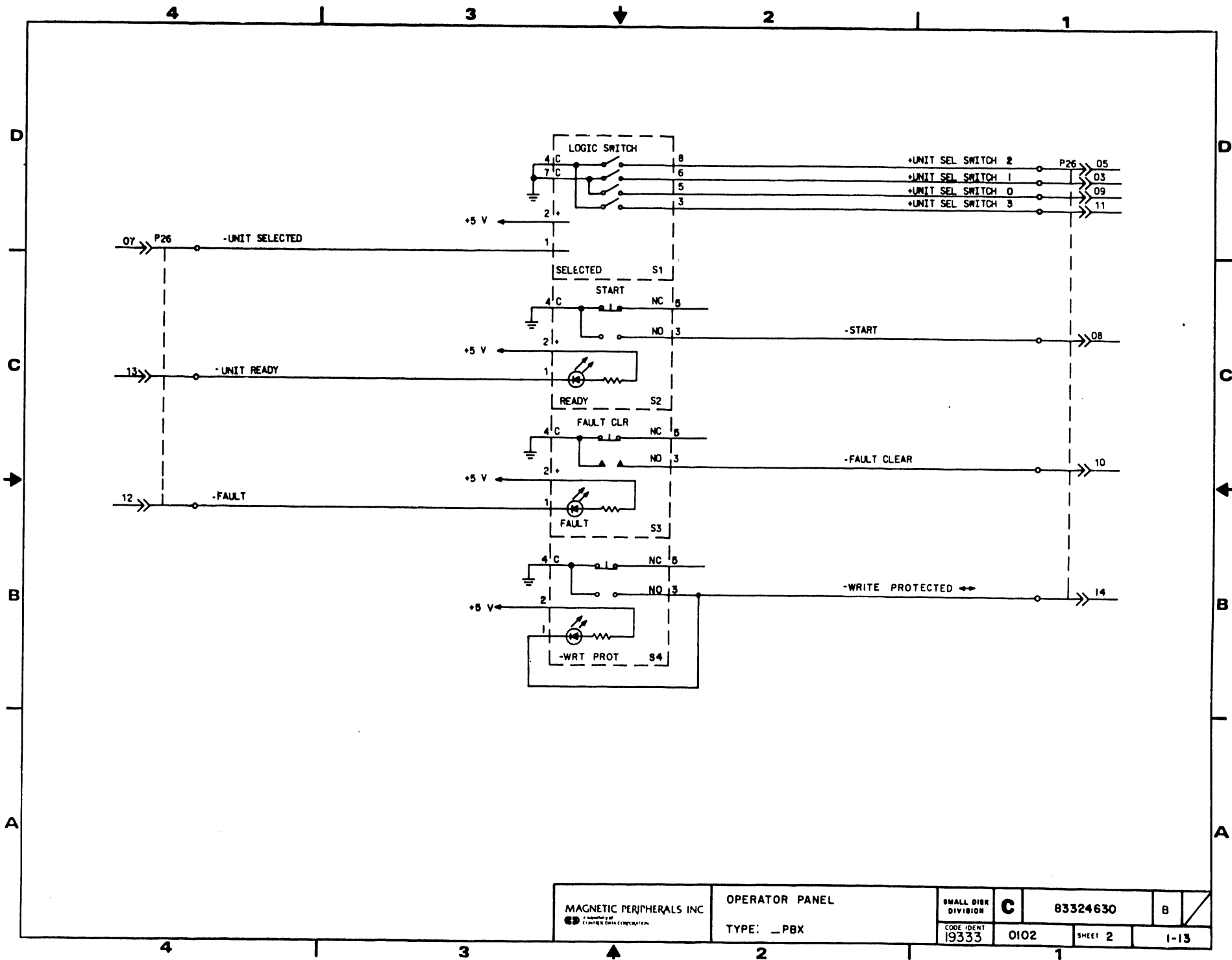

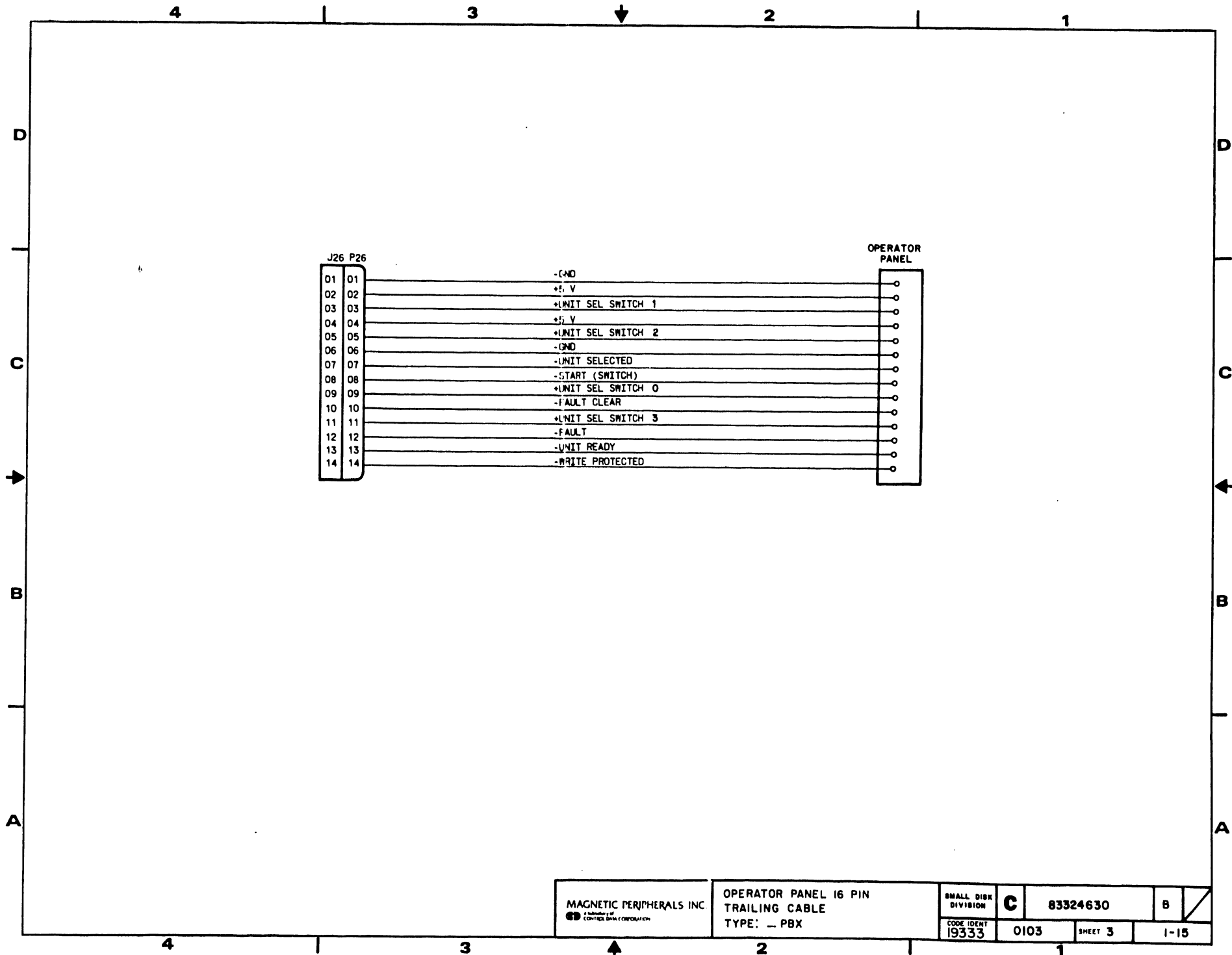

SIGNAL INPUTS

1002	J40-11	05	>>	J19
NC	-	07	>>	J19
1002	J40-01	08	>>	J19
1002	J40-02	03	>>	J19
NC	-	04	>>	J19
1002	J40-03	01	>>	J19
1002	J40-15	06	>>	J19
NC	-	02	>>	J19

SIGNAL OUTPUTS

J44	04	>>	Head Alignment Test Jack
J44	06	>>	Head Alignment Test Jack
J44	03	>>	Head Alignment Test Jack
J44	01	>>	Head Alignment Test Jack
J44	05	>>	Head Alignment Test Jack

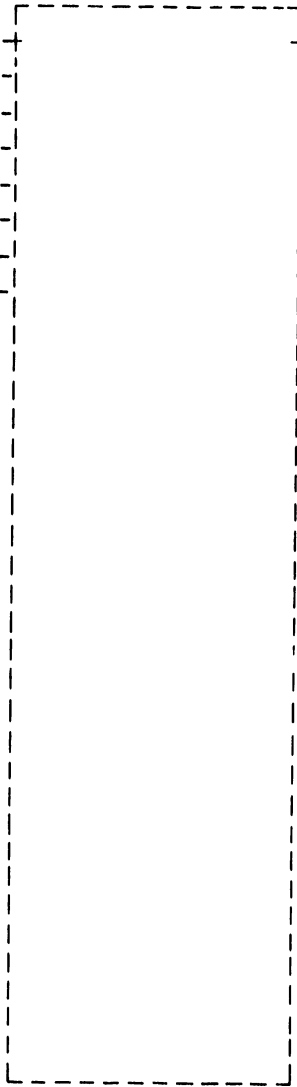

LOGIC CROSS REFERENCE INFORMATION

PUB		83324630	REV	B
CROSS REF NO	0201	PAGE		1-16

UNUSED LOGIC ELEMENTS

TYPE	LOCATION	OUTPUT PINS
10125	C204	12, 1
9602	E844	9, 10
74LS04	E865	8, 9, 10
74LS02	E855	13
7404	C821	8
4049	D811	2, 6, 10, 15
10125	C902	12

UNUSED RESISTOR PACKS

VALUE	LOCATION	PINS
1 k Ω	E543	2, 3, 5, 7
1 k Ω	E055	8
82 Ω	B844	6, 7, 8
470 Ω	C009	4, 5, 8
1 k Ω	D332	6, 7, 8

FILTER CAPS ²

.1 μ F	
+5 V	-5 V
C721	B322
A525	C733
C021	C611
B333	E045
D257	A625
E657	C756
C633	E745
C711	D245
D225	D357
D945	D956
C645	C745
	C621

PART NO RANGE	REVISION RECORD						
	REV	ECD	DESCRIPTION	DRFT	DATE	CHKD	APP
00 THRU 99	01	DJ0319A	PRE-RELEASED		4/2/82	DGD	II
	02	D501056	CHG IC SMT 5	DLM	4/21/82	DGD	II
	03	DJ03083	LSI PIN 14 GND	DLM	4/24/82	DGD	II
	04	J30303	KEY J14/GND	DLM	7/26/82	DGD	II
	A	DJ03083	RELEASED				
	B	DJ03132	CORRECTIONS	DLM	10-15-82	DGD	III
	C	DJ03177	CORRECTIONS	KKB	12-15-82		
	D	DJ03237	REPLACE CHIP	MJ	3/17/83		
	E	DJ03355	CORRECTIONS	MJ	7/14/83		

NOTES:

- UNLESS OTHERWISE SPECIFIED:
ALL 14 PIN IC'S HAVE PIN 7 CONNECTED TO GND
AND PIN 14 CONNECTED TO +5 V.
ALL DIODES, 15165500.
ALL RESISTOR PACK RESISTORS 1/8 W. \pm 3%.
- SEE TABLE FOR FILTER CAP LOCATIONS.
- J05 IS A/B CABLE JUMPER.

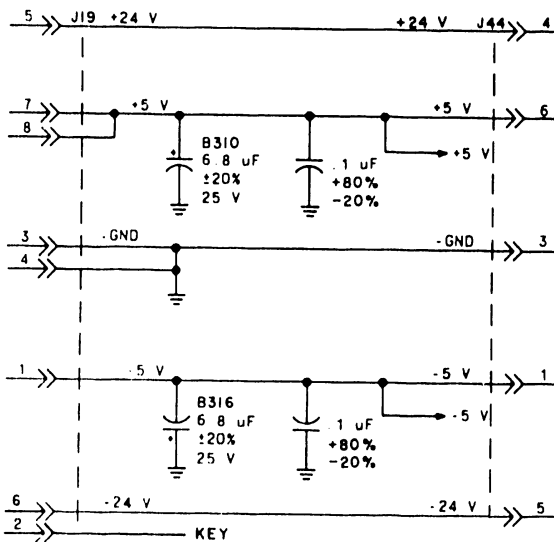

APPLIES TO SINGLE CHANNEL UNITS ONLY.

REFERENCE DRAWING		MAGNETIC PERIPHERALS INC		TITLE	
COMP ASSY 54020501		GND CONTROL DATA CORPORATION		SCHEMATIC DIAGRAM	
CTR 54020701		FIRST USED ON	NEXT ASSEMBLY	SINGLE CH SMD I/O	
		PA3A1-A		TYPE BEBN	
COMPONENTS EXCEPT AS NOTED		DWN	DLM	3/1/82	
TOLERANCE	VALUE	RATING	CHKD	Dennis G. Donat	4/30/82
RES \pm 5%	OHMS	1/4 W	ENGR	R. J. Anderson	4/10/82
CAP \pm 10%			MFG	P. M. Bantz	5/24/82
			DA	L. J. ...	1/21/82
		SMALL DISK DIVISION		C	83324630
		FORM NO 19333		0201	SHEET 1 OF 7
		REF: 54020601		1	PAGE 1-17
		PRODUCT RSD/FSD			

SIGNAL INPUTS

0405 J14-10 ~~21~~ >> ~~J20~~

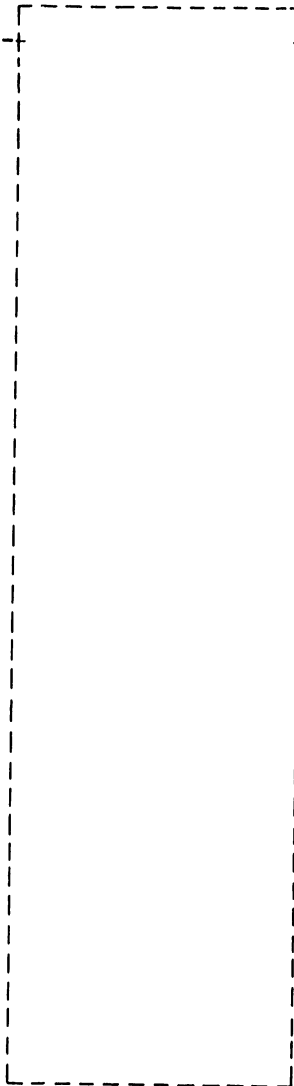

SIGNAL OUTPUTS

J20 >> 05	0405 J14-18
J20 >> 07	0405 J14-17
P27 >> 18	0701 J27-18
P27 >> 19	0702 J27-19
P27 >> 20	0702 J27-20
P27 >> 16	0702 J27-16
P27 >> 17	0702 J27-17
P27 >> 15	0701 J27-15
J20 >> 11	0405 J14-15
J20 >> 13	0405 J14-14
J20 >> 15	0405 J14-13
J20 >> 19	0405 J14-11

LOGIC CROSS REFERENCE INFORMATION

PUB 83324630		REV A
CROSS REF NO 0202	PAGE 1-18	

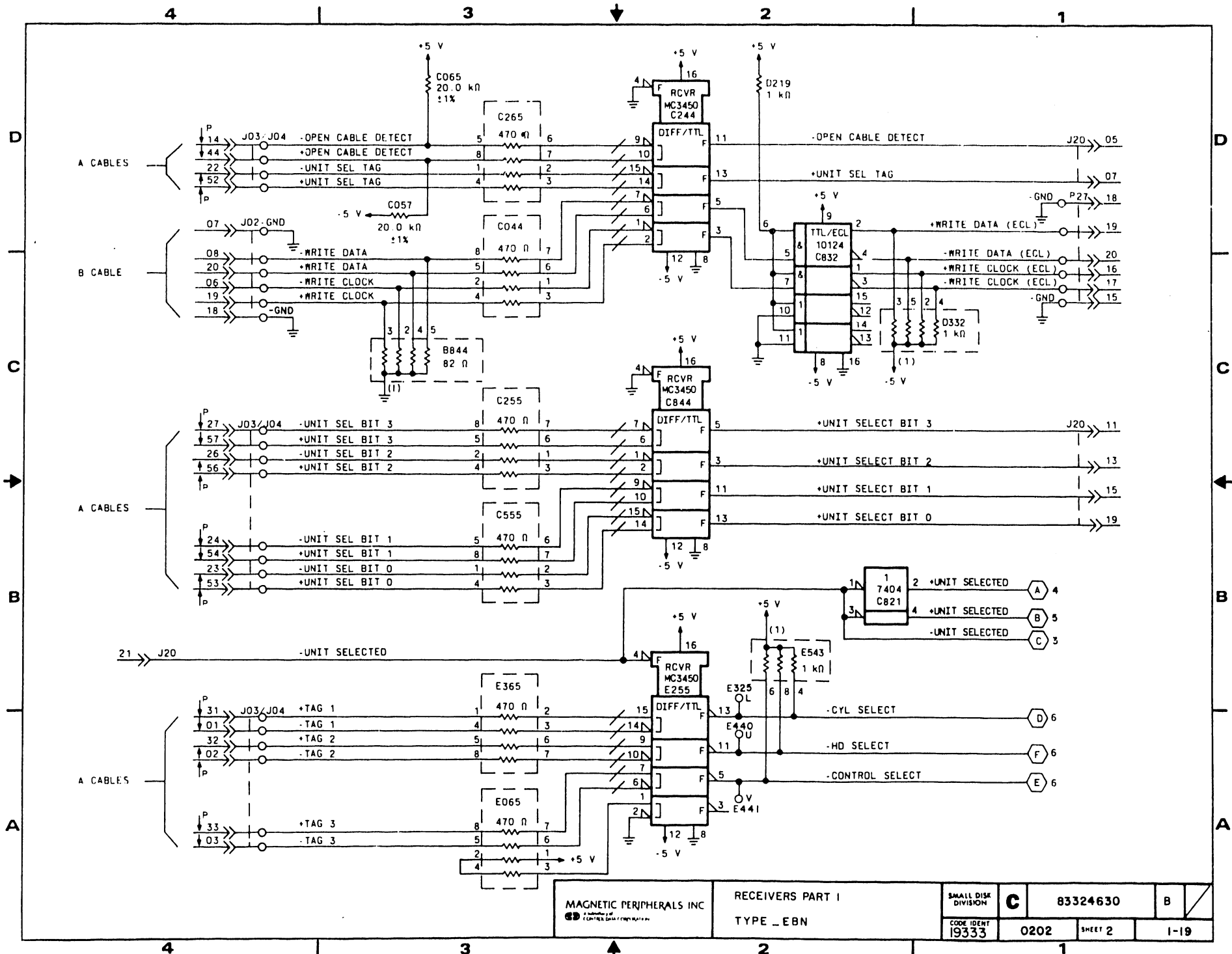

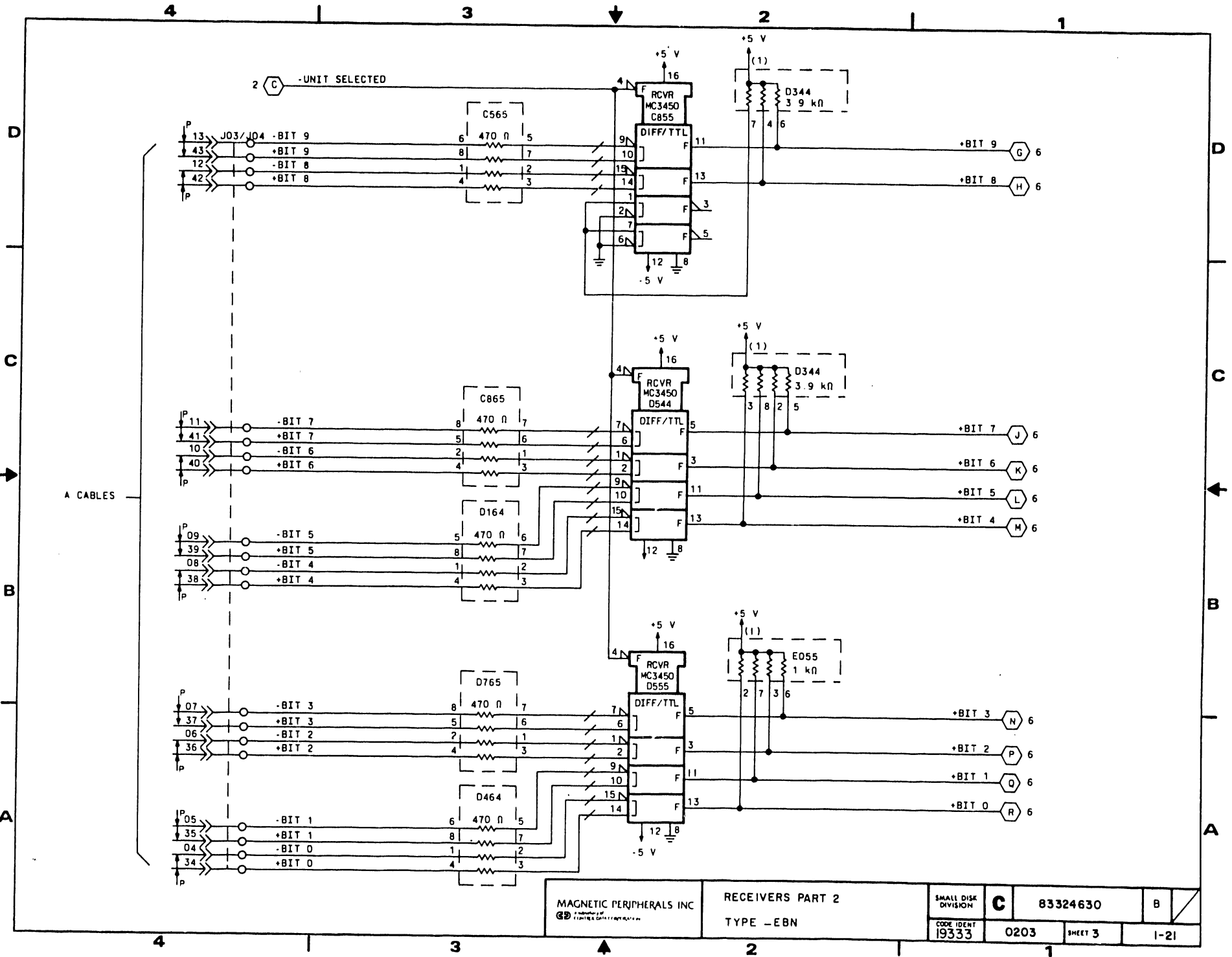

SIGNAL INPUTS

0410 J14-20 -01-->--J20
0410 J14-35 -30-->--J20
0409 J14-24 -08-->--J20
0406 J14-12 -17-->--J20
0705 J27-05 -05-->--P27

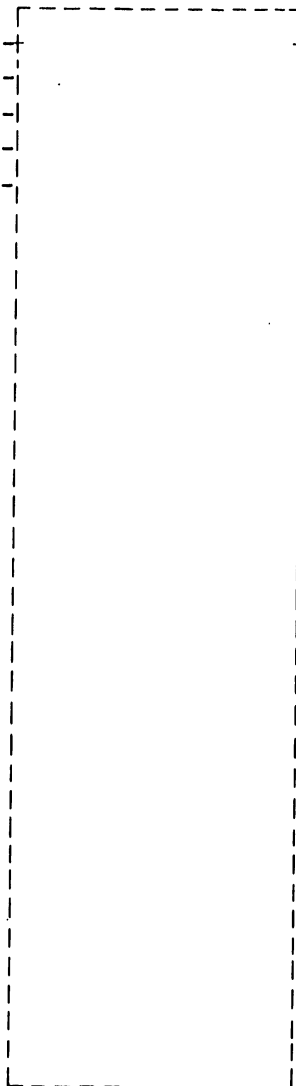

SIGNAL OUTPUTS

LOGIC CROSS REFERENCE INFORMATION

PUB 83324630		REV A
CROSS REF NO 0204	PAGE 1-22	

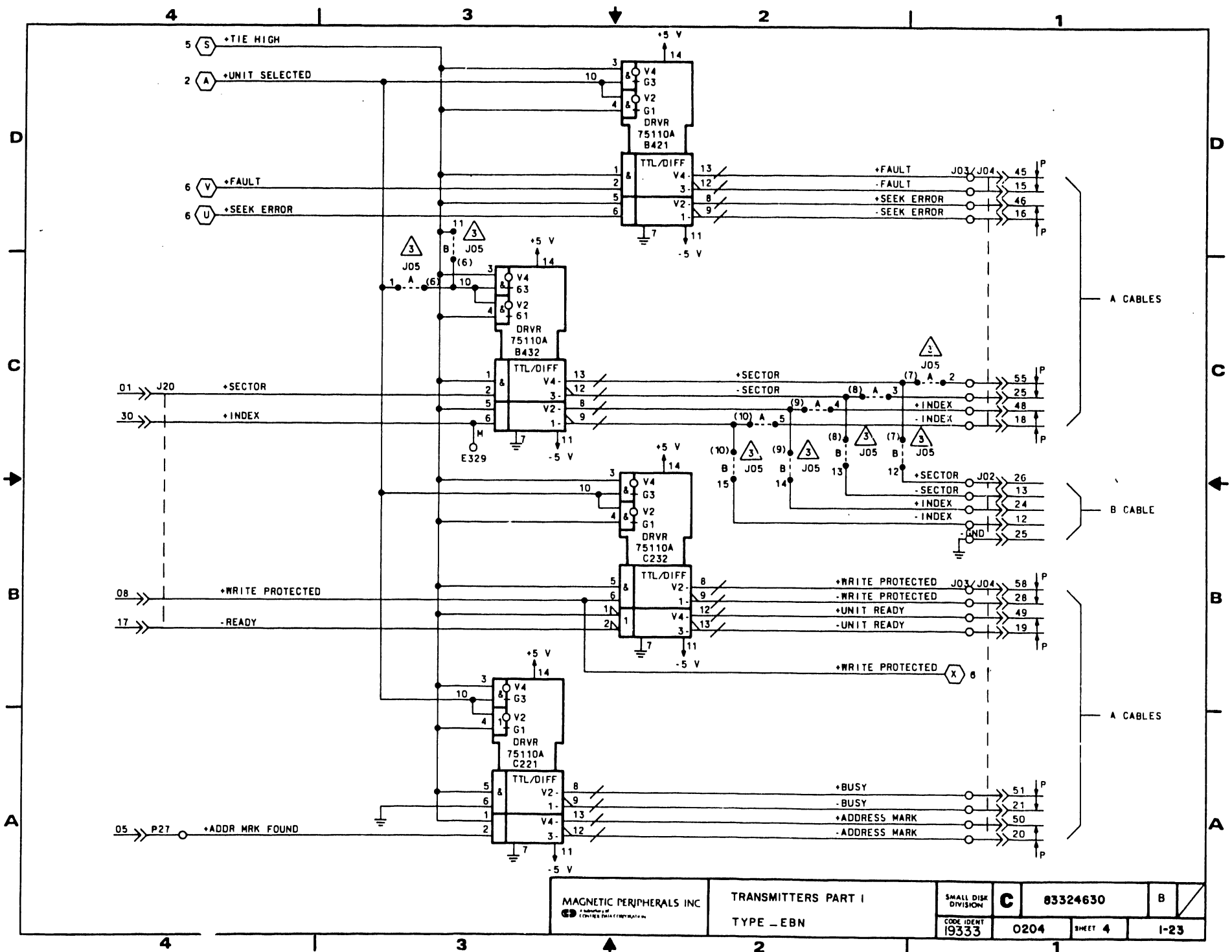

SIGNAL INPUTS

0703 J27-01 01 ->> P27
0703 J27-02 02 ->> P27
0702 J27-14 14 ->> P27
0702 J27-13 13 ->> P27
0702 J27-11 11 ->> P27
0702 J27-10 10 ->> P27
0701 J27-12 12 ->> P27
0410 J14-16 09 ->> J20

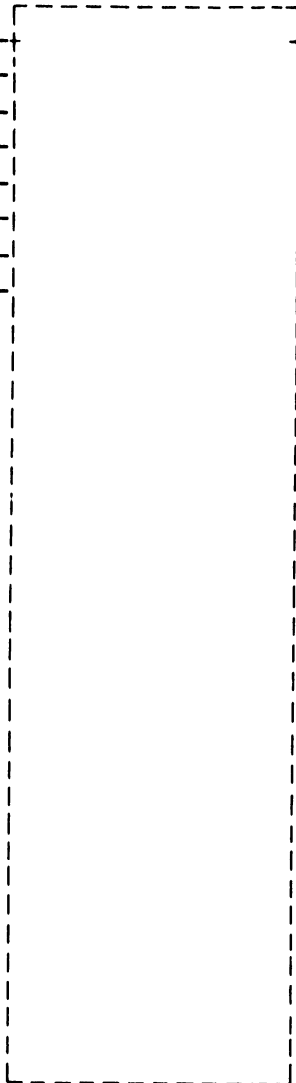

SIGNAL OUTPUTS

J20 ->> 20 0407 J14-30

LOGIC CROSS REFERENCE INFORMATION

PUB		REV
83324630		A
CROSS REF NO	PAGE	
0205	1-24	

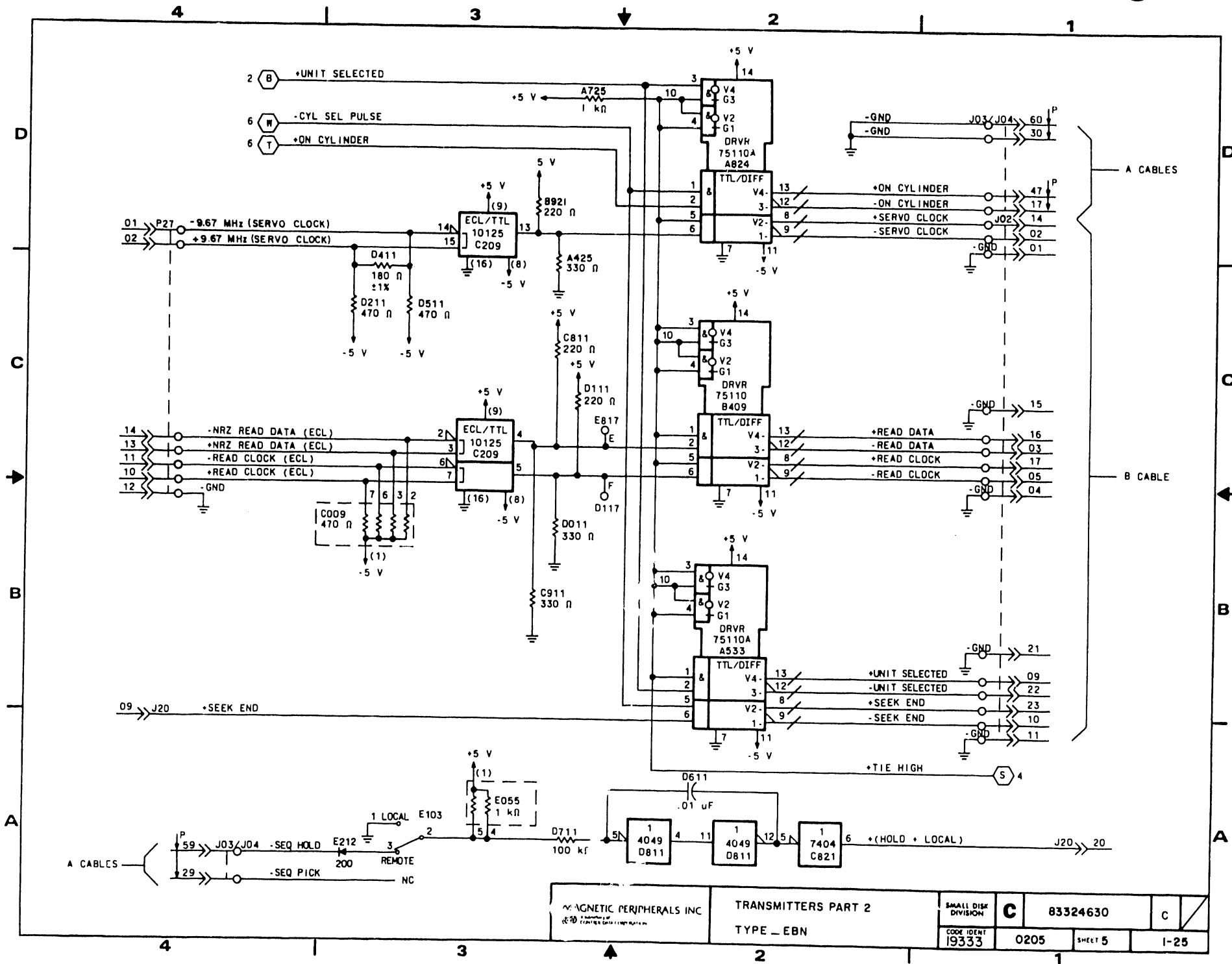

SIGNAL INPUTS

0409	J14-31	22	>>	J20
0406	J14-08	25	>>	J20
0406	J14-09	23	>>	J20
0403	J14-29	18	>>	J20
0704	J27-08	08	>>	P27

SIGNAL OUTPUTS

J20	>>	26	0406	J14-33
J20	>>	03	0410	J14-19
J20	>>	06	0410	J14-23
P27	>>	09	0704	J27-09
P27	>>	07	0702	J27-07
J20	>>	12	0409	J14-26
P27	>>	06	0704	J27-06
P27	>>	04	0705	J27-04
P27	>>	03	0705	J27-03
J20	>>	28	0406	J14-34
J20	>>	39	0406	J14-01
J20	>>	37	0406	J14-02
J20	>>	35	0406	J14-03
J20	>>	33	0406	J14-04
J20	>>	31	0406	J14-05
J20	>>	38	0418	J14-39
J20	>>	40	0418	J14-40
J20	>>	10	0406	J14-25

LOGIC CROSS REFERENCE INFORMATION

PUB		REV	
83324630		B	
CROSS REF NO	PAGE		
0206	1-26		

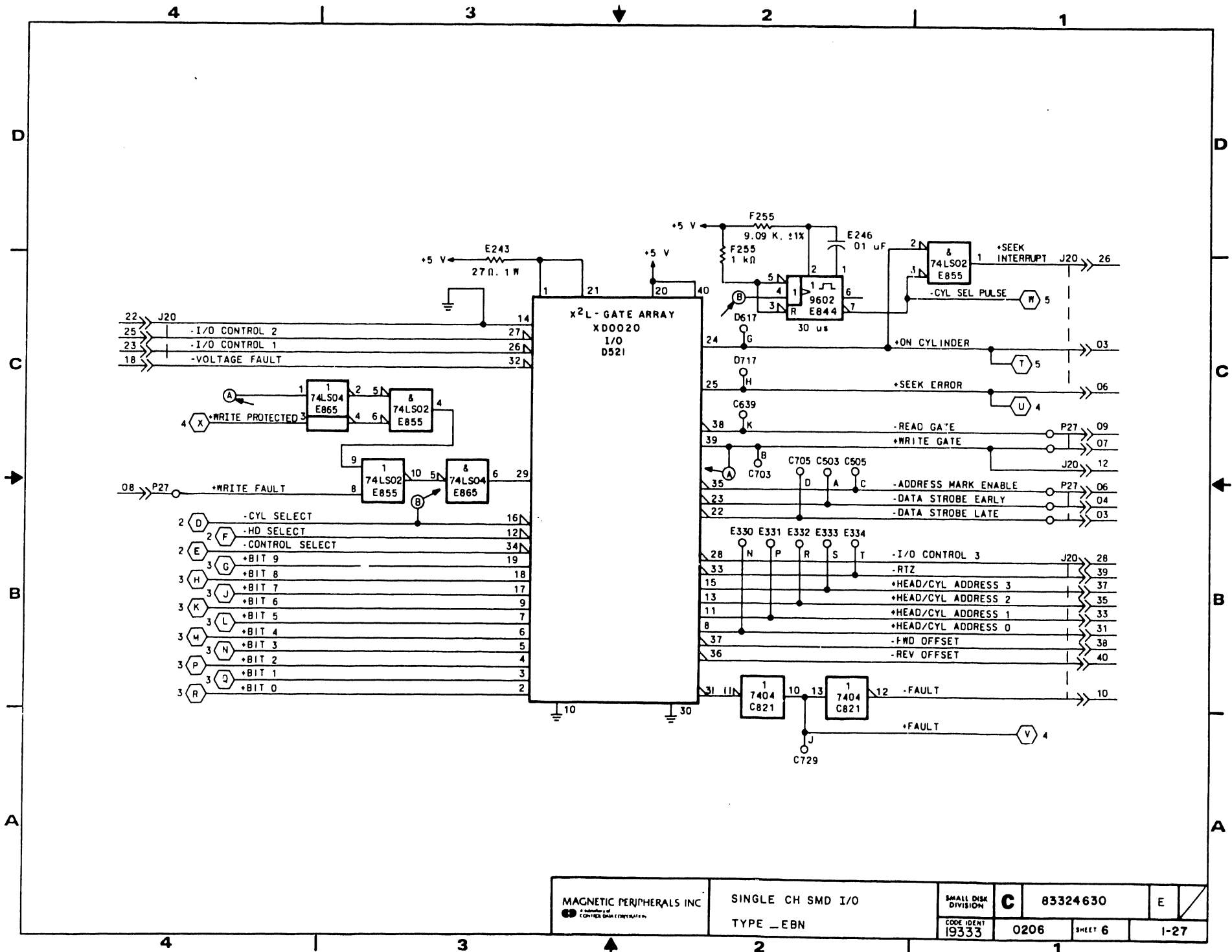

MAGNETIC PERIPHERALS INC A Division of CONTECH DATA CORPORATION	SINGLE CH SMD I/O TYPE _EBN	SMALL DISK DIVISION	C	83324630	E
		CODE IDENT 19333			

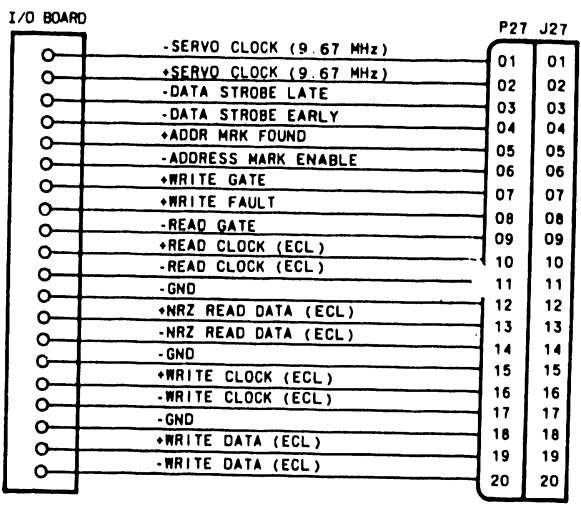
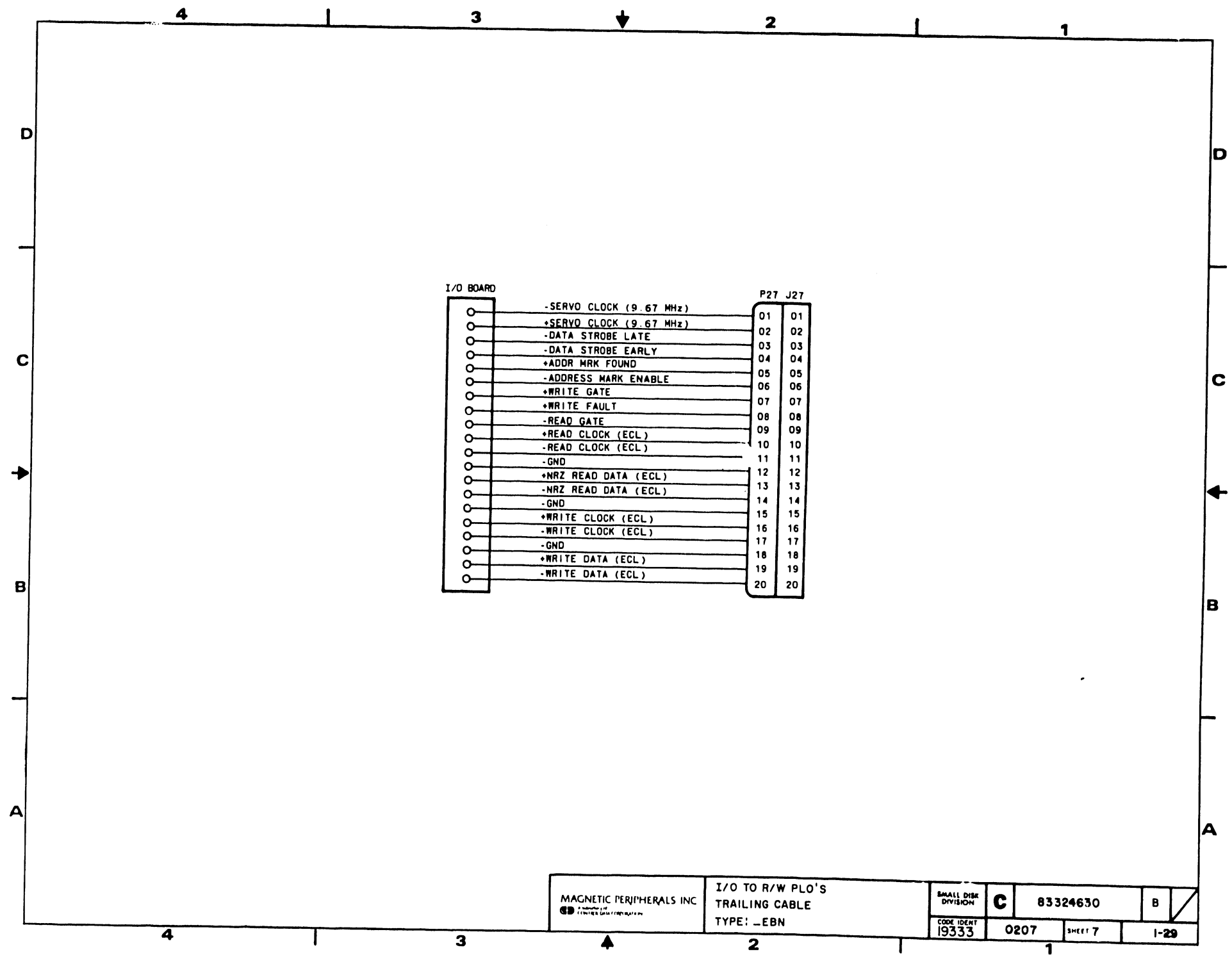

MAGNETIC PERIPHERALS INC A member of GE	I/O TO R/W PLO'S TRAILING CABLE TYPE: _EBN	SMALL DISK DIVISION	C	83324630	B
		CODE IDENT 19333	0207	SHEET 7	1-29

SIGNAL INPUTS

1002	J40-11	05	>>	J19	-----
NC	-	07	>>	J19	-----
1002	J40-01	08	>>	J19	-----
1002	J40-02	03	>>	J19	-----
NC	-	04	>>	J19	-----
From Fan		04	>>	J48	-----
From Fan		02	>>	J48	-----
1002	J40-03	01	>>	J19	-----
1002	J40-15	06	>>	J19	-----
NC	-	02	>>	J19	-----

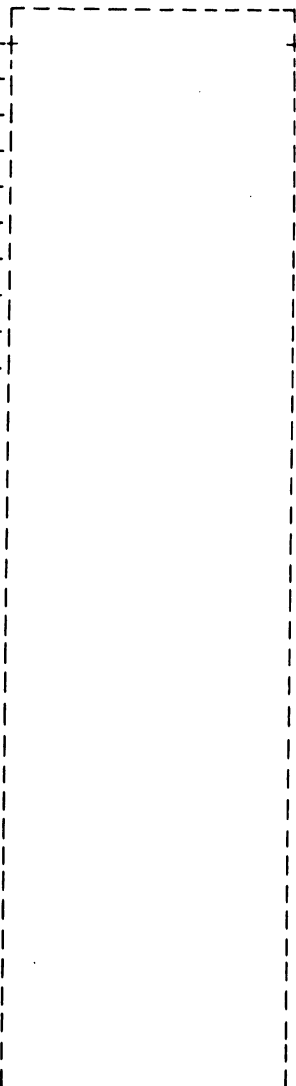

SIGNAL OUTPUTS

J44	>>	04	Head Alignment Test Jack
J44	>>	02	Head Alignment Test Jack
J44	>>	06	Head Alignment Test Jack
J44	>>	03	Head Alignment Test Jack
J44	>>	01	Head Alignment Test Jack
J44	>>	05	Head Alignment Test Jack

LOGIC CROSS REFERENCE INFORMATION

PUB		REV
83324630		B
CROSS REF NO	PAGE	
0201	1-30	

UNUSED LOGIC ELEMENTS

TYPE	LOCATION	OUTPUT PINS
10125	C209	12, 1
7404	C821	8
74LS04	E865	10, 12

UNUSED RESISTOR PACKS

VALUE	LOCATION	PINS
1 k Ω	E543	2, 5, 7
1 k Ω	E155	8
56 Ω	B944	6, 7, 8
470 Ω	C009	4, 5, 8
1 k Ω	D332	6, 7, 8
47 k Ω	E365	2, 4, 8
47 k Ω	C865	3, 4, 5

FILTER CAPS ²

.1 μ F	
+5 V	-5 V
C721	B323
A525	C733
C021	C611
B333	E045
D257	A625
E658	C756
C633	E745
C711	D245
D225	D357
D945	D956
B235	B133
D165	C621
	C765

PART NO RANGE	REVISION RECORD						
	REV	ECO	DESCRIPTION	DRFI	DATE	CHKD	APP
02 THRU 02	A	0J23000	RELEASED		1-3-82		
	B	DJ03276	SCH CHGS	DLM	2-16-82		
	C	DJ03319	ADD FAN FAULT GND.	MJ	5-12-82		
	D	DJ03355	CORRECTIONS	MJ	1-14-83		
	E	DJ03392	CEBN \rightarrow EEBN	MJ	10-13-83		
	F	DJ03474	RESISTOR CHANGES	CB	1-13-84		

- NOTES:
- UNLESS OTHERWISE SPECIFIED:
ALL 14 PIN IC'S HAVE PIN 7 CONNECTED TO GND AND PIN 14 CONNECTED TO +5 V.
ALL DIODES, 15165580.
ALL TRANSISTORS, 2N3646, PNP, 50210310.
ALL RESISTOR PACK RESISTORS 1/8 W. \pm 3%.
 - SEE TABLE FOR FILTER CAP LOCATIONS.
 - J05 IS A/B CABLE JUMPER.
 - DELAY TIME FOR REFERENCE ONLY.
 - ALL \bigcirc - \bigcirc INDICATES MOLDED JUMPER WIRES.

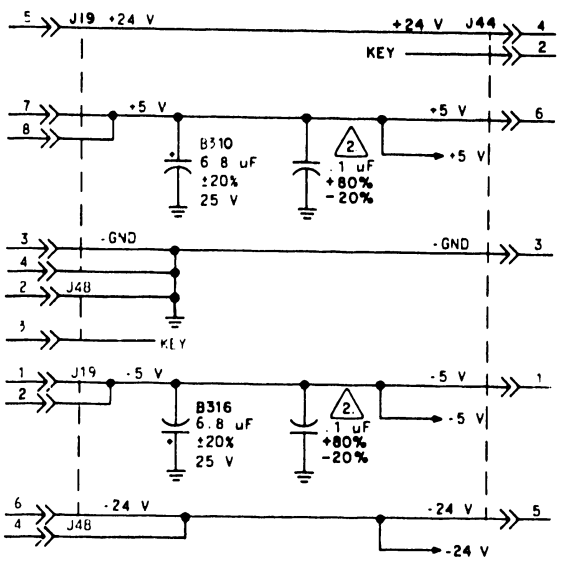

APPLIES TO SINGLE CHANNEL UNITS ONLY.

REFERENCE DRAWING			MAGNETIC PERIPHERALS INC		TITLE		
COMP ASSY 54020502			A Division of		SCHEMATIC DIAGRAM		
CTR 54020702			CENTRAL DATA CORPORATION		SINGLE CH SMD I/O		
			FIRST USED ON	NEXT ASSEMBLY	TYPE CEBN/EEBN		
			PA3A1-A				
COMPONENTS EXCEPT AS NOTED			DWN	C Semakula	11-22-82	SIZE	
TOLERANCE	VALUE	RATING	CHKD	DG D-m-1	12-7-82	TWIN CITIES	
RES \pm 5%	OHMS	1/4 W	ENGR	9-6-7-82	DISK	C	83324630
CAP \pm 10%			MFG	1-7-82	DIVISION		E
			QA	7-1-82	PSCM NC	19333	0201
							SHEET 1 of 7
							PAGE 1-30.1

SIGNAL INPUTS

0405 J14-10 21 ->> J20

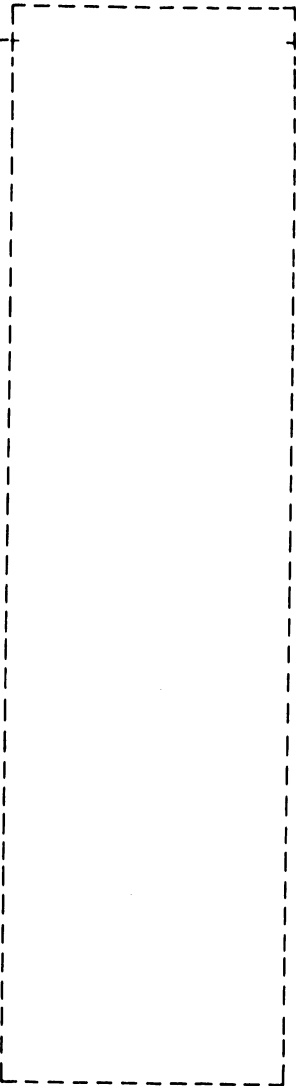

SIGNAL OUTPUTS

J20	->>	05	0405	J14-18
J20	->>	07	0405	J14-17
P27	->>	18	0701	J27-18
P27	->>	19	0702	J27-19
P27	->>	20	0702	J27-20
P27	->>	16	0702	J27-16
P27	->>	17	0702	J27-17
P27	->>	15	0701	J27-15
J20	->>	11	0405	J14-15
J20	->>	13	0405	J14-14
J20	->>	15	0405	J14-13
J20	->>	19	0405	J14-11

LOGIC CROSS REFERENCE INFORMATION

PUB 83324630		REV B
CROSS REF NO 0202	PAGE 1-30.2	

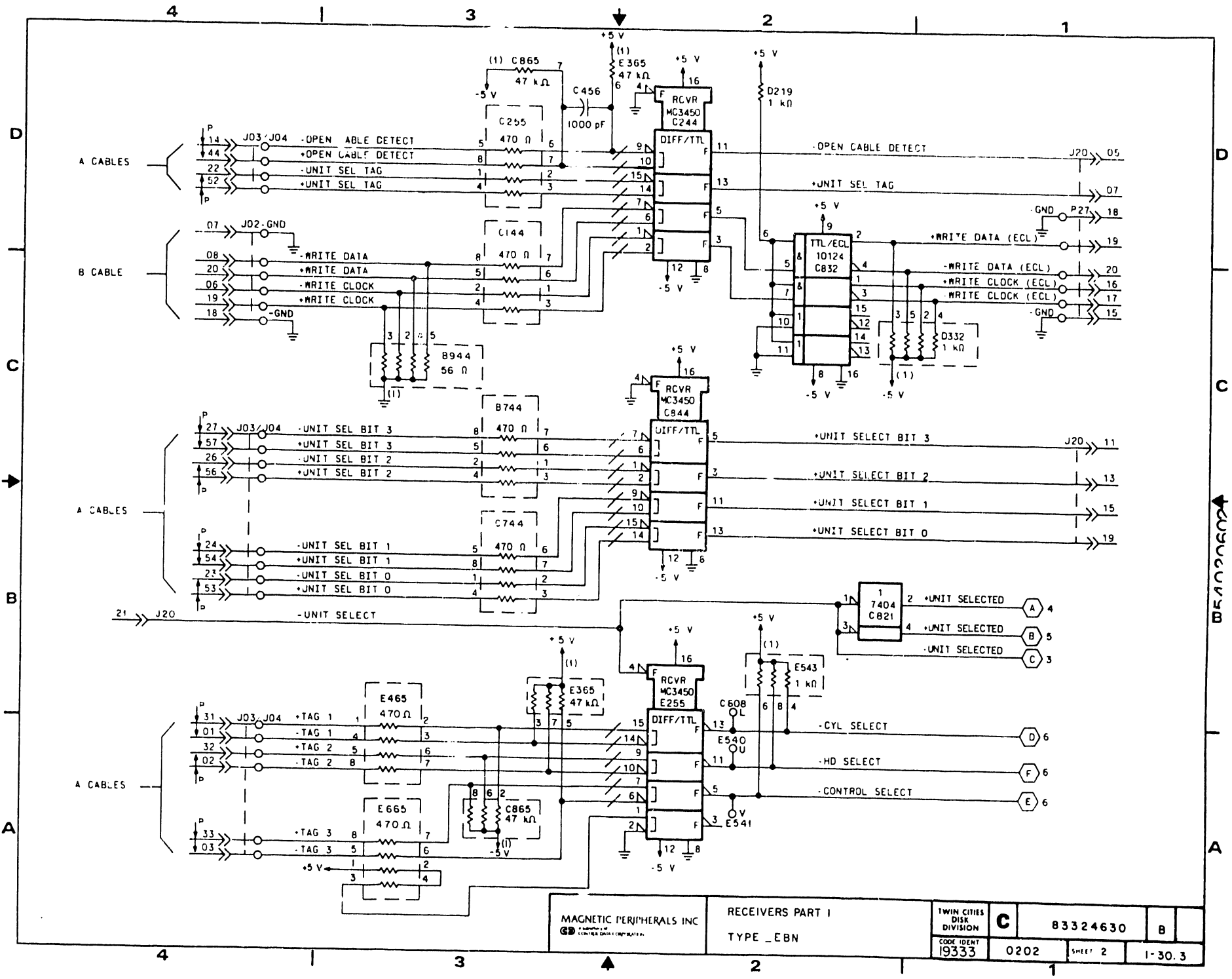

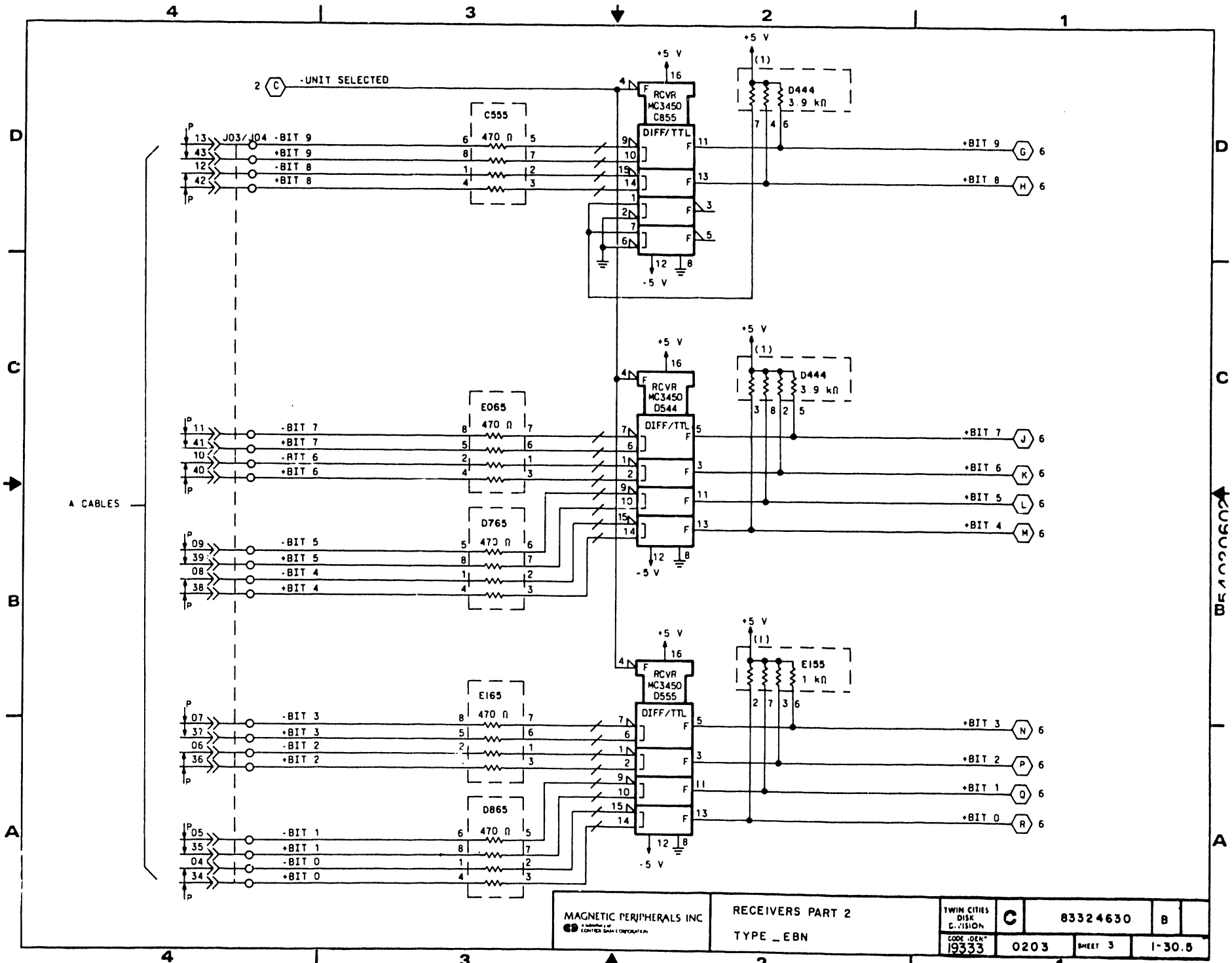

SIGNAL INPUTS

0410 J14-20 01 ->> J20
0410 J14-35 30 ->> J20
0409 J14-24 08 ->> J20
0406 J14-12 17 ->> J20
0705 J27-05 05 ->> P27

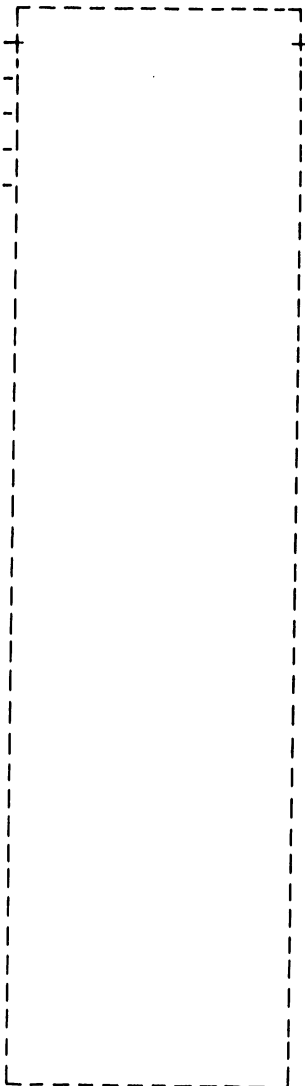

SIGNAL OUTPUTS

LOGIC CROSS REFERENCE INFORMATION

PUB	83324630	REV	B
CROSS REF NO	0204	PAGE	1-30.6

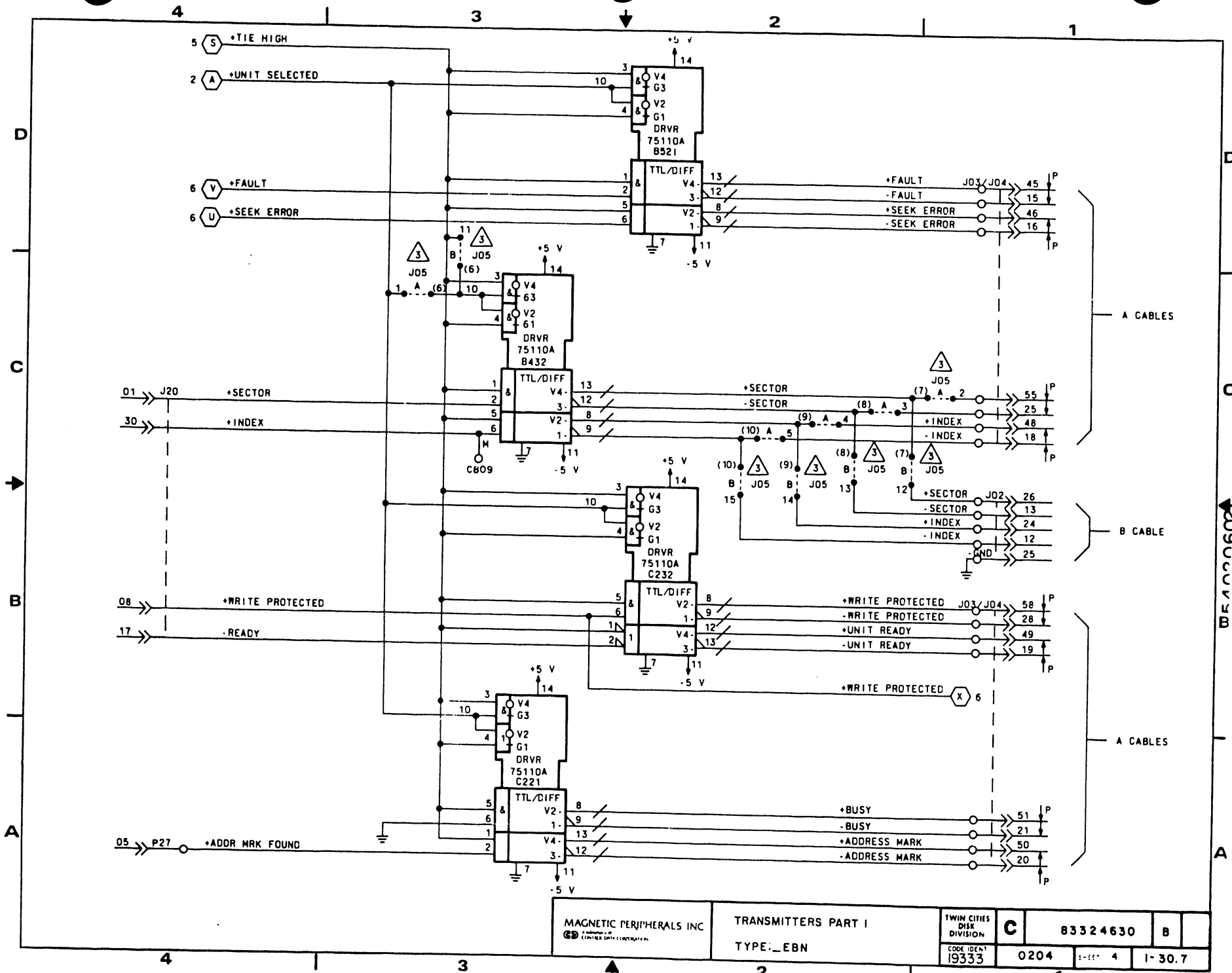

MAGNETIC PERIPHERALS INC <small>MEMBER OF GTE SYSTEMS CORPORATION</small>	TRANSMITTERS PART 1	TWIN CITIES DISK DIVISION	C	83324630	B
	TYPE: EBN	CODE IDENT 19333			

SIGNAL INPUTS

0703	J27-01	01	>>	P27
0703	J27-02	02	>>	P27
0702	J27-14	14	>>	P27
0702	J27-13	13	>>	P27
0702	J27-11	11	>>	P27
0702	J27-10	10	>>	P27
0701	J27-12	12	>>	P27
0410	J14-16	09	>>	J20

SIGNAL OUTPUTS

J20 >> 20 0407 J14-30

LOGIC CROSS REFERENCE INFORMATION

PUB 83324630		REV B
CROSS REF NO 0205	PAGE 1-30.8	

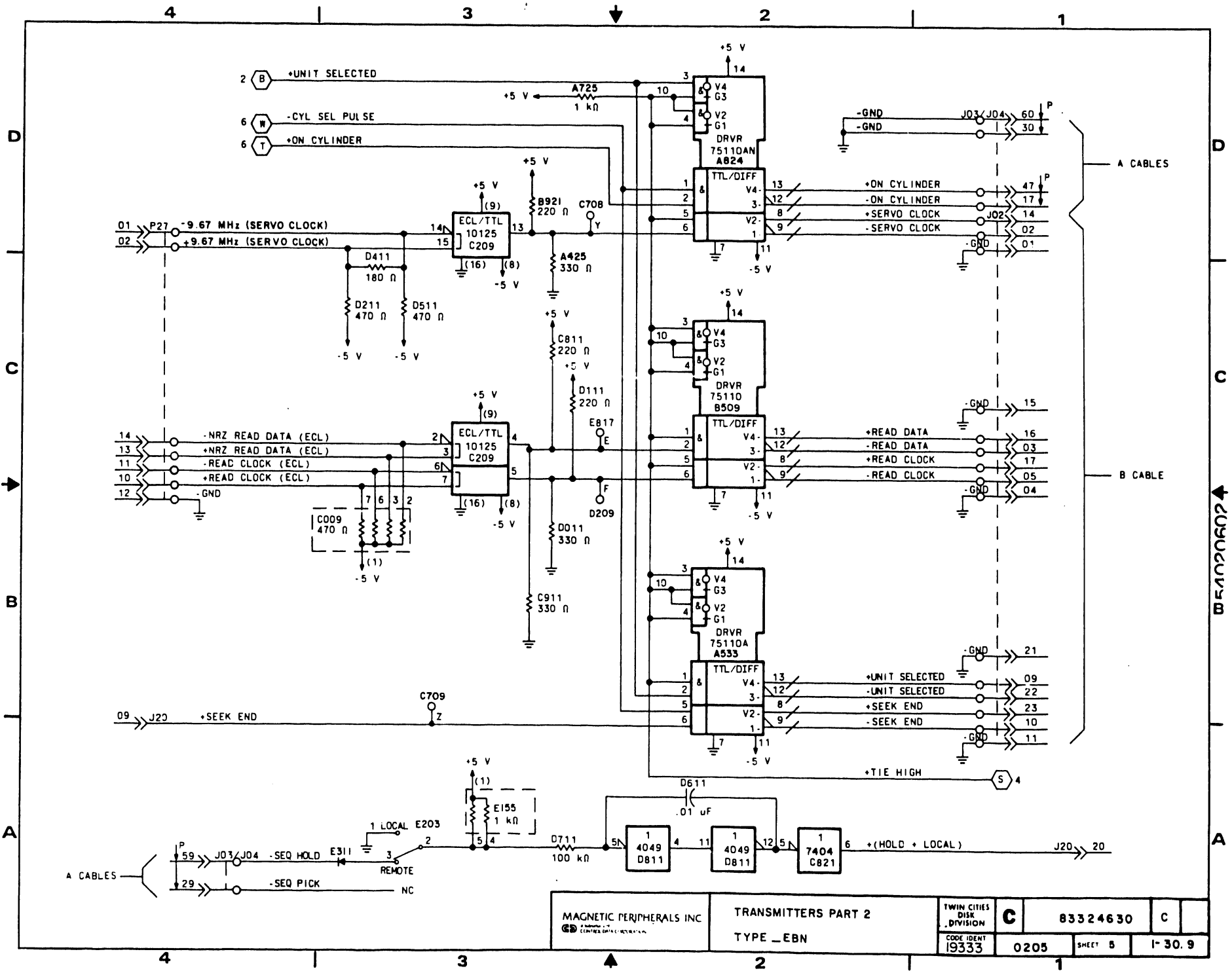

SIGNAL INPUTS

From Fan	01	>>	J48
0409 J14-31	22	>>	J20
0406 J14-08	25	>>	J20
0406 J14-09	23	>>	J20
0403 J14-29	18	>>	J20
0704 J27-08	08	>>	P27
0404 J14-21	02	>>	J20



SIGNAL OUTPUTS

J20	>>	26	0406 J14-33
J20	>>	03	0410 J14-19
J20	>>	06	0410 J14-23
P27	>>	09	0704 J27-09
P27	>>	07	0702 J27-07
J20	>>	12	0409 J14-26
P27	>>	06	0704 J27-06
P27	>>	04	0705 J27-04
P27	>>	03	0705 J27-03
J20	>>	28	0406 J14-34
J20	>>	39	0406 J14-01
J20	>>	37	0406 J14-02
J20	>>	35	0406 J14-03
J20	>>	33	0406 J14-04
J20	>>	31	0406 J14-05
J20	>>	38	0418 J14-39
J20	>>	40	0418 J14-40
J20	>>	10	0406 J14-25

LOGIC CROSS REFERENCE INFORMATION

PUB		83324630	REV	D
CROSS REF NO	0206	PAGE	1-30.10	

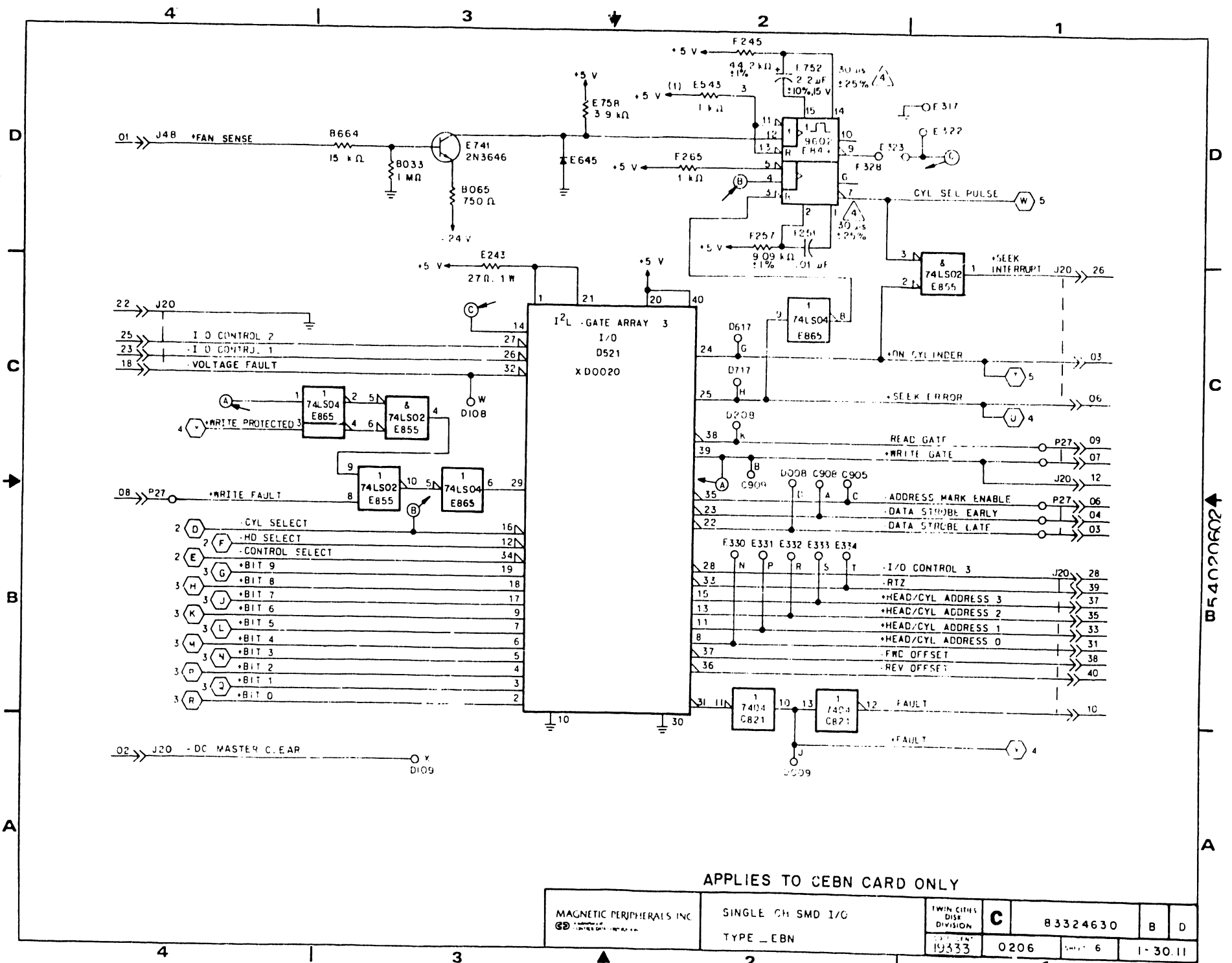

APPLIES TO CEBN CARD ONLY

MAGNETIC PERIPHERALS INC. <small>MEMBER OF THE DATA STORAGE GROUP</small>	SINGLE CH SMD 1/0 TYPE - EBN	TWIN CITIES DISK DIVISION	C	83324630	B	D
		19333				

SIGNAL INPUTS

From Fan	01	J48
0409 J14-31	22	J20
0406 J14-08	25	J20
0406 J14-09	23	J20
0403 J14-29	18	J20
0704 J27-08	08	P27
0404 J14-21	02	J20

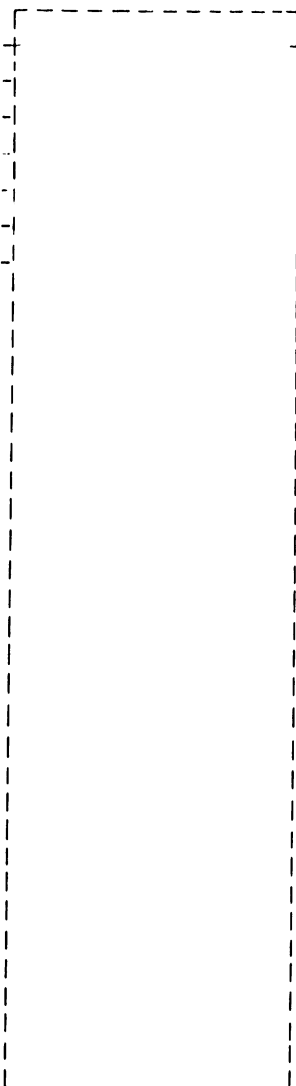

SIGNAL OUTPUTS

J20	26	0406	J14-33
J20	03	0410	J14-19
J20	06	0410	J14-23
P27	09	0704	J27-09
P27	07	0702	J27-07
J20	12	0409	J14-26
P27	06	0704	J27-06
P27	04	0705	J27-04
P27	03	0705	J27-03
J20	28	0406	J14-34
J20	39	0406	J14-01
J20	37	0406	J14-02
J20	35	0406	J14-03
J20	33	0406	J14-04
J20	31	0406	J14-05
J20	38	0418	J14-39
J20	40	0418	J14-40
J20	10	0406	J14-25

LOGIC CROSS REFERENCE INFORMATION

PUB	83324630	REV	D
CROSS REF NO	0206	PAGE	1-30.12

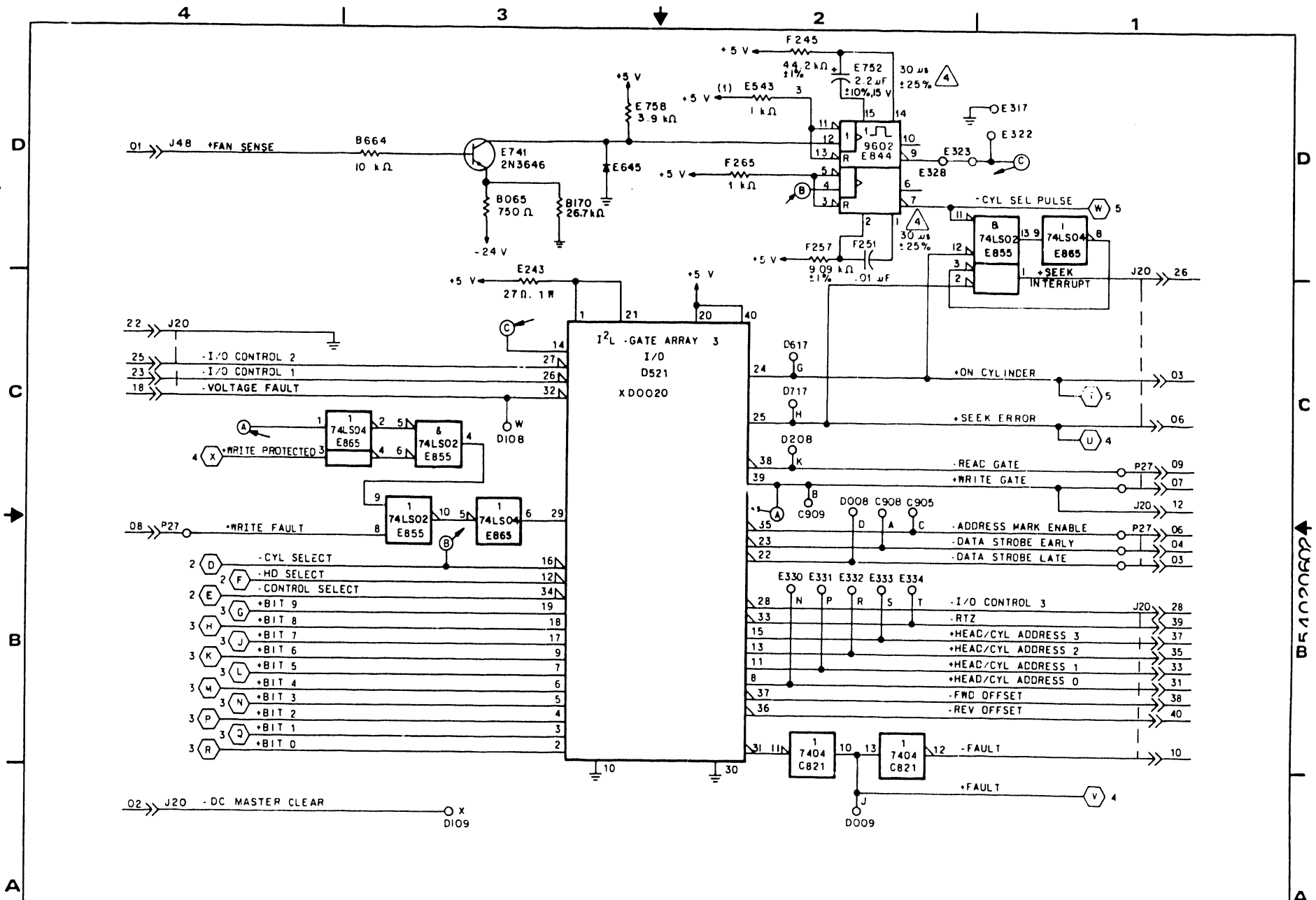

APPLIES TO ALL _EBN CARDS EXCEPT B/C/EBN.

MAGNETIC PERIPHERALS INC CORPORATION	SINGLE CH SMD I/O	TWIN CITIES DISK DIVISION	C	(13324630)	E
	TYPE _EBN	CODE IDENT 19333	0206	SHEET 6	1-30.13

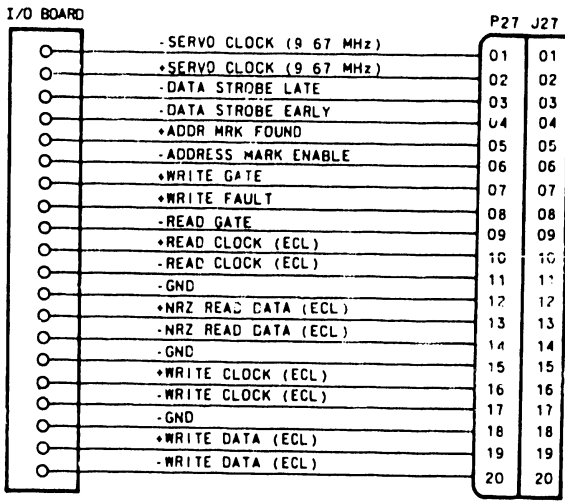
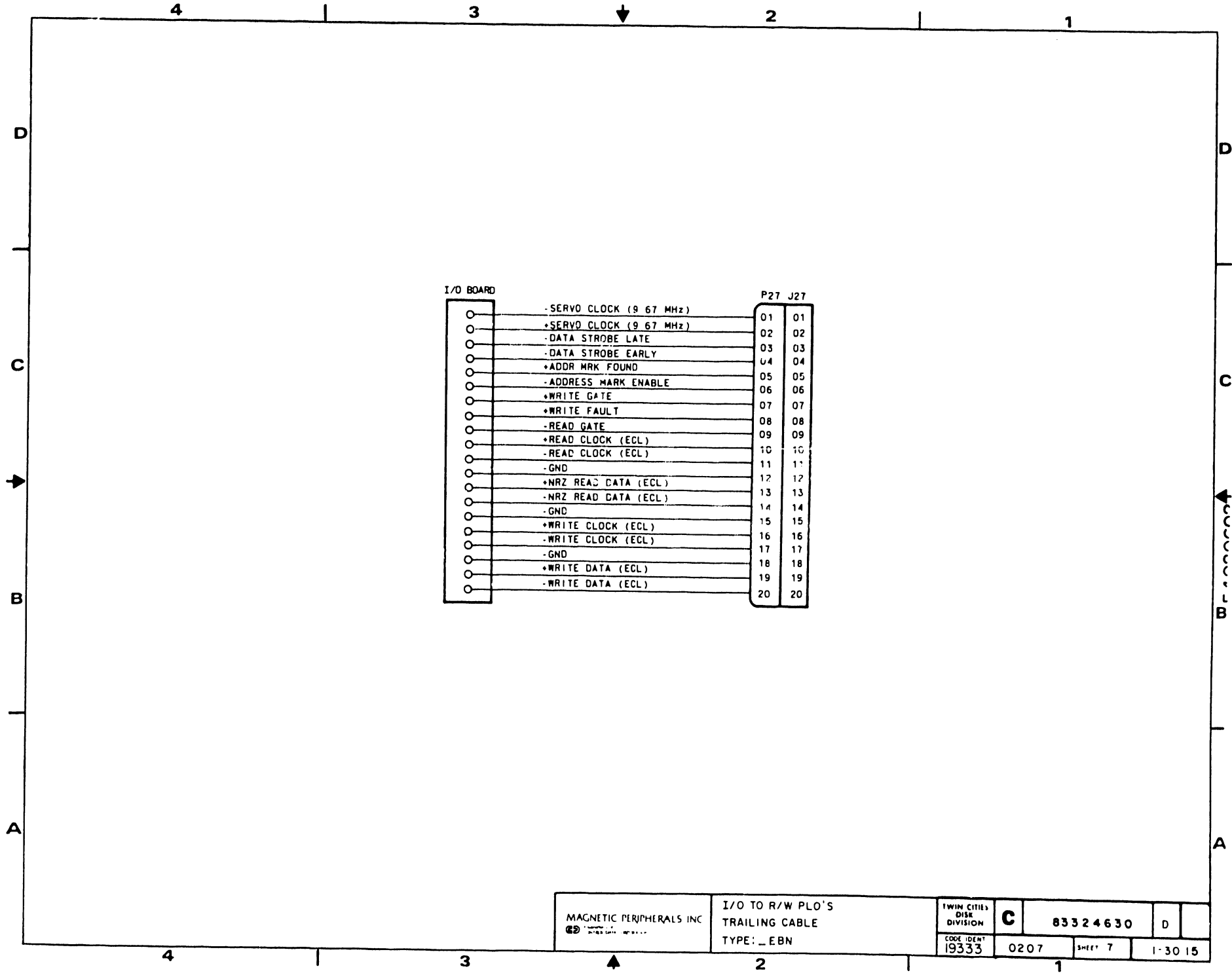

MAGNETIC PERIPHERALS INC 	I/O TO R/W PLO'S TRAILING CABLE TYPE: _ EBN	TWIN CITIES DISK DIVISION	C	83324630	D
		CODE IDENT 19333	0207	SHEET 7	1-30 15

SIGNAL INPUTS

1002	J40-11	05	>>	J19	-----
NC	-	07	>>	J19	-----
1002	J40-01	08	>>	J19	-----
1002	J40-02	03	>>	J19	-----
NC	-	04	>>	J19	-----
1002	J40-03	01	>>	J19	-----
1002	J40-15	06	>>	J19	-----
NC	-	02	>>	J19	-----

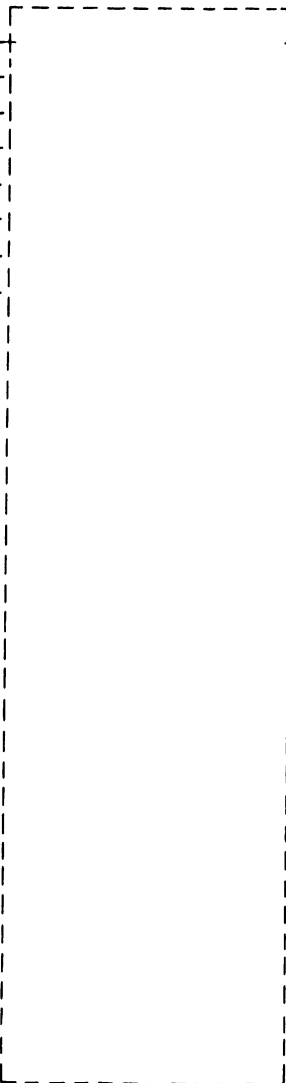

SIGNAL OUTPUTS

J44	>>	04	Head Alignment Test Jack
J44	>>	06	Head Alignment Test Jack
J44	>>	03	Head Alignment Test Jack
J44	>>	01	Head Alignment Test Jack
J44	>>	05	Head Alignment Test Jack

LOGIC CROSS REFERENCE INFORMATION

PUB		REV	
83324630		D	
CROSS REF NO	PAGE		
0201	1-30.16		

UNUSED LOGIC ELEMENTS		
ELEMENT	LOCATION	OUTPUT PINS
10125	C510	4
4049	K153	10, 12, 15

FILTER CAPS	
.1 μ F	
+5 V	-5 V
B710	A732
C920	B722
E111	D611
E264	D621
E732	E142
E821	E231
EB42	EB64
F453	F411
F931	F421
G022	G031
G064	G042
G642	G664
H253	J342
H732	
H764	
J938	
J944	
K653	
K764	

PART NO. RANGE	REVISION RECORD						
	REV	ECO	DESCRIPTION	DRFT	DATE	CHKD	APP
00 THRU 00	A	013300	RELEASED		3-4-83		CSH

1. UNLESS OTHERWISE SPECIFIED:
- ALL 16 PIN IC'S HAVE PIN 8 CONNECTED TO GROUND AND PIN 16 CONNECTED TO +5 V.
 - ALL 14 PIN IC'S HAVE PIN 7 CONNECTED TO GROUND AND PIN 14 CONNECTED TO +5 V.
 - ALL DICEES 15165580.
 - ALL TRANSISTORS, PNP, 2N3646, 50210310.
 - ALL RESISTOR PACK RESISTORS, 1/8 W, $\pm 3\%$.
 - ALL \bigcirc - \bigcirc INDICATES MOLDED JUMPER WIRES.

- $\triangle 2$ DELAY TIME FOR REFERENCE ONLY.
- $\triangle 3$ SEE TABLE FOR .1 μ F FILTER CAPACITOR LOCATIONS.
- $\triangle 4$ J05 AND J06 ARE A/B CABLE JUMPER.

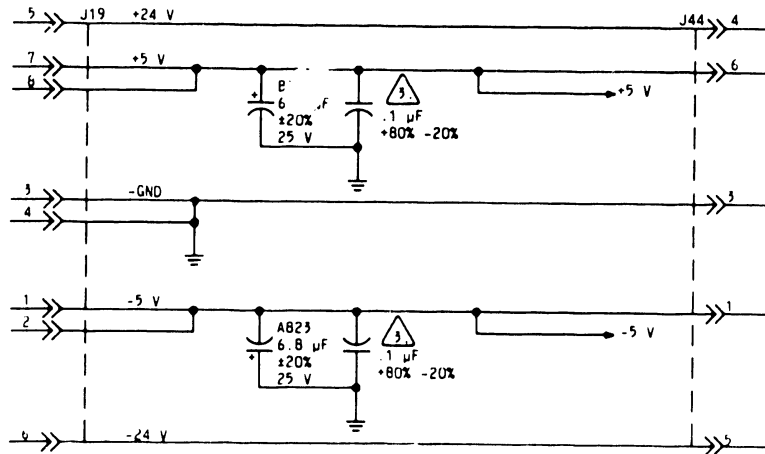

APPLIES TO DUAL CHANNEL UNITS ONLY.

REFERENCE DRAWING		MAGNETIC PERIPHERALS INC. a Control Data Company		TITLE	
COMP ASSY. 54021300		FIRST USED ON		SCHEMATIC DIAGRAM	
CTR. 54021500		NEXT ASSEMBLY		DUAL CH SMD I/O	
COMPONENTS EXCEPT AS NOTED		DWN F. A.		TYPE AEDN	
TOLERANCE	VALUE	RATING	CHKD	DATE	
RES	$\pm 5\%$	OHMS	1/4W	DG Donat	3-17-83
CAP	$\pm 10\%$			J. Heil	3-18-83
				MFG	7-27-83
				QA	7-27-83
TWIN CITIES DISK DIVISION			C 83324630 B		
FORM NO. 19333			0201 SHEET 1 OF 13 1-31		
REF 54021400			PRODUCT RSD/FSD		

W54021400

SIGNAL INPUTS

0405 J14-10 20 >> J20

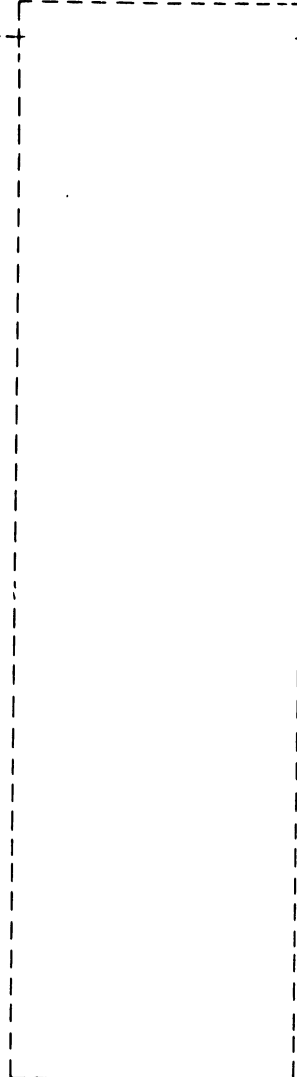

SIGNAL OUTPUTS

J20 >> 36	0405 J14-18
J20 >> 34	0405 J14-17
J20 >> 30	0405 J14-15
J20 >> 28	0405 J14-14
J20 >> 26	0405 J14-13
J20 >> 22	0405 J14-11

LOGIC CROSS REFERENCE INFORMATION

PUB		REV	
83324630		B	
CROSS REF NO	PAGE		
0202	1-32		

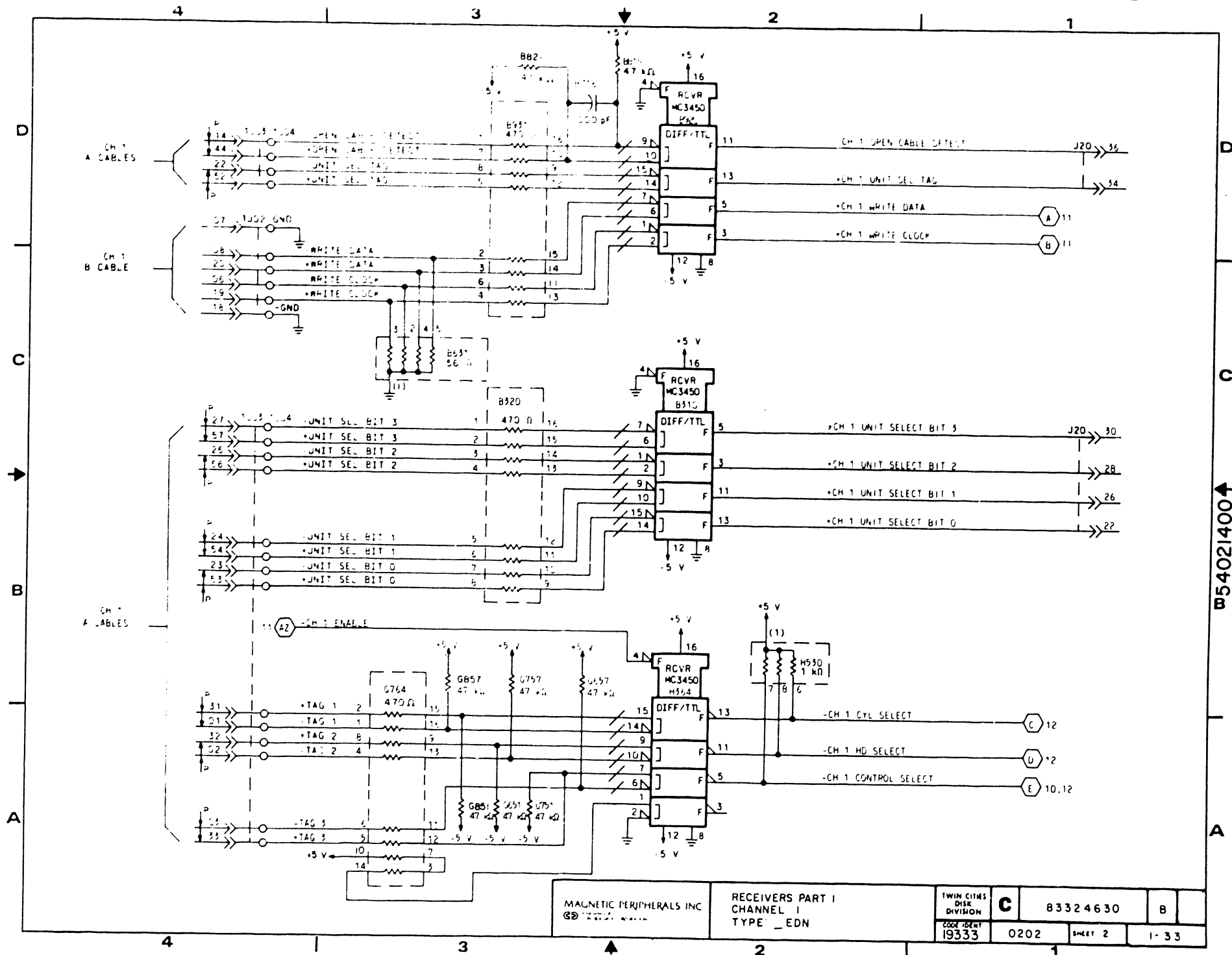

MAGNETIC PERIPHERALS INC
 6500 ...

RECEIVERS PART I
 CHANNEL 1
 TYPE - EDN

TWIN CITIES DISK DIVISION	C	83324630	B
CODE IDENT	19333	0202	SHEET 2
			1-33

B54021400

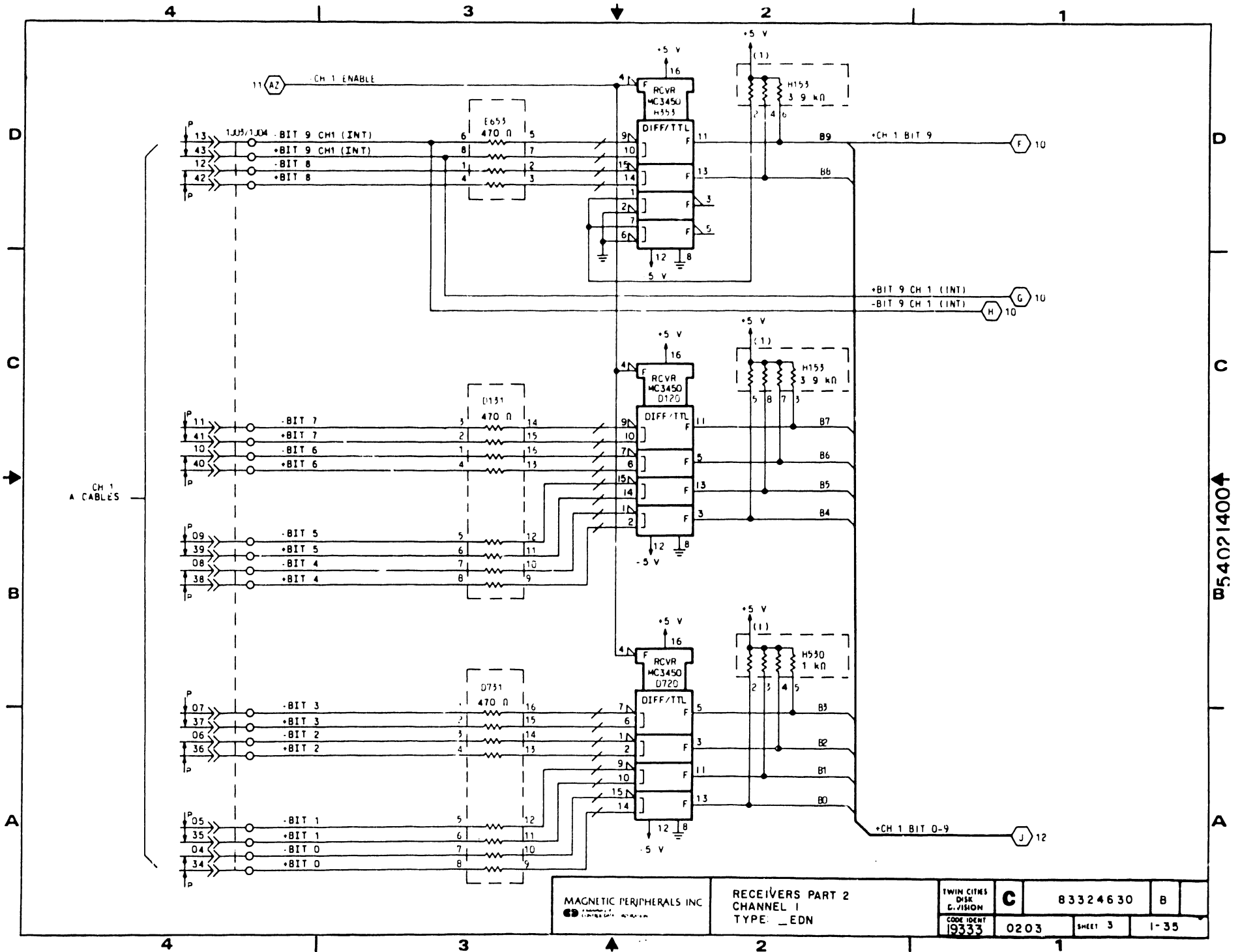

B540214004

MAGNETIC PERIPHERALS INC <small>ESTABLISHED 1961</small>	RECEIVERS PART 2 CHANNEL 1 TYPE: EDN		TWIN CITIES DISK DIVISION	C	83324630	B
	CODE IDENT 19333	0203	SHEET 3	1-35		

SIGNAL INPUTS

0410	J14-20	40	>>>	J20
0410	J14-35	11	>>>	J20
0705	J27-05	05	>>>	P27
0406	J14-12	24	>>>	J20
0405	J14-22	37	>>>	J20
0409	J14-24	33	>>>	J20

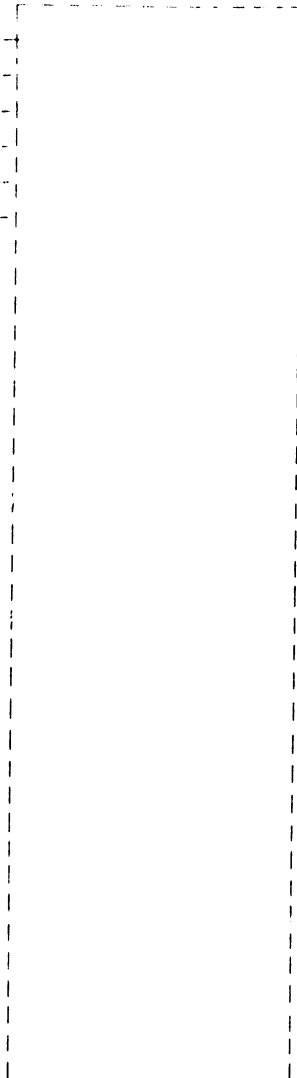

SIGNAL OUTPUTS

LOGIC CROSS REFERENCE INFORMATION

PUB		REV	
83324630		B	
CROSS REF NO	PAGE		
0204	1-36		

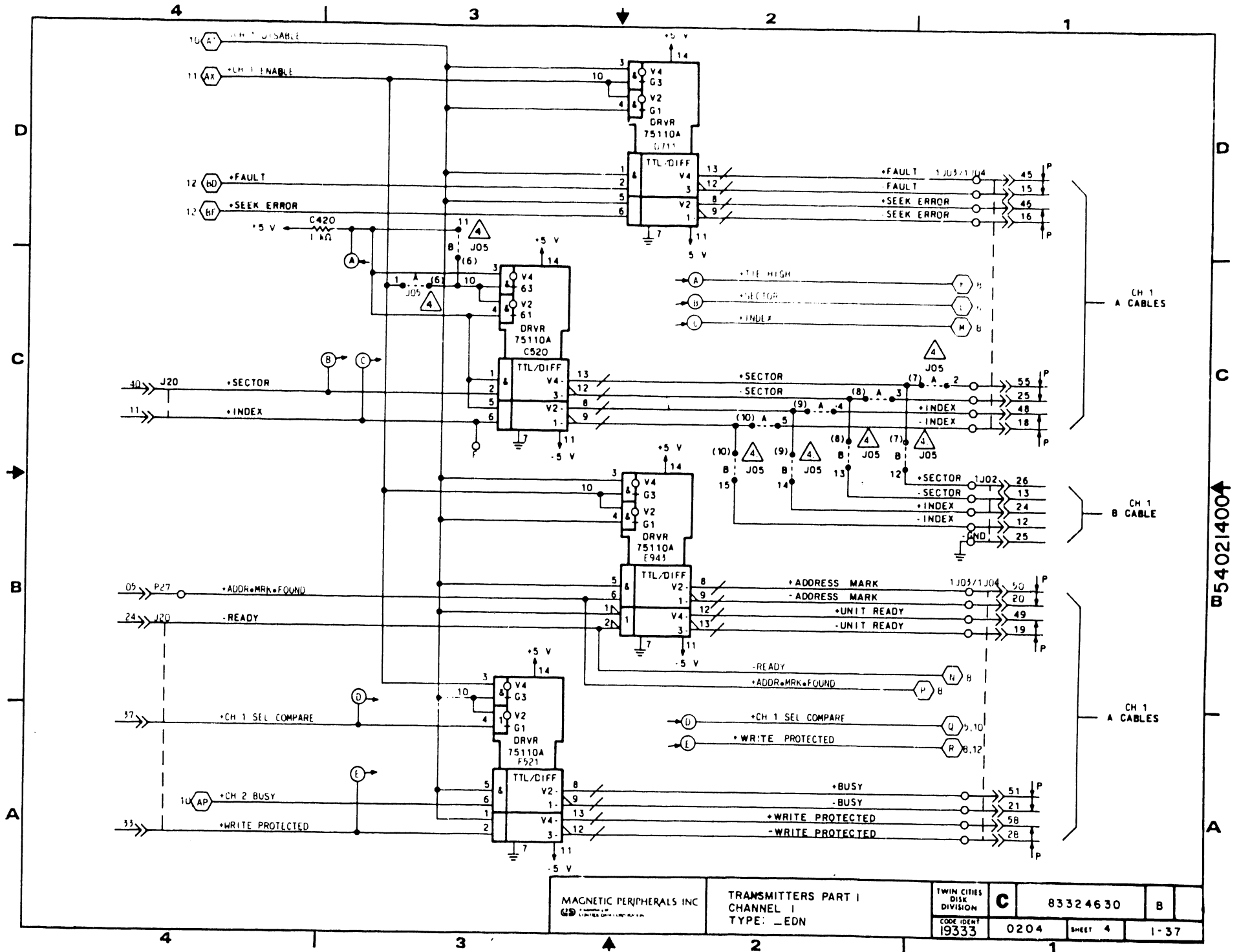

MAGNETIC PERIPHERALS INC
3000 W. 100th St. Minneapolis, MN 55425

TRANSMITTERS PART I
 CHANNEL 1
 TYPE: EDN

TWIN CITIES DISK DIVISION	C	83324630	B
CODE IDENT 19333	0204	SHEET 4	1-37

B54021400A

SIGNAL INPUTS

0703	J27-01	01	>>	P27
0703	J27-02	02	>>	P27
0702	J27-14	14	>>	P27
0702	J27-13	13	>>	P27
0702	J27-11	11	>>	P27
0702	J27-10	10	>>	P27
0701	J27-12	12	>>	P27

SIGNAL OUTPUTS

J20 >> 21 0407 J14-30

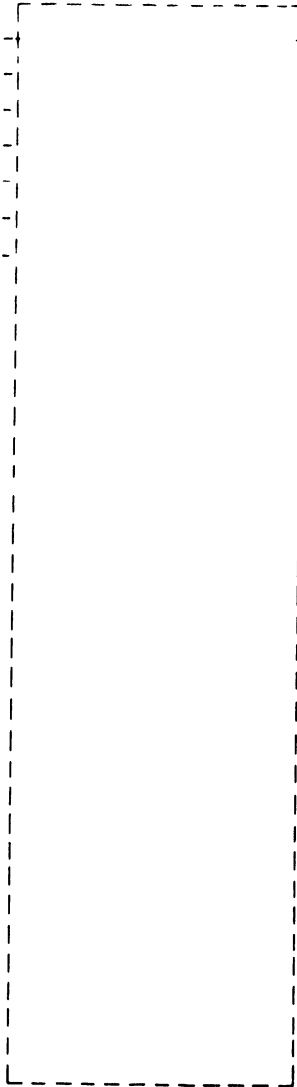

LOGIC CROSS REFERENCE INFORMATION

PUB		REV	
83324630		B	
CROSS REF NO	0205	PAGE	1-38

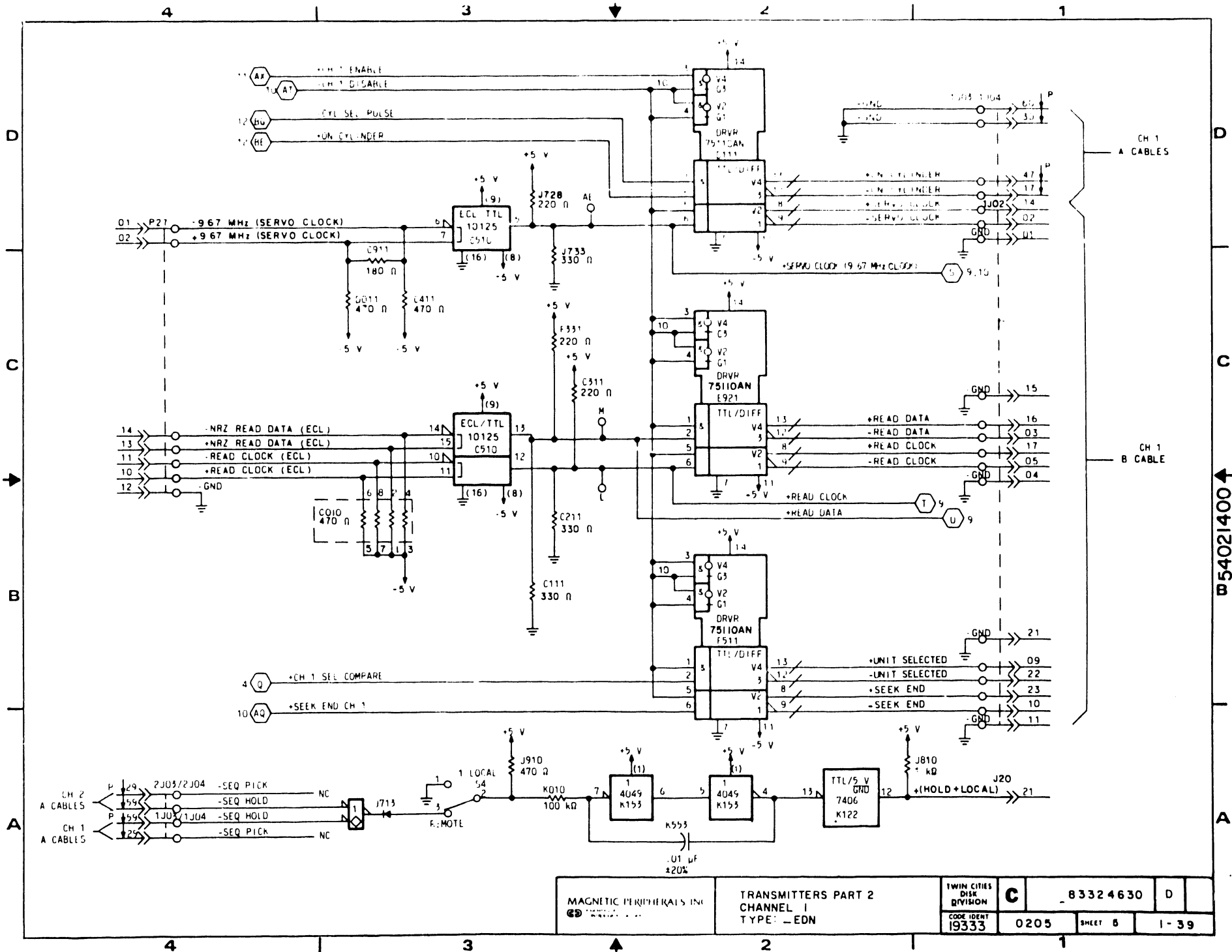

B 54021400

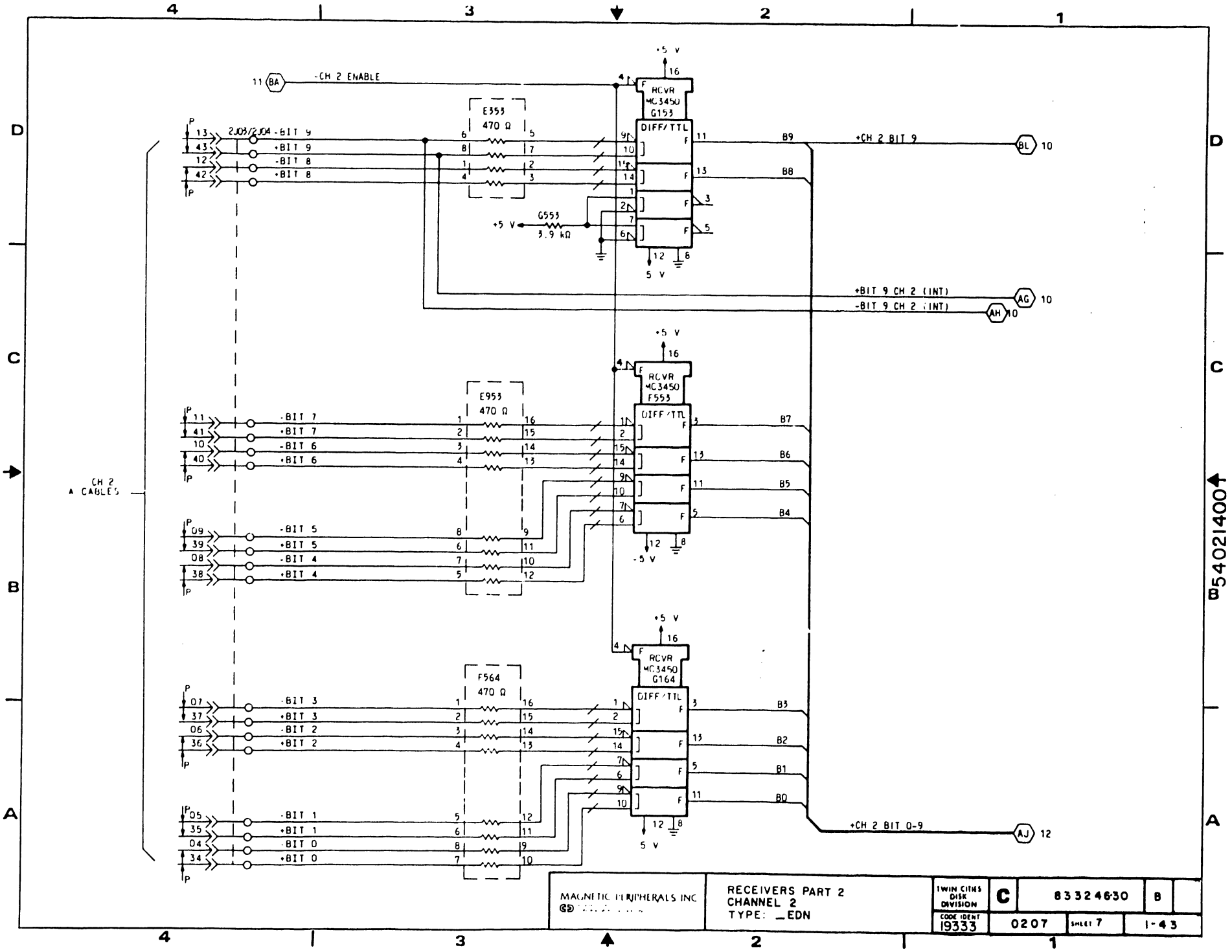

B54021400↑

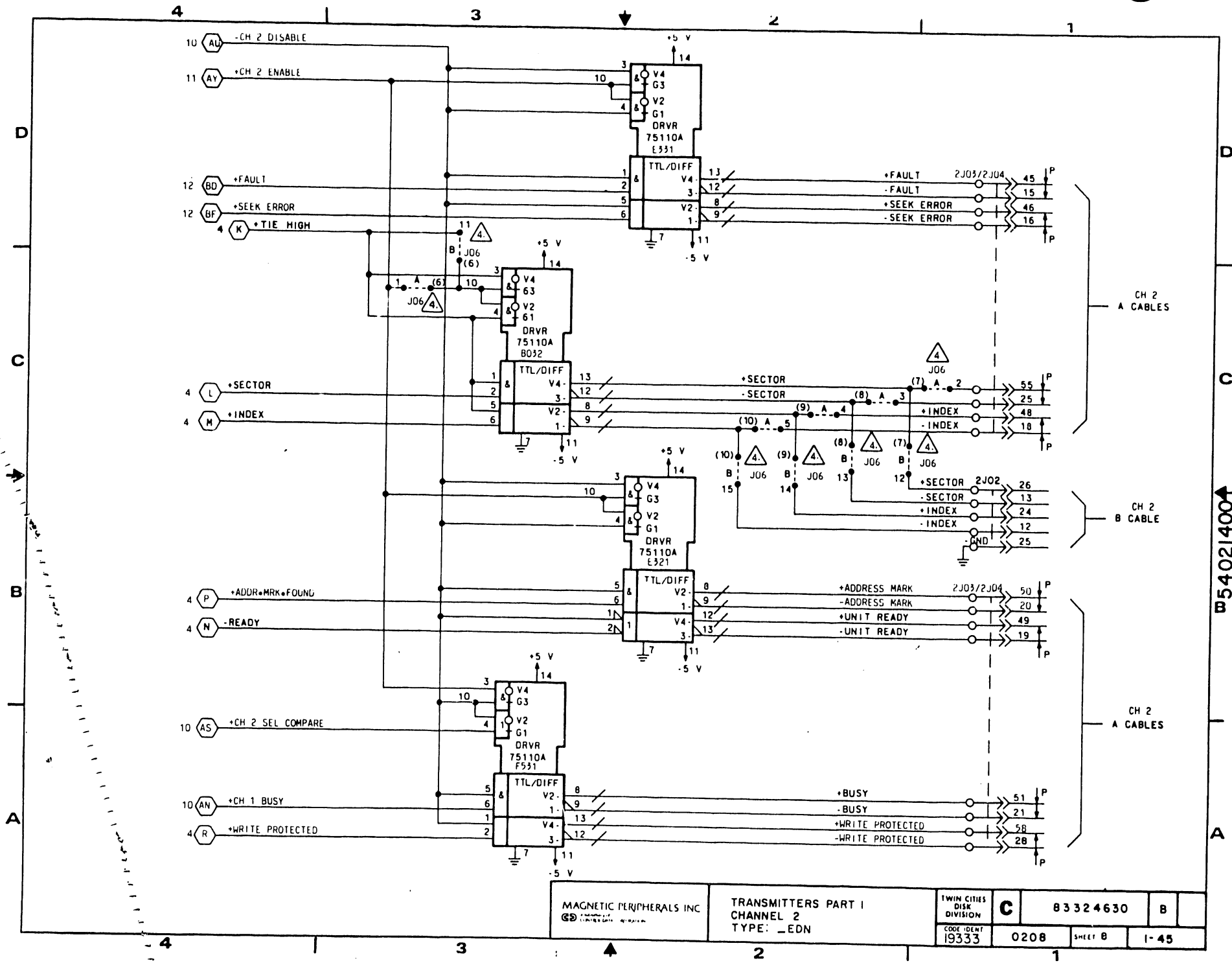

MAGNETIC PERIPHERALS INC G3	TRANSMITTERS PART I CHANNEL 2 TYPE: _EDN	TWIN CITIES DISK DIVISION	C	83324630	B
		CODE IDENT 19333			

B54021400A

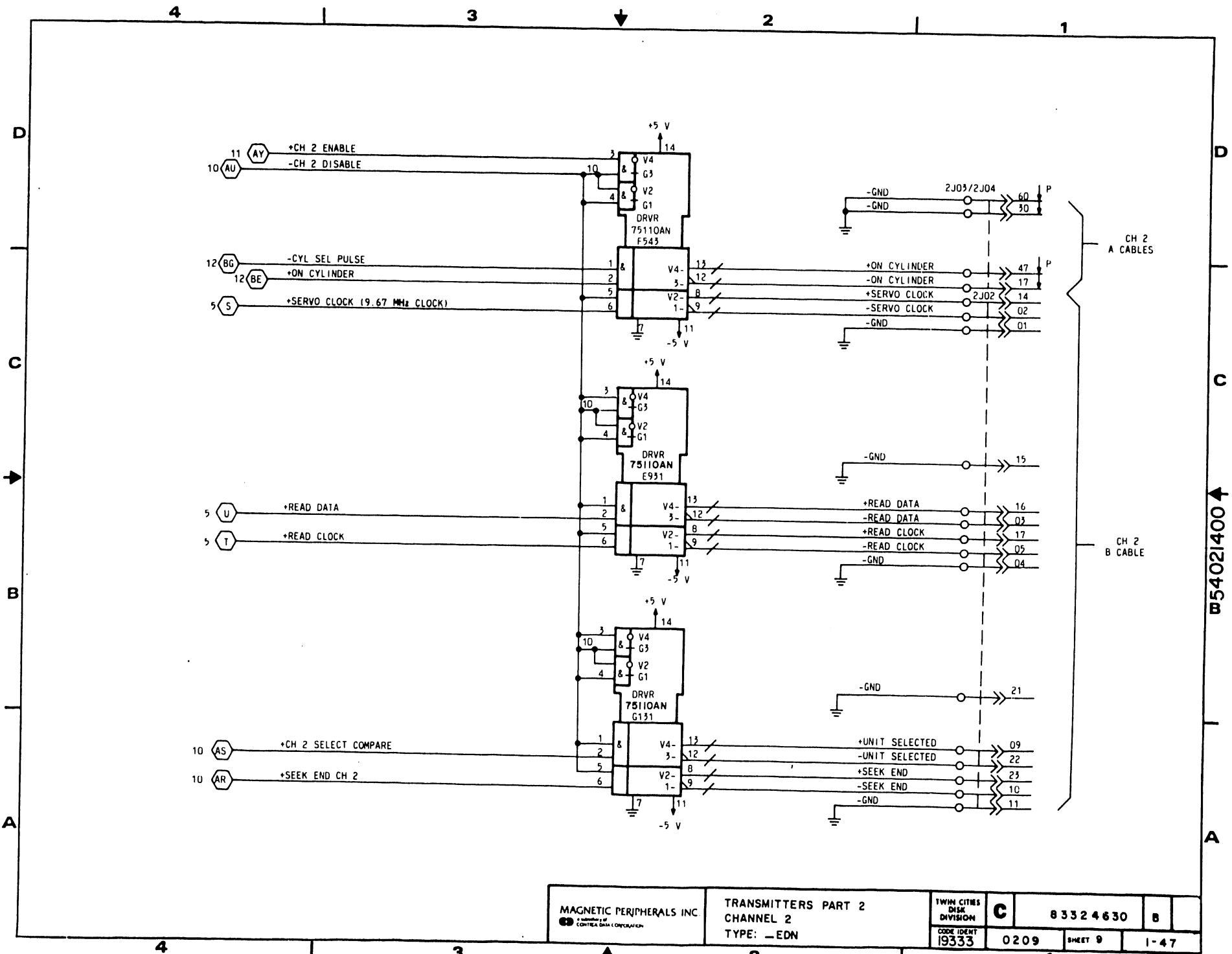

MAGNETIC PERIPHERALS INC
a subsidiary of
 CONTECH DATA CORPORATION

TRANSMITTERS PART 2
 CHANNEL 2
 TYPE: -EDN

TWIN CITIES DISK DIVISION	C	83324630	B
CODE IDENT 19333	0209	SHEET 9	1-47

W54021400

SIGNAL INPUTS

0404 J14-21 -39-->> J20
0405 J14-32 -17-->> J20
0405 J14-07 -14-->> J20
0405 J14-06 -12-->> J20
0410 J14-16 -32-->> J20

SIGNAL OUTPUTS

J20 -->> 20 0405 J14-10

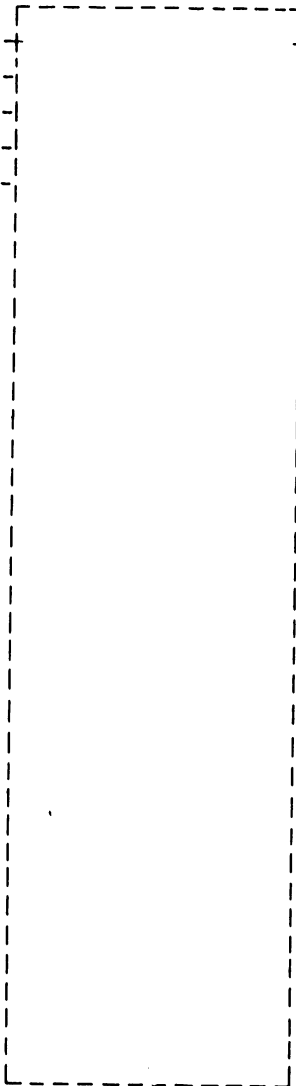

LOGIC CROSS REFERENCE INFORMATION

PUB		REV	
83324630		B	
CROSS REF NO	PAGE		
0210	1-48		

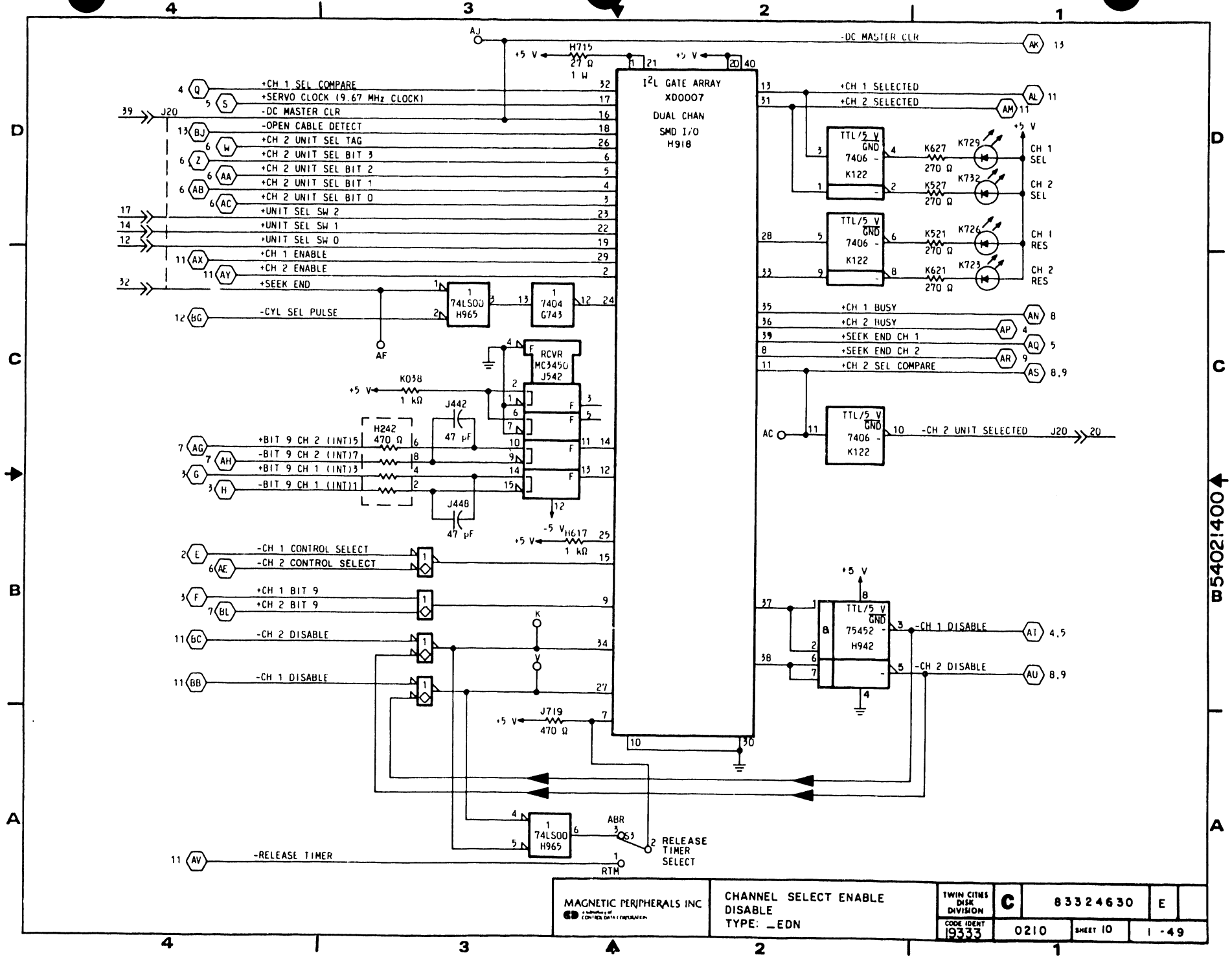

- 4 (Q) +CH 1 SEL COMPARE 32
- 5 (S) +SERVO CLOCK (9.67 MHz CLOCK) 17
- 39 (J20) -DC MASTER CLR 16
- 13 (BJ) -OPEN CABLE DETECT 18
- 6 (W) +CH 2 UNIT SEL TAG 26
- 6 (Z) +CH 2 UNIT SEL BIT 3 6
- 6 (AA) +CH 2 UNIT SEL BIT 2 5
- 6 (AB) +CH 2 UNIT SEL BIT 1 4
- 6 (AC) +CH 2 UNIT SEL BIT 0 3
- 17 +UNIT SEL SW 2 23
- 14 +UNIT SEL SW 1 22
- 12 +UNIT SEL SW 0 19
- 11 (AX) +CH 1 ENABLE 29
- 11 (AY) +CH 2 ENABLE 2
- 32 +SEEK END

- 12 (BG) -CYL SEL PULSE
- 7 (AG) +BIT 9 CH 2 (INT)15
- 7 (AH) -BIT 9 CH 2 (INT)17
- 3 (G) +BIT 9 CH 1 (INT)13
- 3 (H) -BIT 9 CH 1 (INT)11
- 2 (E) -CH 1 CONTROL SELECT
- 6 (AE) -CH 2 CONTROL SELECT
- 3 (F) +CH 1 BIT 9
- 7 (BL) +CH 2 BIT 9
- 11 (BC) -CH 2 DISABLE
- 11 (BB) -CH 1 DISABLE

- 11 (AV) -RELEASE TIMER
- 1 (ABR) RELEASE TIMER SELECT
- 1 (RTM)

- 13 +CH 1 SELECTED
- 31 +CH 2 SELECTED
- 28 +CH 1 RES
- 33 +CH 2 RES
- 35 +CH 1 BUSY
- 36 +CH 2 BUSY
- 39 +SEEK END CH 1
- 8 +SEEK END CH 2
- 11 +CH 2 SEL COMPARE

- AC -CH 2 UNIT SELECTED J20 20
- 37 -CH 1 DISABLE 4.5
- 38 -CH 2 DISABLE 8.9

MAGNETIC PERIPHERALS INC A Division of General Electric Corporation	CHANNEL SELECT ENABLE DISABLE TYPE: _EDN		TWIN CITIES DISK DIVISION	C	83324630	E
	CODE IDENT 19333	0210	SHEET 10			

W54021400A

SIGNAL INPUTS

SIGNAL OUTPUTS

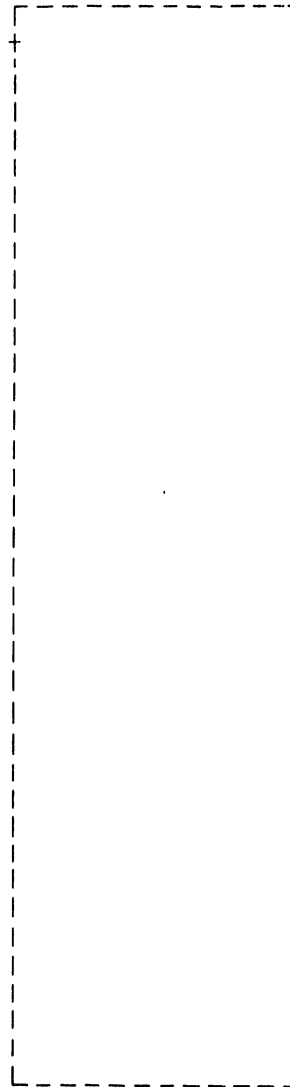

P27	>>	18	0701	J27-18
P27	>>	20	0702	J27-20
P27	>>	19	0702	J27-19
P27	>>	17	0702	J27-17
P27	>>	16	0702	J27-16
P27	>>	15	0701	J27-15

LOGIC CROSS REFERENCE INFORMATION

PUB	83324630	REV	B
CROSS REF NO	0211	PAGE	1-50

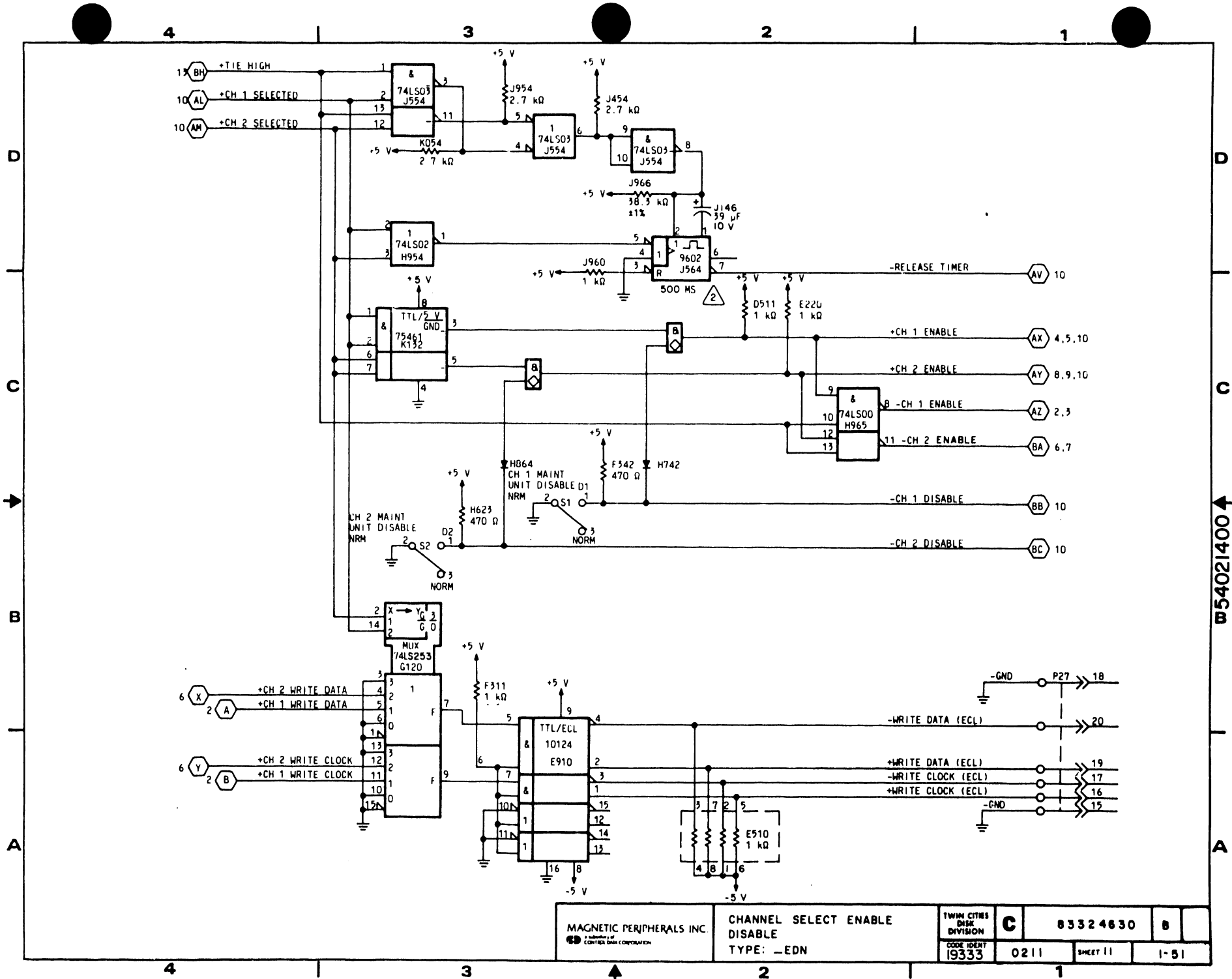

B54021400

MAGNETIC PERIPHERALS INC. <small>a subsidiary of</small> <small>CONTROL DATA CORPORATION</small>	CHANNEL SELECT ENABLE DISABLE TYPE: -EDN		TWIN CITIES DISK DIVISION	C	83324630	B
	CODE IDENT 19333	0211	SHEET 11	1-51		

SIGNAL INPUTS

0704	J27-08	08	>> P27
0409	J14-31	19	>> J20
0406	J14-08	16	>> J20
0406	J14-09	18	>> J20
0403	J14-29	23	>> J20

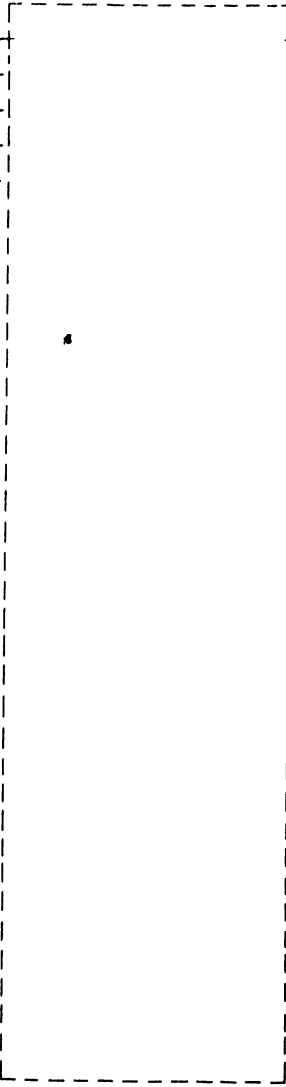

SIGNAL OUTPUTS

P27	>> 07	0702	J27-07
J20	>> 29	0409	J14-26
P27	>> 09	0704	J27-09
P27	>> 06	0704	J27-06
P27	>> 04	0705	J27-04
P27	>> 03	0705	J27-03
J20	>> 04	0406	J14-02
J20	>> 06	0406	J14-03
J20	>> 08	0406	J14-04
J20	>> 10	0406	J14-05
J20	>> 13	0406	J14-34
J20	>> 03	0418	J14-39
J20	>> 01	0418	J14-40
J20	>> 02	0406	J14-01
J20	>> 31	0406	J14-25
J20	>> 38	0410	J14-19
J20	>> 35	0410	J14-23
J20	>> 15	0406	J14-33

LOGIC CROSS REFERENCE INFORMATION

PUB		REV
83324630		B
CROSS REF NO	PAGE	
0212	1-52	

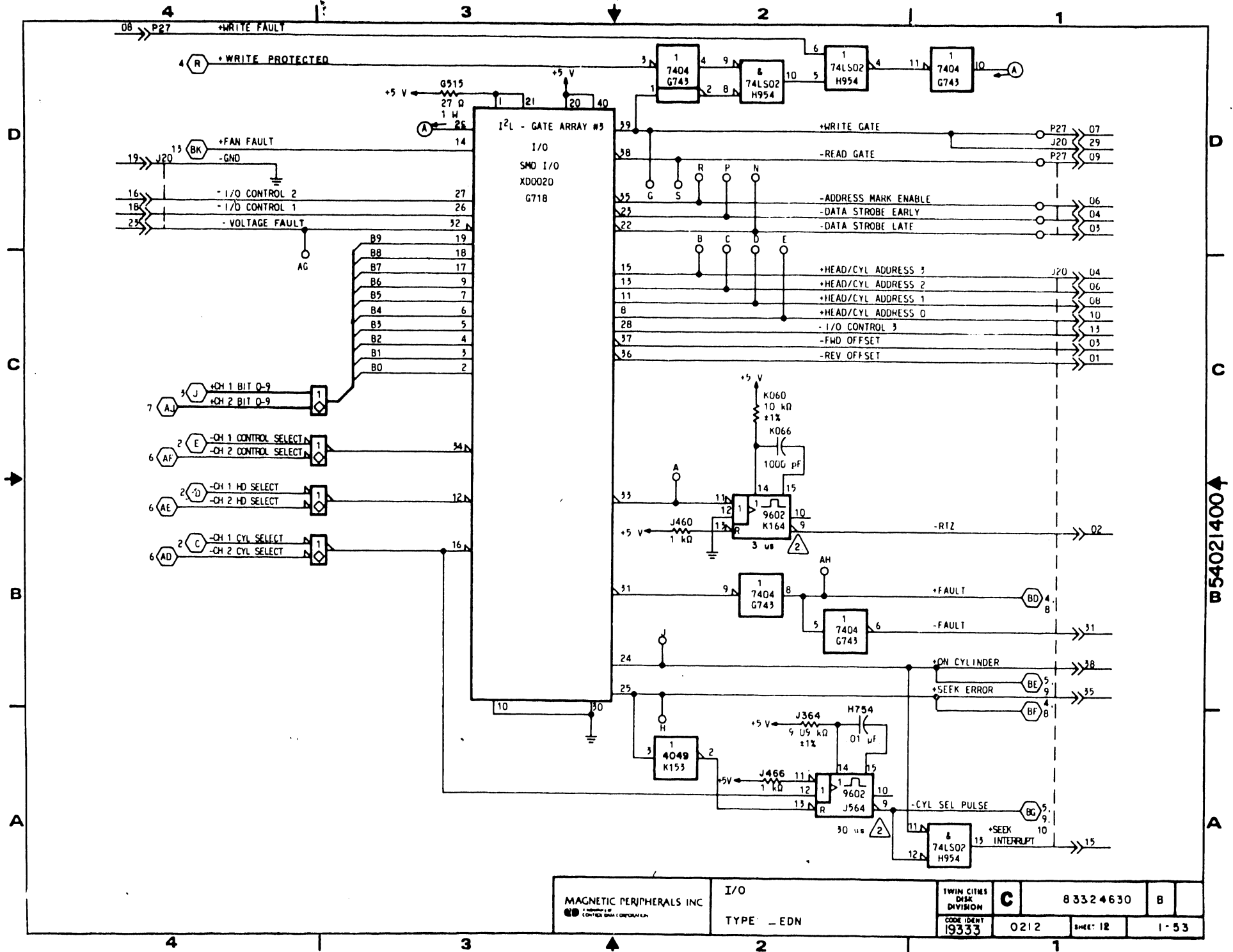

MAGNETIC PERIPHERALS INC A DIVISION OF CONTRACT DATA CORPORATION	I/O	TWIN CITIES DISK DIVISION	C	83324630	B
	TYPE - EDN	CODE IDENT 19333	0212	SHEET 12	1-53

B 54021400A

SIGNAL INPUTS

From Fan 01 --> J48
From Fan 02 --> J48
From Fan 03 --> J48
From Fan 04 --> J48

SIGNAL OUTPUTS

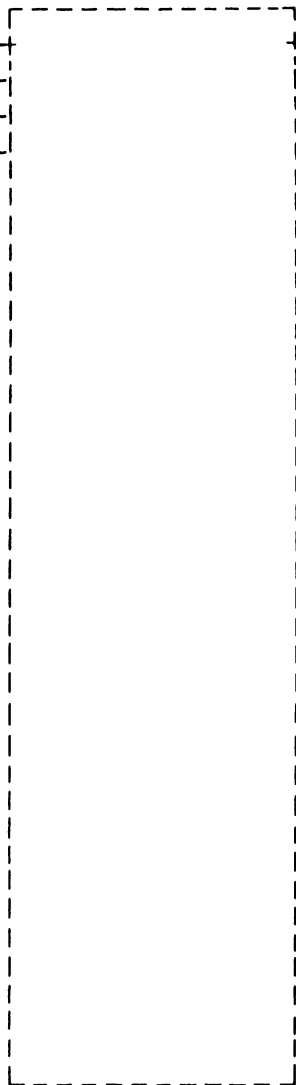

LOGIC CROSS REFERENCE INFORMATION

PUB	83324630	REV	B
CROSS REF NO	0213	PAGE	1-54

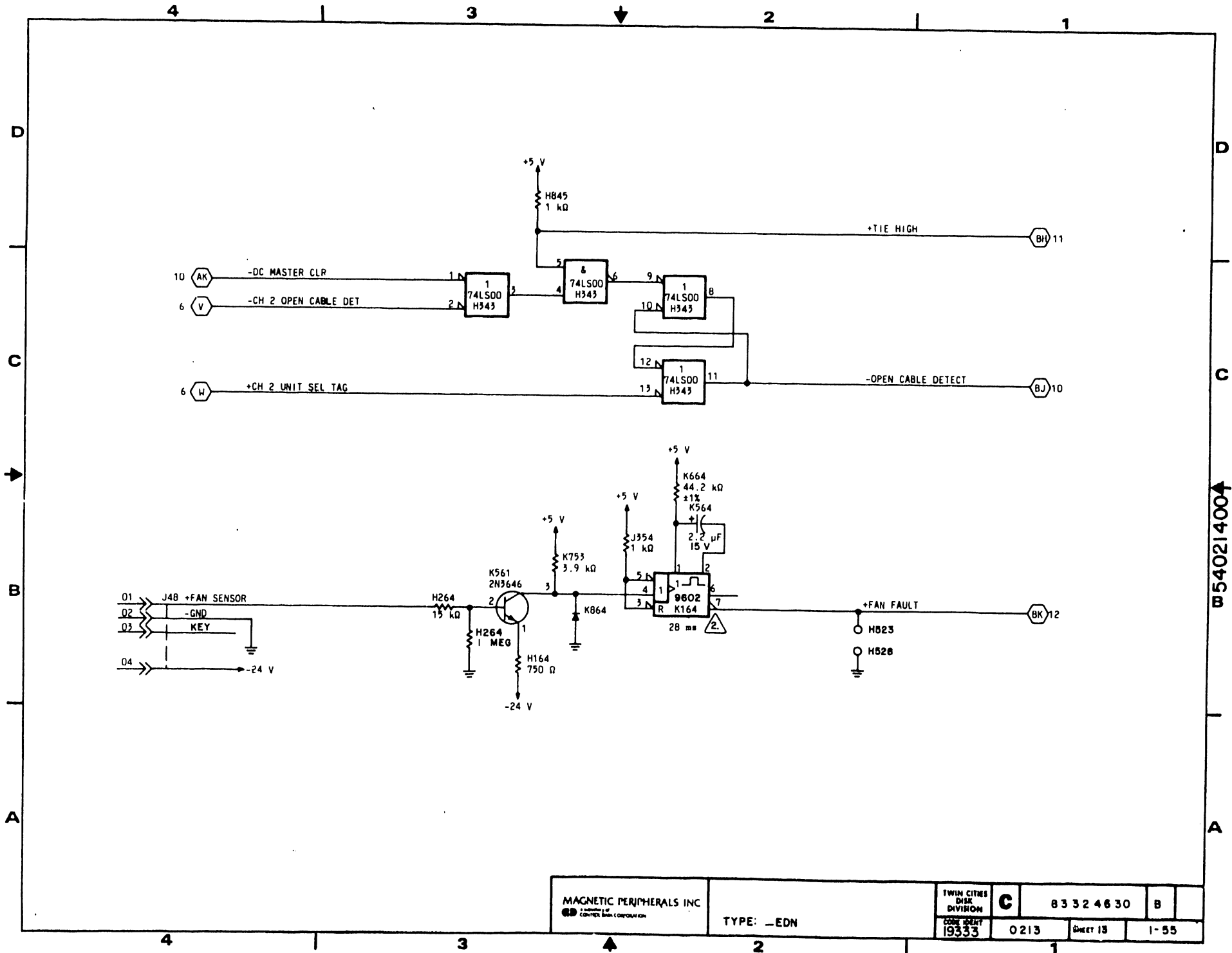

B54021400A

MAGNETIC PERIPHERALS INC <small>a subsidiary of CONTROL DATA CORPORATION</small>	TYPE: -EDN		TWIN CITIES DISK DIVISION	C	83 32 46 30	B
	CODE IDENT 19333	0213	SHEET 15	1-55		

SIGNAL INPUTS

0411 J28-01 -01-->-J34
0411 J28-03 -03-->-J34
0411 J28-05 -05-->-J34
0402 J28-06 -06-->-J34

SIGNAL OUTPUTS

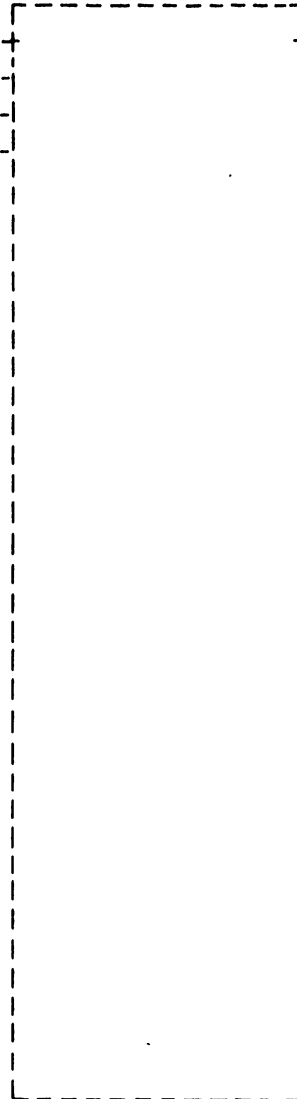

LOGIC CROSS REFERENCE INFORMATION

PUB	83324630	REV	D
CROSS REF NO	0301	PAGE	1-56

PART NO RANGE	REVISION RECORD						
	REV	ECO	DESCRIPTION	DRFT	DATE	CHKD	APP
00 THRU 99	01	D703018A	PNE-RELEASED		4/29/72	DL	III
	02	D703091	ADD CAP	DLM	7-29-72	DLD	II
	A	D703092	RELEASED	DLM	8-18-72	DFD	III
	B	D703352	ADD KEY	MJ	10-10-72		
	C	D703443	CORRECTION	MJ	10-10-72		

NOTES:
 I. UNLESS OTHERWISE SPECIFIED:

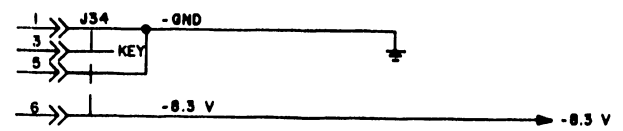

REFERENCE DRAWING			MAGNETIC PERIPHERALS INC.			TITLE		
COMP ASSY 54007301			FIRST USED ON			SCHEMATIC DIAGRAM SERVO PREAMP (RSD) TYPE BUUN		
CTR 54007501			NEXT ASSEMBLY					
COMPONENTS, EXCEPT AS NOTED			DWN	DL MEYER	2/29/71	SMALL DISK DIVISION	SIZE C	83324630
TOLERANCE	VALUE	RATING	CHKD	DG Donat	5/15/72			
RES			ENGR	R. Nielsen	9/13/72	D	SHEET 1 of 2	PAGE 1-57
CAP			MFG					
			QA	M. Beck	7/26/72	FORM NO. 19333	0301	REF: 54007401

SIGNAL INPUTS

SIGNAL OUTPUTS

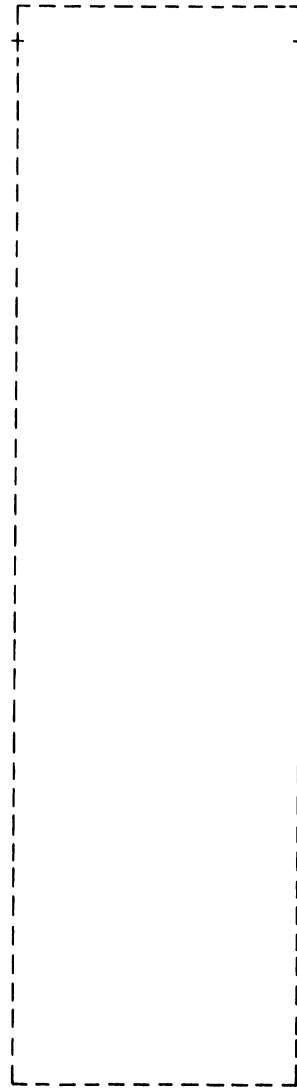

J34 >> 02 0411 J28-02
J34 >> 04 0411 J28-04

LOGIC CROSS REFERENCE INFORMATION

PUB 83324630		REV D
CROSS REF NO 0302	PAGE 1-58	

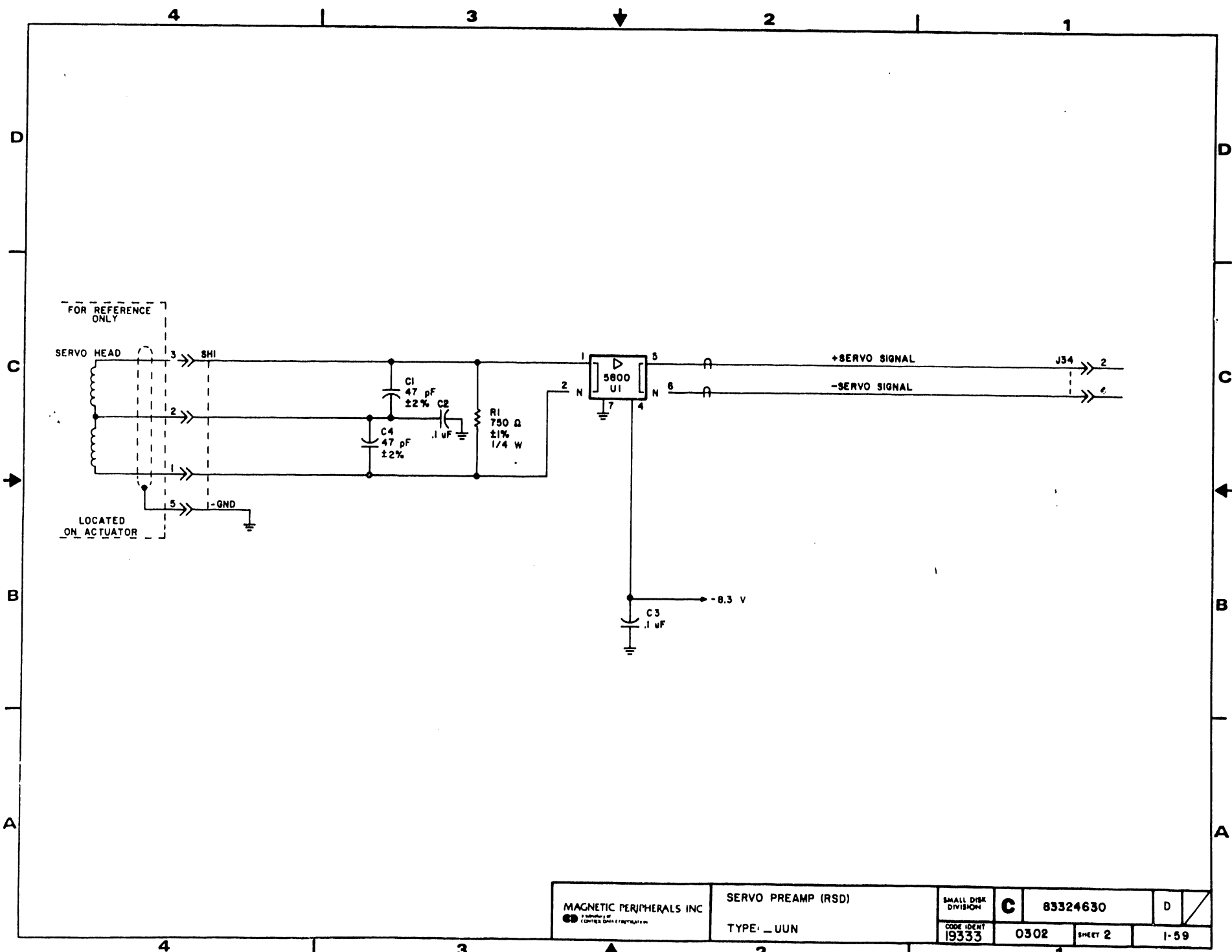

MAGNETIC PERIPHERALS INC <small>10000 WILSON BLVD CHICAGO, ILL. 60642</small>	SERVO PREAMP (RSD)	SMALL DISK DIVISION	C	83324630	D
	TYPE: UUN	CODE IDENT 19333	0302	SHEET 2	1-59

SIGNAL INPUTS

1002	J40-11	05	->>-	J21
1002	J40-04	07	->>-	J21
1002	J40-01	08	->>-	J21
1002	J40-02	03	->>-	J21
1002	J40-05	04	->>-	J21
1002	J40-03	01	->>-	J21
1002	J40-06	02	->>-	J21
1002	J40-15	06	->>-	J21

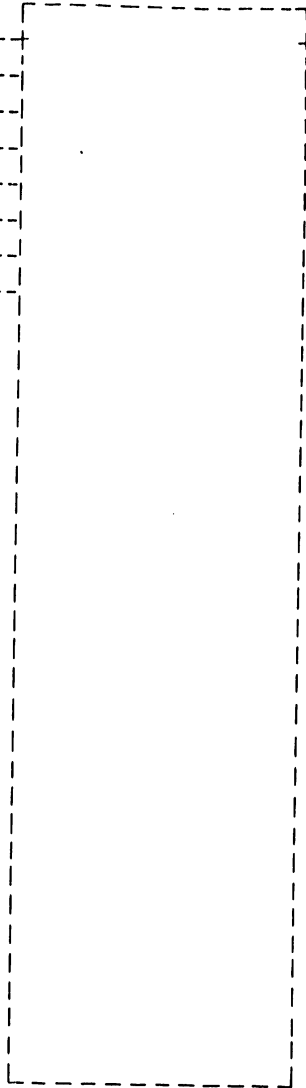
SIGNAL OUTPUTS**LOGIC CROSS REFERENCE INFORMATION**

PUB		83324630	REV	B
CROSS REF NO	0401	PAGE	1-60	

UNUSED LOGIC ELEMENTS		
ELEMENT	LOCATION	OUTPUT PINS
10102	P127	14
LM393	M782	7
10125	E715	5, 12, 13
74LS86	E235	3, 8, 11
13202	E672	10
LM339	E662	1, 2
74LS20	E851	8
74LS00	L918	11
96LS02	L208	9, 10
7406	E224	8, 12
412	C982	7

UNUSED TRANSISTOR PACKS		
TYPE	LOCATION	PINS
MPQ3546	N356	5, 6, 7

UNUSED RESISTOR PACKS		
VALUE	LOCATION	PIN(S)
1 kΩ	N505	2, 8
1 kΩ	K213	2, 5

PART NO RANGE		REVISION RECORD					
REV	ECO	DESCRIPTION	DRFT	DATE	CHRD	APP	
00	THRU 99						
01	0030230	PRC -RELEASED		7/1/82	060	III	
02	003079	ADD CAP	ULM	11/1/82	060	II	
03	003090	CHG SHT 9	ULM	7/24/82	060	II	
A	0333550	RELEASED	ULM	9/12/82	060	III	
B	0333110	CHG VALUES	ULM	10/15/82	060	II	
C	003213	CORRECTION	MJ	3-17-83			
D	003283	CHANGF COMPONENTS	MJ	3-17-83			
E	003288	CORRECTIONS	MJ	5-12-83			
F	003333	CORRECTIONS	MJ	7-14-83			
G	003330	CHANGE DIODE	MJ	1-14-83			
H	003429	CHANGE RES AND CAP	MJ	10-14-83			

FILTER CAPS			
.1 uF			
+5 V	-5 V	+15 V	-15 V
J538	F115	C881	L556
E116	N008		K664
E615	M337	F681	N675
E625		H281	M868
E734	P520	J281	J762
E743	M527	K181	G174
E752	N027	M681	EO62
G438	N827	N781	B462
G618	P527	M468	C481
H638	N737	P562	
H515		B981	
J262		D155	
L050			
L737			
K252			
L827			
L814			
K229			
J911			
K710			
P008			
M408			
H320			
B562			

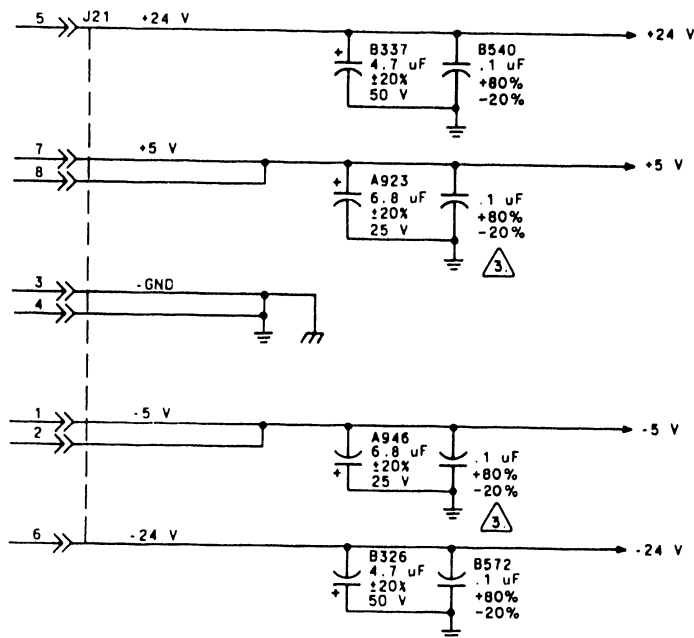

NOTES:

- UNLESS OTHERWISE SPECIFIED:
ALL 14 PIN IC'S HAVE PIN 7 CONNECTED TO GROUND.
ALL 16 PIN IC'S HAVE PIN 8 CONNECTED TO GROUND,
AND PIN 16 CONNECTED TO +5 V.
ALL DIODES, 15165580.
ALL DIODES, LED, 94372500.
ALL DIODE ARRAYS, D116, 50241801.
ALL RESISTOR PACK RESISTORS, ±3%, 1/8 W.
ALL TRANSISTORS, SPNP, MM5005, 5022400.
ALL TRANSISTOR ARRAYS, NPN, MPQ2369, 50213300.
ALL ○—○ INDICATE MOLDED JUMPER WIRES.
- INPUT PINS OF UNUSED LOGIC ELEMENT 74LS20 TO GROUND.
- SEE TABLE FOR .1 uF FILTER CAP LOCATIONS.
- FOR EASE OF LOCATING WHICH PAGE A CONNECTOR PIN IS ON SEE PIN/SHEET CROSS REFERENCE DIAGRAMS ON SHEET 2.
- DIODE, SILICON, 24552500.
- DIODE, SILICON, 1N4001, 95637301.
- DIODE, SILICON, 1CV 17, 50240113.
- TRANSISTOR, SPNP, 2N3569, 50210801.
- TRANSISTOR, SPNP, 2N3645, 50211200.
- TRANSISTOR ARRAY, MPQ3546, 15165619.
- TEST SELECT RESISTORS TO BE SELECTED FROM DRAWING 94357500 AND INSERTED DURING CARD TEST PER CARD TEST REQUIREMENTS.
- INPUT PINS OF UNUSED LOGIC ELEMENT 74LS00 TO +5 V.
- DELAY TIME FOR REFERENCE ONLY.

REFERENCE DRAWING			MAGNETIC PERIPHERALS INC		TITLE	
COMP ASSY 54332101			A DIVISION OF		SCHEMATIC DIAGRAM	
CTR 54332301			FIRST USED ON		RSD CONTROL BOARD	
			PASAI-A		TYPE BPEX	
NEXT ASSEMBLY			54332101			
COMPONENTS EXCEPT AS NOTED			DWN D G DONAT		5-26-82	
TOLERANCE	VALUE	RATING	CHRD	DGD	7/1/82	
RES ±5%	OHMS	1/4 W	ENGR	R. Nelson	7/1/82	
CAP ±10%			MFG	K. M. Gault	7-20-82	
			QA	M. Gault	9-20-82	
SMALL DISK DIVISION			SCALE		0401	
C 83324630			CODE SHEET 1 OF 23		PAGE 1-61	
REF: 54332201			1		PRODUCT RSD	

SIGNAL INPUTS

0102 P26-11 ~~11~~ >> ~~J26~~

SIGNAL OUTPUTS

J23 >> 02	0502 P23-02
J23 >> 04	0502 P23-04
J23 >> 06	0502 P23-06
J23 >> 08	0502 P23-08
J23 >> 10	0502 P23-10
J23 >> 12	0502 P23-12
J23 >> 14	0502 P23-14
J24 >> 02	0601 P24-02
J24 >> 04	0601 P24-04
J24 >> 08	0601 P24-08
J24 >> 10	0601 P24-10
J24 >> 12	0601 P24-12
J24 >> 14	0601 P24-14
J25 >> 04	1042 P25-04
J25 >> 01	1042 P25-01
J25 >> 10	1042 P25-10
J26 >> 02	0101 P26-02
J26 >> 04	0101 P26-04
J26 >> 01	0101 P26-01
J26 >> 06	0101 P26-06
J28 >> 06	0301 J34-02
J29 >> 03	0801 J30-24
J29 >> 04	0701 J31-24
J29 >> 01	0801 J30-23
J29 >> 01	0701 J31-23
J29 >> 02	0801 J30-26
J29 >> 02	0701 J31-26
J29 >> 02	0801 J30-25
J29 >> 02	0701 J31-25
J29 >> 12	0801 J30-15
J29 >> 12	0701 J31-15
J29 >> 15	0801 J30-12
J29 >> 15	0701 J31-12

LOGIC CROSS REFERENCE INFORMATION

PUB	83324630	REV	B
CROSS REF NO	0402	PAGE	1-62

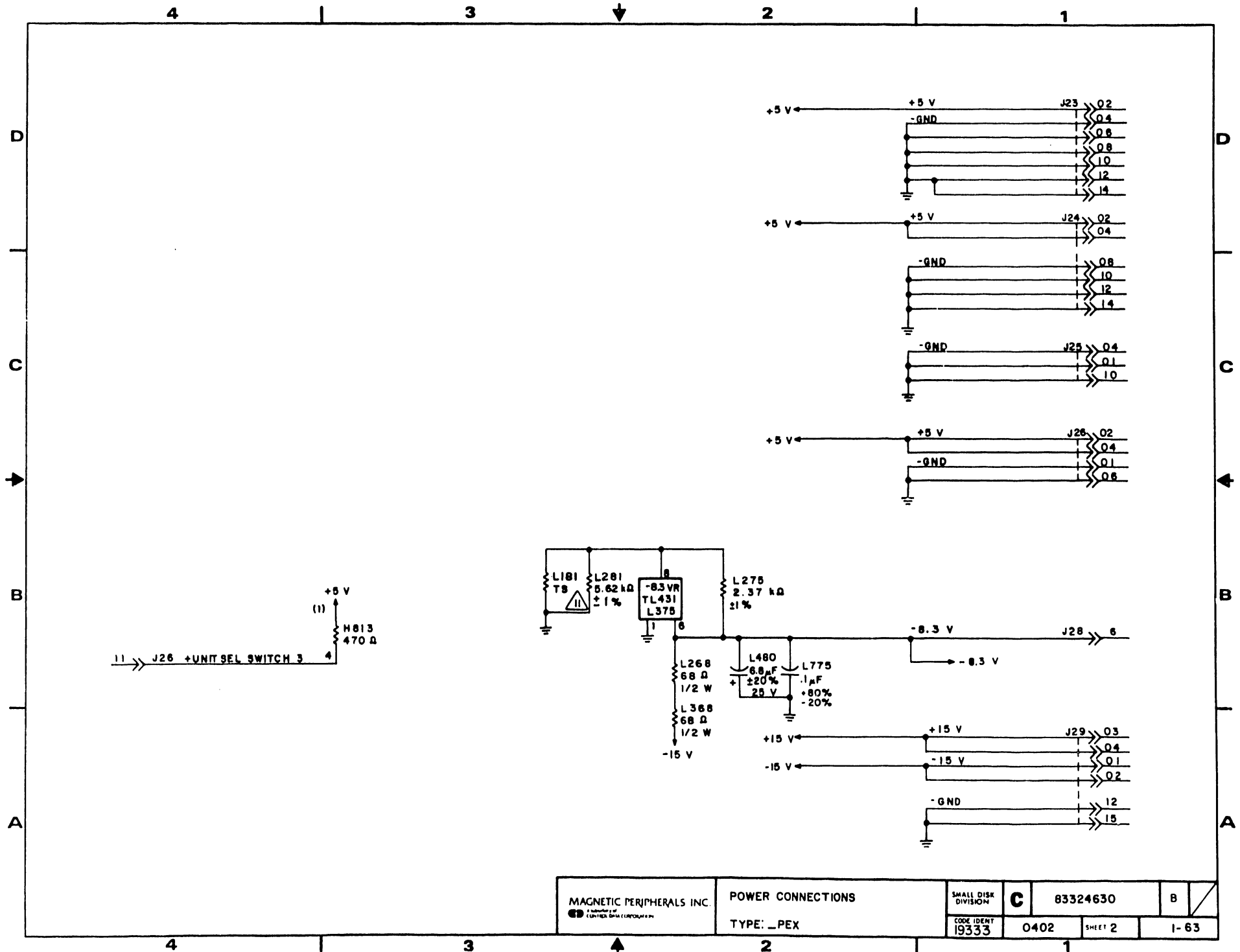

MAGNETIC PERIPHERALS INC. <small>A member of CENTRAL DATA CORPORATION</small>	POWER CONNECTIONS	SMALL DISK DIVISION	C	83324630	B
	TYPE: _PEX	CODE IDENT 19333	0402	SHEET 2	1-63

SIGNAL INPUTS

SIGNAL OUTPUTS

SINGLE		DUAL	
<u>CHANNEL UNITS</u>	<u>CHANNEL UNITS</u>	<u>CHANNEL UNITS</u>	<u>CHANNEL UNITS</u>
0206	J20-18	0212	J20-23

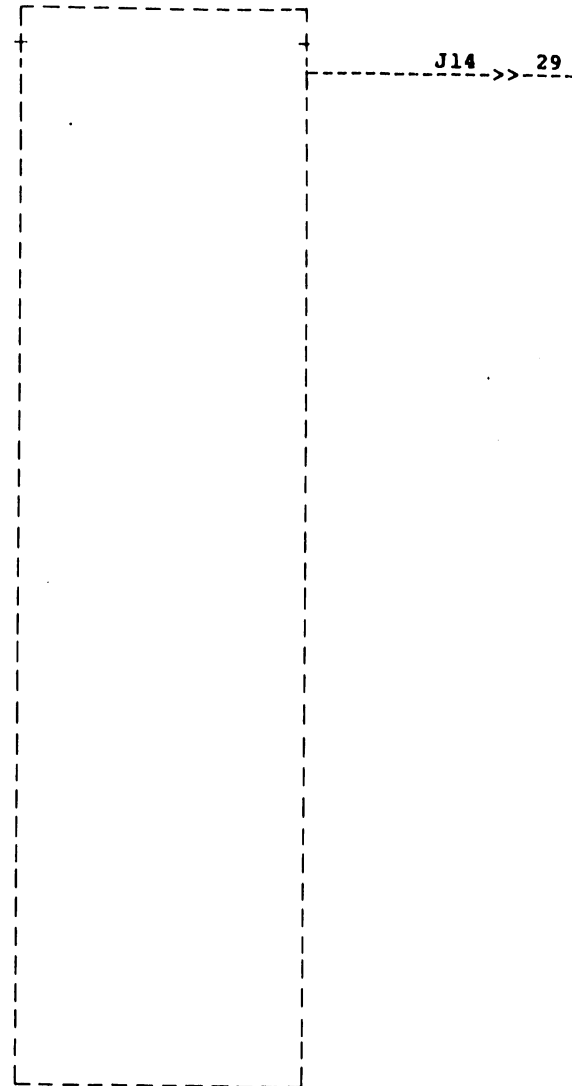

LOGIC CROSS REFERENCE INFORMATION

PUB	83324630	REV	B
CROSS REF NO	0403	PAGE	1-64

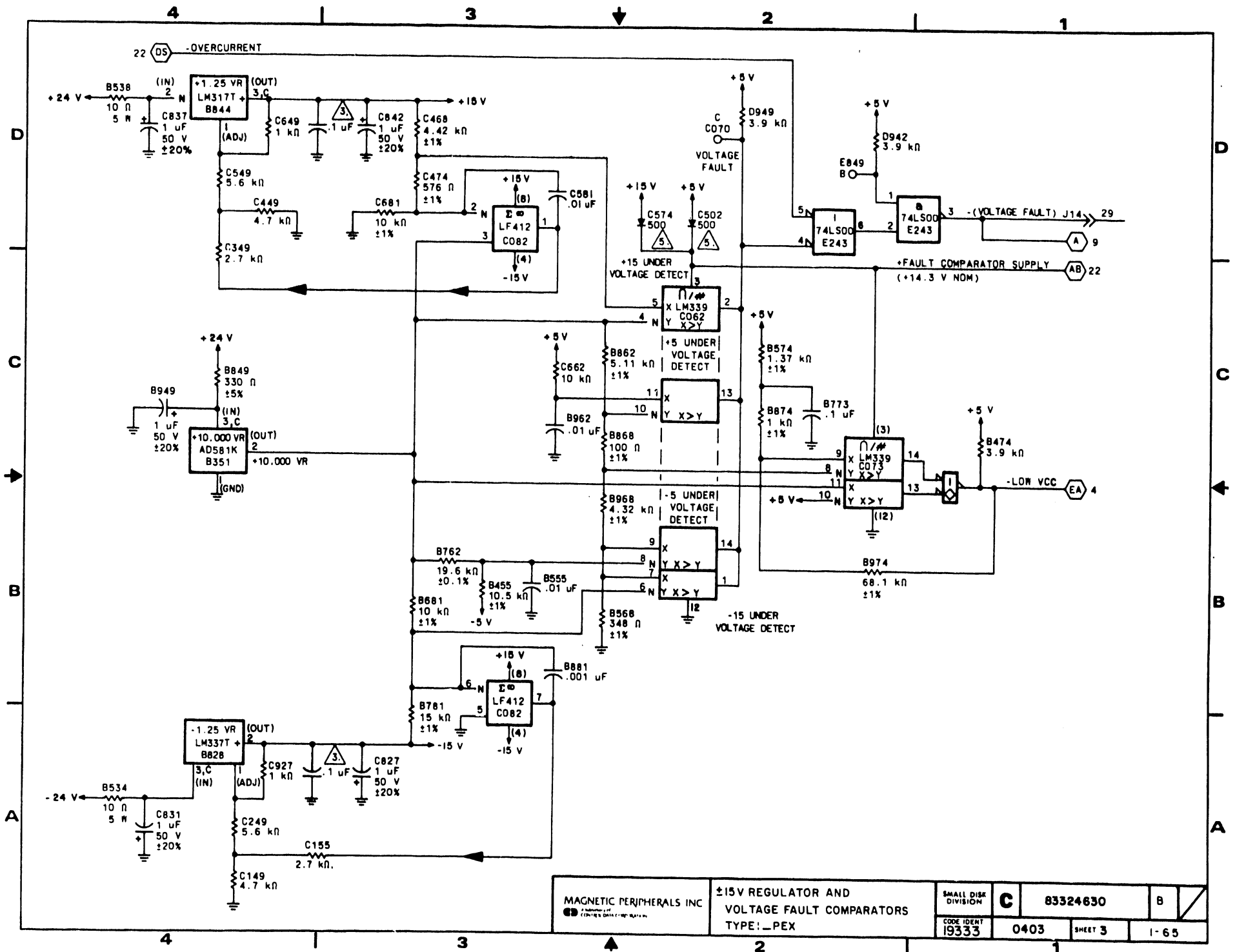

MAGNETIC PERIPHERALS INC A DIVISION OF CONRAD ELECTRONIC CORPORATION	±15V REGULATOR AND VOLTAGE FAULT COMPARATORS TYPE: -PEX		SMALL DISK DIVISION	C	83324630	B
	CODE IDENT 19333	0403	SHEET 3	1-65		

SIGNAL INPUTS

SIGNAL OUTPUTS

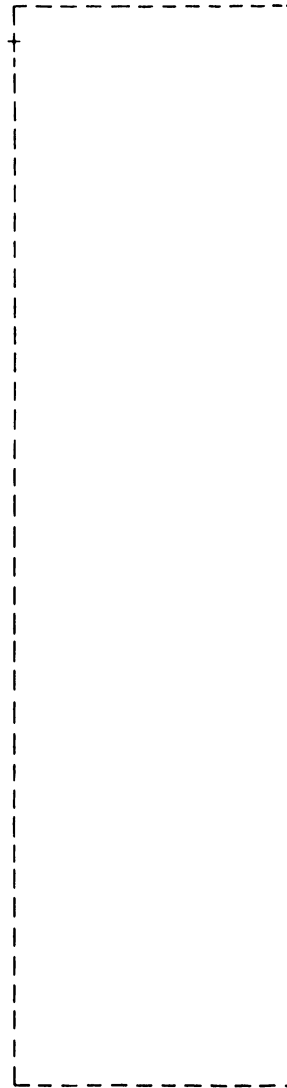

		<u>SINGLE</u>	<u>DUAL</u>
		<u>CHANNEL UNITS</u>	<u>CHANNEL UNITS</u>
J14	--> 21	0206 J20-02	0210 J20-39
J24	--> 05	0602 P24-05	0602 P24-05

LOGIC CROSS REFERENCE INFORMATION

PUB	83324630	REV	D
CROSS REF NO	0404	PAGE	1-66

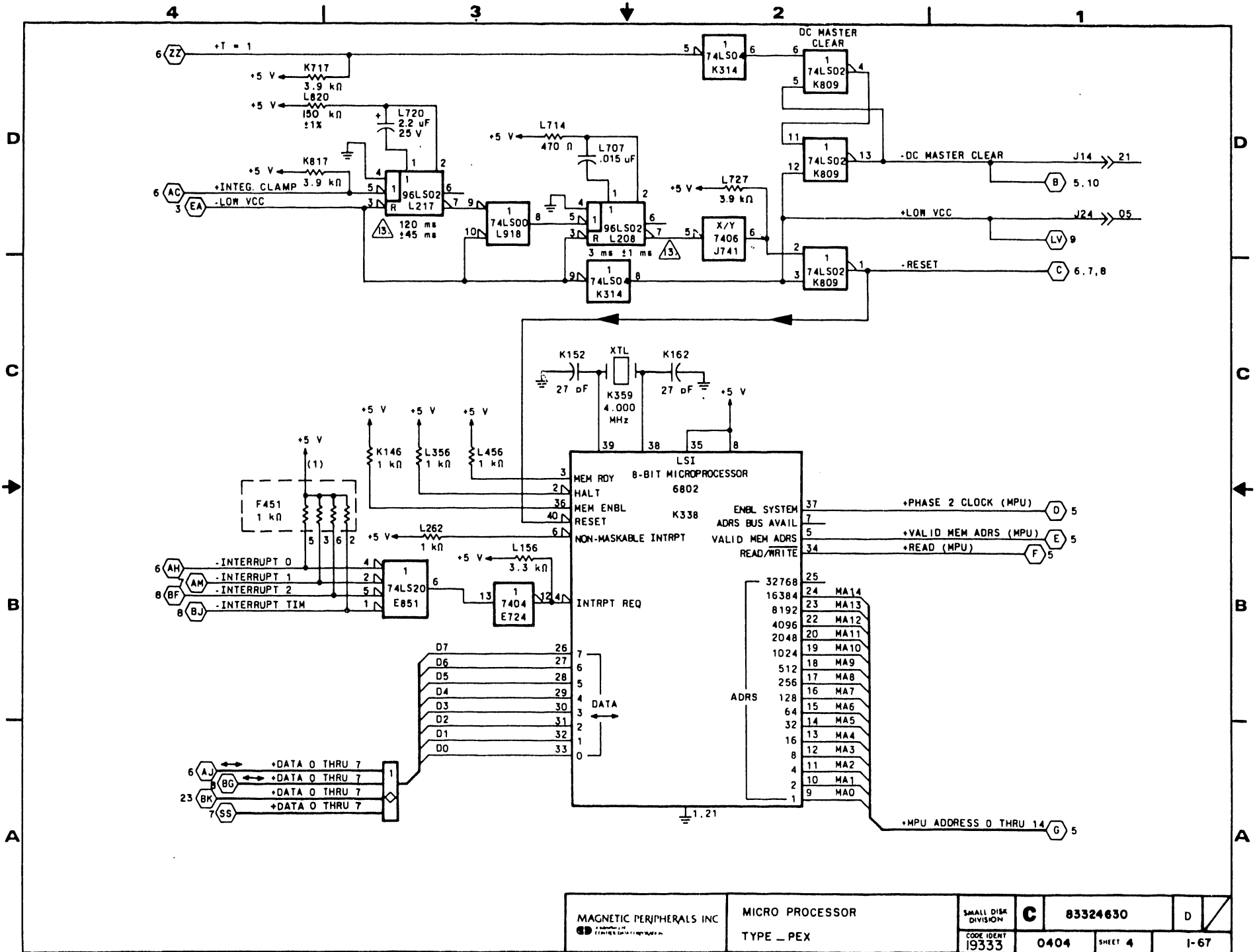

SIGNAL INPUTS

SINGLE CHANNEL UNITS		DUAL CHANNEL UNITS		
0202	J20-05	0202	J20-36	18 --> J14
0202	J20-07	0202	J20-34	17 --> J14
0202	J20-11	0202	J20-30	15 --> J14
0202	J20-13	0202	J20-28	14 --> J14
0202	J20-15	0202	J20-26	13 --> J14
0202	J20-19	0202	J20-22	11 --> J14
0102	P26-05	0102	P26-05	05 --> J26
0102	P26-03	0102	P26-03	03 --> J26
0102	P26-09	0102	P26-09	09 --> J26

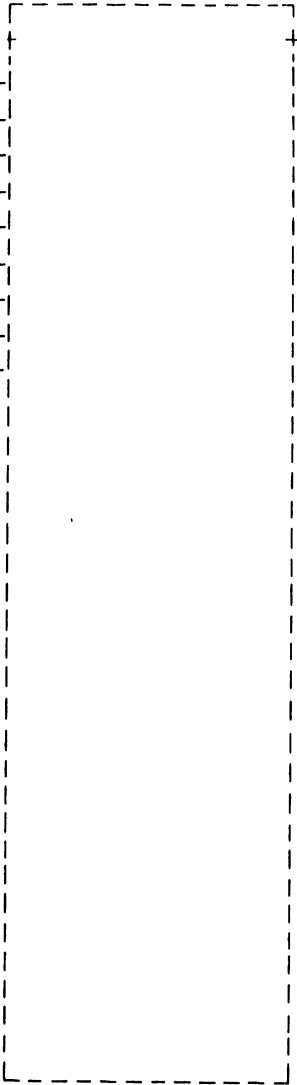

SIGNAL OUTPUTS

SINGLE CHANNEL UNITS		DUAL CHANNEL UNITS	
J26	07	0102	P26-07
J14	10	0202	J20-21
J14	22	NC	J20-04
J14	32	NC	J20-24
J14	07	NC	J20-27
J14	06	NC	J20-29

LOGIC CROSS REFERENCE INFORMATION

PUB	83324630	REV	B
CROSS REF NO	0405	PAGE	1-68

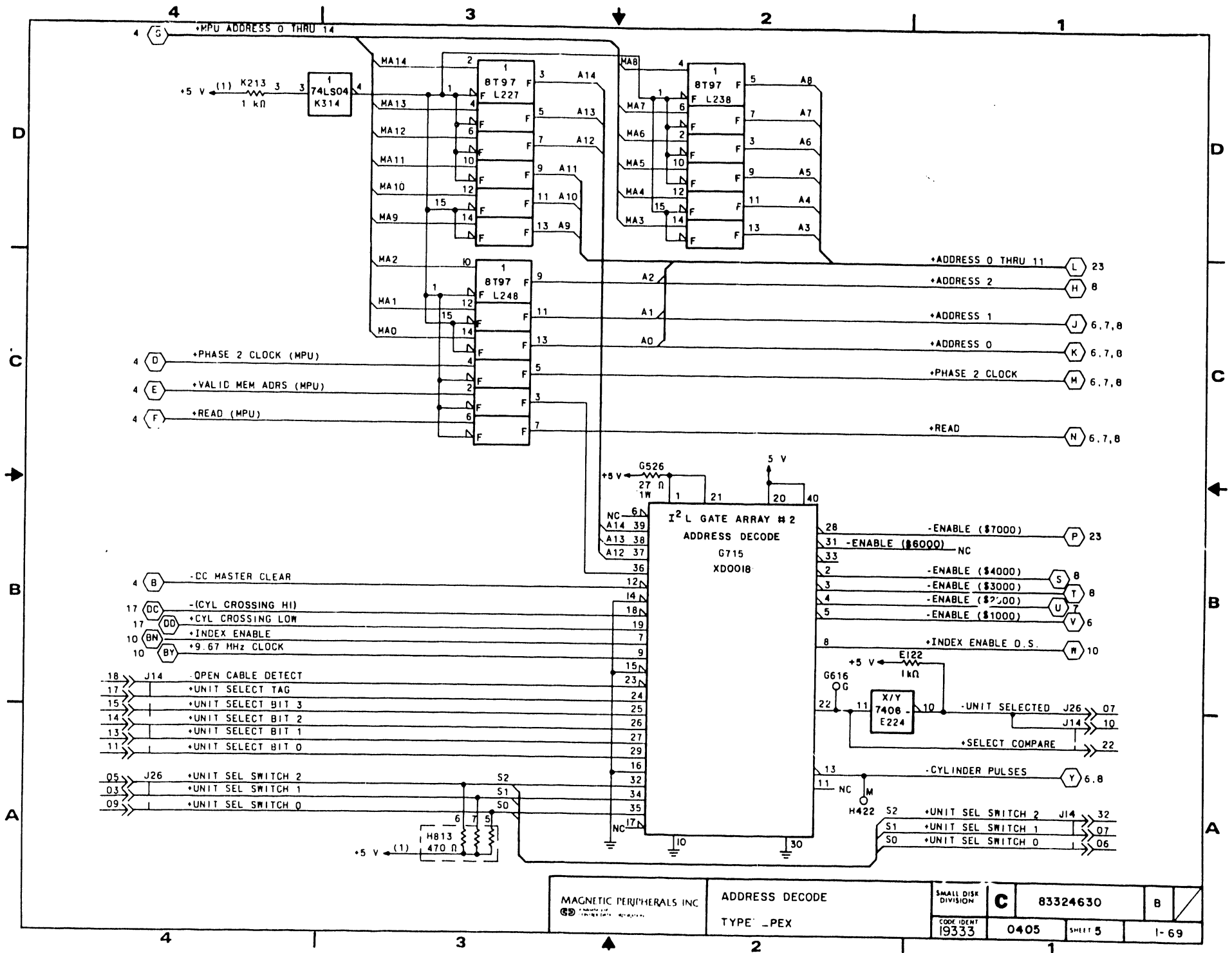

MAGNETIC PERIPHERALS INC.
© 1977

ADDRESS DECODE
 TYPE -PEX

SMALL DISK
 DIVISION
 COO. IDENT
 19333

C 83324630

B

0405

SHEET 5

1-69

SIGNAL INPUTS

SINGLE CHANNEL UNITS		DUAL CHANNEL UNITS			
0206	J20-26	0212	J20-15	33	>> J14
0206	J20-39	0212	J20-02	01	>> J14
0206	J20-28	0212	J20-13	34	>> J14
0206	J20-10	0212	J20-31	25	>> J14
1042	P25-05	1042	P25-05	05	>> J25
0206	J20-37	0212	J20-04	02	>> J14
0206	J20-35	0212	J20-06	03	>> J14
0206	J20-33	0212	J20-08	04	>> J14
0206	J20-31	0212	J20-10	05	>> J14

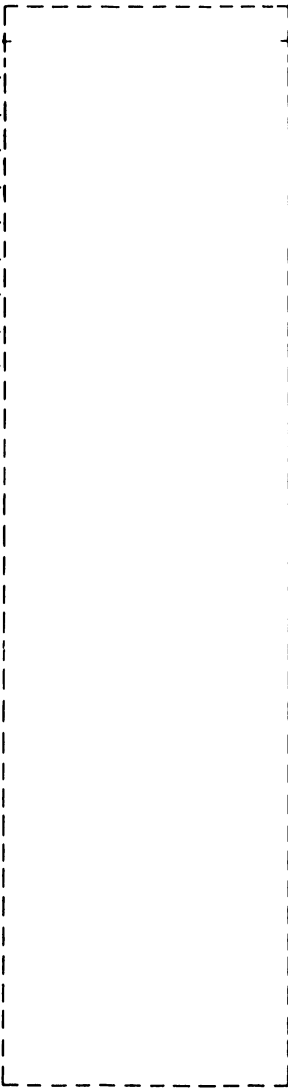

SIGNAL OUTPUTS

SINGLE CHANNEL UNITS		DUAL CHANNEL UNITS			
0206	J20-25	0212	J20-16	J14	>> 08
0206	J20-23	0212	J20-18	J14	>> 09
0204	J20-17	0204	J20-24	J14	>> 12
0701	J31-07	0701	J31-07	J29	>> 20
0805	J30-07	0805	J30-07	J29	>> 22
0701	J31-05	0701	J31-05	J29	>> 24
0805	J30-05	0805	J30-05	J29	>> 24
0701	J31-03	0701	J31-03	J29	>> 26
0805	J30-03	0805	J30-03	J29	>> 26
0701	J31-01	0701	J31-01	J29	>> 26
0805	J30-01	0805	J30-01	J29	>> 26

LOGIC CROSS REFERENCE INFORMATION

PUB	83324630	REV	B
CROSS REF NO	0406	PAGE	1-70

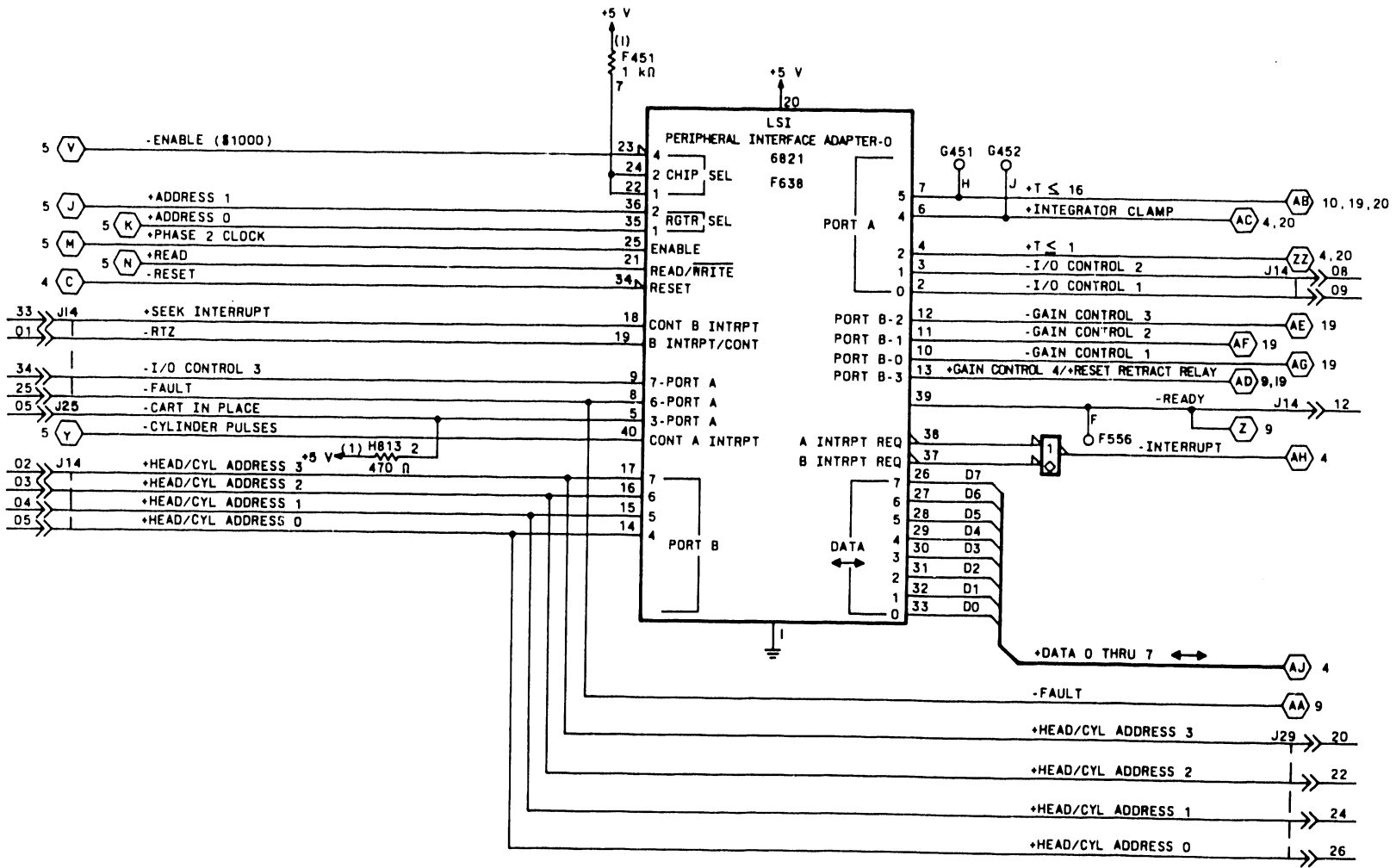

SIGNAL INPUTS

SINGLE CHANNEL UNITS		DUAL CHANNEL UNITS			
1042	P25-08	1042	P25-08	08	>> J25
1042	P25-02	1042	P25-02	02	>> J25
0102	P26-08	0102	P26-08	08	>> J26
0205	J20-20	0205	J20-21	30	>> J14
NC	J20-16	NC	J20-25	28	>> J14

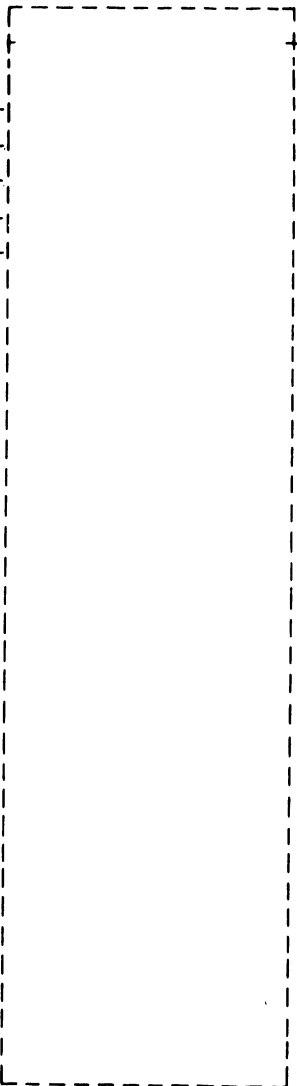

SIGNAL OUTPUTS

J24 >> 11 0602 P24-11

LOGIC CROSS REFERENCE INFORMATION

PUB 83324630		REV B
CROSS REF NO 0407	PAGE 1-72	

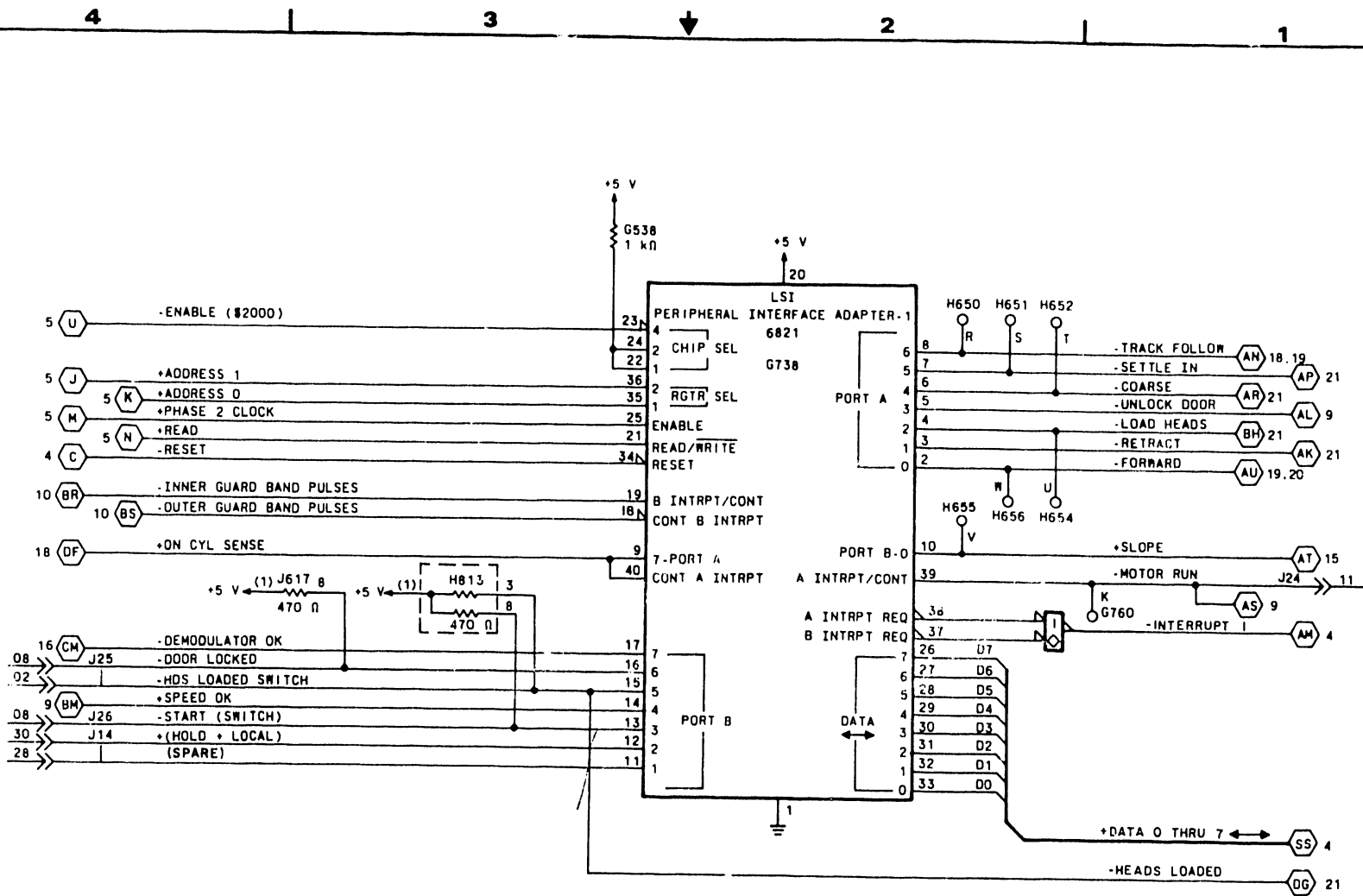

SIGNAL INPUTS

0602 P24-09 -09-->>-J24
0102 P26-10 -10-->>-J26
0602 P24-07 -07-->>-J24

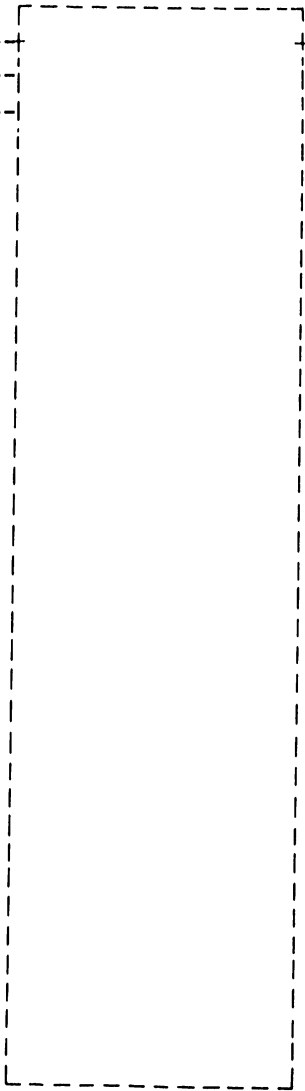

SIGNAL OUTPUTS

LOGIC CROSS REFERENCE INFORMATION

PUB	83324630	REV	B
CROSS REF NO	0408	PAGE	1-74

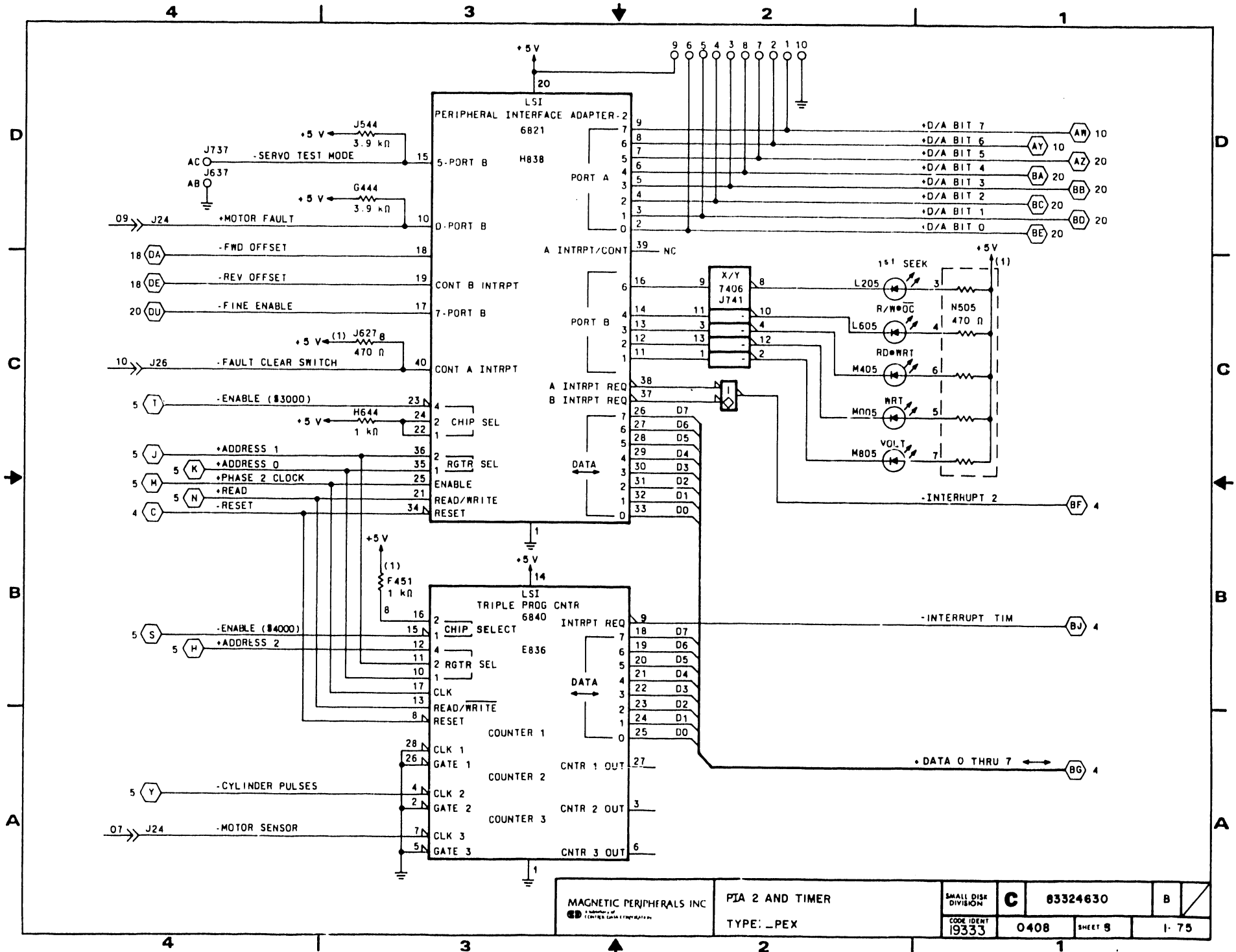

SIGNAL INPUTS

SINGLE CHANNEL UNITS		DUAL CHANNEL UNITS			
0603	P24-03	0603	P24-03	03	J24
0602	P24-01	0602	P24-01	01	J24
0206	J20-12	0212	J20-29	26	J14
1042	O25-03	1042	P25-03	03	J25

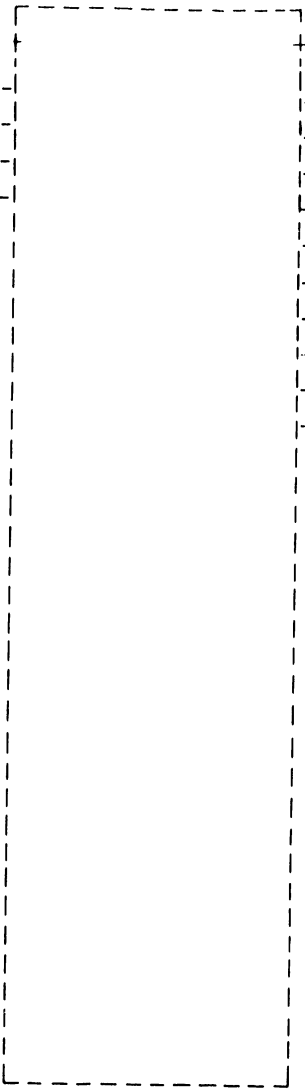

SIGNAL OUTPUTS

SINGLE CHANNEL UNITS		DUAL CHANNEL UNITS	
J23	>> 13	0502	P23-13
J26	>> 13	0102	P26-13
J25	>> 06	1042	P25-06
J25	>> 07	1042	P25-07
J24	>> 06	0602	P24-06
J14	>> 31	0206	J20-22
J29	>> 09	0802	J30-18
J14	>> 24	0204	J20-08
J26	>> 14	0102	P26-14
J26	>> 12	0102	P26-12

LOGIC CROSS REFERENCE INFORMATION

PUB	83324630	REV	B
CROSS REF NO	0409	PAGE	1-76

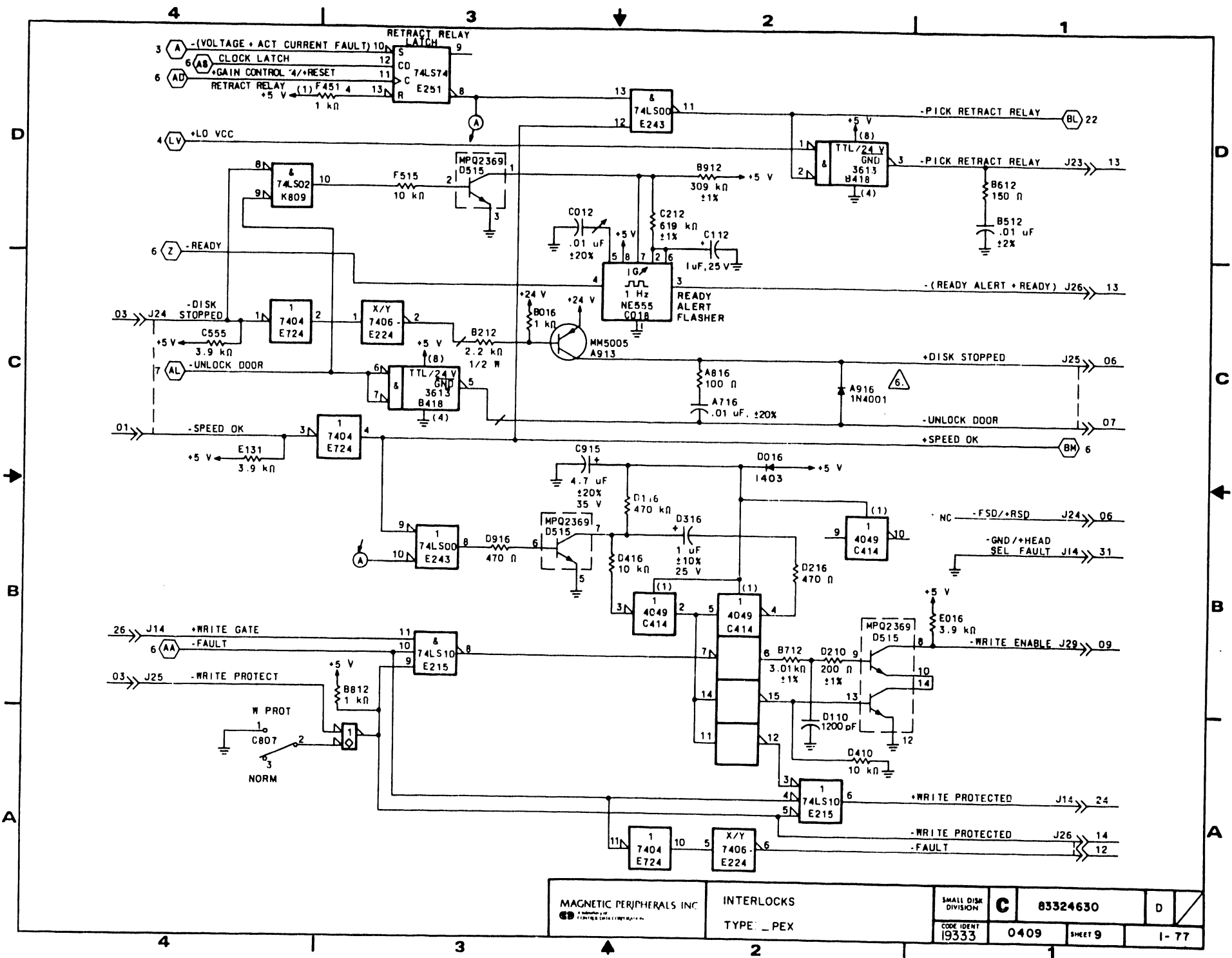

SIGNAL INPUTS

SINGLE CHANNEL UNITS		DUAL CHANNEL UNITS			
0206	J20-33	0212	J20-38	19	>> J14
0206	J20-06	0212	J20-35	23	>> J14
0703	J31-13	0703	J31-13	14	>> J29
0703	J31-14	0703	J31-14	13	>> J29
1042	P25-09	1042	P25-09	09	>> J25

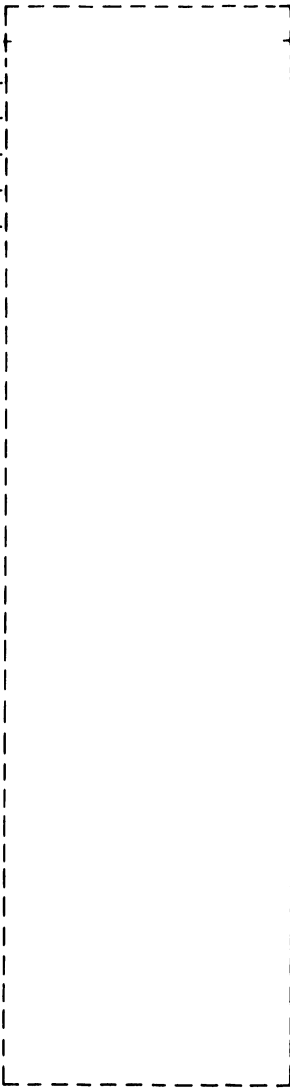

SIGNAL OUTPUTS

SINGLE CHANNEL UNITS		DUAL CHANNEL UNITS	
J14	>> 20	0204	J20-01
J14	>> 16	0205	J20-09
J14	>> 35	0204	J20-30
J24	>> 13	0603	P24-13

LOGIC CROSS REFERENCE INFORMATION

PUB		REV	
83324630		B	
CROSS REF NO	PAGE		
0410	1-78		

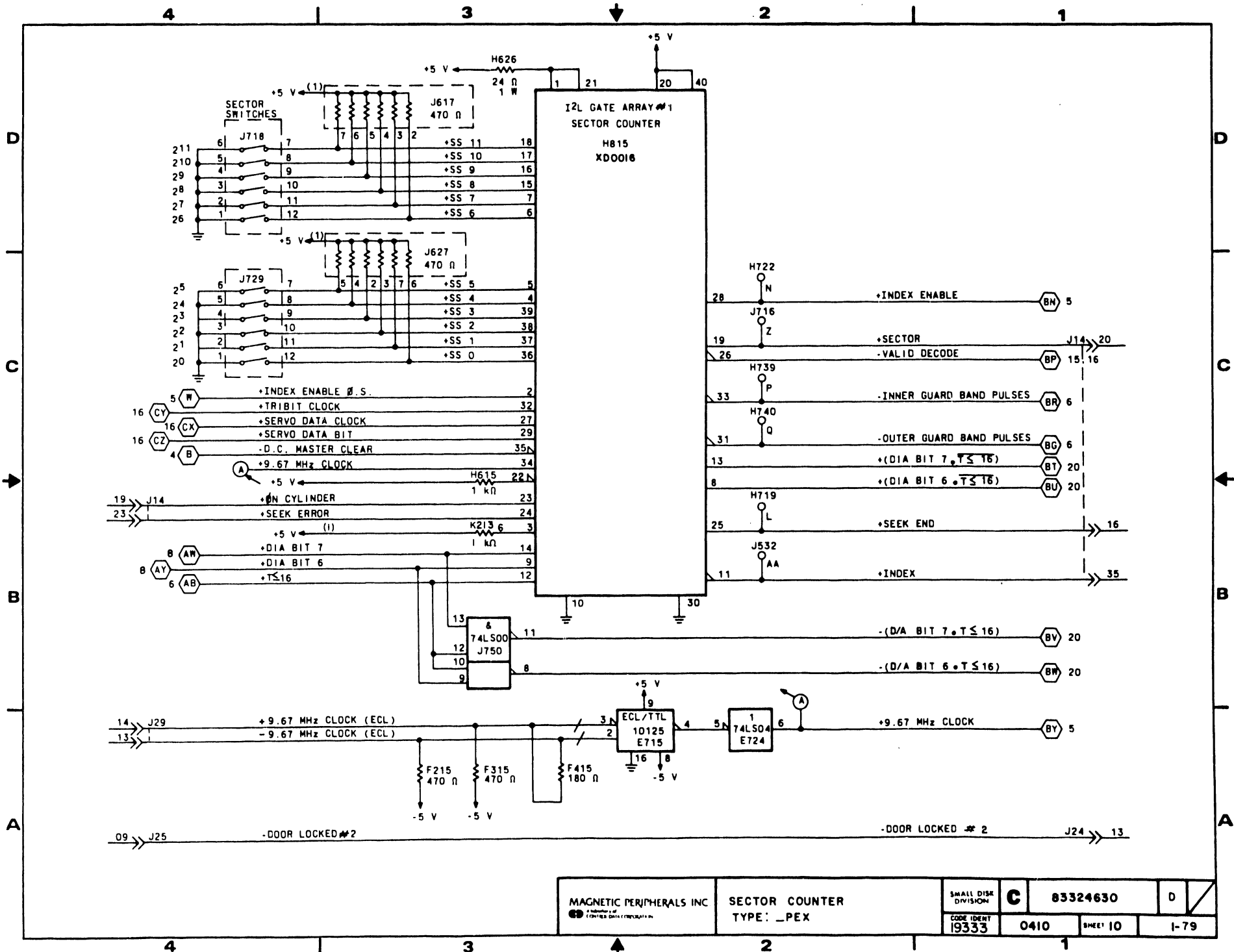

MAGNETIC PERIPHERALS INC A Division of CONVEX DATA CORPORATION	SECTOR COUNTER TYPE: _PEX	SMALL DISK DIVISION	C	83324630	D
	CODE IDENT 19333	0410	SHEET 10	1-79	

SIGNAL INPUTS

0302	J34-04	04	->>	J28
0301	J34-01	01	->>	J28
0301	J34-03	03	->>	J28
0301	J34-05	05	->>	J28
0302	J34-06	02	->>	J28

SIGNAL OUTPUTS

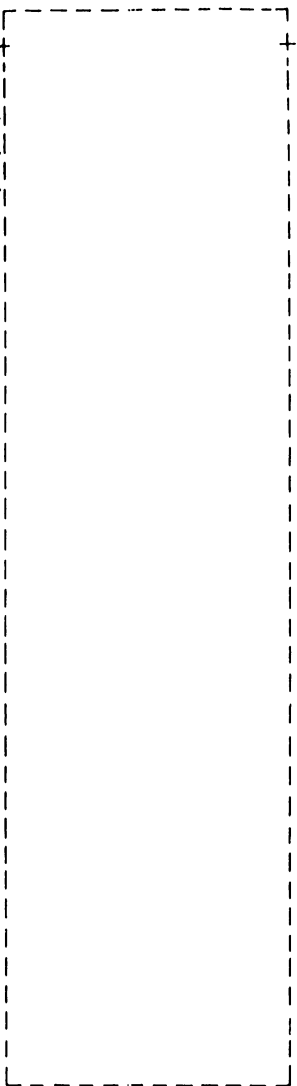

LOGIC CROSS REFERENCE INFORMATION

PUB	83324630	REV	B
CROSS REF NO	0411	PAGE	1-80

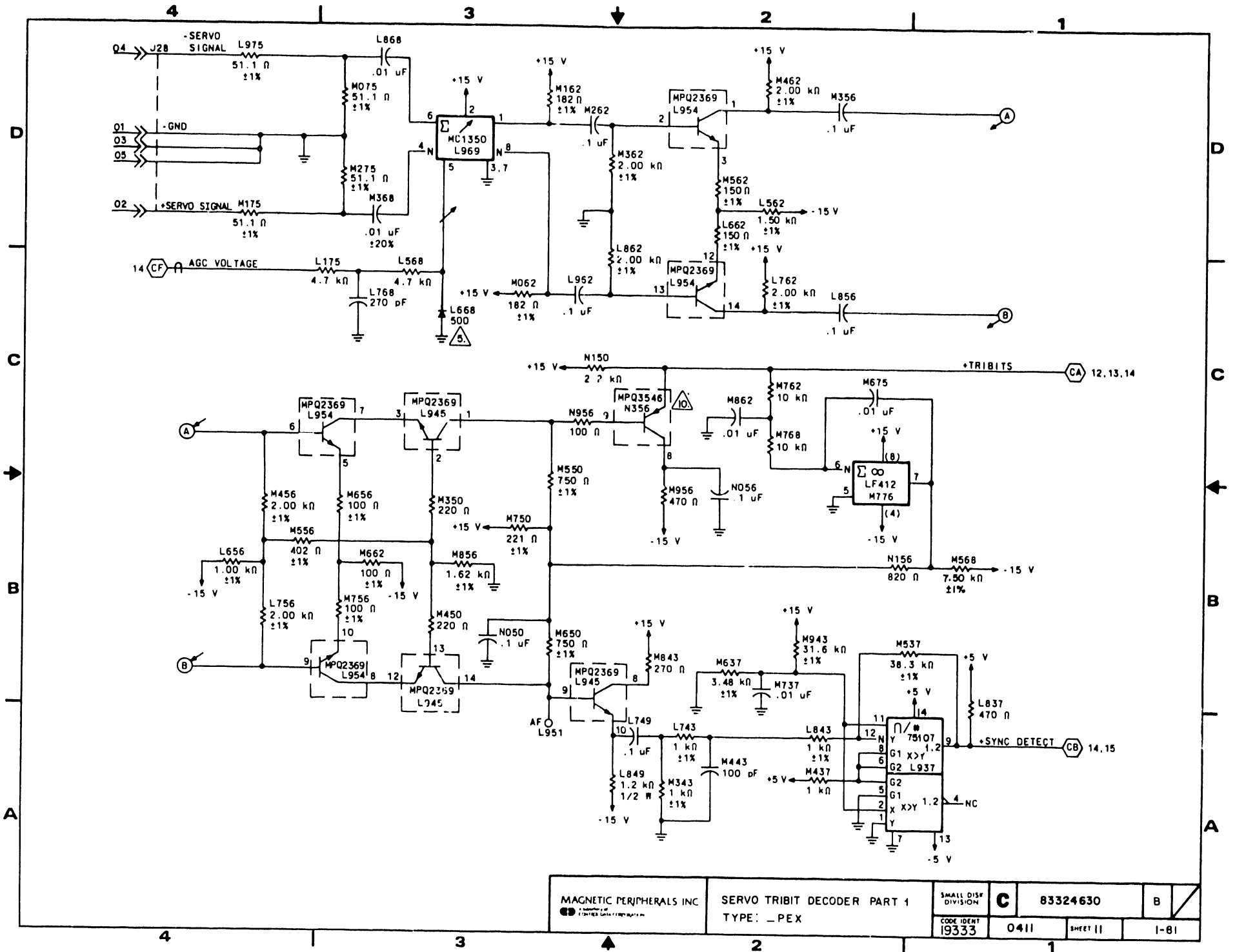

MAGNETIC PERIPHERALS INC
A Division of
 Spang

SERVO TRIBIT DECODER PART 1
 TYPE: - PEX

SMALL DISK DIVISION **C** 83324630

CODE IDENT 19333 0411 SHEET 11 I-81

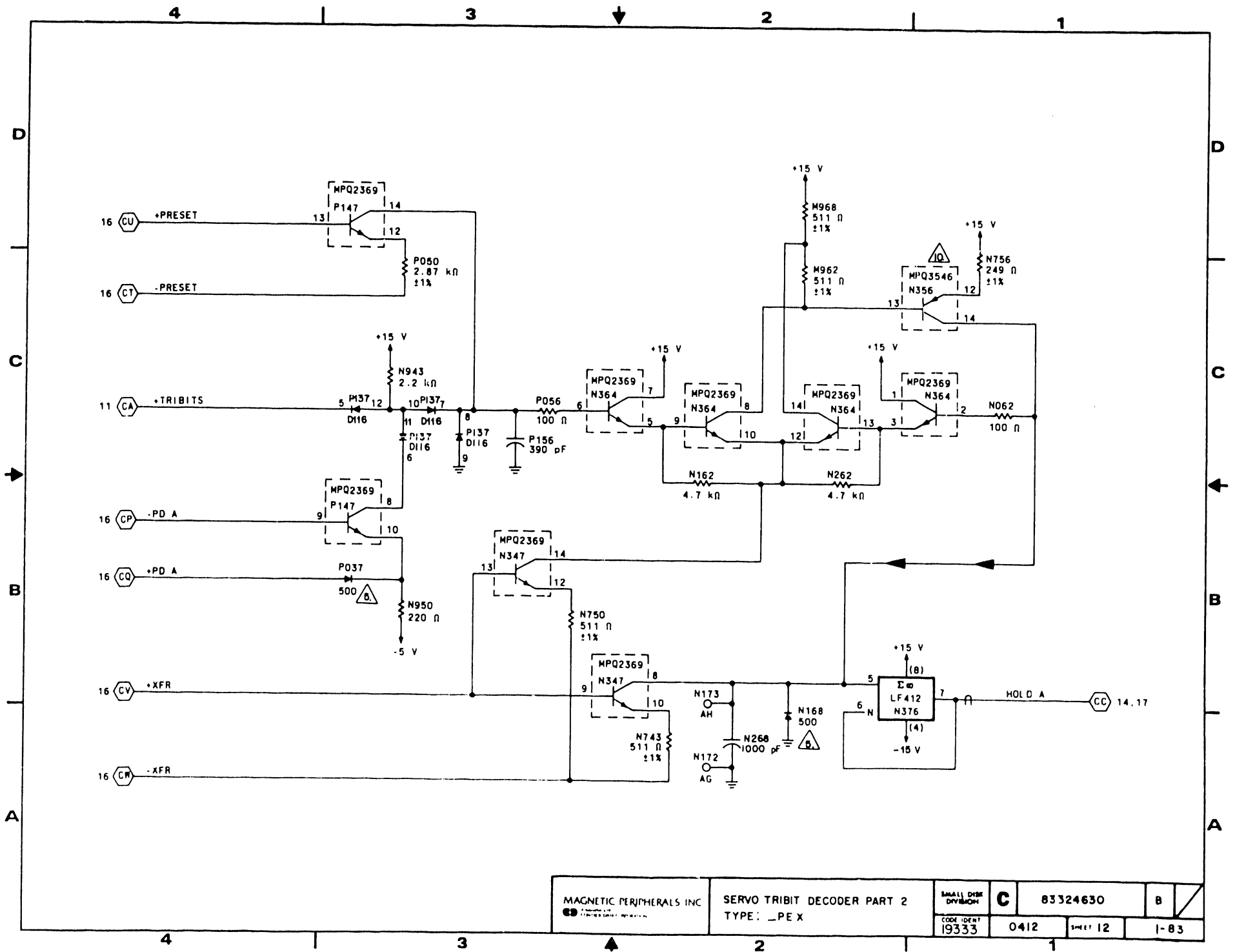

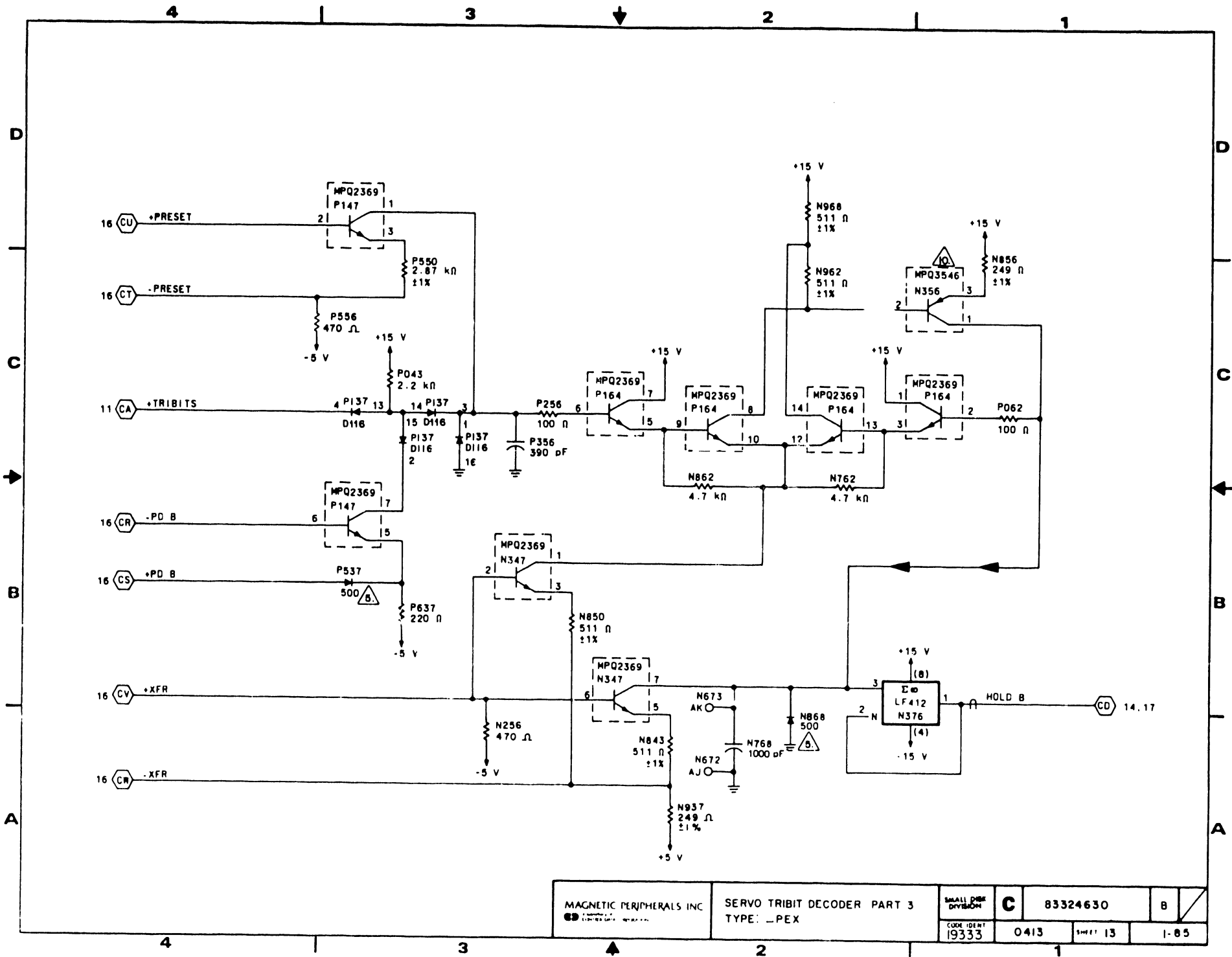

SIGNAL INPUTS

SIGNAL OUTPUTS

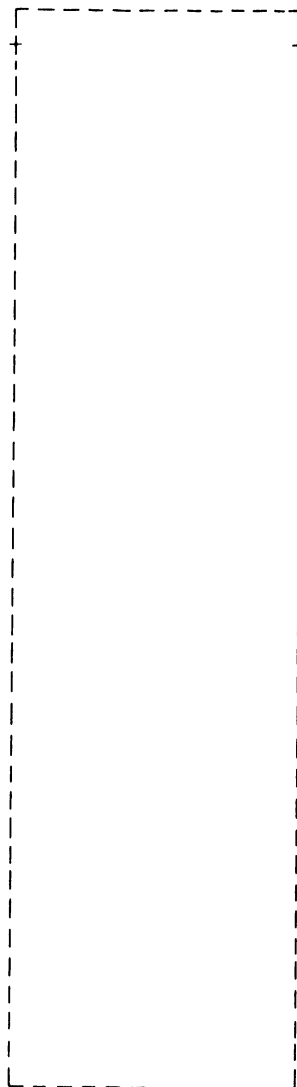

J29 >> 17

0703 J31-10
0801 J30-10

J29 >> 16

0703 J31-11
0801 J30-11

LOGIC CROSS REFERENCE INFORMATION

PUB	83324630	REV	B
CROSS REF NO	0414	PAGE	1-86

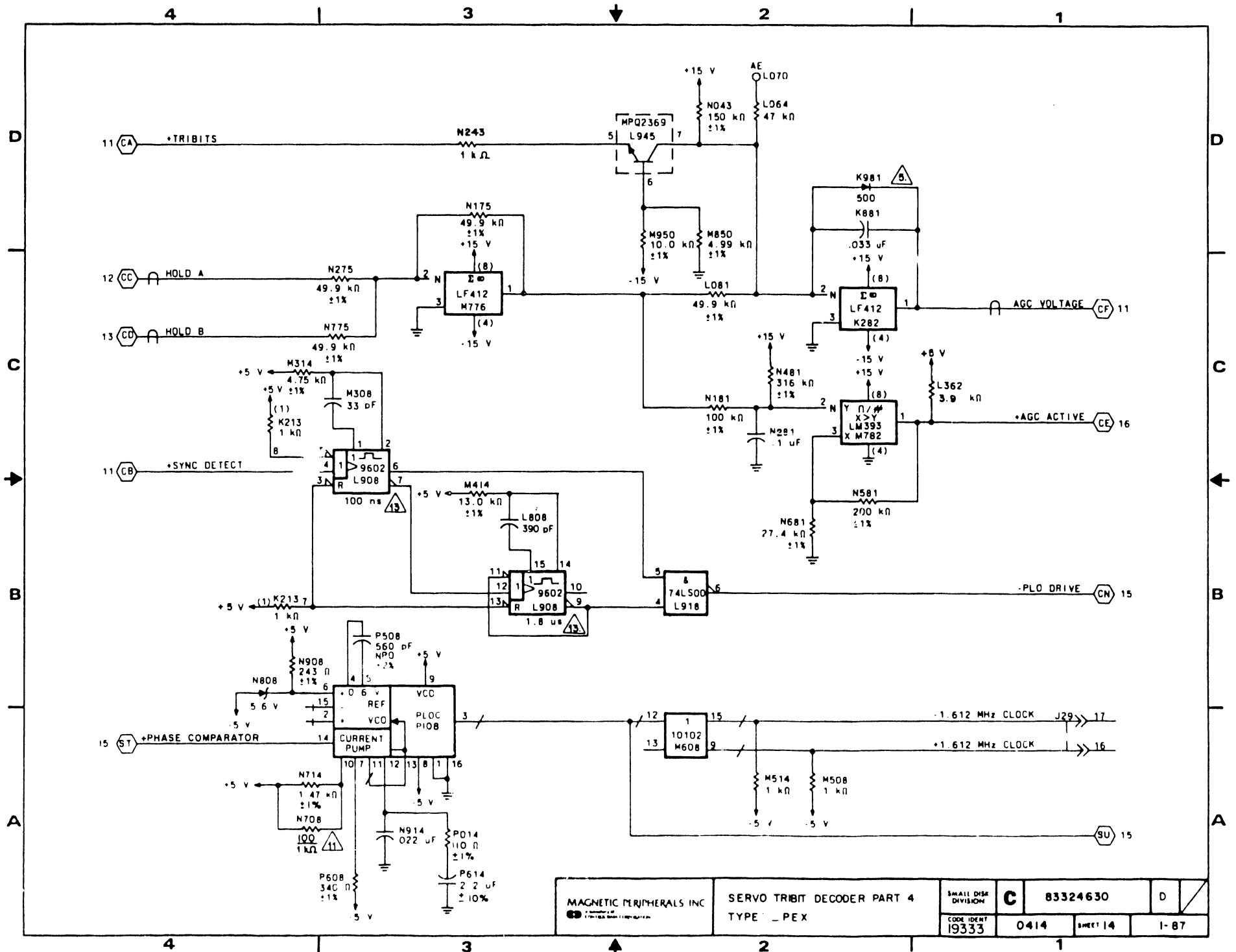

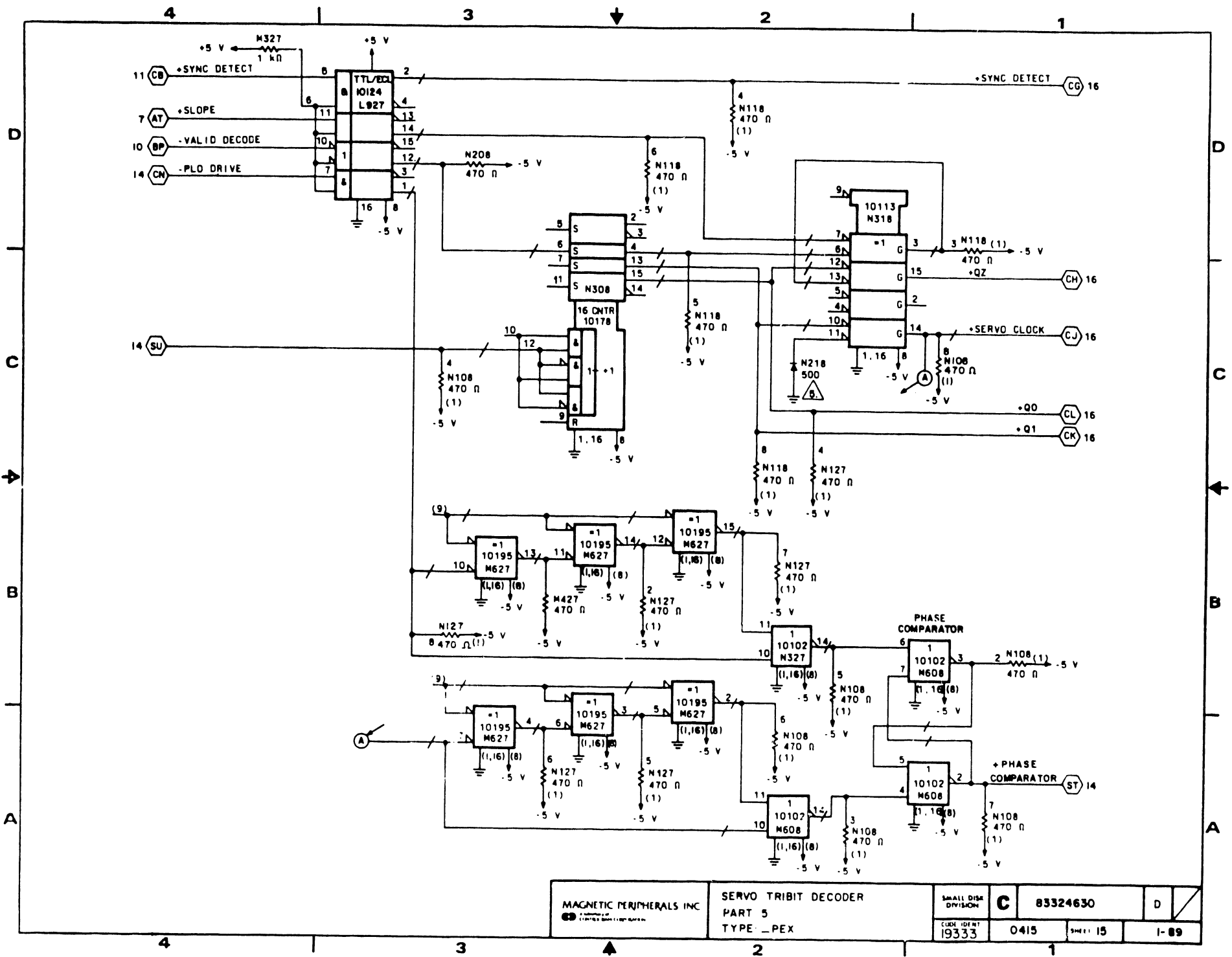

MAGNETIC PERIPHERALS INC A DIVISION OF CORNING GLASS WORKS	SERVO TRIBIT DECODER PART 5 TYPE - PEX		SMALL DISK DIVISION	C	83324630	D
	19333	0415	SHEET 15	1-89		

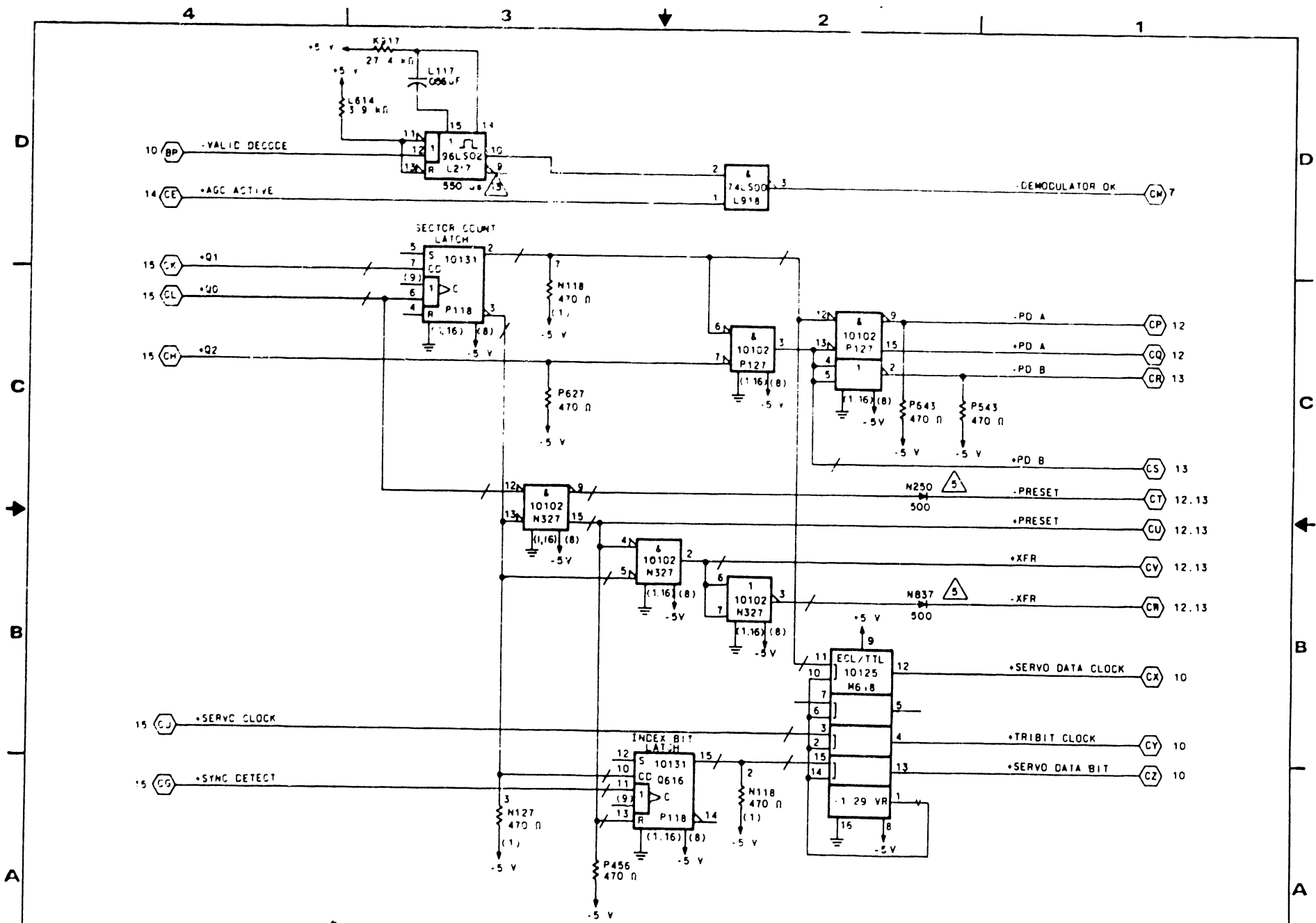

SIGNAL INPUTS

SIGNAL OUTPUTS

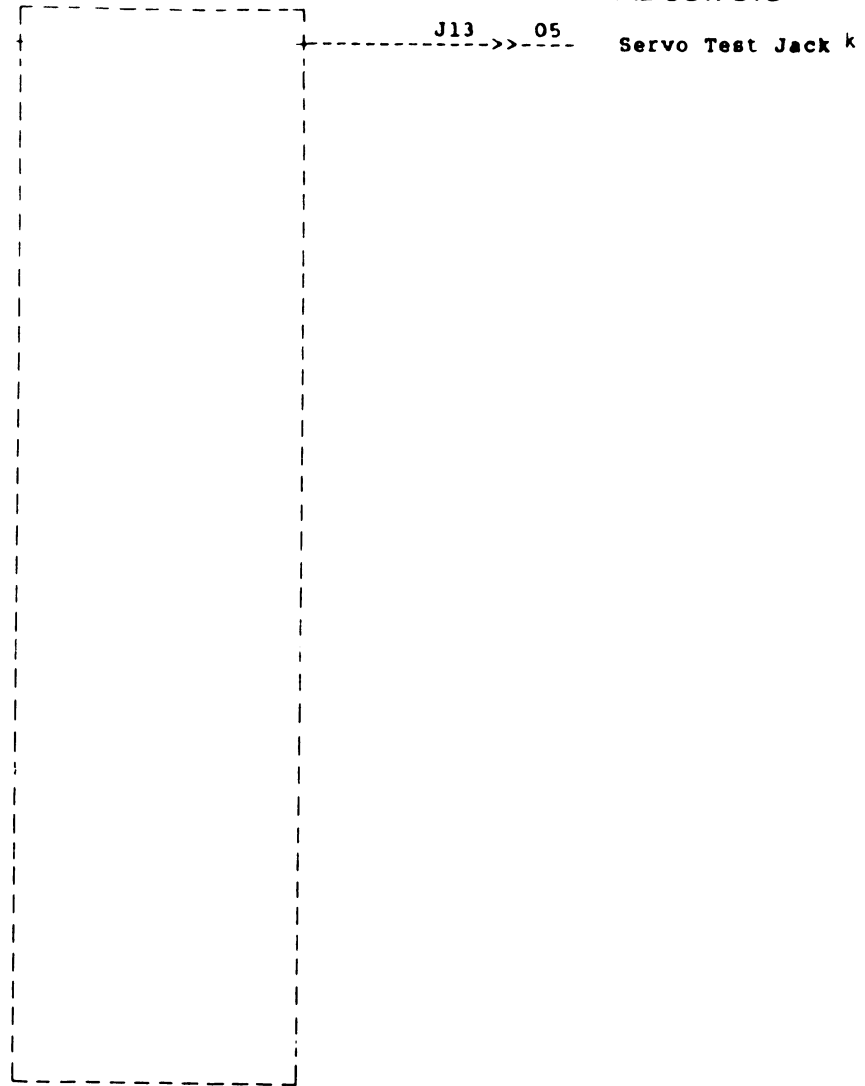

LOGIC CROSS REFERENCE INFORMATION

PUB	83324630	REV	B
CROSS REF NO	0417	PAGE	1-92

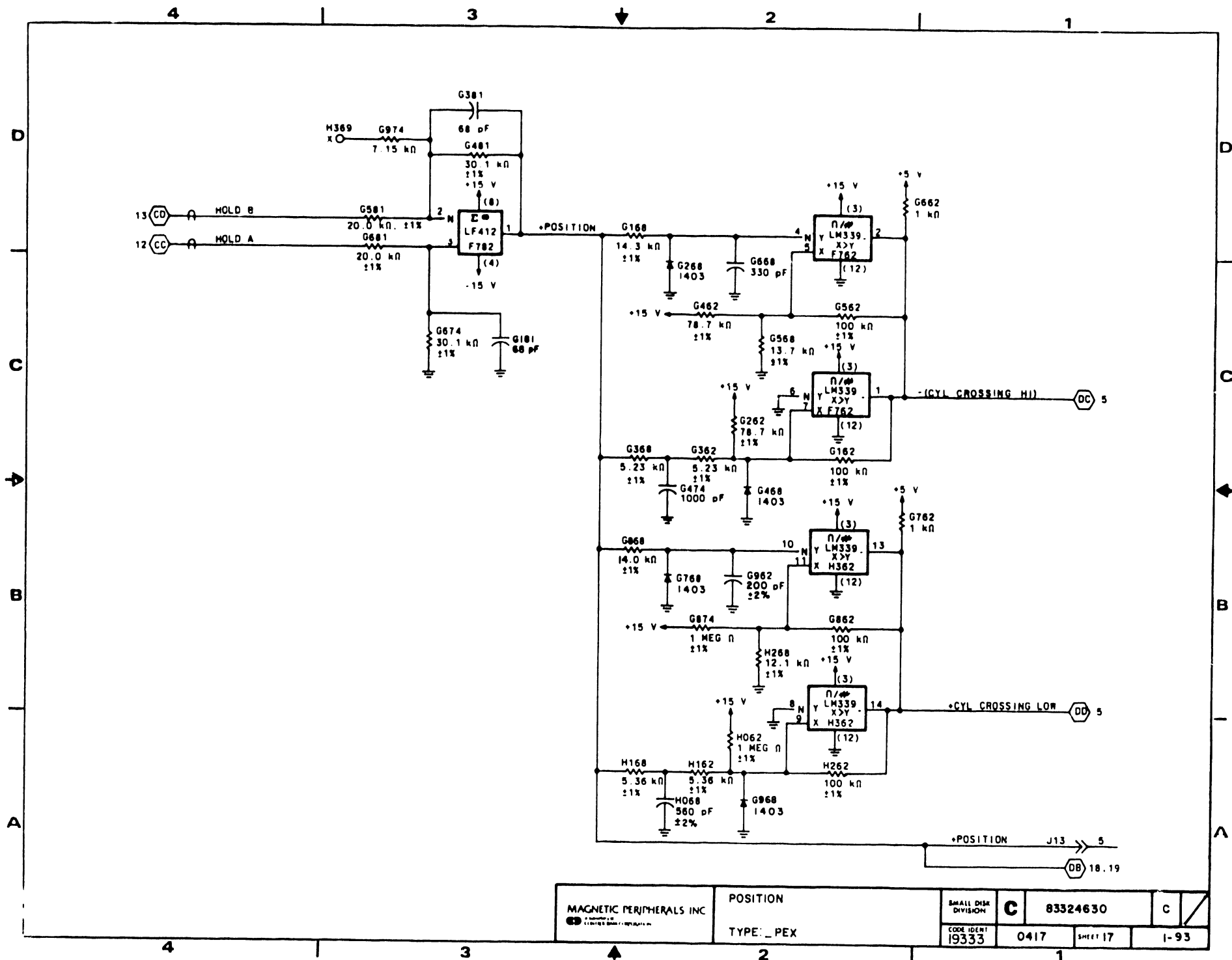

MAGNETIC PERIPHERALS INC CORPORATION 11111 11111	POSITION	SMALL DISK DIVISION	C	83324630	C
	TYPE: PEX	CODE IDENT	19333	0417	SHEET 17

SIGNAL INPUTS

SINGLE		DUAL			
CHANNEL	UNITS	CHANNEL	UNITS		
0206	J20-40	0212	J20-01	40	J14
0206	J20-38	0212	J20-03	39	J14

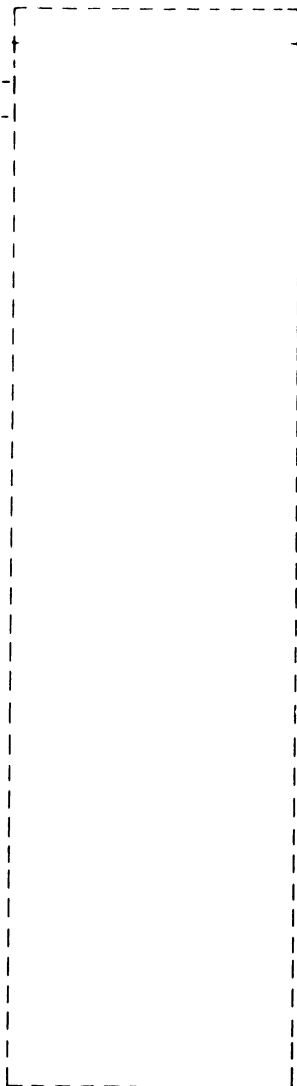

SIGNAL OUTPUTS

J13	>>	03	Servo Test Jack
J13	>>	04	Servo Test Jack
J13	>>	01	Servo Test Jack

LOGIC CROSS REFERENCE INFORMATION

PUB		REV	
83324630		B	
CROSS REF NO	PAGE		
0418	1-94		

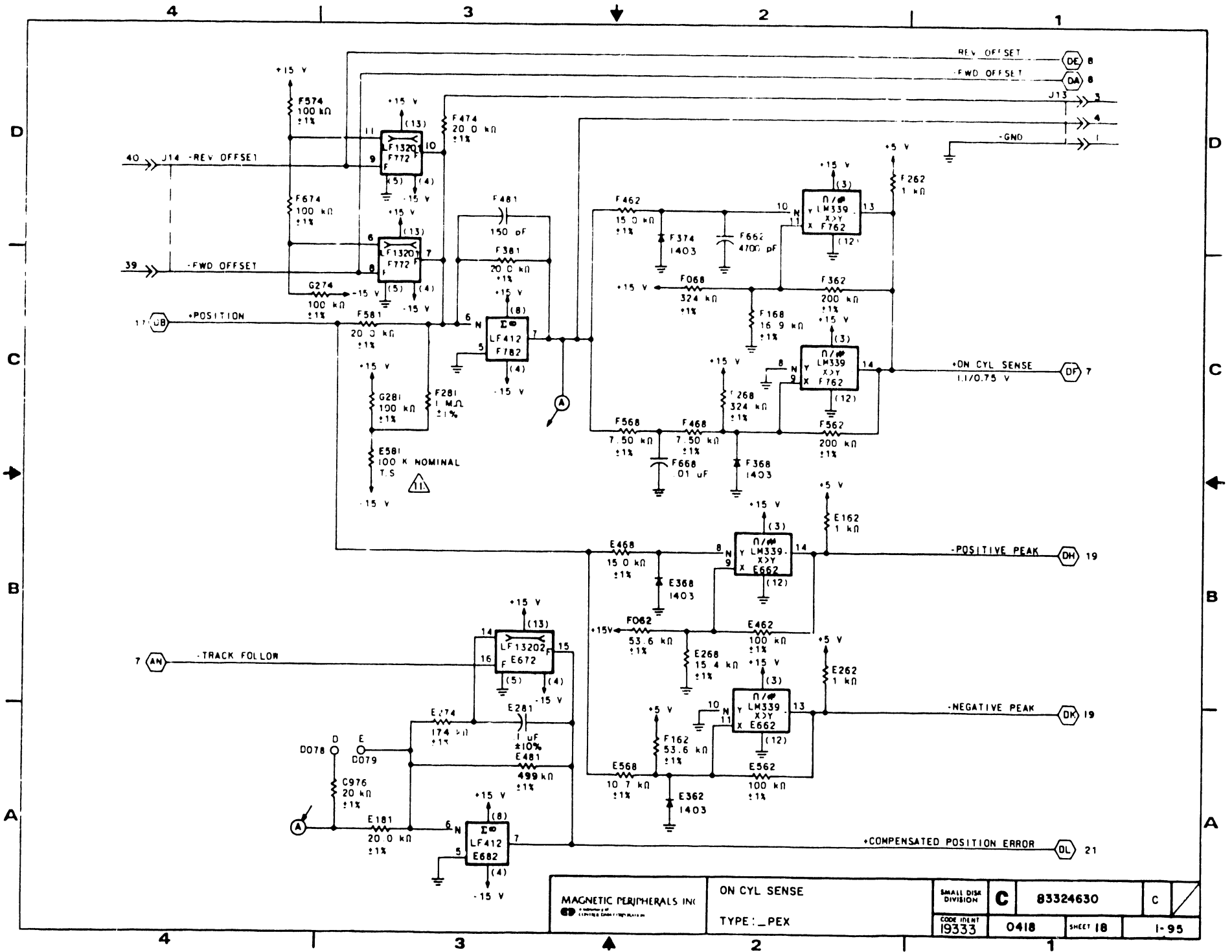

MAGNETIC PERIPHERALS INC. A DIVISION OF LITTON INDUSTRIES	ON CYL SENSE	SMALL DISK DIVISION	C	83324630	C
	TYPE: PEX	CODE IDENT 19333	0418	SHEET 18	I-95

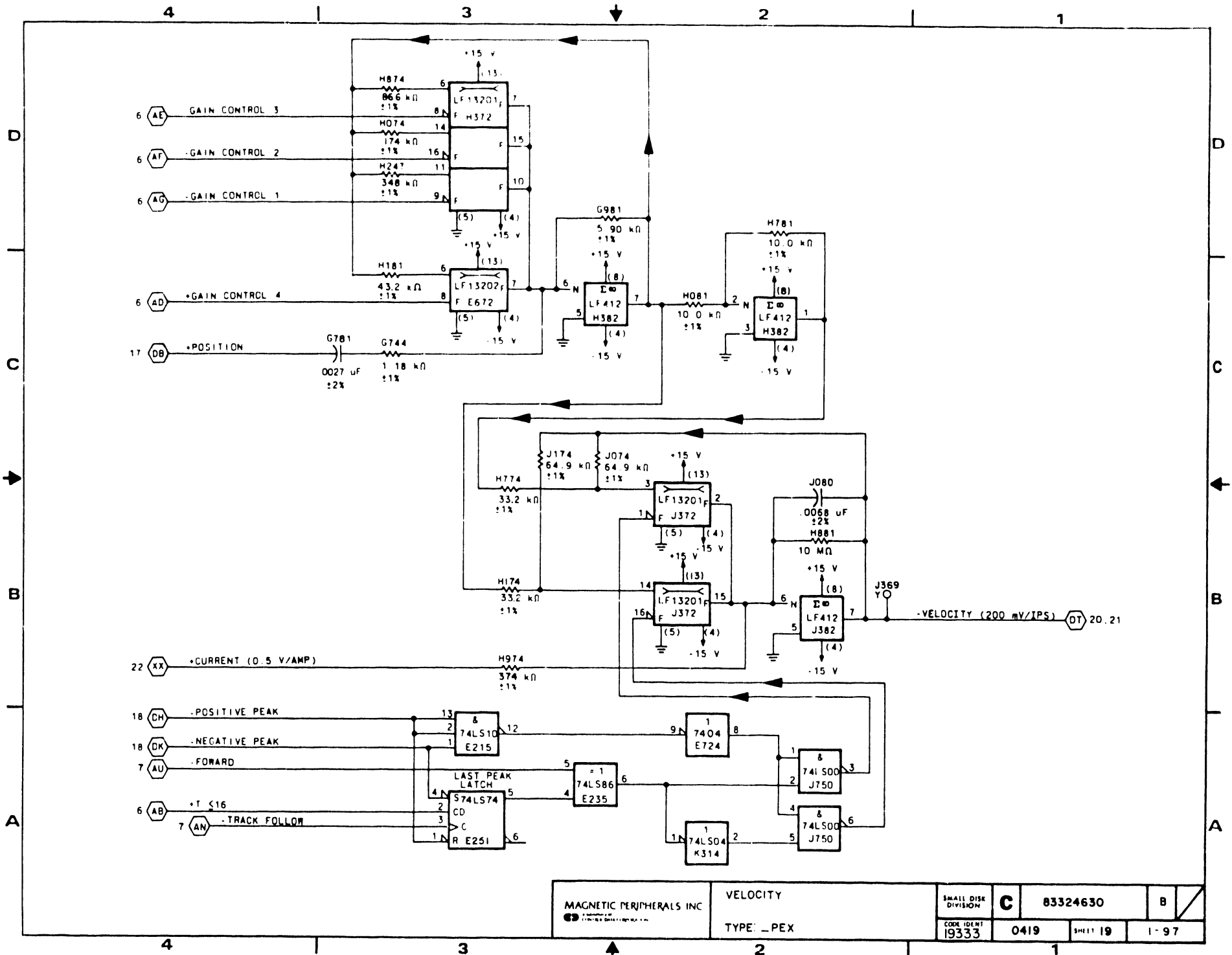

MAGNETIC PERIPHERALS INC A DIVISION OF GENERAL ELECTRIC COMPANY	VELOCITY	SMALL DISK DIVISION	C	83324630	B
	TYPE: -PEX	CODE IDENT 19333	0419	SHEET 19	1-97

SIGNAL INPUTS

SIGNAL OUTPUTS

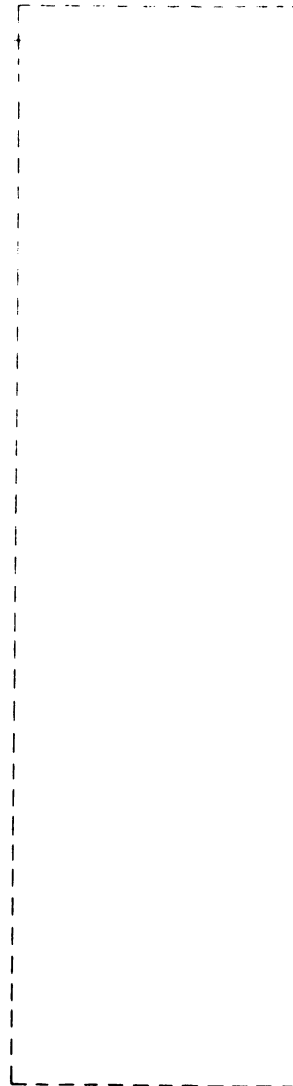

J29 → 21

0701 J31-06
0803 J30-06

LOGIC CROSS REFERENCE INFORMATION

PUB		REV	
83324630		B	
CROSS REF NO	PAGE		
0420		1-98	

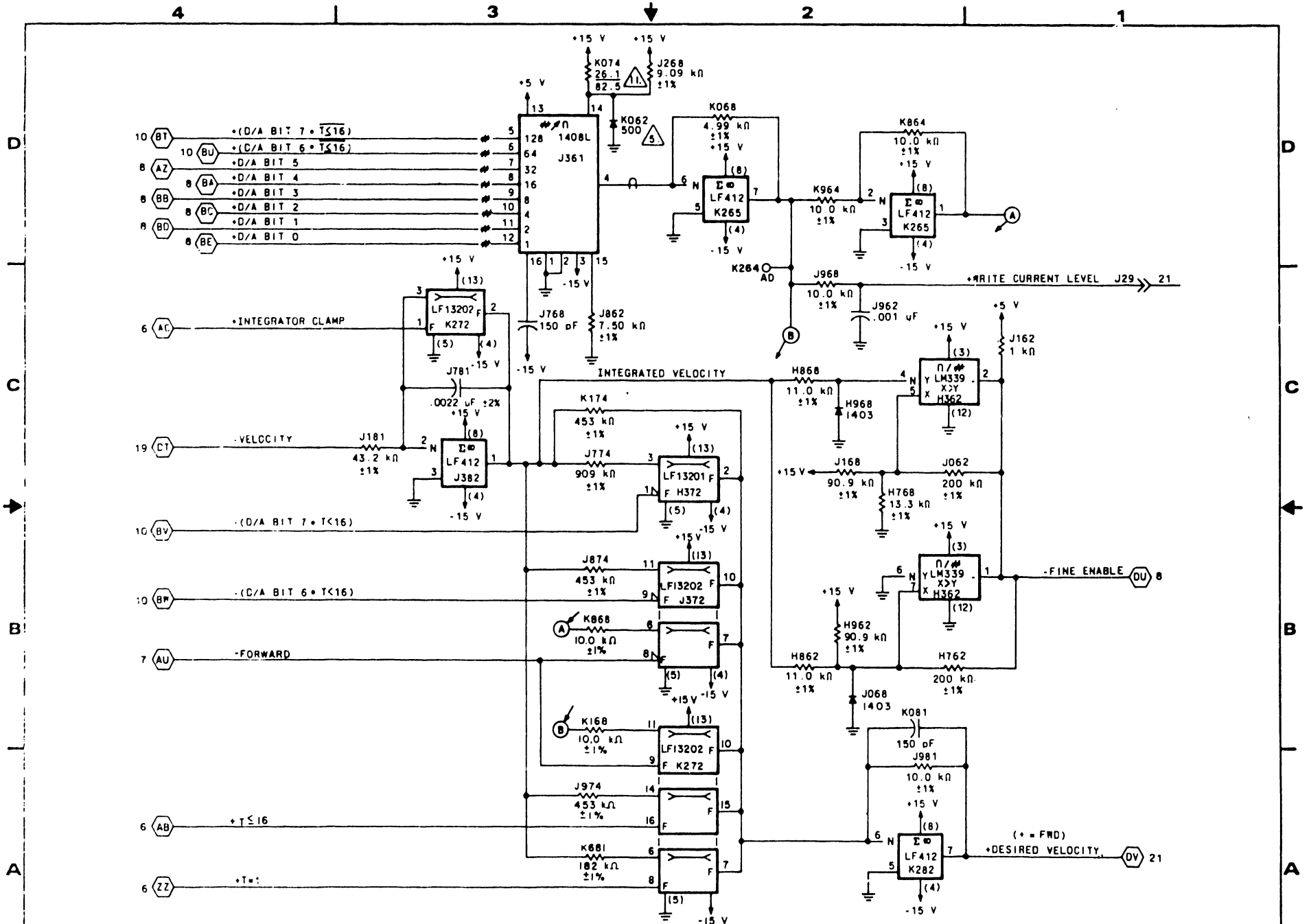

MAGNETIC PERIPHERALS INC <small>MEMBER OF CHRYSLER GROUP COMPANY</small>	DESIRED VELOCITY TYPE: _PEX		<small>SMALL DISK DIVISION</small> C	83324630	C
			<small>CODE IDENT</small> 19333	0420	<small>SHEET 20</small> 1-99

SIGNAL INPUTS

0502 P23-09 --09-->> J23

SIGNAL OUTPUTS

J23 -->> 11 0502 P23-11

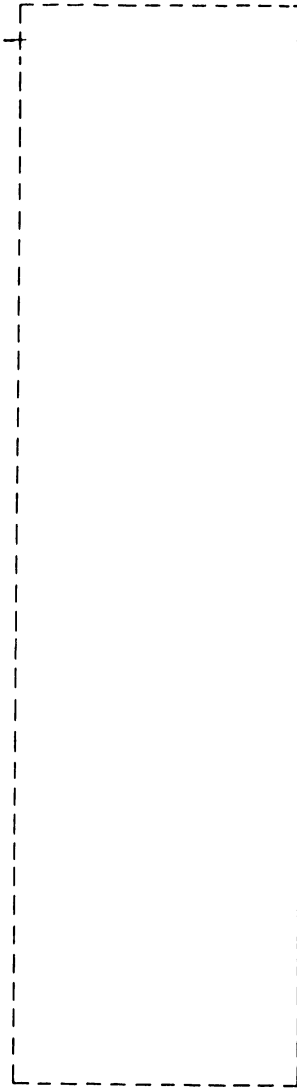

LOGIC CROSS REFERENCE INFORMATION

PUB	83324630	REV	B
CROSS REF NO	0421	PAGE	1-100

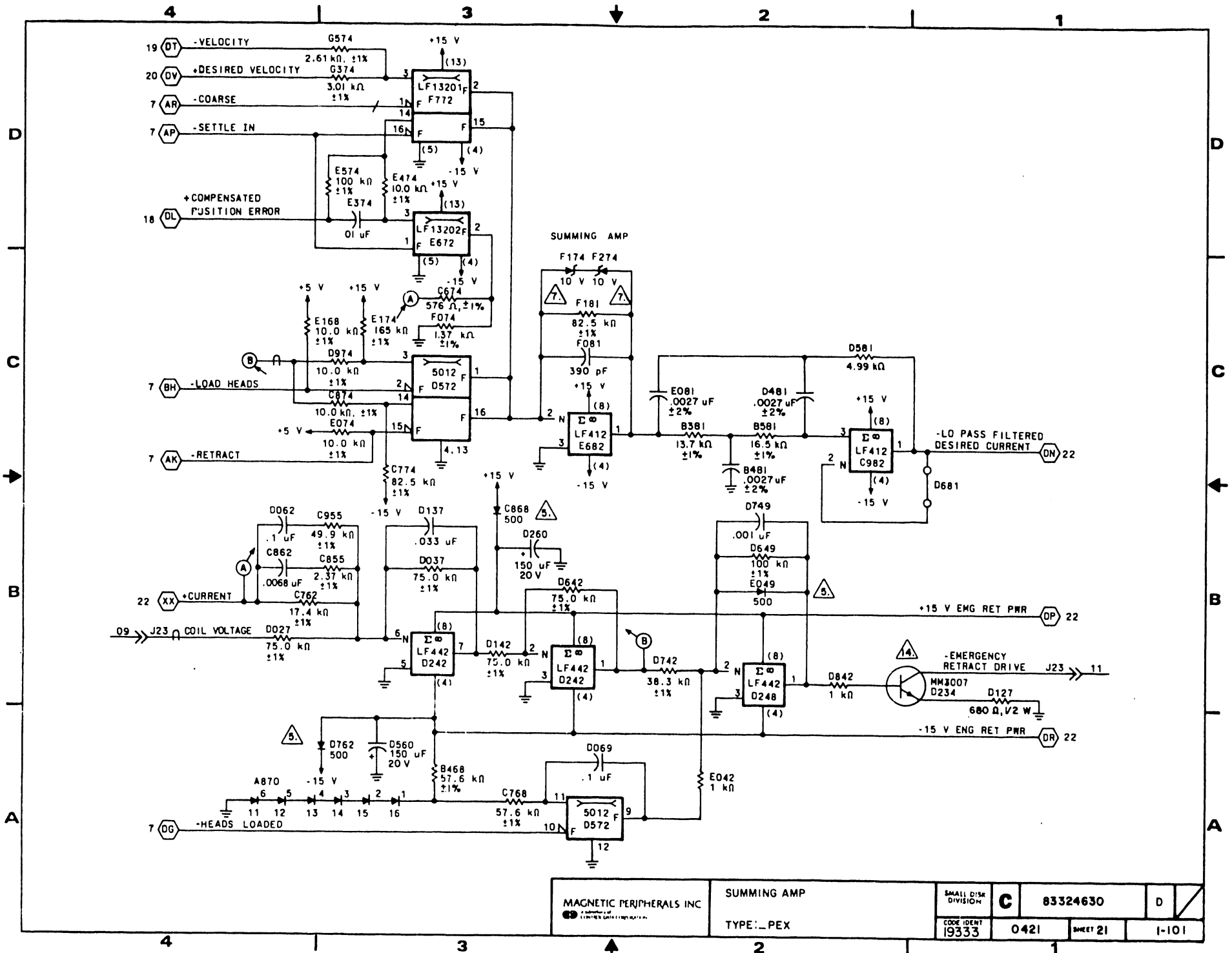

MAGNETIC PERIPHERALS INC CORPORATION	SUMMING AMP		SMALL DISK DIVISION	C	83324630	D
	TYPE: PEX		CODE IDENT 19333			

SIGNAL INPUTS

0502 P23-07 07 >> J23
0502 P23-05 05 >> J23

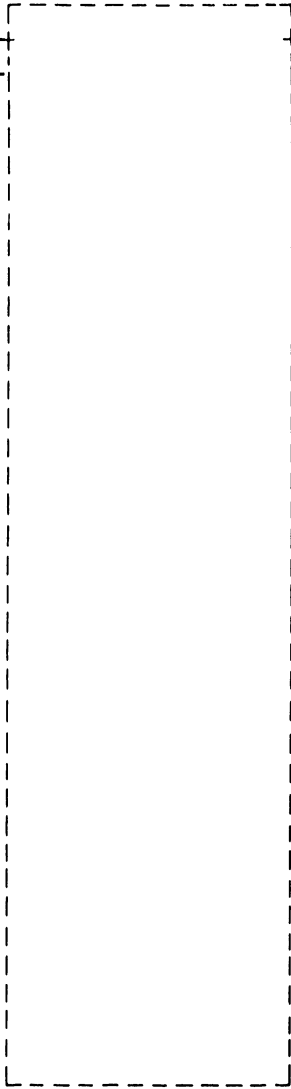

SIGNAL OUTPUTS

J23 >> 03 0502 P23-03
J23 >> 01 0502 P23-01

LOGIC CROSS REFERENCE INFORMATION

PUB		83324630	REV	B
CROSS REF NO	0422	PAGE	1-102	

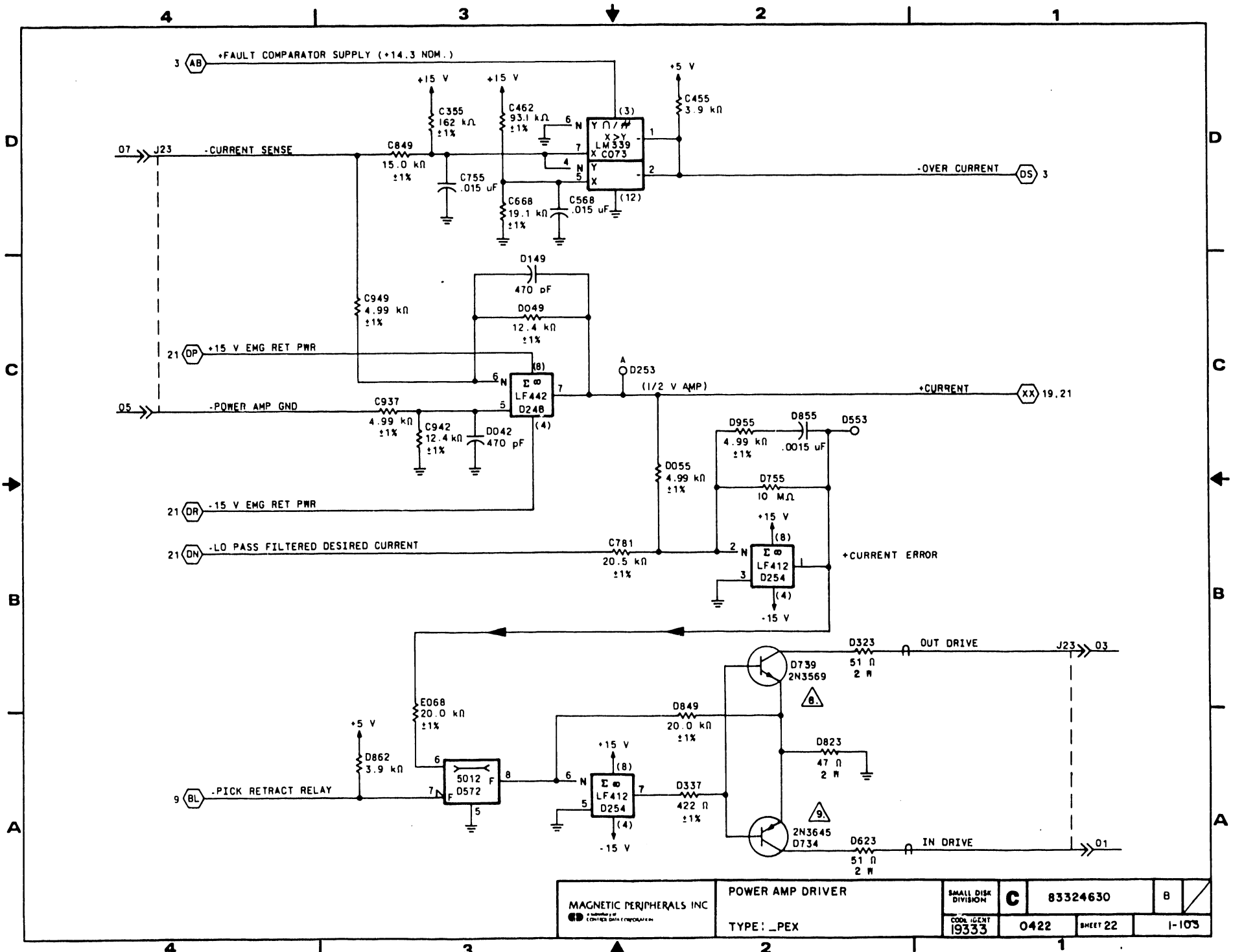

MAGNETIC PERIPHERALS INC A MEMBER OF CORNING DATA CORPORATION	POWER AMP DRIVER	SMALL DISK DIVISION	C	83324630	B
	TYPE: _PEX	COOL IDENT 19333	0422	SHEET 22	I-103

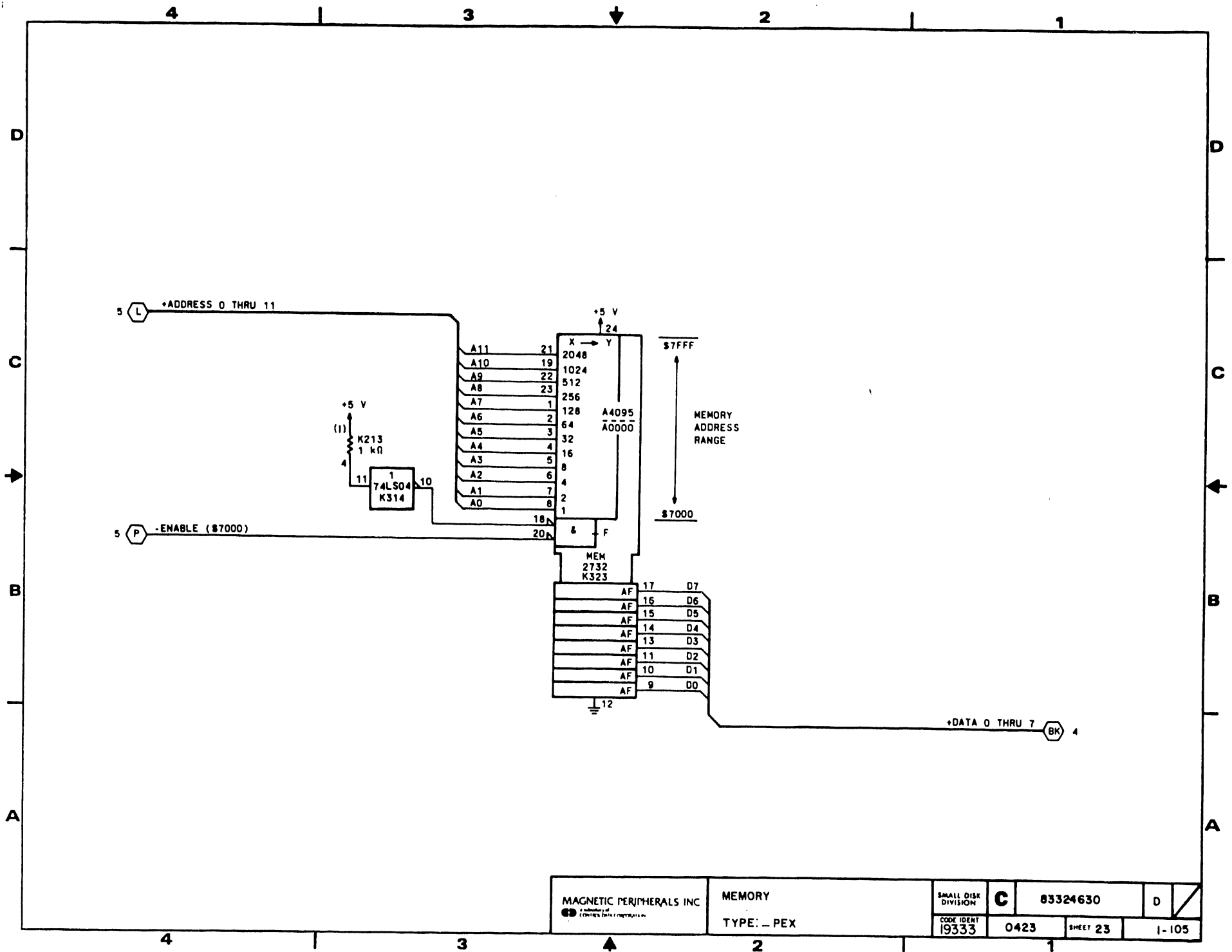

SIGNAL INPUTS

1002	J40-11	05	>>	J21
1002	J40-04	07	>>	J21
1002	J40-01	08	>>	J21
1002	J40-02	03	>>	J21
1002	J40-05	04	>>	J21
1002	J40-03	01	>>	J21
1002	J40-06	02	>>	J21
1002	J40-15	06	>>	J21

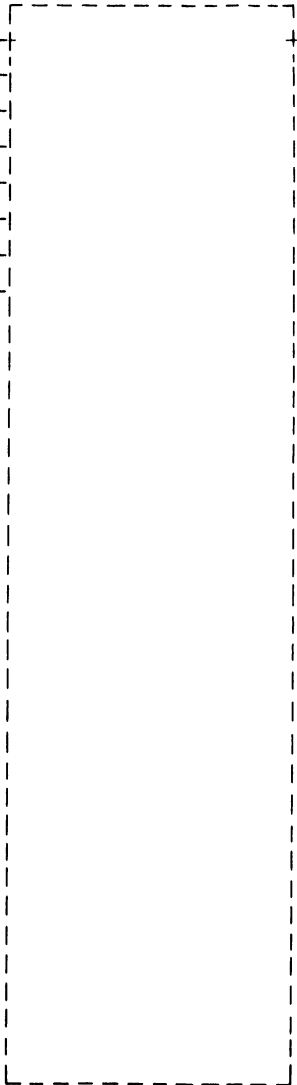

SIGNAL OUTPUTS

LOGIC CROSS REFERENCE INFORMATION

PUB	83324630	REV	D
CROSS REF NO	0401	PAGE	1-106

UNUSEC LOGIC ELEMENTS		
ELEMENT	LOCATION	OUTPUT PINS
10102	P127	14
LM393	M782	7
10125	E715	5, 12, 13
74LS10	E215	12
13202	E672	10
LM339	E662	1, 2
74LS20	E851	8
74LS00	L918	11
96LS02	L208	9, 10
7406	E224	8, 12
412	C982	7

UNUSED TRANSISTOR PACKS		
TYPE	LOCATION	PINS
MPQ3546	N356	5, 6, 7

UNUSED RESISTOR PACKS		
VALUE	LOCATION	PIN(S)
1 kΩ	N505	2, 8
1 kΩ	K213	2, 5

.1 uF			
+5 V	-5 V	+15 V	-15 V
J538	F115	C881	L556
E116	N008		K664
E615	M337	F681	N875
E625		H281	M868
E634	P520	J281	J762
E643	M527	K181	G174
E752	N027	M681	E062
G438	N827	N781	B462
G518	P527	M468	C481
H638	N737	P562	
H515	N010	B981	
J262		D155	
L150			
L737			
K252			
L827			
L814			
K229			
J911			
K710			
M320			
M408			
B562			

PART NO RANGE	REVISION RECORD						
	REV	ECO	DESCRIPTION	DEPT	DATE	CHKD	APP
02 THRU 02	A	01.12.00	RELEASED		11/13		
	B	DJ03288	LOGIC DIA CORR	SI	3/10/83	DSD	II
	C	DJ03347	ADD CHANGES	DN	5/24/83	DSD	II
	D	DJ03330	CHANGE WIRE VALUES	DN	5/24/83	DSD	II
	E	DJ03312	ADDED KEY	MT	7/24/83	CR	II
	F	DJ03441	CHG RESISTOR CAPX	NP	3/20/83		
	G	DJ03443	CHG SCH LABELING	NP	8-30-83		
	H	DJ03463	REPLAC CAPX WITH DPEX	MJ	10/14/83		

NOTES

- UNLESS OTHERWISE SPECIFIED
ALL 14 PIN IC'S HAVE PIN 7 CONNECTED TO GROUND.
ALL 16 PIN IC'S HAVE PIN 8 CONNECTED TO GROUND,
AND PIN 16 CONNECTED TO +5 V
ALL DIODES: 50241403
ALL DIODES: LED 94372500
ALL DIODE ARRAYS: D116, 50241801
ALL RESISTOR PACK RESISTORS: ±3%, 1/8 W.
ALL TRANSISTORS: SPNP, HM5005, 50222400
ALL TRANSISTOR ARRAYS: NPN, MPQ2369, 50213300
ALL ○—○ INDICATE MOLDED JUMPER WIRES.
- INPUT PINS OF UNUSED LOGIC ELEMENT 74LS20 TO GROUND.
- SEE TABLE FOR .1 uF FILTER CAP LOCATIONS.
- FOR EASE OF LOCATING WHICH PAGE A CONNECTOR PIN IS ON SEE PIN/SHEET CROSS REFERENCE DIAGRAMS ON SHEET 2.
- DIODE, SILICON, 24553500
- DIODE, SILICON, 1N4001, 95637301
- DIODE, SILICON, 1CV, 50240113
- TRANSISTOR, SPNP, 2N3569, 50210801
- TRANSISTOR, SPNP, 2N3645, 50211200
- TRANSISTOR ARRAY, MPQ3546, 15165619
- TEST SELECT RESISTORS TO BE SELECTED FROM DRAWING 94357500 AND INSERTED DURING CARD TEST PER CARD TEST REQUIREMENTS.

△3 DELAY TIME FOR REFERENCE ONLY.

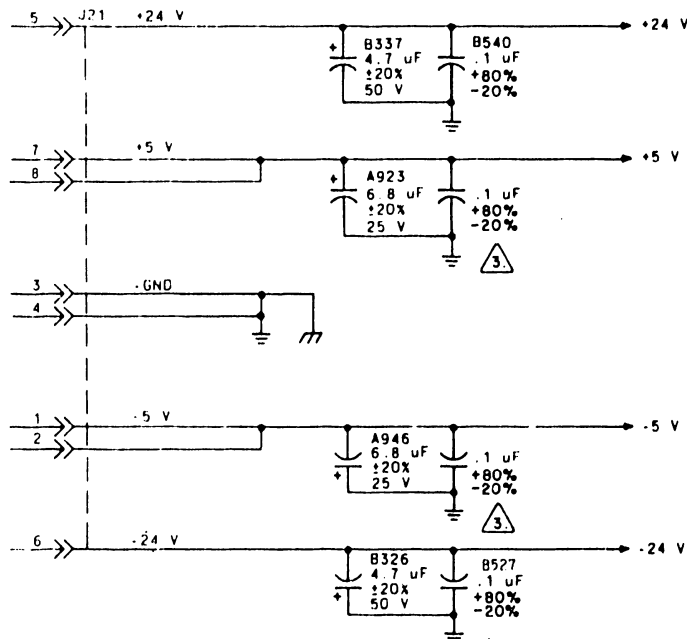

REFERENCE DRAWING			MAGNETIC PERIPHERALS INC		TITLE	
COMP ASSY 54332102			CD		SCHEMATIC DIAGRAM	
CTR 64332302			FIRST USED ON		RSD CONTROL BOARD	
			NEXT ASSEMBLY		TYPE DPEX	
COMPONENTS EXCEPT AS NOTED			DWN	F. A.	11/18/82	REV
TOLERANCE	VALUE	RATING	CHKD	DGD	12/15/81	
RES	±5%	OHMS	1/4 W	ENGR	12-20-77	
CAP	±10%			MFG		
				QA	2-3-83	
SCALE					0401	CODE IDENT 19333
REF: B4332203					1	PRODUCT RSD

B54332202

SIGNAL INPUTS

0102 P26-11 11 >> J26

SIGNAL OUTPUTS

J23 >> 02	0502 P23-02
J23 >> 04	0502 P23-04
J23 >> 06	0502 P23-06
J23 >> 08	0502 P23-08
J23 >> 10	0502 P23-10
J23 >> 12	0502 P23-12
J23 >> 14	0502 P23-14
J24 >> 02	0601 P24-02
J24 >> 04	0601 P24-04
J24 >> 08	0601 P24-08
J24 >> 10	0601 P24-10
J24 >> 12	0601 P24-12
J24 >> 14	0601 P24-14
J25 >> 04	1042 P25-04
J25 >> 01	1042 P25-01
J25 >> 10	1042 P25-10
J26 >> 02	0101 P26-02
J26 >> 04	0101 P26-04
J26 >> 01	0101 P26-01
J26 >> 06	0101 P26-06
J28 >> 06	0301 J34-02
J29 >> 03	0801 J30-24
J29 >> 04	0701 J31-24
J29 >> 01	0801 J30-23
J29 >> 01	0701 J31-23
J29 >> 02	0801 J30-26
J29 >> 02	0701 J31-26
J29 >> 12	0801 J30-25
J29 >> 12	0701 J31-25
J29 >> 15	0801 J30-15
J29 >> 15	0701 J31-15
J29 >> 15	0801 J30-12
J29 >> 15	0701 J31-12

LOGIC CROSS REFERENCE INFORMATION

PUB	83324630	REV	D
CROSS REF NO	0402	PAGE	1-106.2

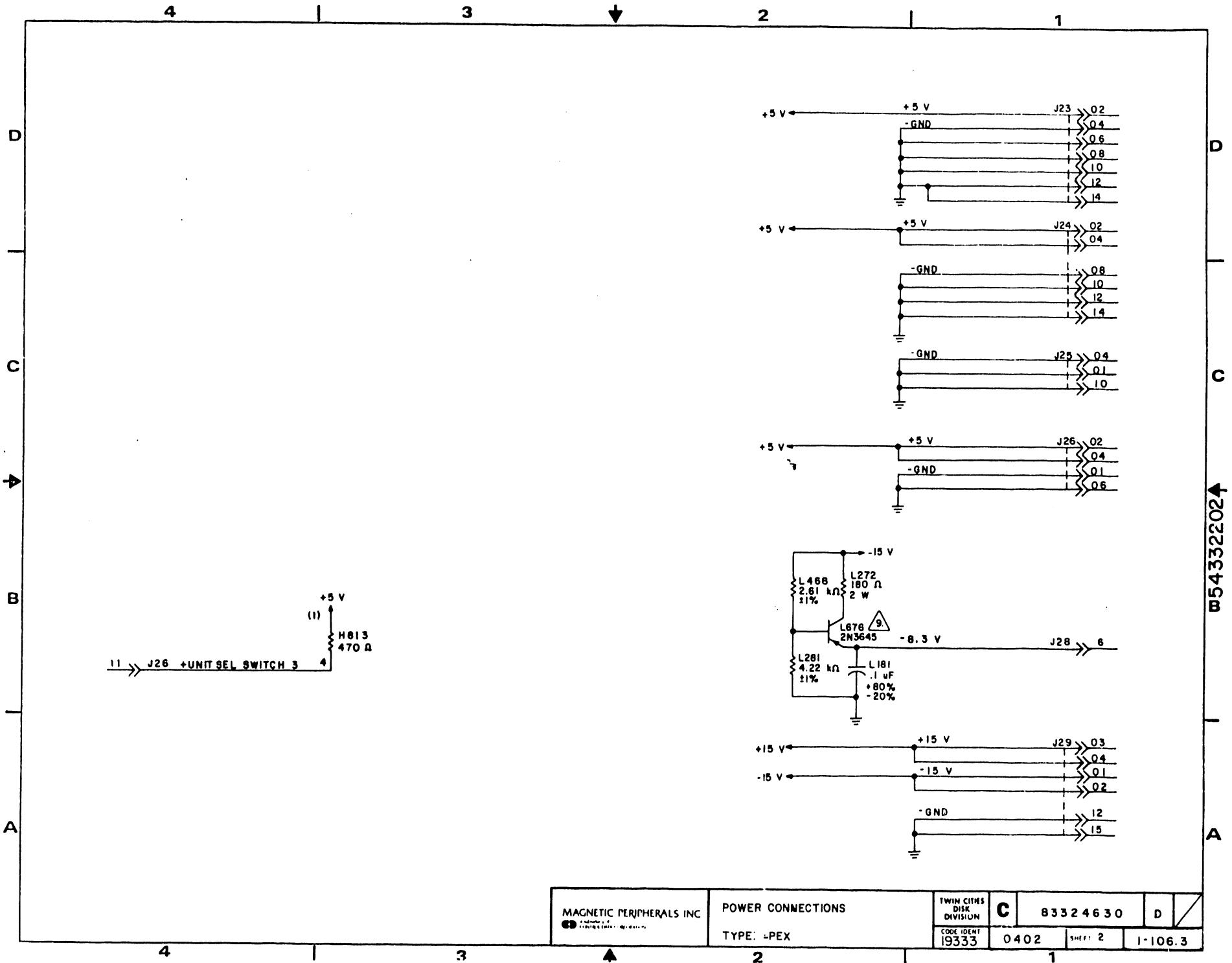

MAGNETIC PERIPHERALS INC CORPORATION	POWER CONNECTIONS		TWIN CITIES DISK DIVISION	C	83324630	D
	TYPE: LPEX		CODE IDENT 19333			

SIGNAL INPUTS

SIGNAL OUTPUTS

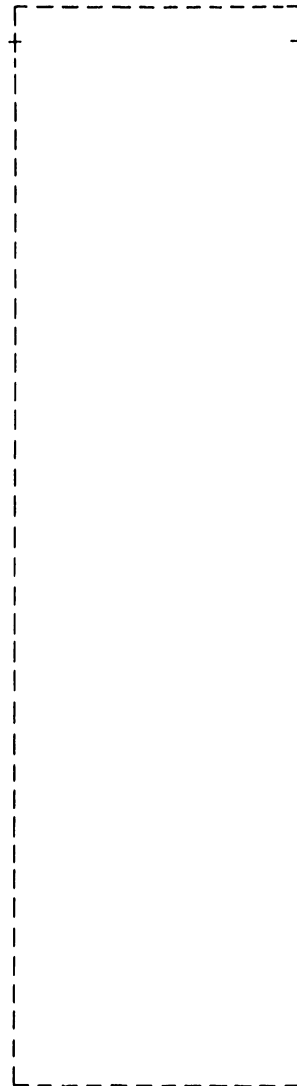

J14 >> 29

<u>SINGLE CHANNEL UNITS</u>		<u>DUAL CHANNEL UNITS</u>	
0206	J20-18	0212	J20-23

LOGIC CROSS REFERENCE INFORMATION

PUB		REV	
83324630		D	
CROSS REF NO		PAGE	
0403		1-106.4	

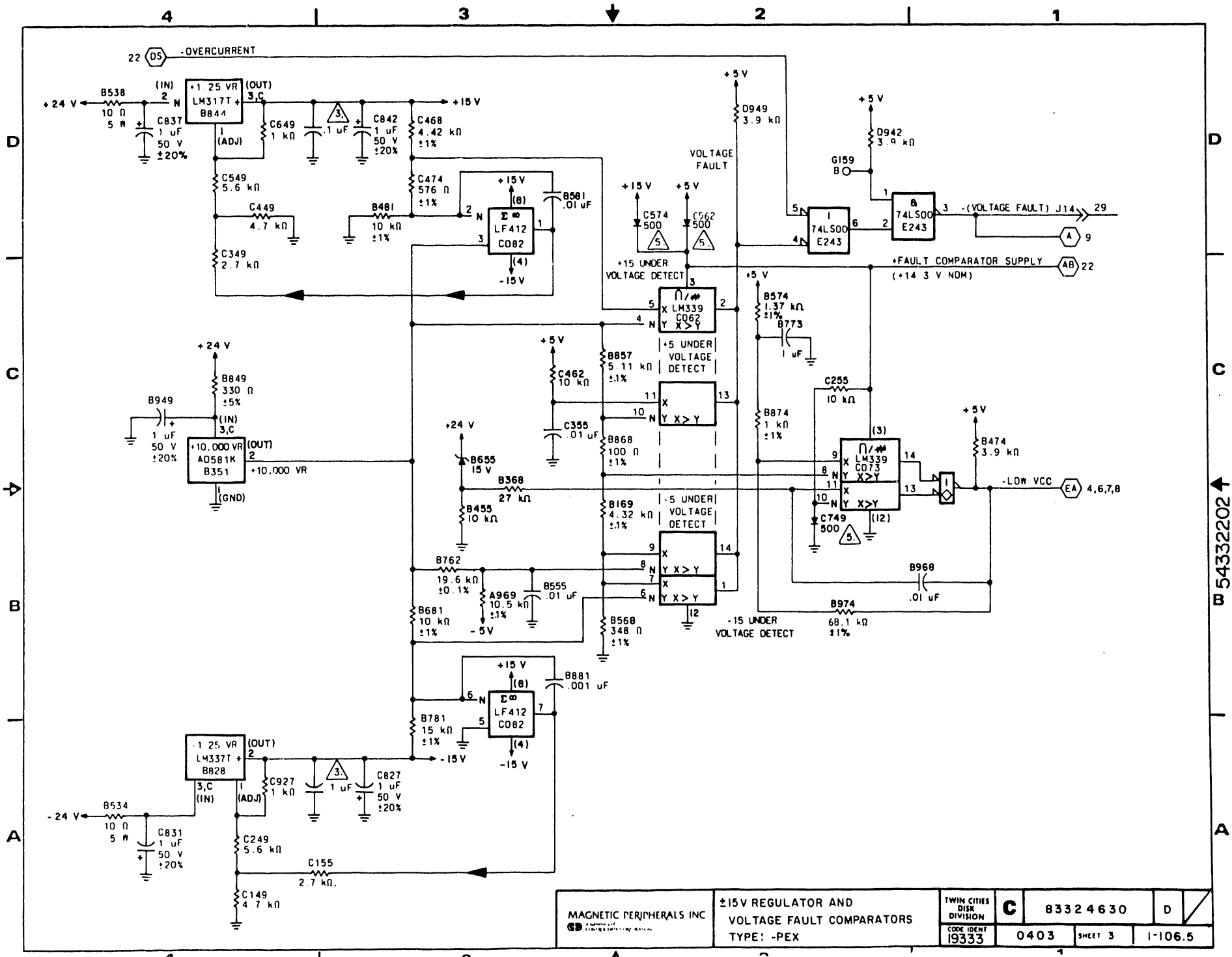

MAGNETIC PERIPHERALS INC GD	±15V REGULATOR AND VOLTAGE FAULT COMPARATORS TYPE: -PEX		TWIN CITIES DISK DIVISION	C	83324630	D
	CODE IDENT 19333	0403	SHEET 3			

B 54332202

SIGNAL INPUTS

SIGNAL OUTPUTS

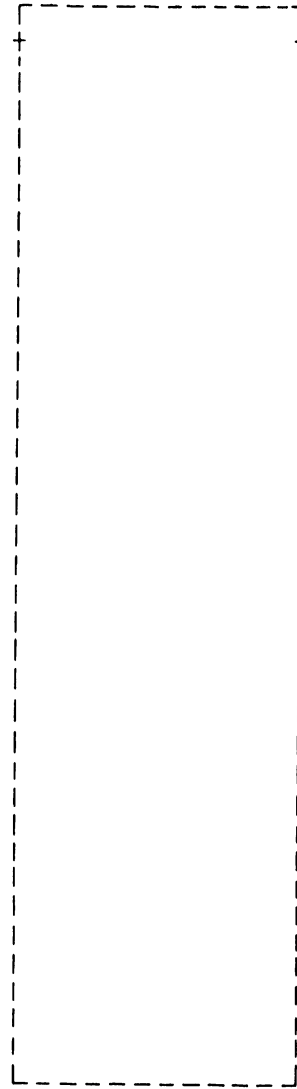

		<u>SINGLE</u>		<u>DUAL</u>	
		<u>CHANNEL UNITS</u>		<u>CHANNEL UNITS</u>	
J14	>> 21	0206	J20-02	0210	J20-39
J24	>> 05	0602	P24-05	0602	P24-05

LOGIC CROSS REFERENCE INFORMATION

PUB	83324630	REV	D
CROSS REF NO	0404	PAGE	1-106.6

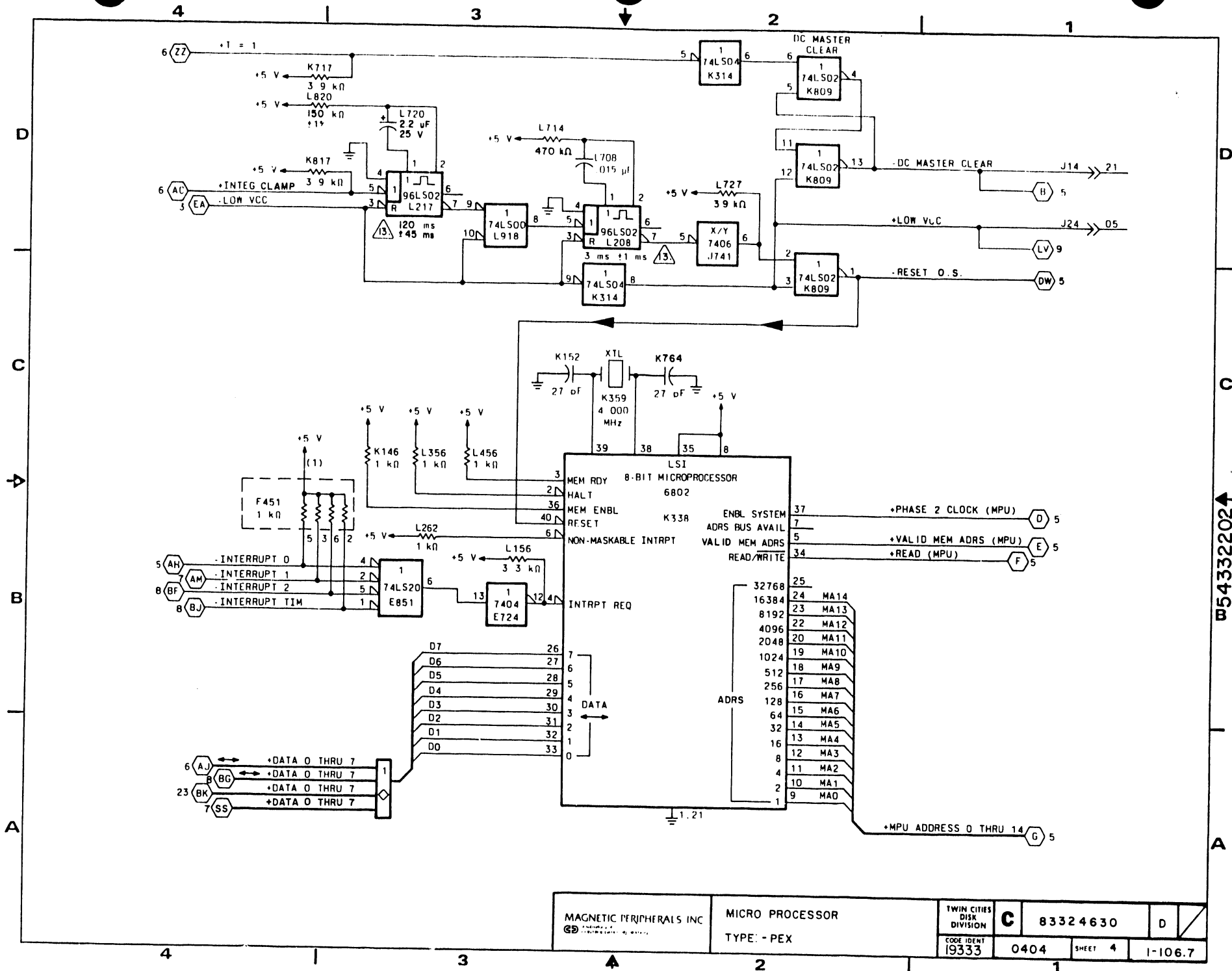

B543322024

MAGNETIC PERIPHERALS INC GD	MICRO PROCESSOR TYPE: - PEX	TWIN CITIES DISK DIVISION	C	83324630	D
		CODE IDENT 19333			

SIGNAL INPUTS

<u>SINGLE CHANNEL UNITS</u>		<u>DUAL CHANNEL UNITS</u>			
0202	J20-11	0202	J20-30	15	J14
0202	J20-05	0202	J20-36	18	J14
0202	J20-07	0202	J20-34	17	J14
0202	J20-13	0202	J20-28	14	J14
0202	J20-15	0202	J20-26	13	J14
0202	J20-19	0202	J20-22	11	J14
0102	P26-05	0102	P26-05	05	J26
0102	P26-03	0102	P26-03	03	J26
0102	P26-09	0102	P26-09	09	J26



SIGNAL OUTPUTS

<u>SINGLE CHANNEL UNITS</u>		<u>DUAL CHANNEL UNITS</u>	
J26	07	0102	P26-07
J14	10	0202	J20-21
J14	22	NC	J20-04
J14	32	NC	J20-24
J14	07	NC	J20-27
J14	06	NC	J20-29
		0210	P26-07
		0210	J20-20
		0204	J20-37
		0210	J20-17
		0210	J20-14
		0210	J20-12

LOGIC CROSS REFERENCE INFORMATION

PUB	83324630	REV	D
CROSS REF NO	0405	PAGE	1-106.8

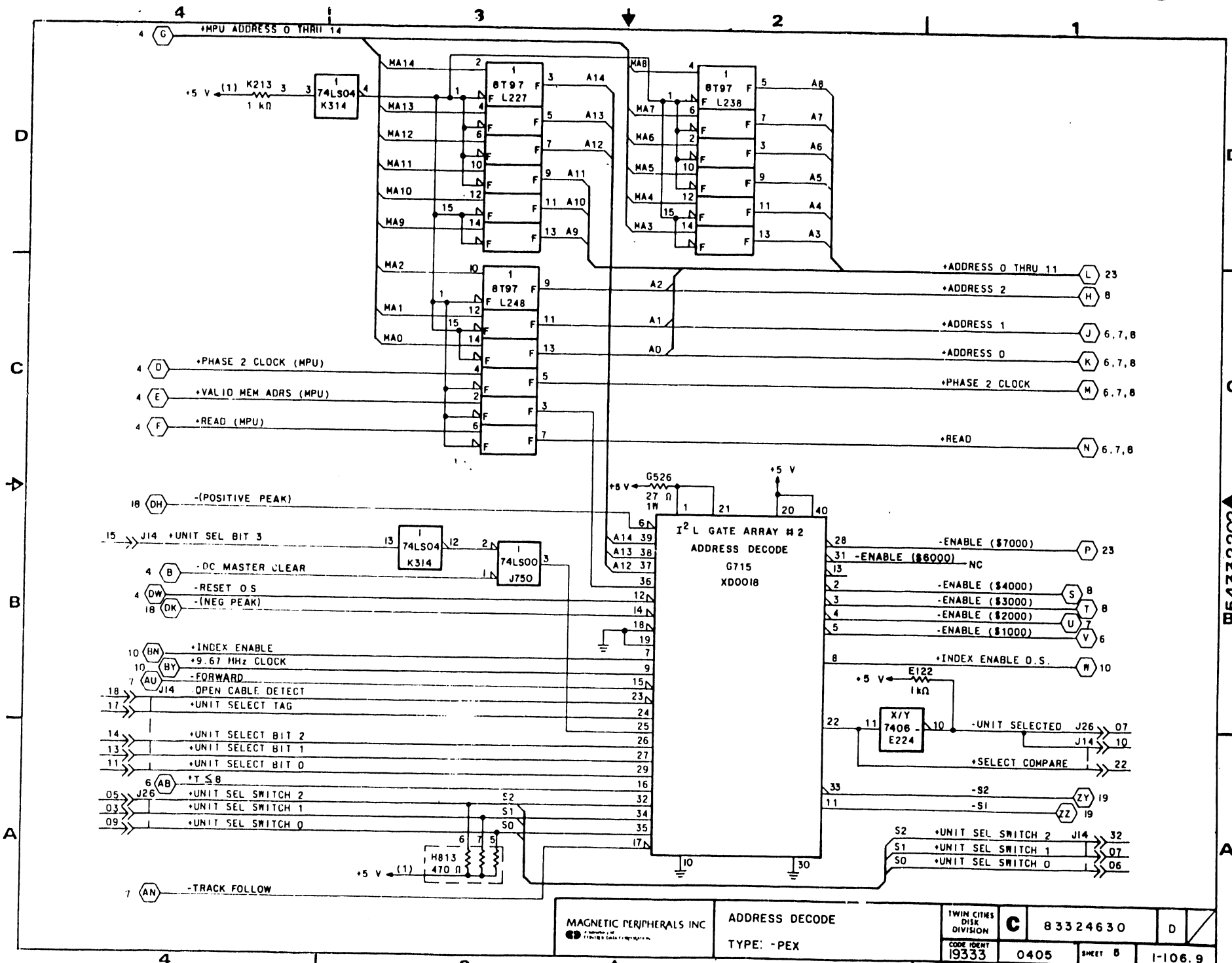

543322024

MAGNETIC PERIPHERALS INC <small>© TWIN CITIES DISK DIVISION</small>	ADDRESS DECODE		TWIN CITIES DISK DIVISION	C	8 3 3 2 4 6 3 0	D
	TYPE: -PEX		CODE IDENT 19333			

SIGNAL INPUTS

SINGLE CHANNEL UNITS		DUAL CHANNEL UNITS			
0206	J20-26	0212	J20-15	33	>> J14
0206	J20-39	0212	J20-02	01	>> J14
0206	J20-28	0212	J20-13	34	>> J14
0206	J20-10	0212	J20-31	25	>> J14
1042	P25-05	1042	P25-05	05	>> J25
0206	J20-37	0212	J20-04	02	>> J14
0206	J20-35	0212	J20-06	03	>> J14
0206	J20-33	0212	J20-08	04	>> J14
0206	J20-31	0212	J20-10	05	>> J14

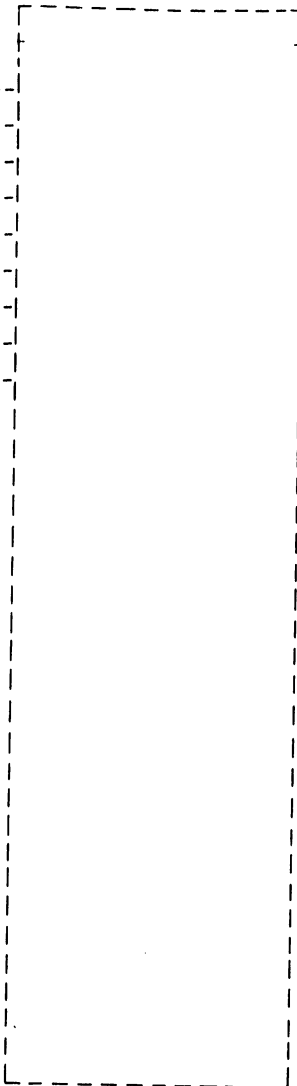

SIGNAL OUTPUTS

SINGLE CHANNEL UNITS		DUAL CHANNEL UNITS			
0206	J20-25	0212	J20-16	J14	>> 08
0206	J20-23	0212	J20-18	J14	>> 09
0204	J20-17	0204	J20-24	J14	>> 12
0701	J31-07	0701	J31-07	J29	>> 20
0805	J30-07	0805	J30-07	J29	>> 22
0701	J31-05	0701	J31-05	J29	>> 24
0805	J30-05	0805	J30-05	J29	>> 24
0701	J31-03	0701	J31-03	J29	>> 26
0805	J30-03	0805	J30-03	J29	>> 26
0701	J31-01	0701	J31-01	J29	>> 26
0805	J30-01	0805	J30-01	J29	>> 26

LOGIC CROSS REFERENCE INFORMATION

PUB		REV	
83324630		D	
CROSS REF NO	PAGE		
0406	1-106.10		

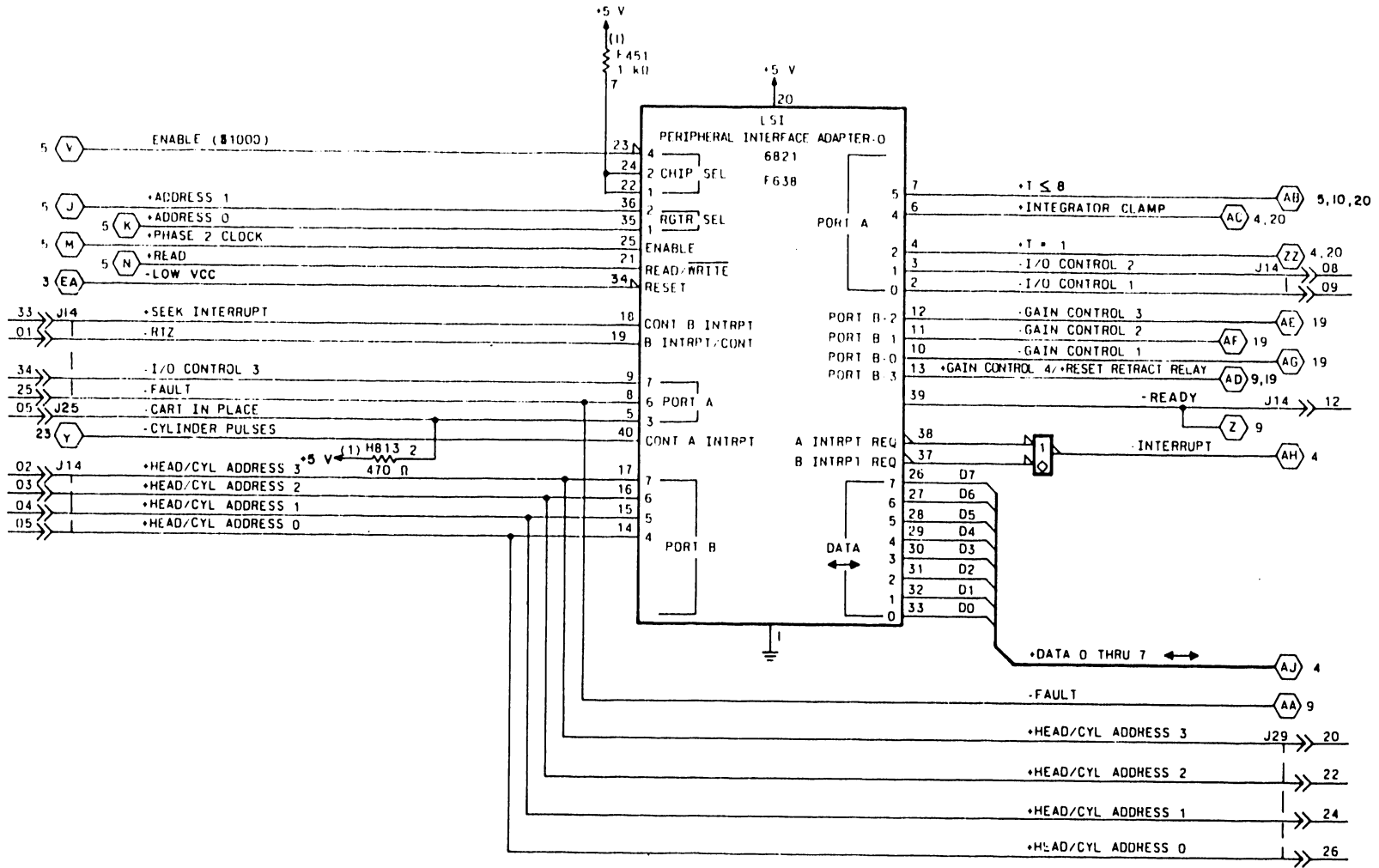

B54332202

SIGNAL INPUTS

SINGLE CHANNEL UNITS		DUAL CHANNEL UNITS			
1042	P25-08	1042	P25-08	08	J25
1042	P25-02	1042	P25-02	02	J25
0102	P26-08	0102	P26-08	08	J26
0205	J20-20	0205	J20-21	30	J14
NC	J20-16	NC	J20-25	28	J14

SIGNAL OUTPUTS

J24 --->> 11 0602 P24-11

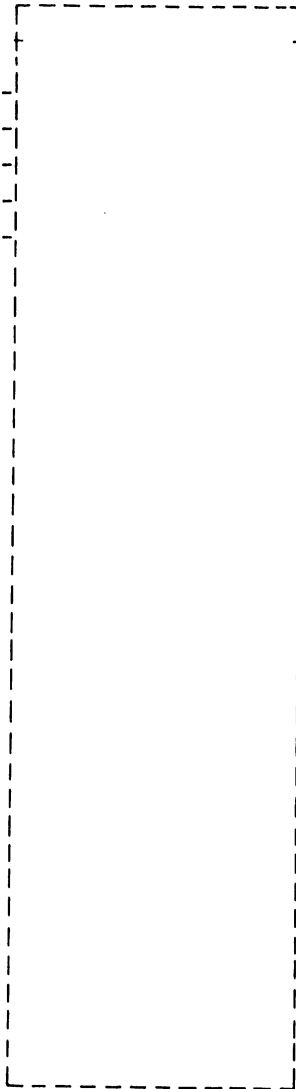

LOGIC CROSS REFERENCE INFORMATION

PUB	83324630	REV	D
CROSS REF NO	0407	PAGE	1-106.12

4

3

2

1

D

D

C

C

B

B

A

A

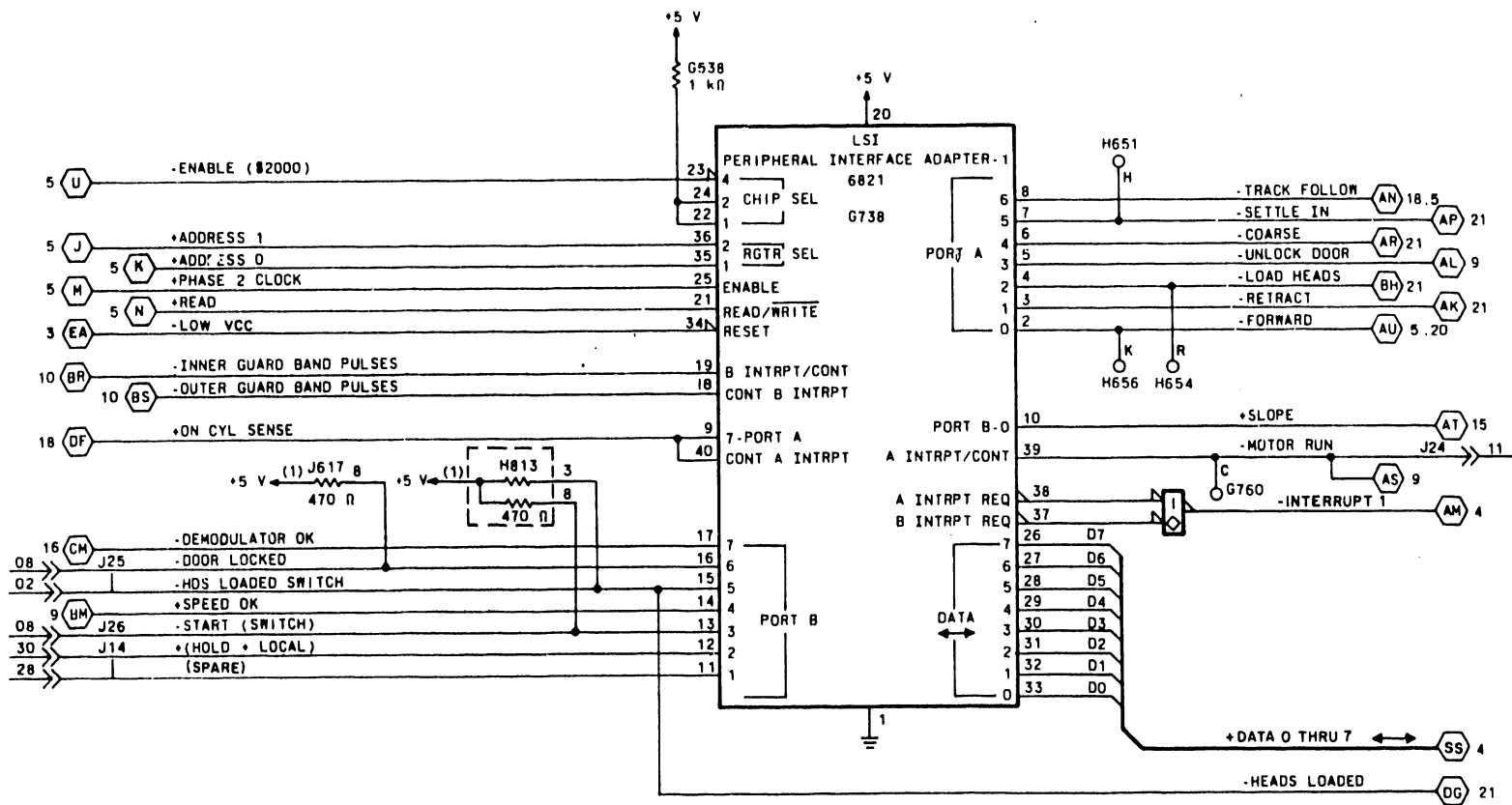

54332202

MAGNETIC PERIPHERALS INC CORPORATION	PIA 0 AND PIA 1	TWIN CITIES DISK DIVISION	C	83324630	D
	TYPE: - PEX	CODE IDENT 19333			

SIGNAL INPUTS

0602	P24-09	09	>>	J24
0102	P26-10	10	>>	J26
0602	P24-07	07	>>	J24

SIGNAL OUTPUTS

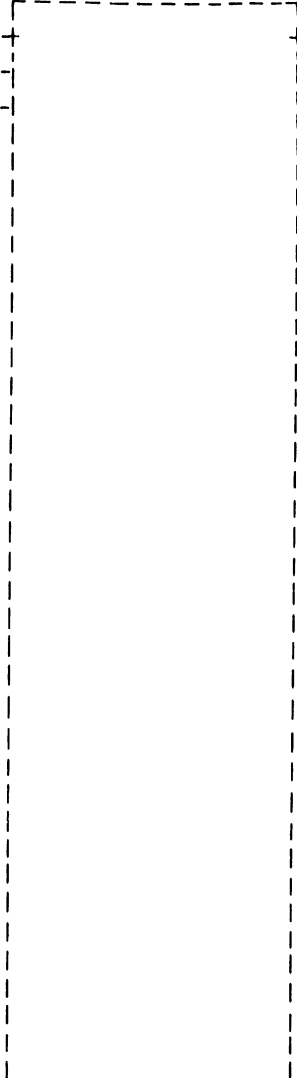

LOGIC CROSS REFERENCE INFORMATION

PUB	83324630	REV	D
CROSS REF NO	0408	PAGE	1-106.14

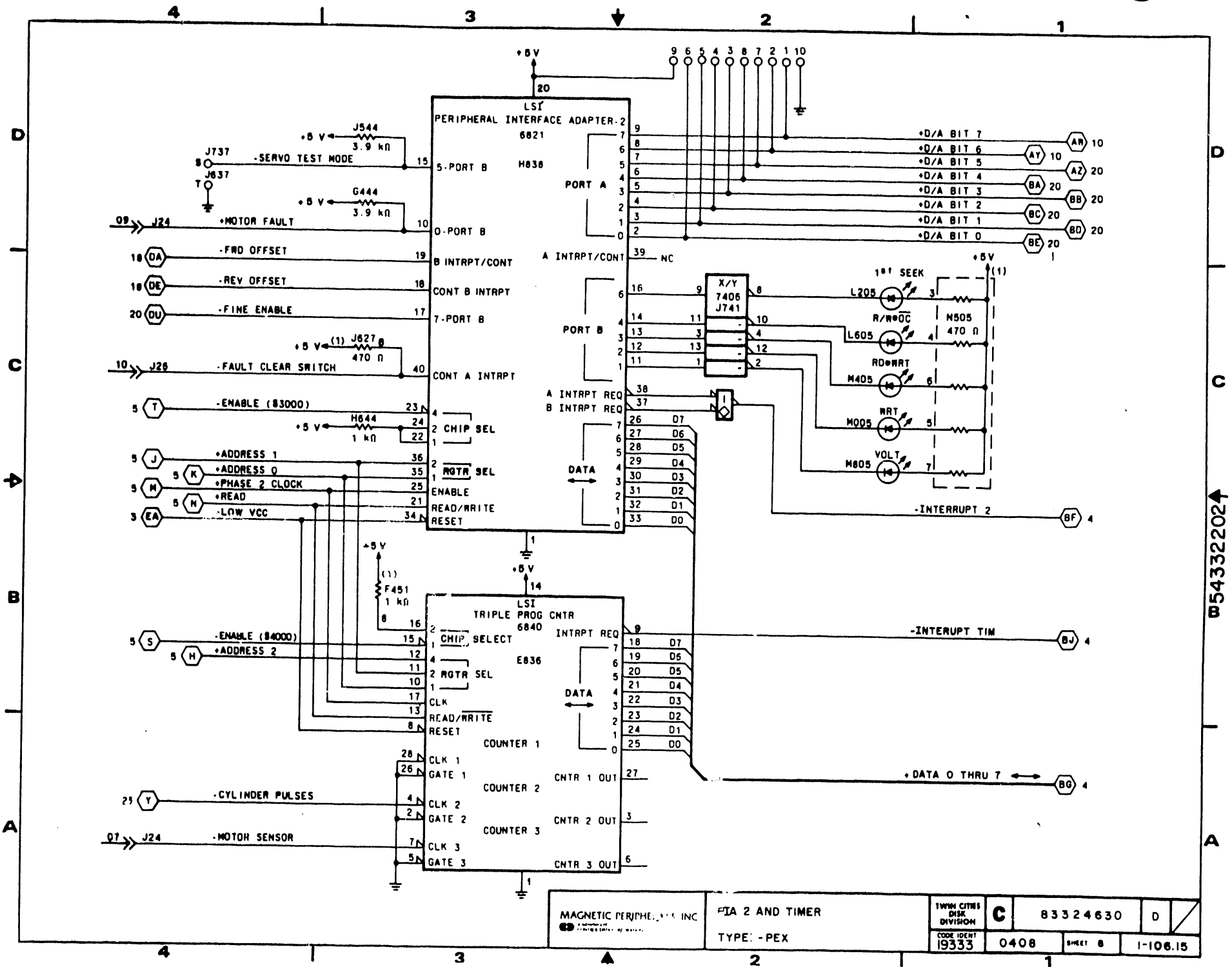

W543322024

SIGNAL INPUTS

SINGLE CHANNEL UNITS		DUAL CHANNEL UNITS			
0603	P24-03	0603	P24-03	03	J24
0602	P24-01	0602	P24-01	01	J24
0206	J20-12	0212	J20-29	26	J14
1042	O25-03	1042	P25-03	03	J25

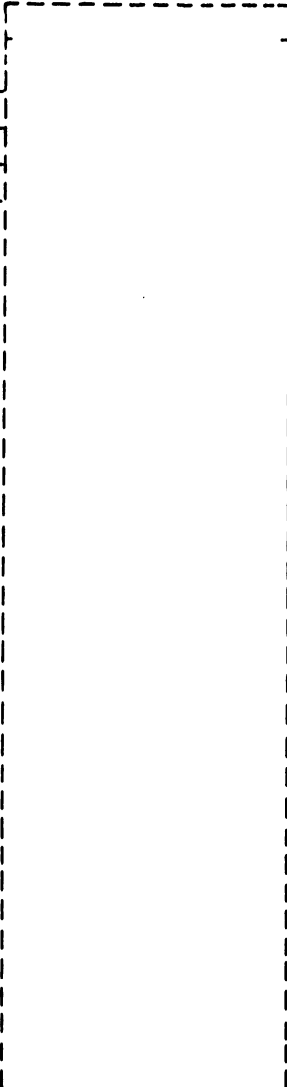

SIGNAL OUTPUTS

SINGLE CHANNEL UNITS		DUAL CHANNEL UNITS			
				J23	13
				J26	13
				J25	06
				J25	07
				J24	06
				J14	31
				J29	09
				J14	24
				J26	14
				J26	12
0502	P23-13	0502	P23-13		
0102	P26-13	0102	P26-13		
1042	P25-06	1042	P25-06		
1042	P25-07	1042	P25-07		
0602	P24-06	0602	P24-06		
0206	J20-22	0212	J20-19		
0802	J30-18	0802	J30-18		
0204	J20-08	0204	J20-33		
0102	P26-14	0102	P26-14		
0102	P26-12	0102	P26-12		

LOGIC CROSS REFERENCE INFORMATION

PUB		REV	
83324630		D	
CROSS REF NO		PAGE	
0409		1-106.16	

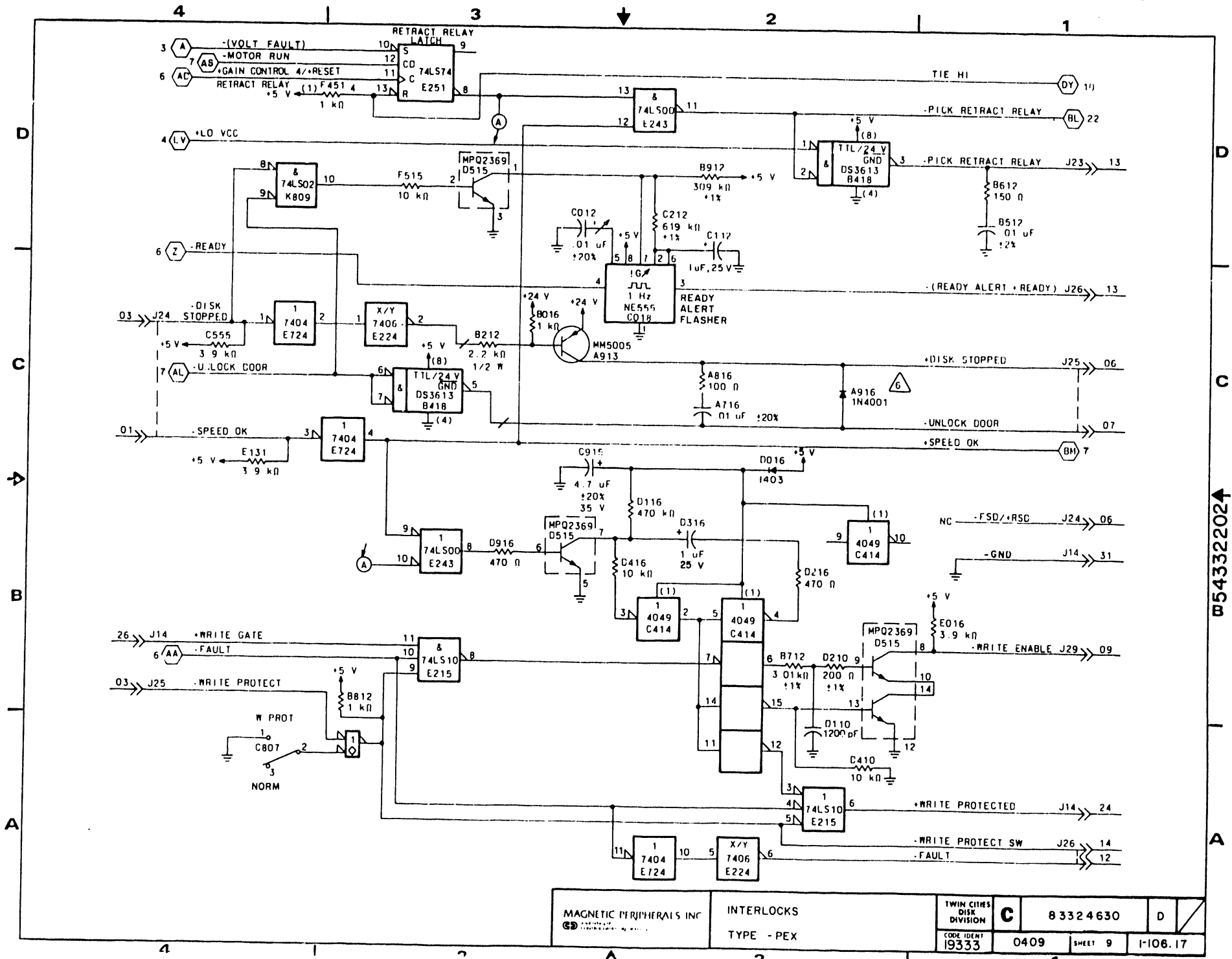

W543322024

MAGNETIC PERIPHERALS INC G.D. COMPANY	INTERLOCKS		TWIN CITIES DIVISION	C	8 332 4 630	D
	TYPE - PEX		CODE IDENT 19333	0409	SHEET 9	I-106.17

SIGNAL INPUTS

SINGLE CHANNEL UNITS		DUAL CHANNEL UNITS			
0206	J20-33	0212	J20-38	19	J14
0206	J20-06	0212	J20-35	23	J14
0703	J31-13	0703	J31-13	14	J29
0703	J31-14	0703	J31-14	13	J29
1042	P25-09	1042	P25-09	09	J25

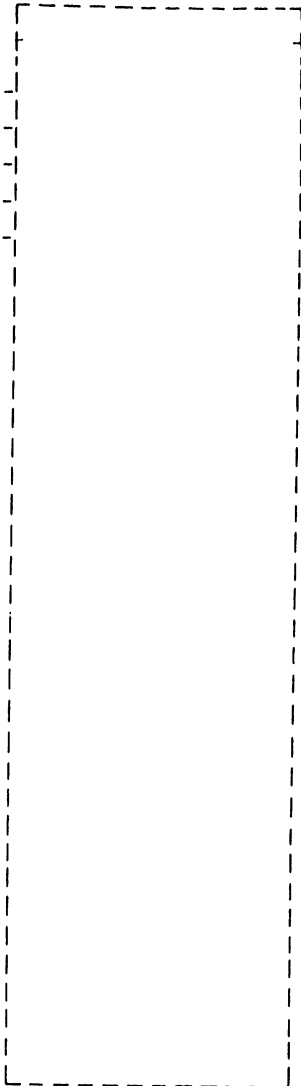

SIGNAL OUTPUTS

SINGLE CHANNEL UNITS		DUAL CHANNEL UNITS	
J14	>> 20	0204	J20-01
J14	>> 16	0205	J20-09
J14	>> 35	0204	J20-30
J24	>> 13	0603	P24-13

LOGIC CROSS REFERENCE INFORMATION

PUB	83324630	REV	D
CROSS REF NO	0410	PAGE	1-106.18

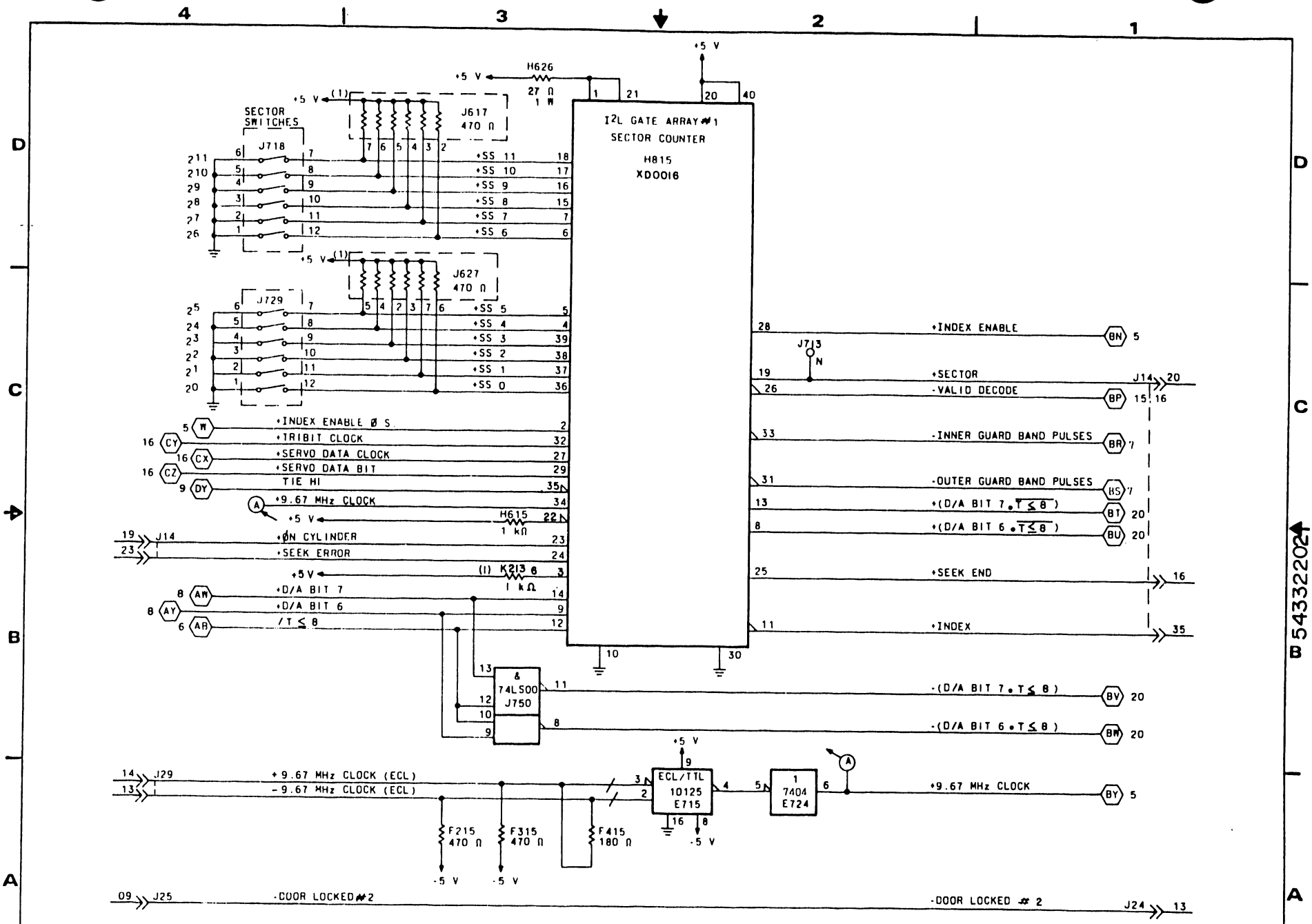

MAGNETIC PERIPHERALS INC 6B	SECTOR COUNTER TYPE: - PEX	TWIN CITIES DISK DIVISION	C	83324630	D
		CODE IDENT 19333			

B 54332202A

SIGNAL INPUTS

0302	J34-04	04	>>	J28
0301	J34-01	01	>>	J28
0301	J34-03	03	>>	J28
0301	J34-05	05	>>	J28
0302	J34-06	02	>>	J28

SIGNAL OUTPUTS

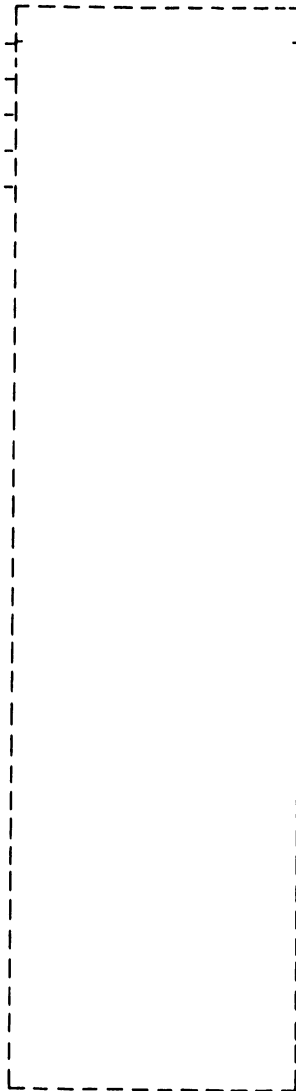

LOGIC CROSS REFERENCE INFORMATION

PUB	83324630	REV	D
CROSS REF NO	0411	PAGE	1-106.20

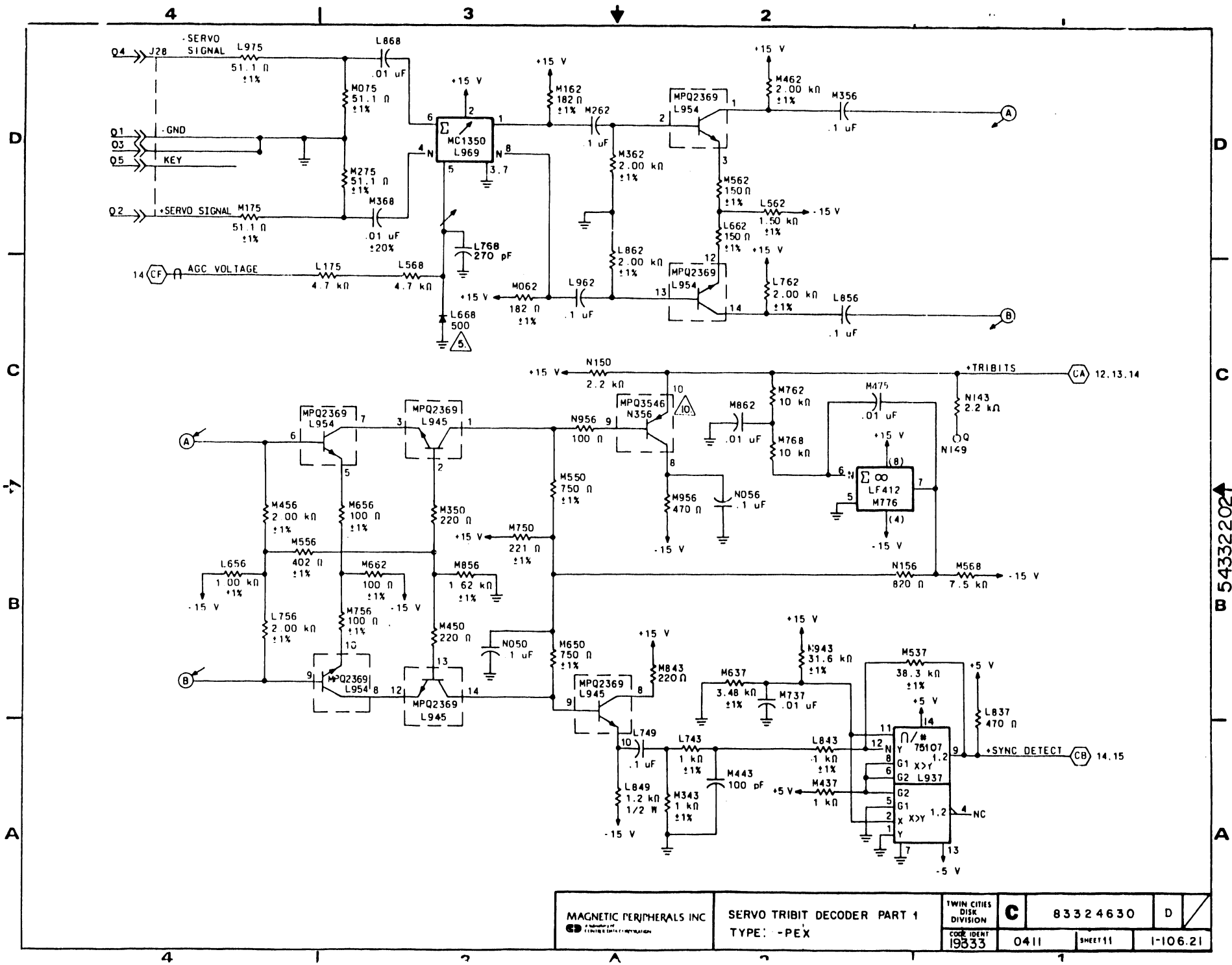

MAGNETIC PERIPHERALS INC. A DIVISION OF GENERAL ELECTRIC	SERVO TRIBIT DECODER PART 1 TYPE: -PEX	TWIN CITIES DISK DIVISION	C	83324630	D
		CODE IDENT 19833			

B 54332202A

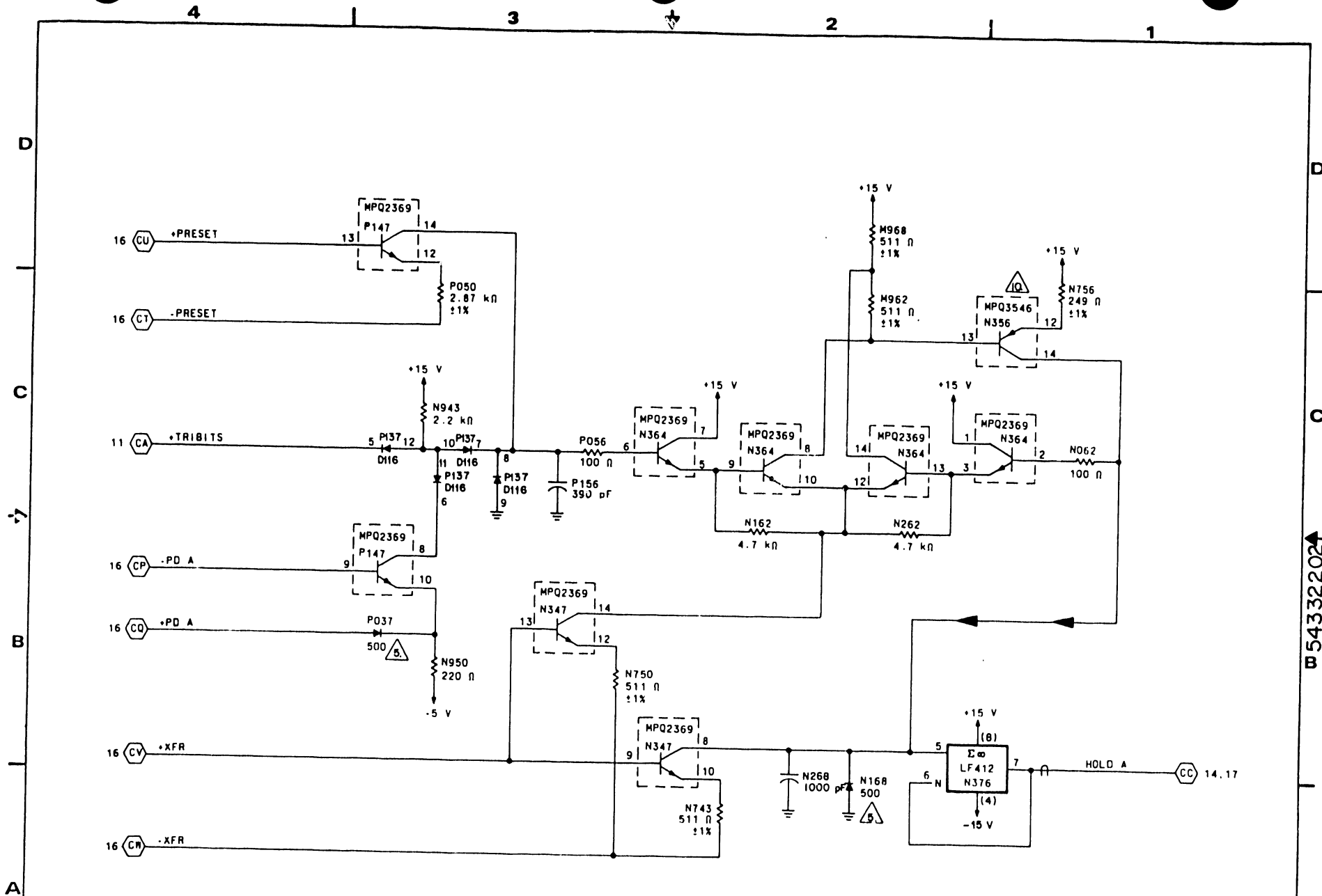

543322021

MAGNETIC PERIPHERALS INC SERVO TRIBIT DECODER PART 2 TYPE: -PE X	TWIN CITIES DISK DIVISION	C	83324630	D
	CODE IDENT 19333			

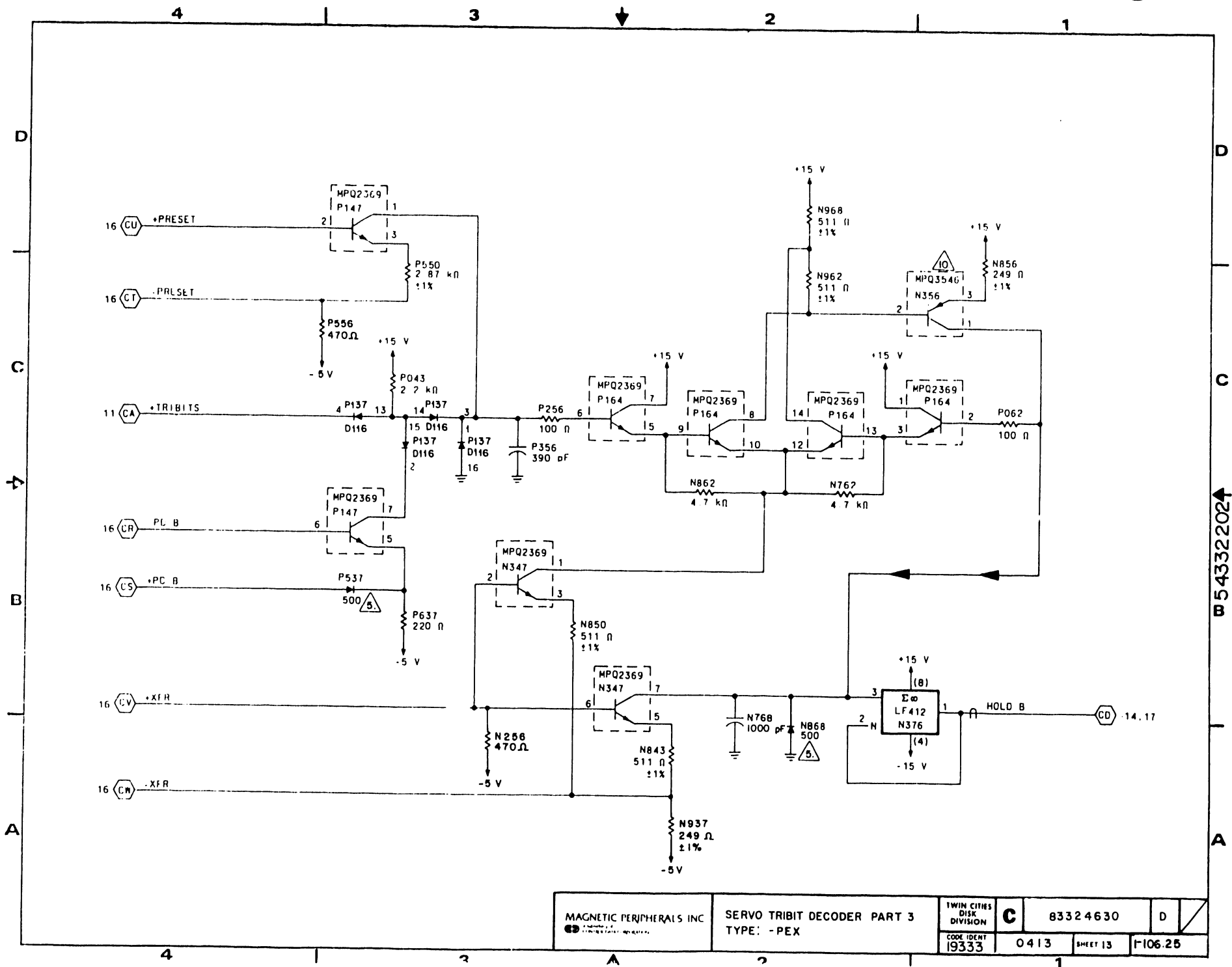

MAGNETIC PERIPHERALS INC SERVO TRIBIT DECODER PART 3 TYPE: -PEX	TWIN CITIES DISK DIVISION	C	83324630	D
	CODE IDENT I9333			

B 54332 2021

SIGNAL INPUTS

SIGNAL OUTPUTS

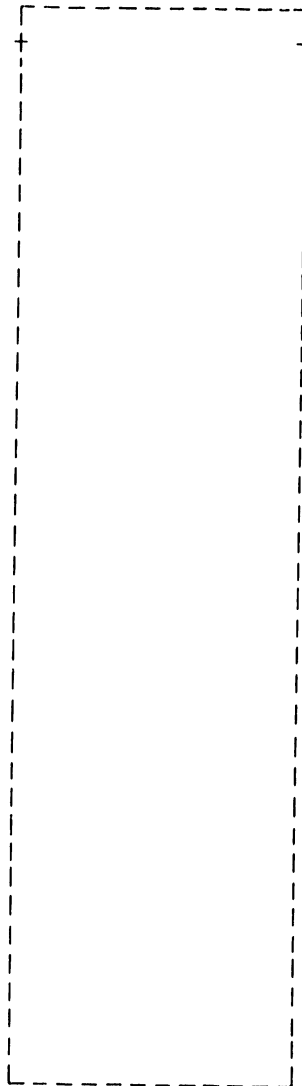

J29 ->> 17

J29 ->> 16

0703 J31-10
0801 J30-10
0703 J31-11
0801 J30-11

LOGIC CROSS REFERENCE INFORMATION

PUB	83324630	REV	D
CROSS REF NO	0414	PAGE	1-106.26

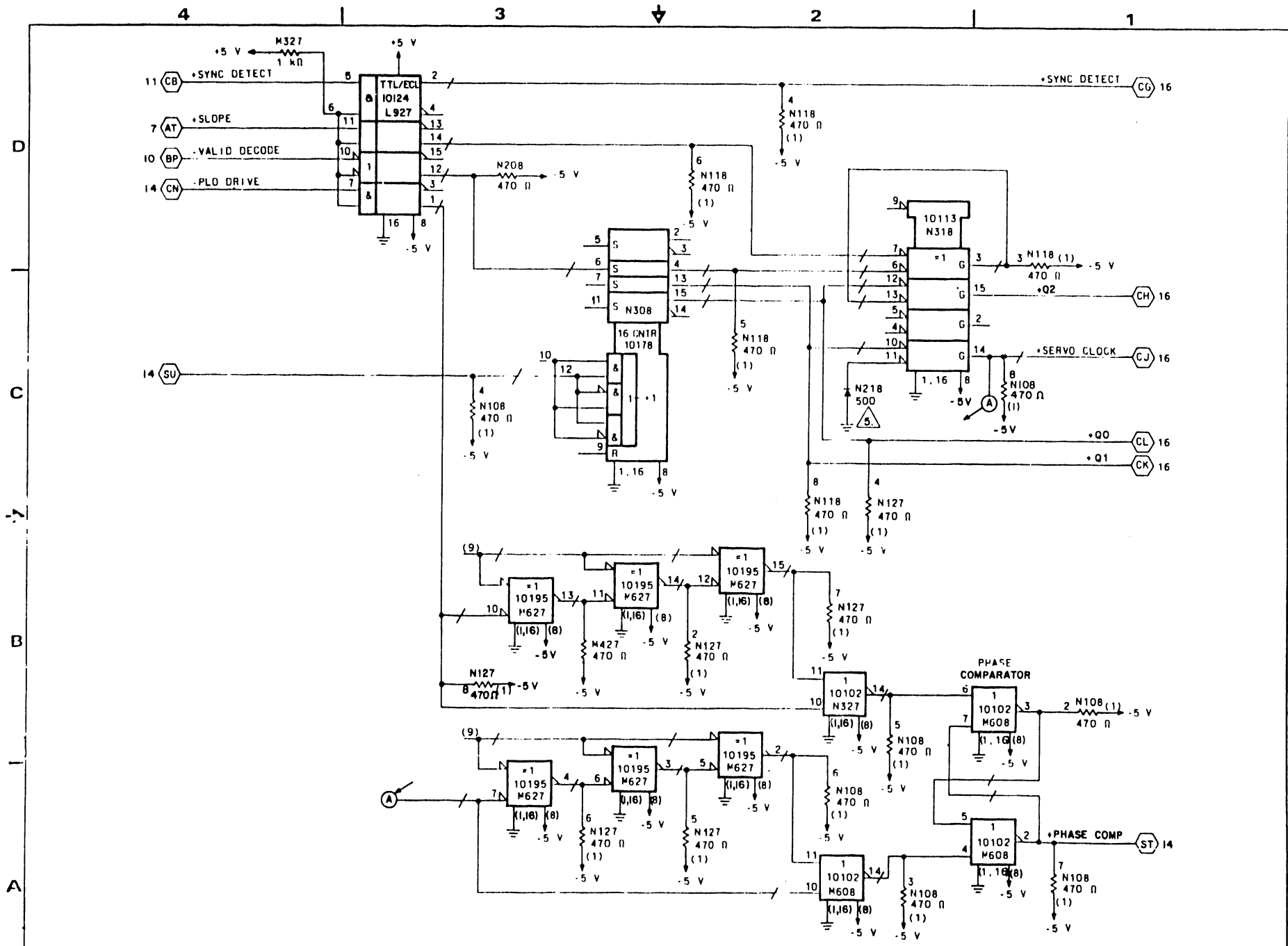

MAGNETIC PERIPHERALS INC SERVO TRIBIT DECODER PART 5 TYPE: -PEX	TWIN CITIES DISK DIVISION	C	83324630	D
	CIRCUIT 19333	0415	3M1115	1-106.29

P 54332202↑

D
C
B
A

A

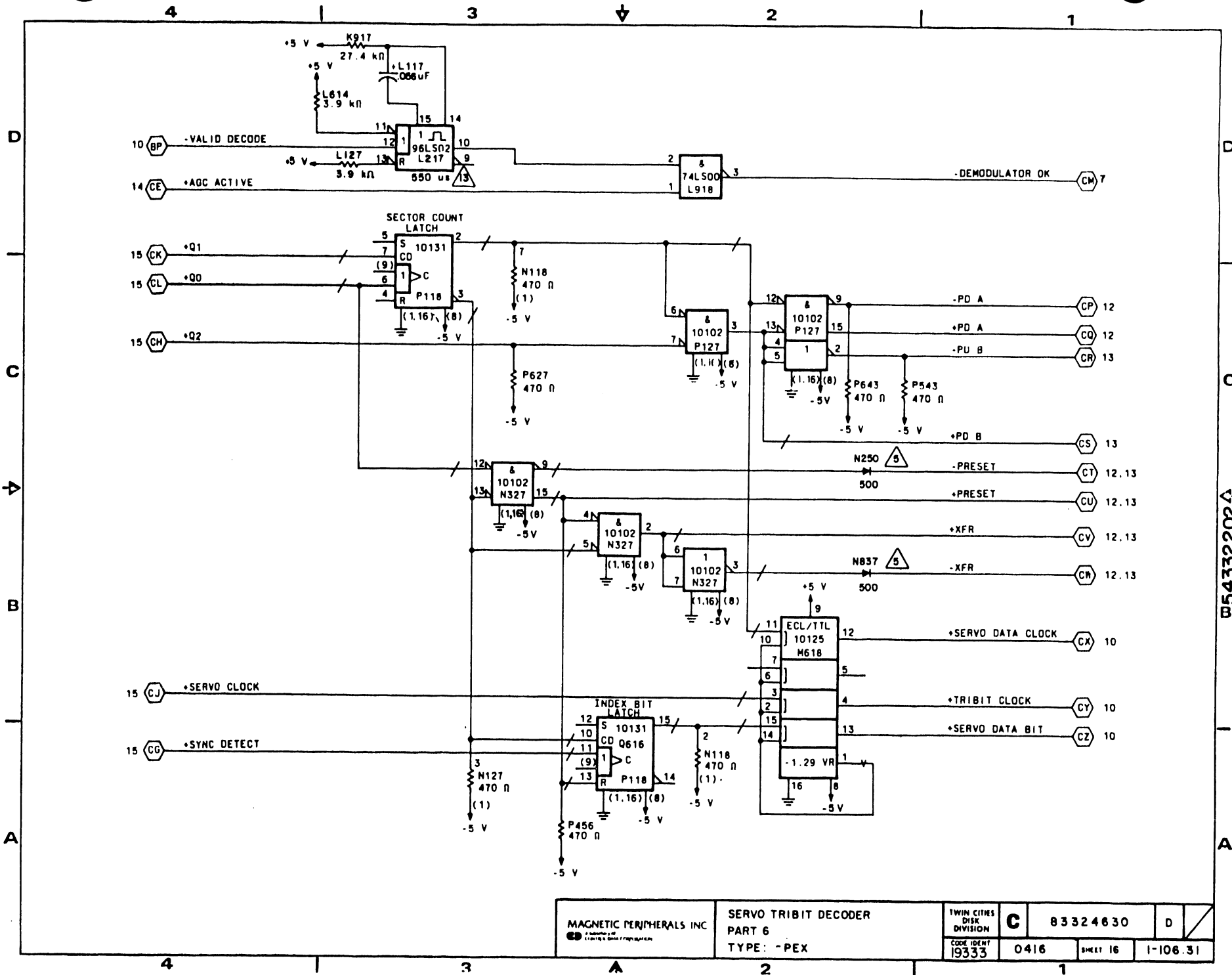

MAGNETIC PERIPHERALS INC <small>A Division of General Electric Company</small>	SERVO TRIBIT DECODER PART 6 TYPE: -PEX			TWIN CITIES DISK DIVISION	C	83324630	D
	CODE IDENT 19333		0416	SHEET 16	I-106.31		

P543322024

SIGNAL INPUTS

SIGNAL OUTPUTS

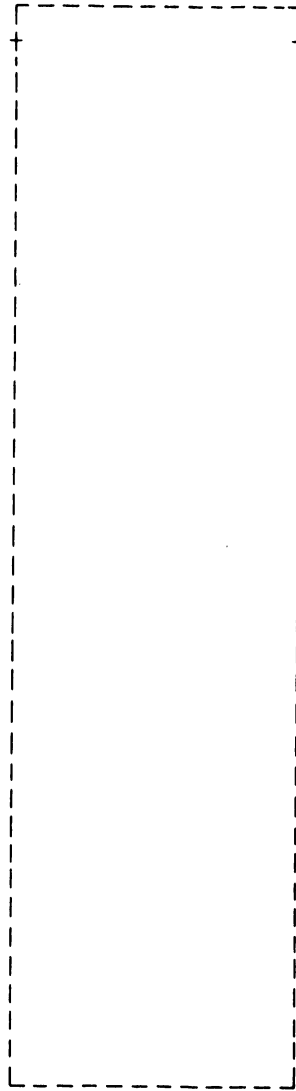

J13 >> 05

Servo Test Jack

LOGIC CROSS REFERENCE INFORMATION

PUB	83324630	REV	D
CROSS REF NO	0417	PAGE	1-106.32

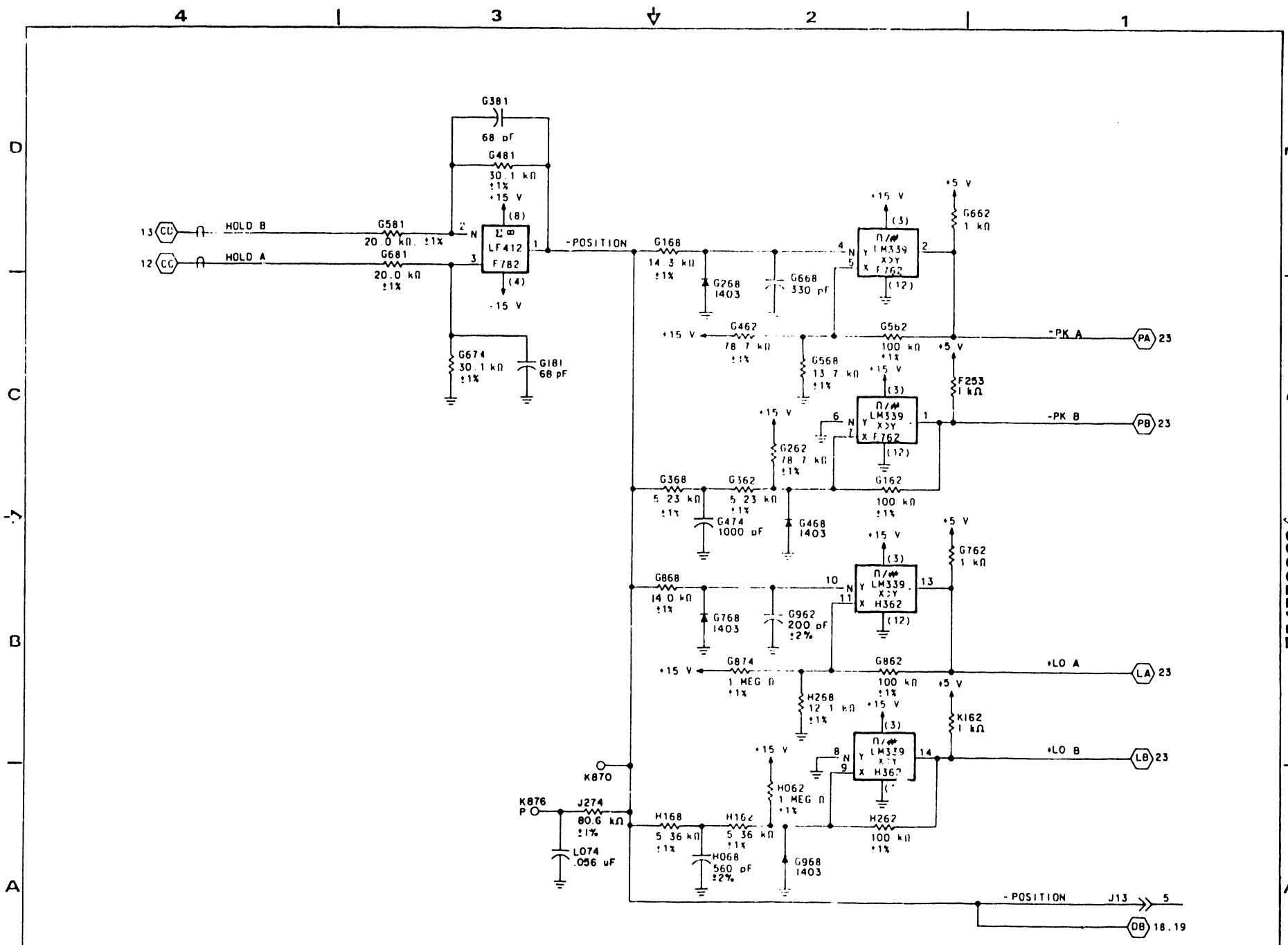

0543322024

MAGNETIC PERIPHERALS INC. 	POSITION	TWIN CITIES DISK DIVISION	C	83324630	D
	TYPE - PEX	DATE DESIGNED	19333	0417	SHEET 17

SIGNAL INPUTS

SINGLE		DUAL			
<u>CHANNEL</u>	<u>UNITS</u>	<u>CHANNEL</u>	<u>UNITS</u>		
0206	J20-38	0212	J20-03	39	>> J14
0206	J20-40	0212	J20-01	40	>> J14

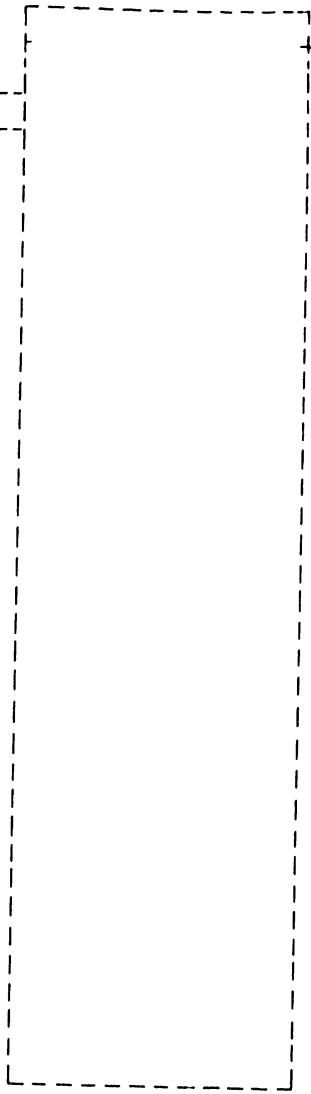

SIGNAL OUTPUTS

J13	>> 03	Servo Test Jack
J13	>> 04	Servo Test Jack
J13	>> 01	Servo Test Jack

LOGIC CROSS REFERENCE INFORMATION

PUB 83324630		REV D
CROSS REF NO 0418	PAGE 1-106.34	

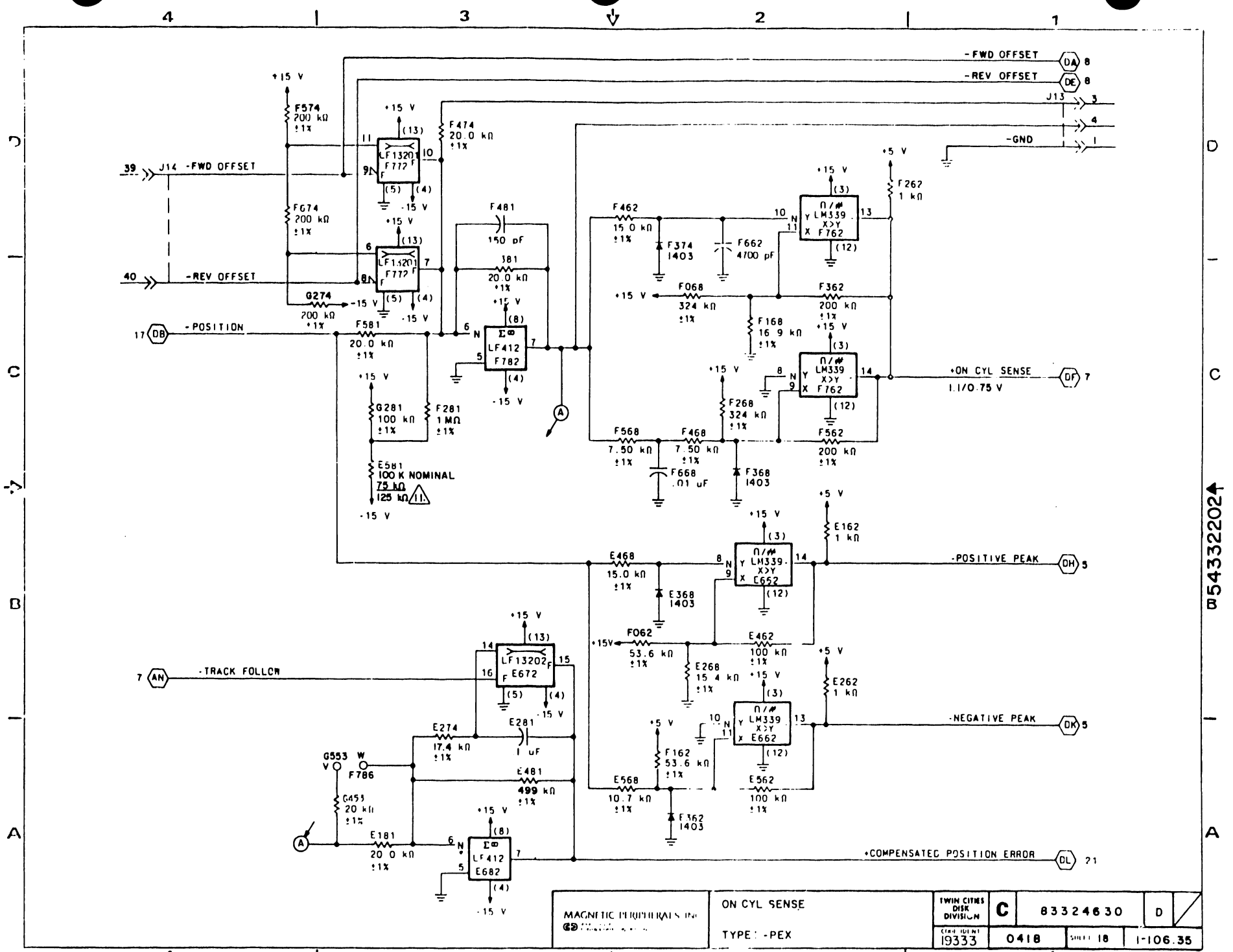

B54332202A

MAGNETIC PERIPHERALS DIVISION	ON CYL SENSE		TWIN CITIES DISK DIVISION	C	83324630	D
	TYPE: -PEX		CHG IDENT	19333	0418	SHEET 18

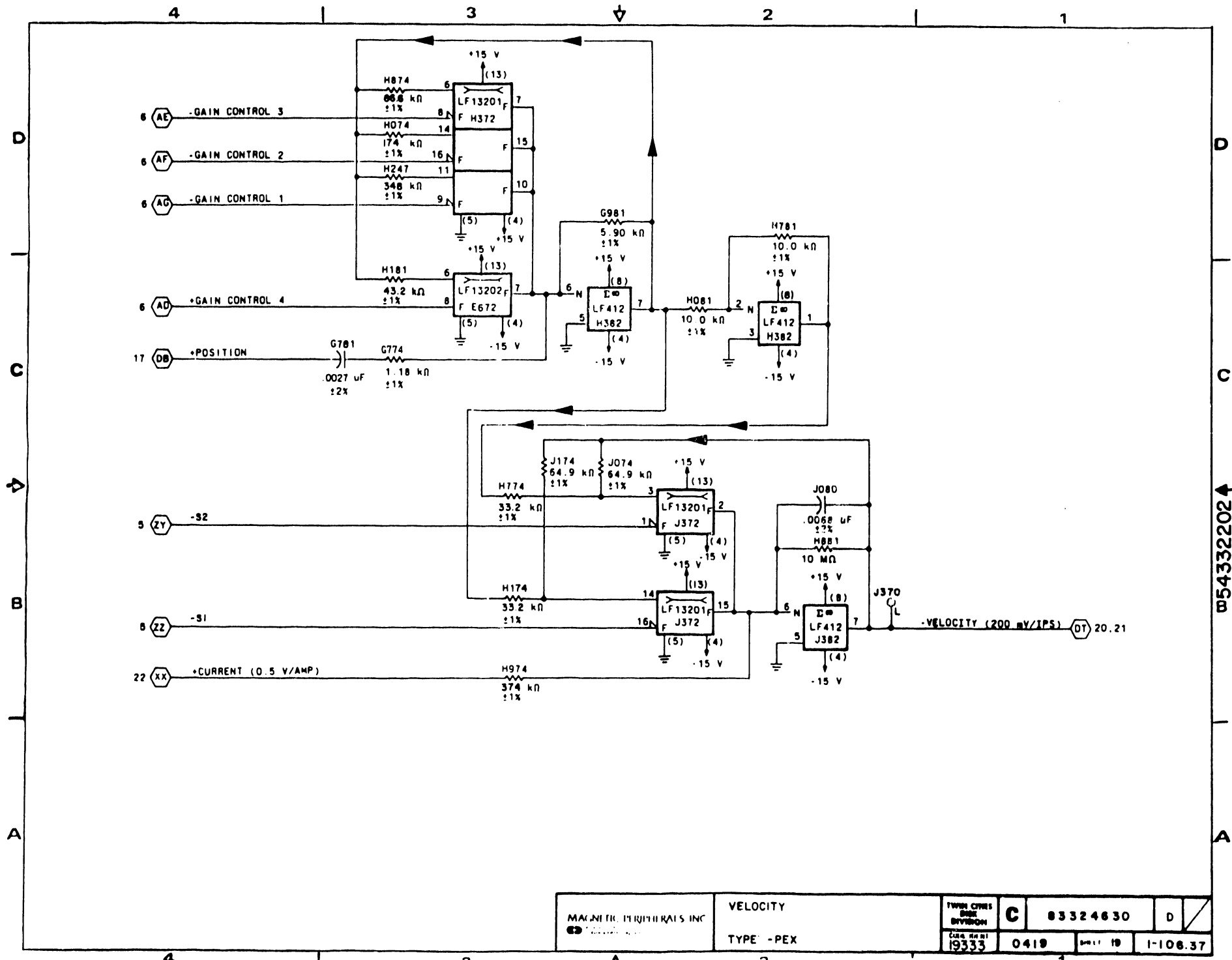

MAGNETIC INSTRUMENTS INC. 	VELOCITY	TWIN CIRCLE DISK DIVISION	C	83324630	D
	TYPE -PEX	19333	0419	REV. 11-19	1-106.37

54332202A

SIGNAL INPUTS

SIGNAL OUTPUTS

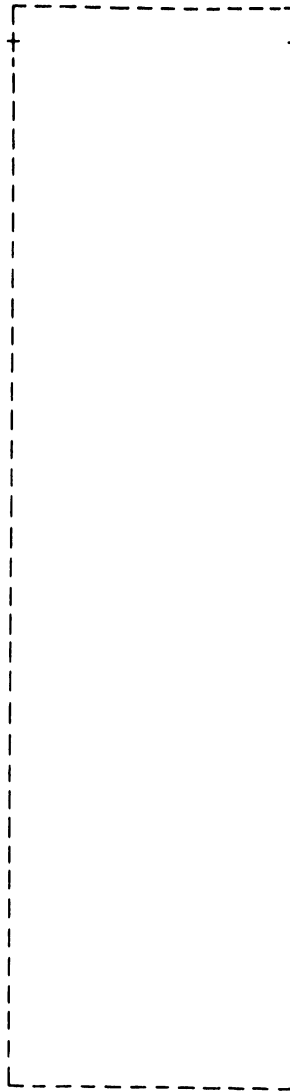

J29 ->> 21

0701 J31-06
0803 J30-06

LOGIC CROSS REFERENCE INFORMATION

PUB		83324630	REV	D
CROSS REF NO	0420	PAGE	1-106.38	

SIGNAL INPUTS

0502 P23-09 09 >> J23

SIGNAL OUTPUTS

J23 >> 11 0502 P23-11

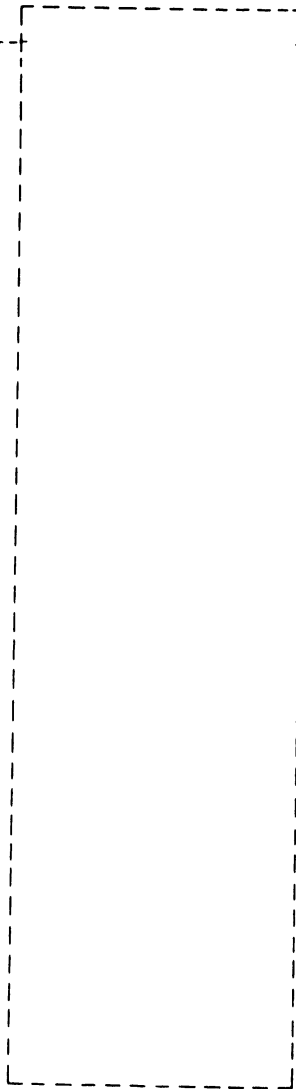

LOGIC CROSS REFERENCE INFORMATION

PUB	83324630	REV	D
CROSS REF NO	0421	PAGE	1-106.40

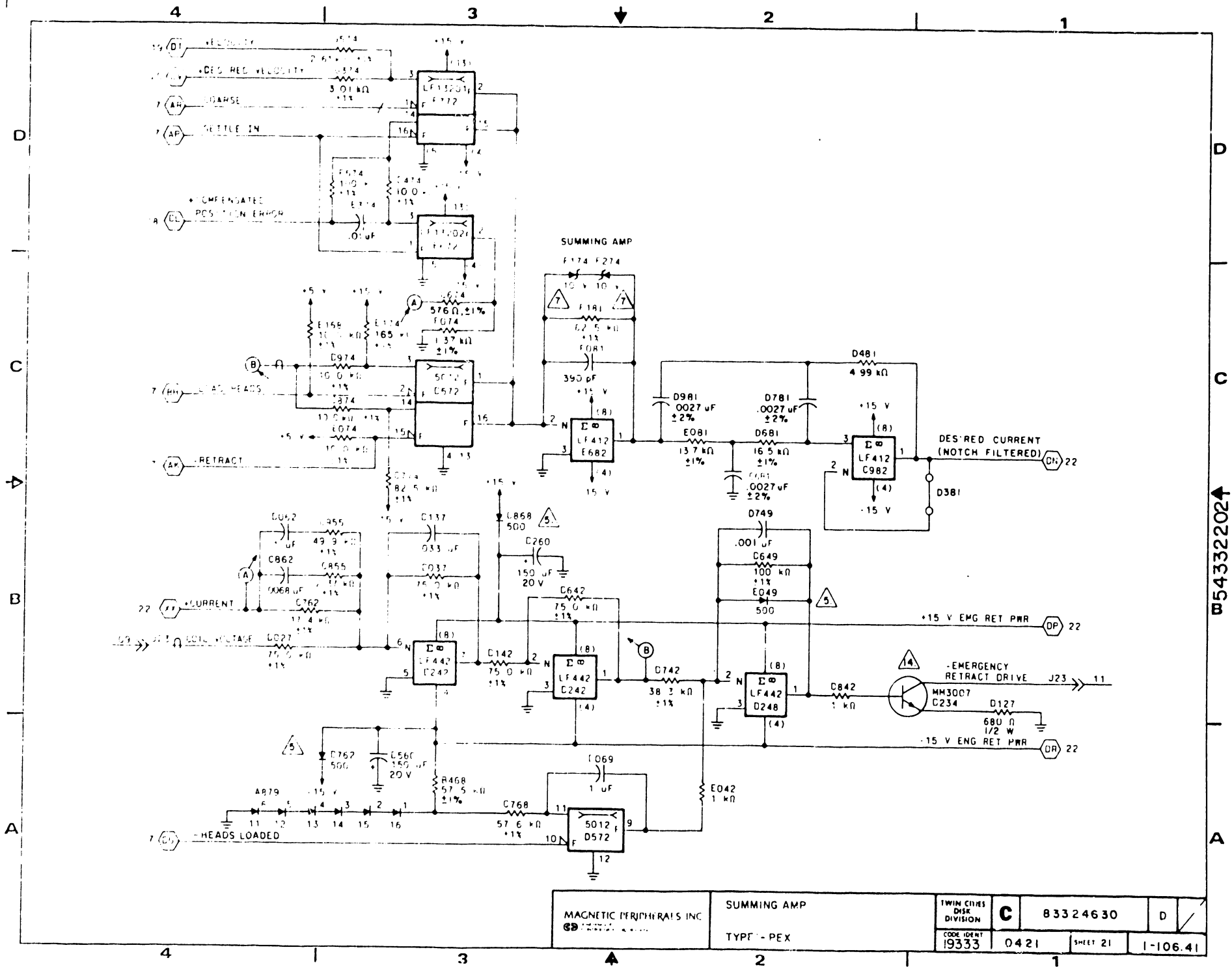

54332202A

MAGNETIC PERIPHERALS INC. 9900 E. 10th Ave., Denver, CO 80231	SUMMING AMP		TWIN CITIES DISK DIVISION	C	83324630	D
	TYPE - PEX		CODE IDENT 19333	0421	SHEET 21	1-106.41

SIGNAL INPUTS

0502 P23-07 07 >> J23
0502 P23-05 05 >> J23

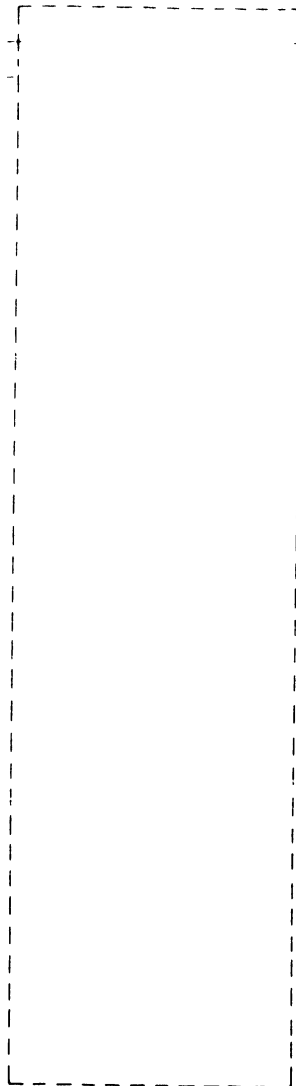

SIGNAL OUTPUTS

J13 >> 02 Servo Test Jack
J23 >> 03 0502 P23 03
J23 >> 01 0502 P23-01

LOGIC CROSS REFERENCE INFORMATION

PUB	83324630	REV	D
CROSS REF NO	0422	PAGE	1-106.42

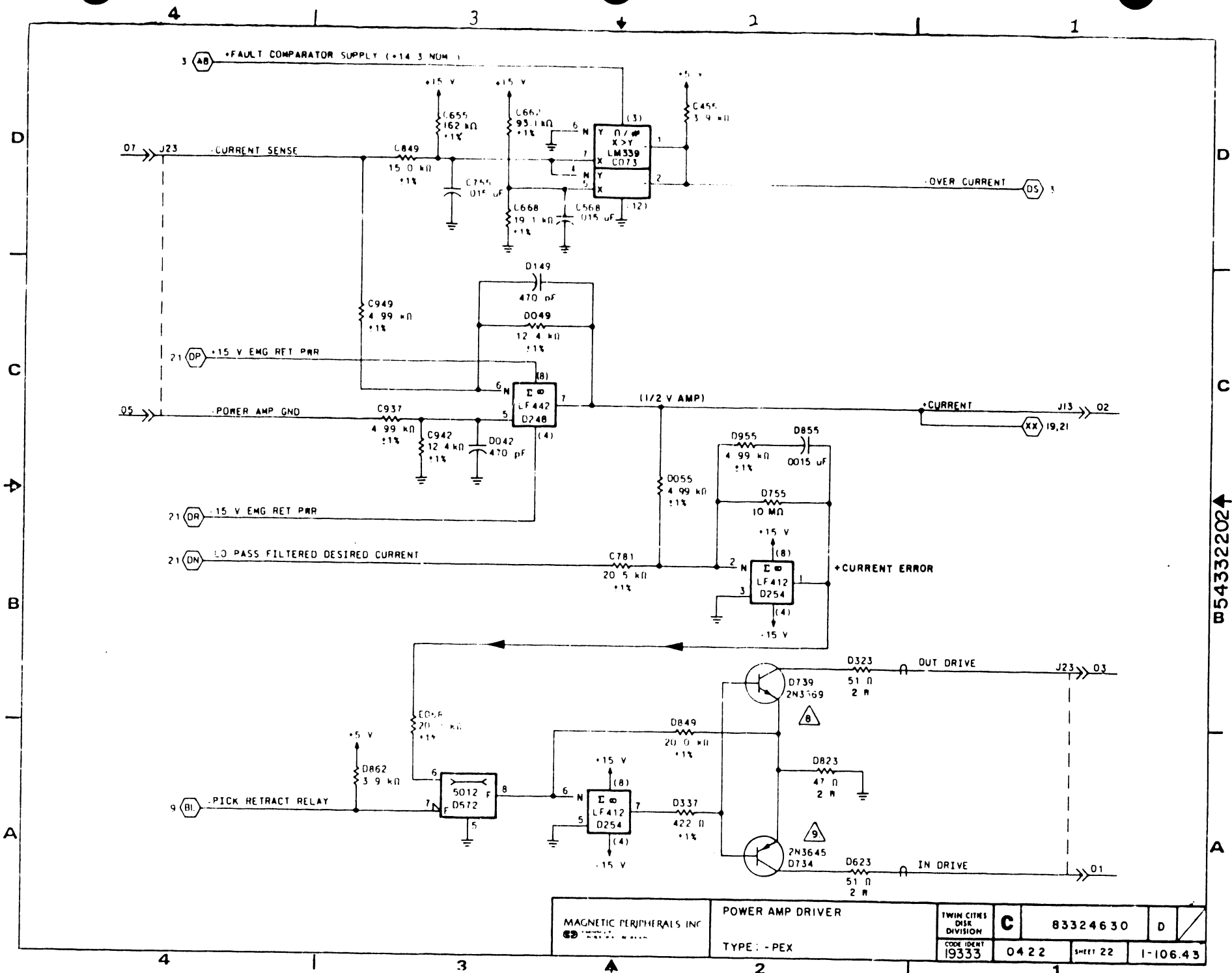

MAGNETIC PERIPHERALS INC 9333	POWER AMP DRIVER		TWIN CITIES DISK DIVISION	C	83324630	D
	TYPE: -PEX		CODE IDENT 19333			

W543322024

SIGNAL INPUTS

1002	J40-07	06	J22
1002	J40-13	01	J22
0601	J37-01	04	J22
1002	J40-14	03	J22
1002	J40-15	02	J22
NC	-	05	J22

SIGNAL OUTPUTS

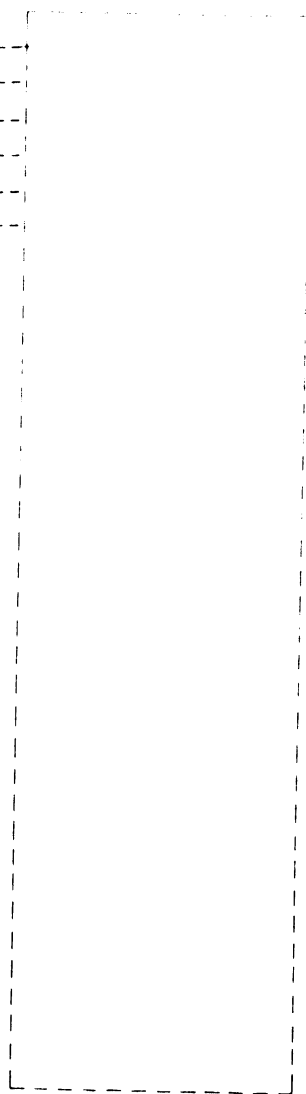

LOGIC CROSS REFERENCE INFORMATION

PUB	83324630	REV	D
CROSS REF NO	0501	PAGE	1-106.46

PART NO RANGE	REVISION RECORD						
	REV	ECO	DESCRIPTION	DRY	DATE	CHKD	APP
00 THRU 99	01	003027A	PRE-RELEASED		4/28/72	AS	II
	02	003073	CHG CONN	DRY	7/23/72	DD	II
	A	003073	RELEASED	DRY	8/18/72	DD	II

NOTES

- 1 UNLESS OTHERWISE SPECIFIED
- ALL DIODES: 95637301
- ALL RECTIFIERS: A15A, 95588200
- ALL TRANSISTORS SPNP: 2N3792, 50221401
- ALL DARLINGTON TRANSISTORS SPNP: 17K100, 52223603
- 2 TRANSISTOR, SPNP, 2N3716, 50221301

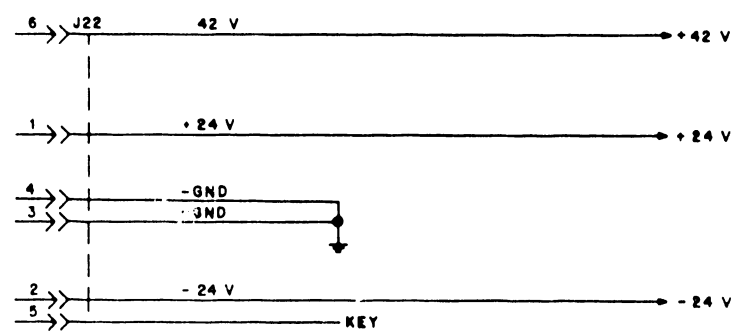

REFERENCE DRAWING			MAGNETIC PERIPHERALS INC		TITLE	
COMP ASSY 54331701			FIRST USED ON		NEXT ASSEMBLY	
TEST REQ. 54331901			PASAI-A		SCHEMATIC DIAGRAM	
COMPONENTS EXCEPT AS NOTED			DWN		D. G. D.	
TOLERANCE			VAL		RATING	
RES			CHKD		D. G. D.	
CAP			ENGR		4-20-72	
			MFG		4-21-72	
			QA		M. B. S.	
			DATE		8/26/72	
			PART NO		19333	
			SIZE		C	
			SMALL DISK DIVISION		83324630	
			SHEET		1 OF 3	
			PAGE		1-107	
			REF: 54331801		PRODUCT RSD	

SIGNAL INPUTS

0421	J23-11	-11->>	P23	-----
0402	J23-12	-12->>	P23	-----
0422	J23-03	-03->>	P23	-----
0402	J23-04	-04->>	P23	-----
0422	J23-01	-01->>	P23	-----
0402	J23-02	-02->>	P23	-----
0409	J23-13	-13->>	P23	-----
0402	J23-14	-14->>	P23	-----

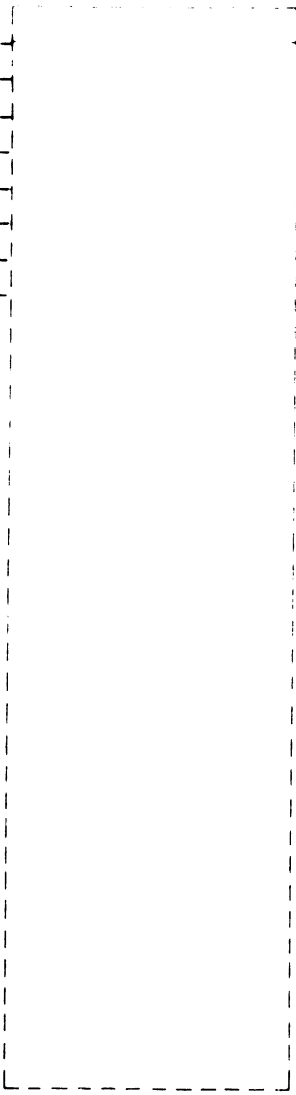

SIGNAL OUTPUTS

P23	>>>	09	0421	J23-09
P23	>>>	10	0402	J23-10
J43	>>>	01		To Voice Coil
J43	>>>	02		To Voice Coil
J43	>>>	03		To Voice Coil
J43	>>>	04		To Voice Coil
P23	>>>	07	0422	J23-07
P23	>>>	08	0402	J23-08
P23	>>>	05	0422	J23-05
P23	>>>	06	0402	J23-06

LOGIC CROSS REFERENCE INFORMATION

PUB		83324630		REV	B
CROSS REF NO	0502	PAGE	1-108		

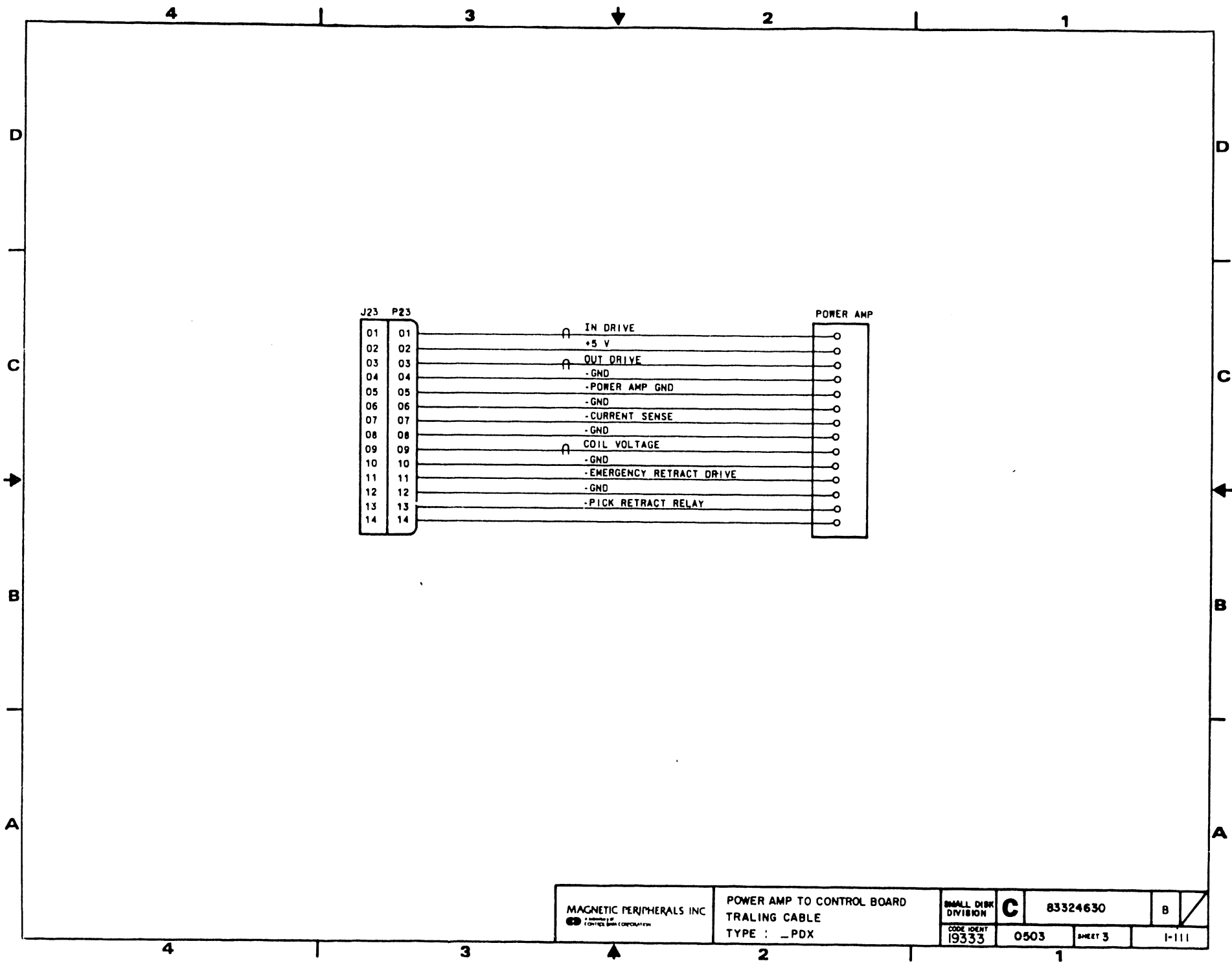

SIGNAL INPUTS

0402	J24-02	02	>>	P24	-----
0402	J24-04	04	>>	P24	-----
0402	J24-08	08	>>	P24	-----
0402	J24-10	10	>>	P24	-----
0402	J24-12	12	>>	P24	-----
0402	J24-14	14	>>	P24	-----
1002	J40-07	06	>>	J37	-----
1002	J40-08	05	>>	J37	-----
1002	J40-13	04	>>	J37	-----

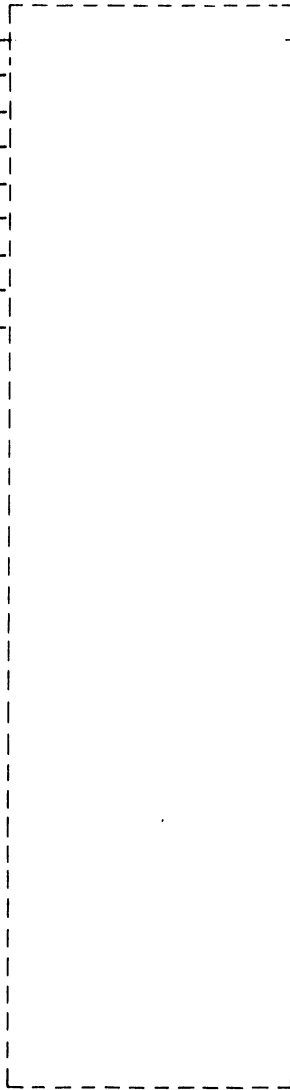

SIGNAL OUTPUTS

-----	J39	>>	07	To Motor
-----	J39	>>	03	To Motor
-----	J39	>>	06	To Motor
-----	J37	>>	01	0501 J22-04

LOGIC CROSS REFERENCE INFORMATION

PUB		83324630	REV	B
CROSS REF NO	0601	PAGE		1-112

UNUSED LOGIC ELEMENTS 2

ELEMENT	LOCATION	OUTPUT PIN (S)
7404	E803	12

FILTER CAPS 3

VOLTAGE	CAPACITANCE
+5 V	.1 uF
E120	
D640	
D804	
D104	
E104	
E127	
C611	

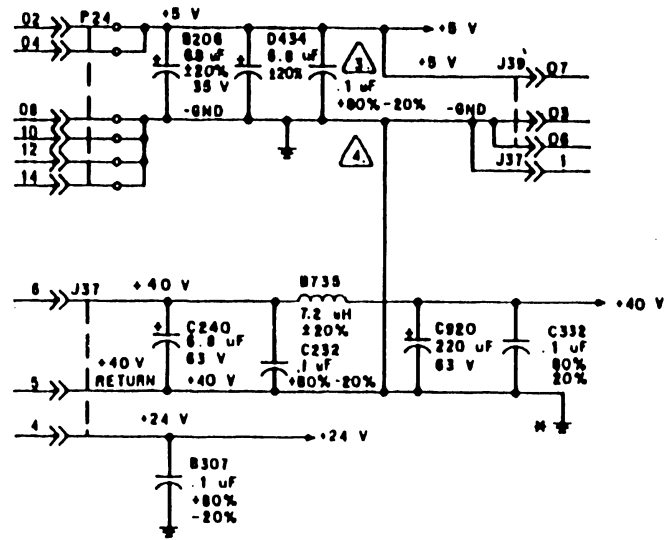

PART NO RANGE	REVISION RECORD						
	REV	ECO	DESCRIPTION	DATE	CHKD	APP	
00 THRU 99	01	0103M3B	PRE-RELEASED	4/6/82	82	DB	
	02	0103022	CHG LSI PROGRAM	DM	7/7/82	GD	II
	A	0103005	RELEASED	DM	9/7/82	GS	II
	B	0103011	ADD PIN TO SMT REF	OLM	10/13/82	OCB	II
	C	0103009	CORRECTIONS	MJ	7/14/83		

NOTES:

- UNLESS OTHERWISE SPECIFIED:
ALL 16 PIN IC'S HAVE PIN 8 CONNECTED TO GND AND PIN 16 CONNECTED TO +5 V.
ALL 14 PIN IC'S HAVE PIN 7 CONNECTED TO GND AND PIN 14 CONNECTED TO +5 V.
ALL DIODES 95500200.
ALL RESISTOR PACK RESISTORS ±3% 1/8 W.
- UNUSED LOGIC ELEMENT INPUT PINS ARE GROUNDED.
- SEE TABLE FOR FILTER CAP LOCATIONS.
- +40 V RETURN AND GND TIED TOGETHER AT ONLY ONE POINT. +40 V RETURN IS INDICATED BY \overline{M} .
- GND ON FSD ONLY.

REFERENCE DRAWING		MAGNETIC PERIPHERALS INC		TITLE			
COMP ASSY 84334002		PABAI-A		SCHEMATIC DIAGRAM			
CTR 84338102		PABAI-A		MOTOR SPEED CONTROL			
				TYPE CPMX			
COMPONENTS, EXCEPT AS NOTED		DWYN	P.A.	12/22/81	SIZE		
TOLERANCE	VALUE	RATING	CHKD	5/27/82	SMALL DIM DIVISION		
RES	1%	OHMS	1/4 W	6-1-82	C	83324630	C
CAP	10%						
		MFG	1-1-82	1-1-82			
		CA	21 Hank	9-16-82	19333	0801	SHEET 1 OF 5
				REF: 84335002	PAGE 1-113		

SIGNAL INPUTS

0404 J24-05 05 -> P24
 0407 J24-11 11 -> P24
 0409 J24-06 06 -> P24
 1032 P39-04 04 -> J39
 1032 P39-01 01 -> J39
 1032 P39-05 05 -> J39

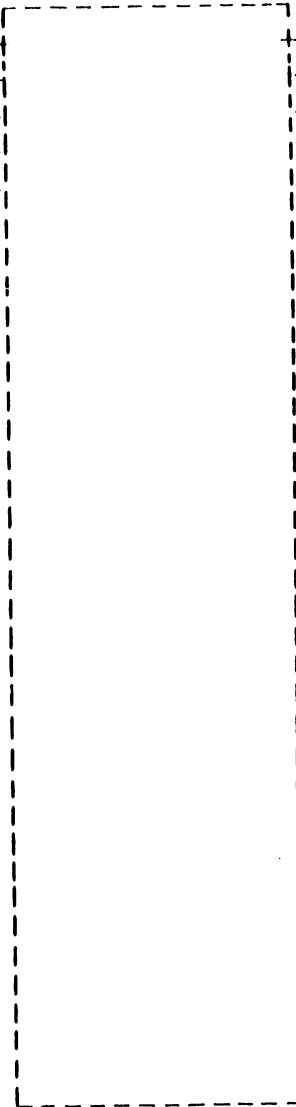

SIGNAL OUTPUTS

J37 -> 03 1002 J40-12
 P24 -> 01 0409 J24-01
 P24 -> 09 0408 J24-09
 J41 -> 01 NC -
 J41 -> 02 NC -
 P24 -> 07 0408 J24-07

LOGIC CROSS REFERENCE INFORMATION

PUB 83324630		REV B
CROSS REF NO 0602	PAGE 1-114	

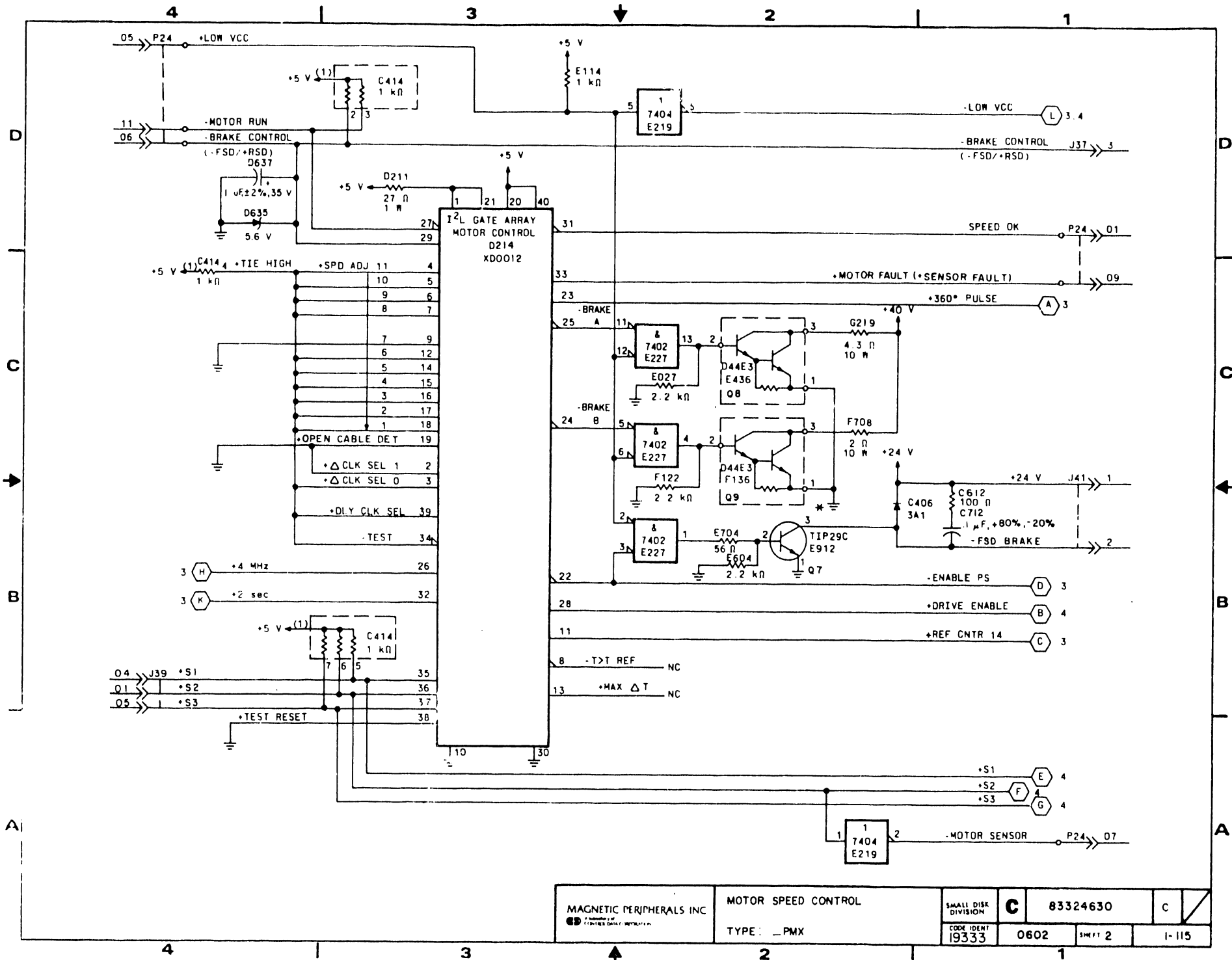

SIGNAL INPUTS

0410 J24-13 13 >> P24

SIGNAL OUTPUTS

J37 >> 02 1002 J40-09
P24 >> 03 0409 J24-03

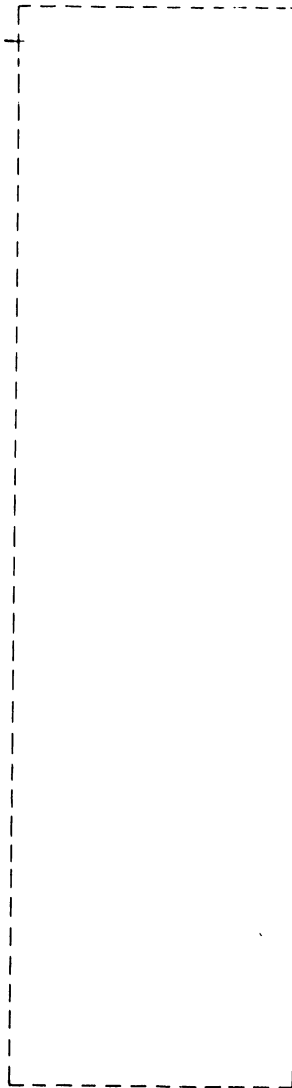

LOGIC CROSS REFERENCE INFORMATION

PUB	83324630	REV	B
CROSS REF NO	0603	PAGE	1-116

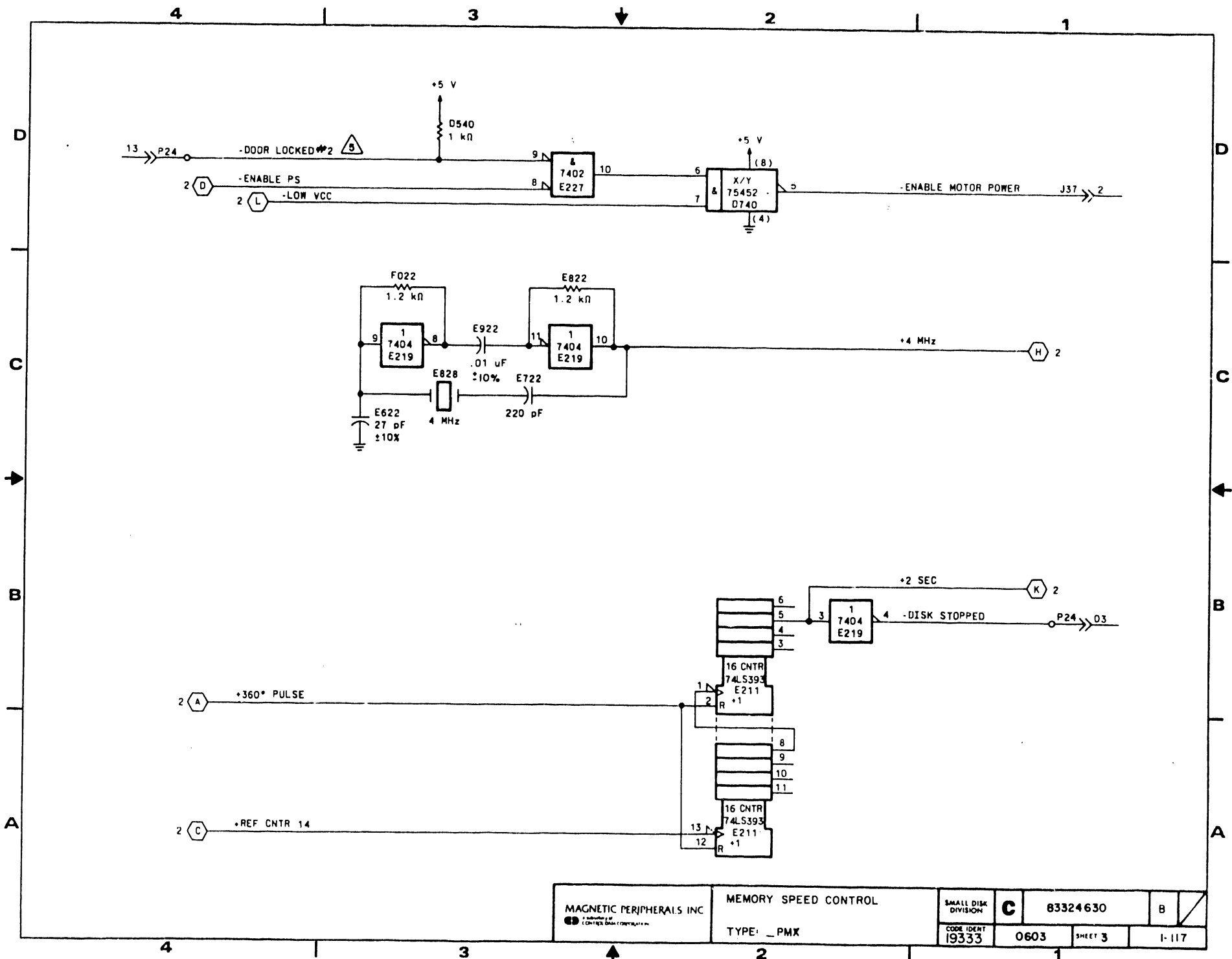

SIGNAL INPUTS

SIGNAL OUTPUTS

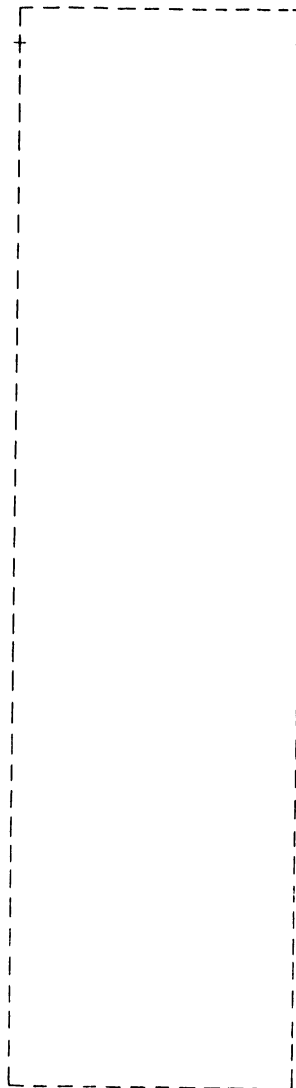

J39 >> 02 1032 P39-02
J39 >> 08 1032 P39-08
J39 >> 09 1032 P39-09

LOGIC CROSS REFERENCE INFORMATION

PUB	83324630	REV	B
CROSS REF NO	0604	PAGE	1-118

4 | 3 | 2 | 1

D
C
B
A

D
C
B
A

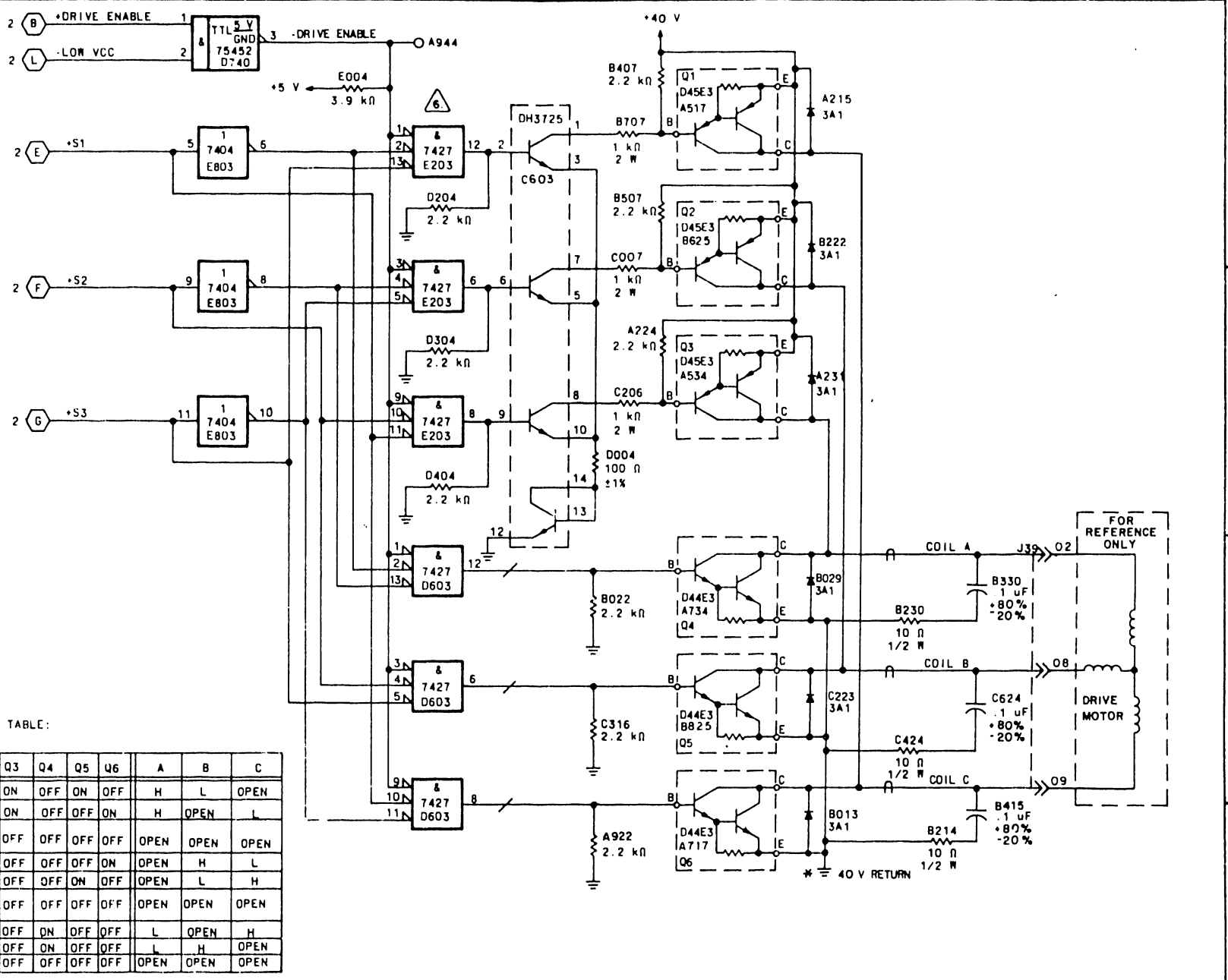

6. DECODER TRUTH TABLE:

EN	S1	S2	S3	Q1	Q2	Q3	Q4	Q5	Q6	A	B	C
L	L	L	L	OFF	OFF	ON	OFF	ON	OFF	H	L	OPEN
L	L	L	H	OFF	OFF	ON	OFF	OFF	ON	H	OPEN	L
X	L	H	L	△	OFF	OFF	OFF	OFF	OFF	OPEN	OPEN	OPEN
L	L	H	H	OFF	ON	OFF	OFF	OFF	ON	OPEN	H	L
L	H	L	L	ON	OFF	OFF	OFF	ON	OFF	OPEN	L	H
X	H	L	H	△	OFF	OFF	OFF	OFF	OFF	OPEN	OPEN	OPEN
L	H	H	L	ON	OFF	OFF	ON	OFF	OFF	L	OPEN	H
L	H	H	H	OFF	ON	OFF	ON	OFF	OFF	L	H	OPEN
H	X	X	X	OFF	OFF	OFF	OFF	OFF	OFF	OPEN	OPEN	OPEN

7. THESE ARE FAULT CONDITIONS DECODED IN THE LSI CHIP. THESE CONDITIONS DO NOT OCCUR DURING NORMAL OPERATION.

MAGNETIC PERIPHERALS INC. A Division of CENTRE DATA CORPORATION	MOTOR SPEED CONTROL		SMALL DISK DIVISION	C	83324630	B
	TYPE: ...PMX	COIL IDENT I9333	O604			

4 | 3 | 2 | 1

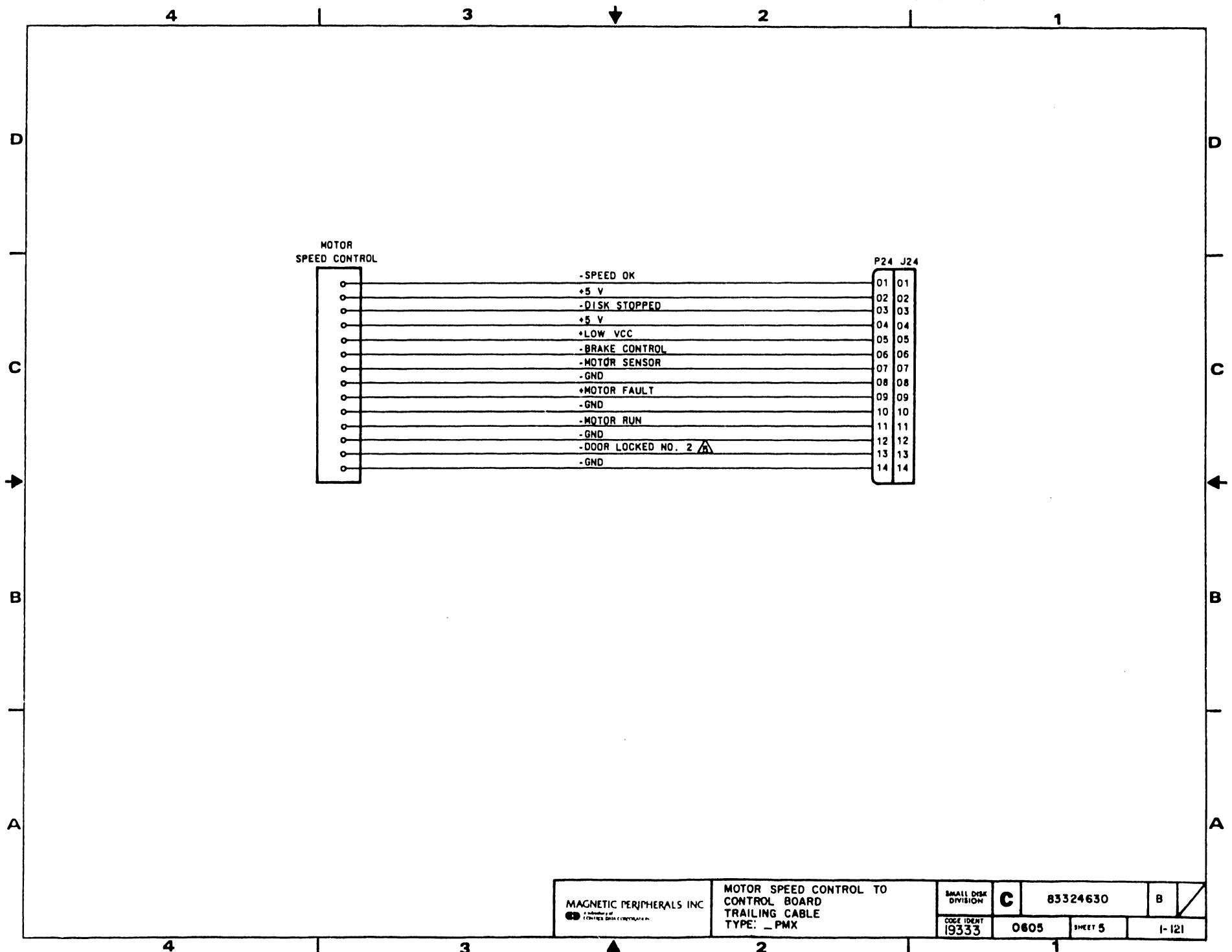

MOTOR
SPEED CONTROL

- SPEED OK
- +5 V
- DISK STOPPED
- +5 V
- +LOW VCC
- BRAKE CONTROL
- MOTOR SENSOR
- GND
- +MOTOR FAULT
- GND
- MOTOR RUN
- GND
- DOOR LOCKED NO. 2 ⚠
- GND

P24 J24	
01	01
02	02
03	03
04	04
05	05
06	06
07	07
08	08
09	09
10	10
11	11
12	12
13	13
14	14

SIGNAL INPUTS

SIGNAL OUTPUTS

SINGLE CHANNEL UNITS		DUAL CHANNEL UNITS	
----------------------	--	--------------------	--

0402	J29-03	0402	J29-03	24	>>	J31
0402	J29-04	0402	J29-04	23	>>	J31
0406	J29-26	0406	J29-26	01	>>	J31
0406	J29-24	0406	J29-24	03	>>	J31
0406	J29-22	0406	J29-22	05	>>	J31
0420	J29-21	0420	J29-21	06	>>	J31
0406	J29-20	0406	J29-20	07	>>	J31
1002	J40-01	1002	J40-01	06	>>	J36
NC	-	NC	-	05	>>	J46
1002	J40-02	1002	J40-02	05	>>	J36
0205	P27-12	0205	P27-12	12	>>	J27
0202	P27-15	0211	P27-15	15	>>	J27
0202	P27-18	0211	P27-18	18	>>	J27
NC	-	NC	-	09	>>	J31
0402	J29-15	0402	J29-15	12	>>	J31
0402	J29-12	0402	J29-12	15	>>	J31
NC	-	NC	-	19	>>	J31
NC	-	NC	-	22	>>	J31
0402	J29-01	0402	J29-01	26	>>	J31
0402	J29-02	0402	J29-02	25	>>	J31
1002	J40-03	1002	J40-03	04	>>	J36
NC	-	NC	-	01	>>	J36
NC	-	NC	-	02	>>	J36
NC	-	NC	-	03	>>	J36

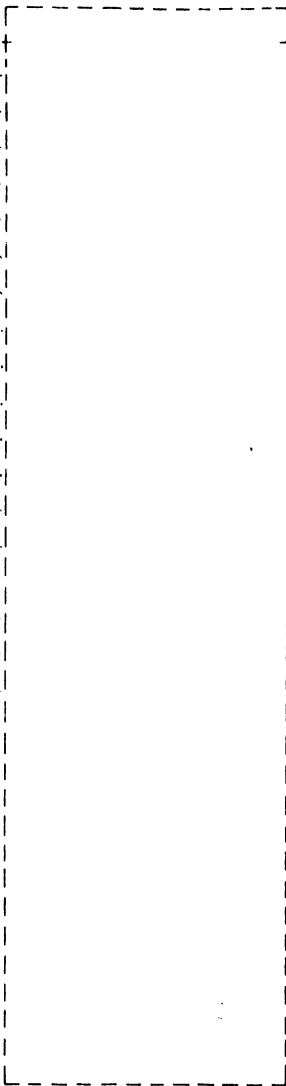

J46	>>	04	NC	-
J46	>>	06	NC	-

LOGIC CROSS REFERENCE INFORMATION

PUB	83324630	REV	B
CROSS REF NO	0701	PAGE	1-122

4

3

2

1

UNUSED LOGIC ELEMENT

TYPE	LOCATION	OUTPUT PIN(S)
74LS05	A642	6, 8, 10
10123	B905	2, 15
10124	E449	12

UNUSED RESISTOR PACKS

LOCATION	PIN(S)
B832	2, 3
B847	4, 7, 8
D205	6, 8
D246	4
E430	1, 2
B913	6

PART NO RANGE	REVISION RECORD						
	REV	ECO	DESCRIPTION	DRFL	DATE	CHKD	APP
00 THRU 99	01	DJ0284A	PRE-RELEASED		4/18/82		II
	02	DJ03012	CHK TIME DELAY	DLM	2/3/82	DGD	II
	A	DJ23000 DJ03034B	RELEASED	DLM	9/15/82	DGD	II
	B	DT01115	DELETE TP'S	DLM	1/16/82	DGD	II
	C	DJ03132	ADD PIN TO SHT REF	DLM	10/16/82	DGD	III
	D	DJ03183	BPGX TO CPGX	KKB	12/20/82		
	E	DJ03200	CPGX TO DPGX	KKB	12/20/82		
	F	DJ03366	DPGX TO FPGX	MJ	11/29/83		
	G	DJ03436	FPGX TO GPGX	CAF	2/84		

FILTER CAPS

.01 uF	
+5	-5
B918	C003
A227	C703
A357	C720
D254	E610
B203	E621
A846	E641
	D247
	D140
	C430
	B840
	B213

NOTES:

- UNLESS OTHERWISE SPECIFIED:
ALL 14 PIN IC'S HAVE PIN 7 CONNECTED TO GROUND AND PIN 14 CONNECTED TO +5V.
ALL 16 PIN IC'S HAVE PINS 1 & 16 CONNECTED TO GROUND AND PIN 8 CONNECTED TO -5V.
ALL DIODES SILICON, 24553500.
ALL TRANSISTOR ARRAY, MPQ2369, MPN, 50213300.
ALL RESISTOR PACK RESISTORS, 1/8W ±3%.
ALL DELAY LINES 94393900.
- TRANSISTOR ARRAY, MPQ4258, PNP, 15165543.
- SEE TABLE FOR .01uF FILTER CAPACITOR LOCATIONS.
- DELAY TIME FOR REFERENCE ONLY.

UNUSED PIN OF IC'S XC32201

CODE	INPUT PIN & NAME	OUTPUT PIN & NAME
-02	4 RESET	11 2ND:2 OUT
-02	7 RESET COMP	12 2ND:4 OUT
-02	6 2ND:4 IN	27 SYNC'D WRT GATE
-02		27 SYNC'D WRT GATE DELAYED
-07		22 WRT ENABLE
-07		11 SHIFT CLOCK
-07		20 SYNC CHECK
-07		19 ERROR
-07		18 -DECODED DATA
-07		17 +DECODED DATA
-08	33 RESET	29 COIN INC FREQ
-08	5 (INC + DEC FREQ) DELAYED	24 COIN FREQ
-08		12 (INC + DEC FREQ)

VOLTAGE REGULATOR H642 AND CAPACITORS G142, G144 ARE NOT ON B/C/D/F/GPGX BOARDS.

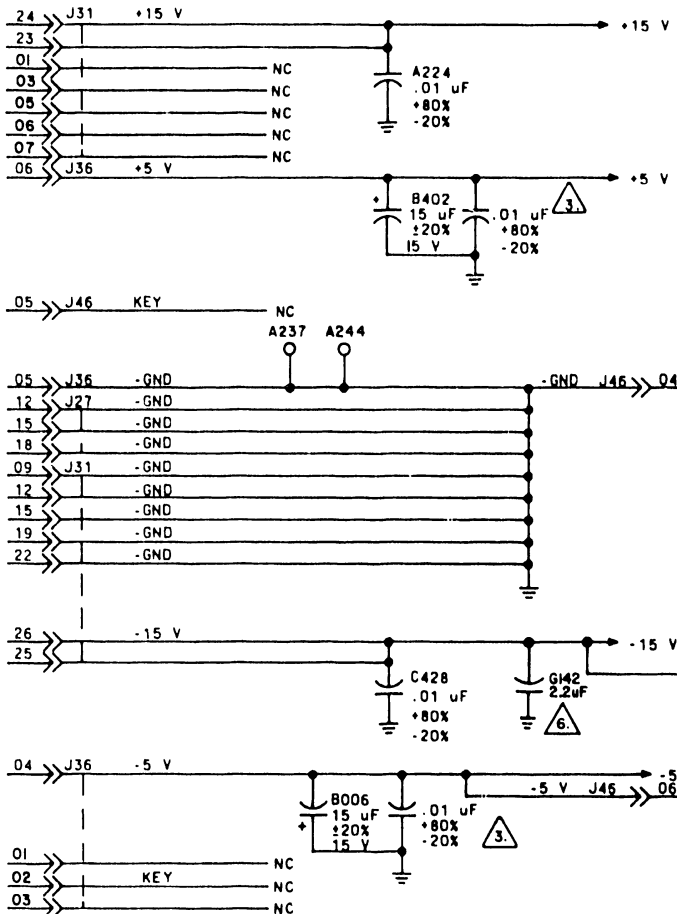

REFERENCE DRAWING			MAGNETIC PERIPHERALS INC		TITLE	
COMP ASSY 54332901			FIRST USED ON		SCHEMATIC DIAGRAM	
CTR 54333101			NEXT ASSEMBLY		READ/WRITE PLOS	
			PA3A1-A, PA5A1-A		TYPE B/C/D/F/GPGX	
COMPONENTS EXCEPT AS NOTED			DWN F. AUDETTE		DATE 4/19/82	
TOLERANCE	VALUE	RATING	CHKD	DGD	DATE	5-18-82
RES ±5%	OHMS	1/4 W	ENGR	M. J. [Signature]	DATE	5-18-82
CAP ±10%			MFG	K.M. [Signature]	DATE	2/16/82
IND ±10%			QA	M. [Signature]	DATE	1-20-82
SMALL DIM DIVISION			SIZE		C	
PART NO.			83324630		E	
SHEET 1 OF 6			PAGE 1-123			

SIGNAL INPUTS

SINGLE CHANNEL UNITS		DUAL CHANNEL UNITS			
0206	P27-07	0212	P27-07	07	J27
0202	P27-20	0211	P27-20	20	J27
0202	P27-19	0211	P27-19	19	J27
0202	P27-17	0211	P27-17	17	J27
0202	P27-16	0211	P27-16	16	J27

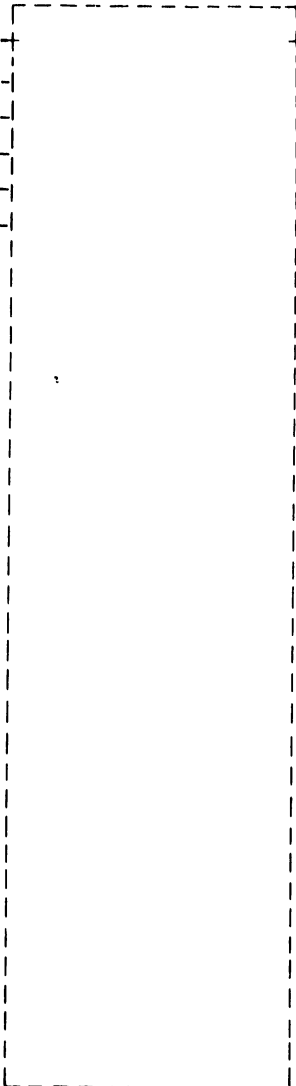

SIGNAL OUTPUTS

J27	>>	10	0205	P27-10
J27	>>	11	0205	P27-11
J27	>>	13	0205	P27-13
J27	>>	14	0205	P27-14

LOGIC CROSS REFERENCE INFORMATION

PUB		REV	
83324630		B	
CROSS REF NO	PAGE		
0702	1-124		

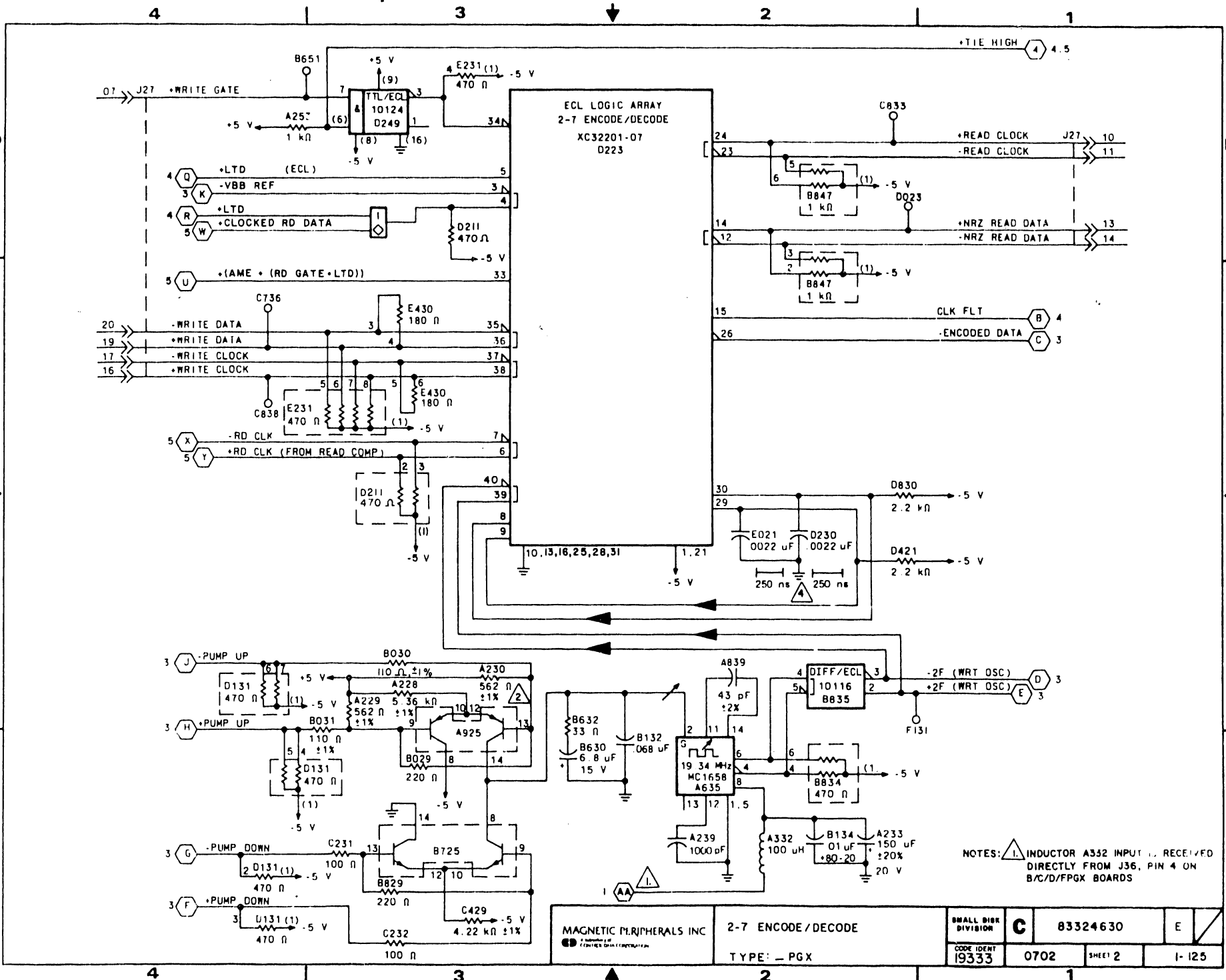

NOTES: 1. INDUCTOR A332 INPUT IS RECEIVED DIRECTLY FROM J36, PIN 4 ON B/C/D/FPGX BOARDS

MAGNETIC PERIPHERALS INC A Division of EMERSON ELECTRIC CO.	2-7 ENCODE/DECODE	SMALL DISK DIVISION	C	83324630	E
	TYPE: - PGX	CODE IDENT 19333	0702	SHEET 2	I-125

SIGNAL INPUTS

0414 J29-16 11 >> J31
 0414 J29-17 10 >> J31

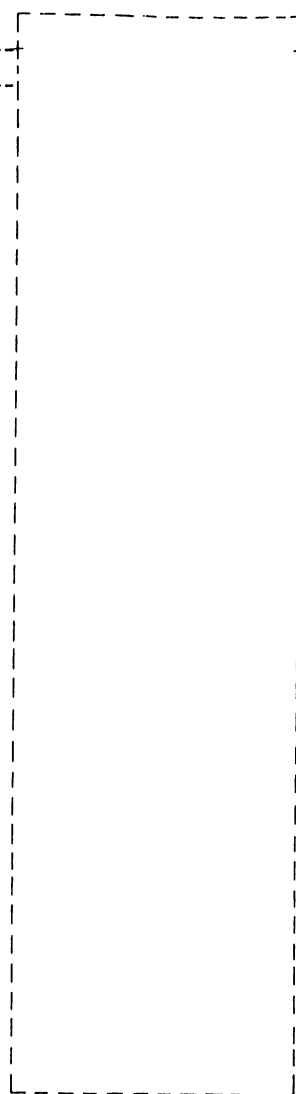

SIGNAL OUTPUTS

J31 >> 16 0802 J30-16
 J31 >> 17 0802 J30-17
 J31 >> 13 0410 J29-14
 0801 J30-13
 J31 >> 14 0410 J29-13
 0801 J30-14
 J27 >> 02 0205 P27-02
 J27 >> 01 0205 P27-01

LOGIC CROSS REFERENCE INFORMATION

PUB	83324630	REV	B
CROSS REF NO	0703	PAGE	1-126

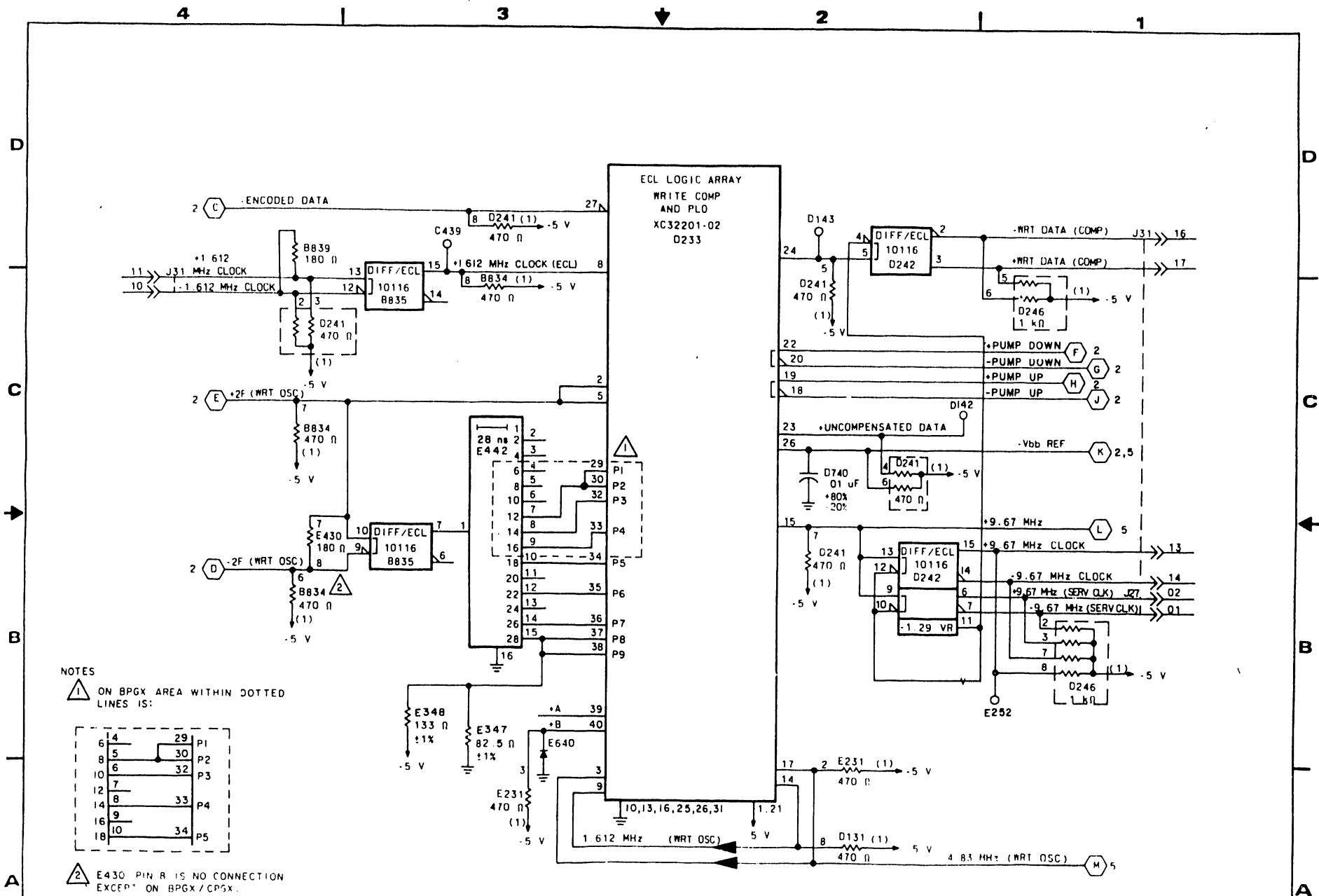

APPLIES TO B/C/DPGX CARDS ONLY.

MAGNETIC PERIPHERALS INC. <small>8000 UNIVERSITY AVENUE</small>	WRITE COMP & PLO	SMALL DISK DIVISION	C	83324630	C
	TYPE: _PGX	CODE IDENT 19333	0703	SHEET 3	1-127

SIGNAL INPUTS

0414 J29-16 11 >> J31
 0414 J29-17 10 >> J31

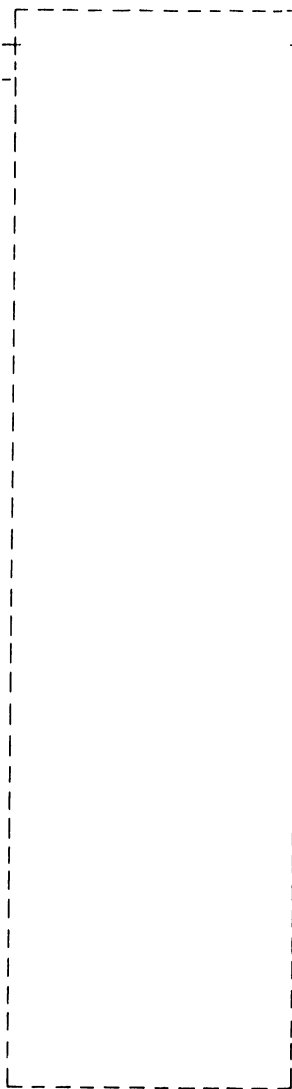

SIGNAL OUTPUTS

J31 >> 16 0802 J30-16
 J31 >> 17 0802 J30-17
 J31 >> 13 0410 J29-14
 0801 J30-13
 J31 >> 14 0410 J29-13
 0801 J30-14
 J27 >> 02 0205 P27-02
 J27 >> 01 0205 P27-01

LOGIC CROSS REFERENCE INFORMATION

PUB	83324630	REV	C
CROSS REF NO	0703	PAGE	1-128

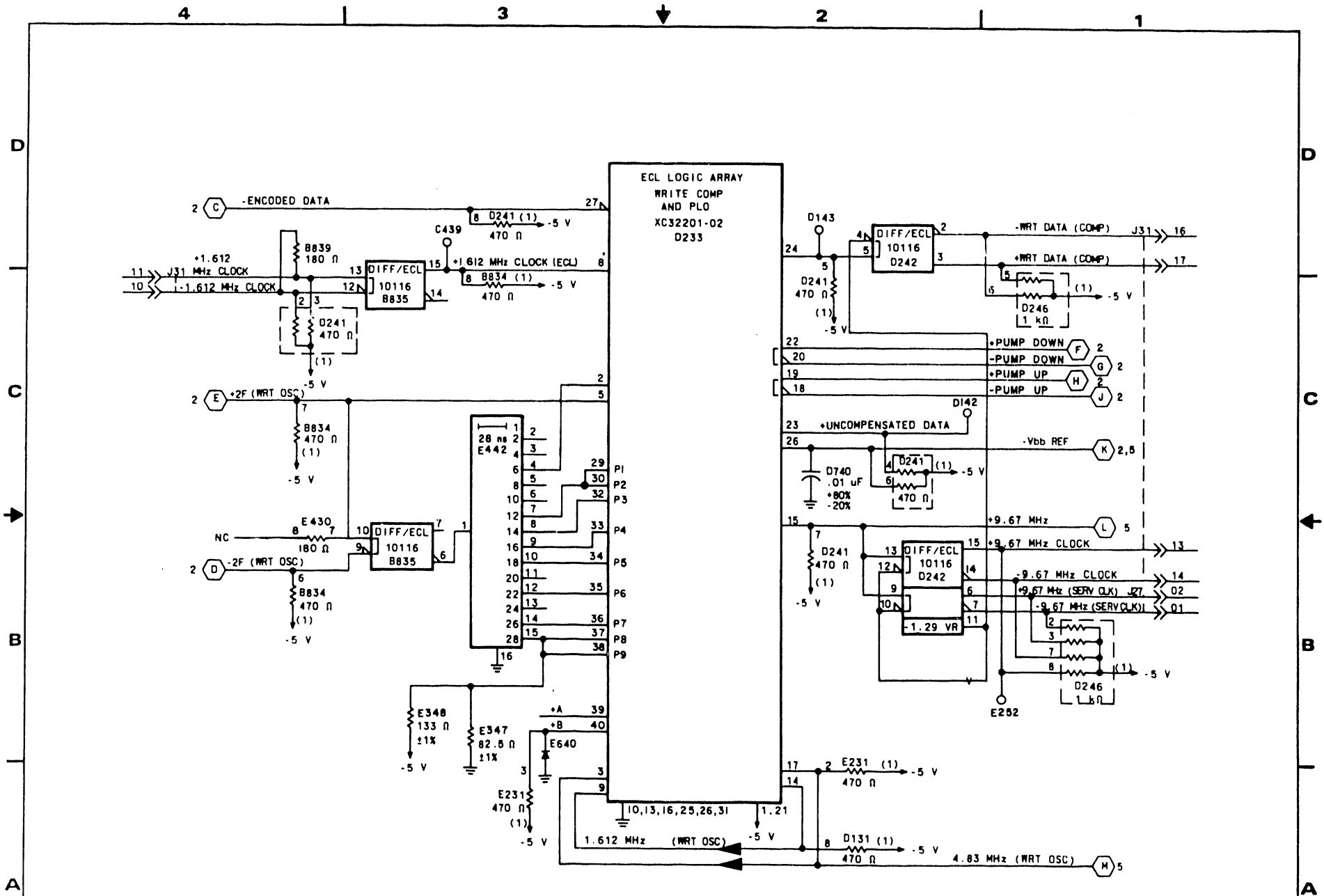

APPLIES TO ALL -PGX CARDS EXCEPT B/C/DPGX.

MAGNETIC PERIPHERALS INC. <small>A Division of</small> CONTROL DATA CORPORATION	WRITE COMP & PLO	SMALL DISK DIVISION	C	83324630	C
	TYPE: _PGX	CODE IDENT 19333	0703	SHEET 3	128.1

SIGNAL INPUTS

SINGLE			DUAL		
<u>CHANNEL UNITS</u>	<u>CHANNEL UNITS</u>		<u>CHANNEL UNITS</u>	<u>CHANNEL UNITS</u>	

0803	J30-08	0803	J30-08	08	J31
0206	P27-06	0212	P27-06	06	J27
0206	P27-09	0212	P27-09	09	J27

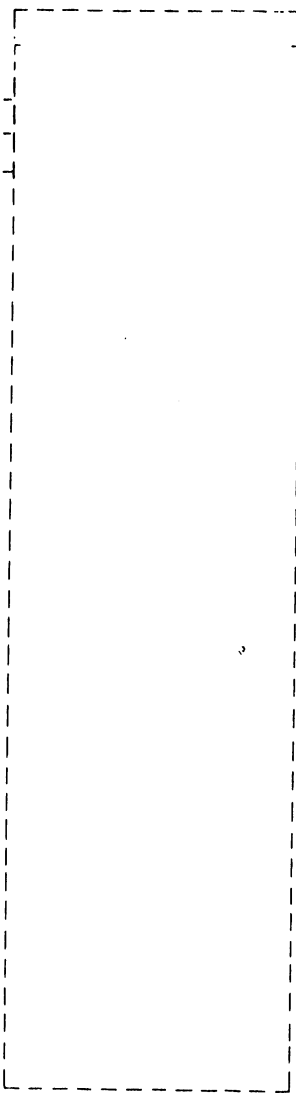

SIGNAL OUTPUTS

SINGLE			DUAL		
<u>CHANNEL UNITS</u>	<u>CHANNEL UNITS</u>		<u>CHANNEL UNITS</u>	<u>CHANNEL UNITS</u>	

J27	>>	08	0206	P27-08	0212	P27-08
J31	>>	04	0807	J30-04	0807	J30-04
J31	>>	02	NC	-	NC	-

LOGIC CROSS REFERENCE INFORMATION

PUB 83324630		REV C
CROSS REF NO 0704	PAGE 1-128.2	

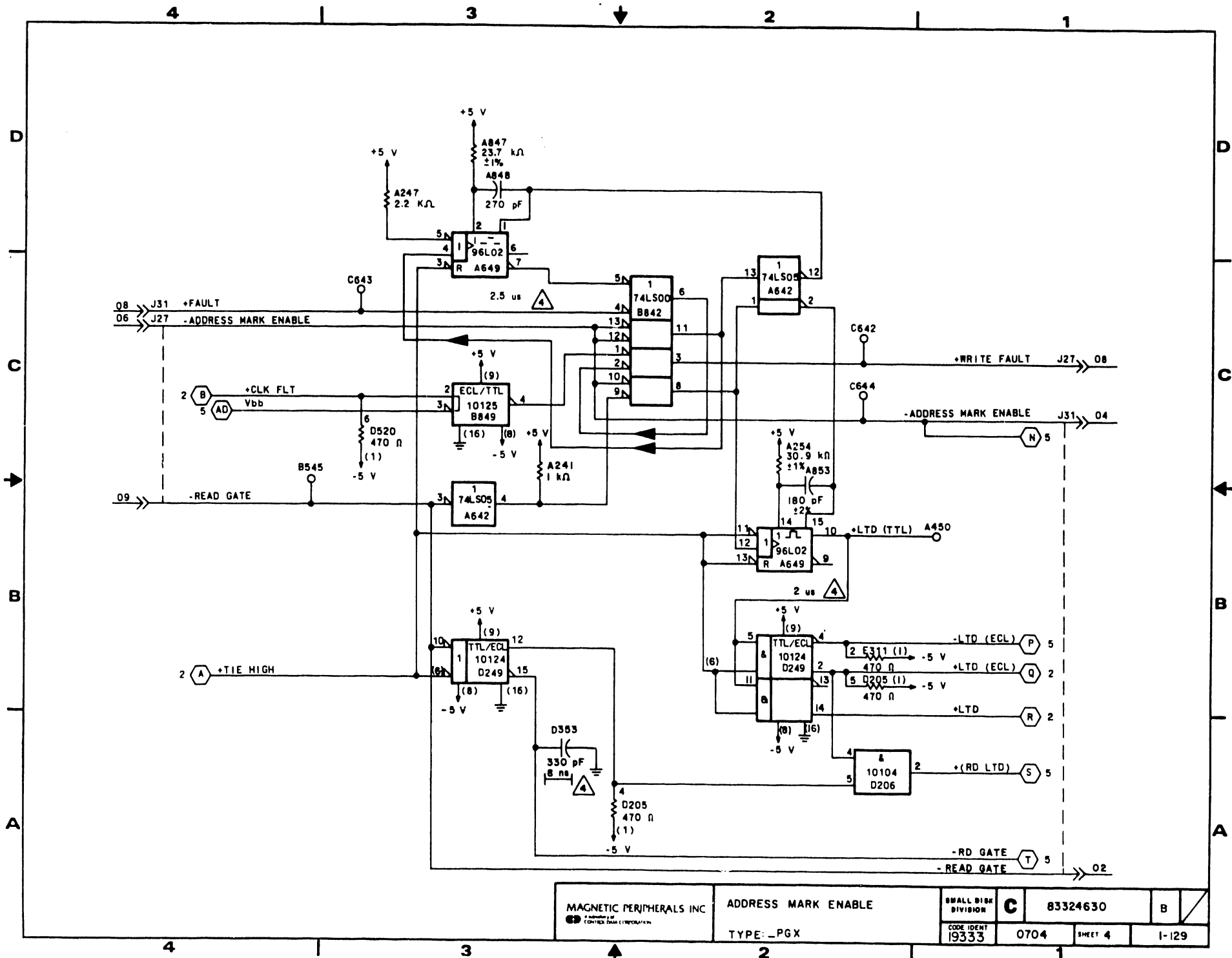

MAGNETIC PERIPHERALS INC <small>A DIVISION OF CONTROL DATA CORPORATION</small>	ADDRESS MARK ENABLE	SMALL DISK DIVISION	C	83324630	B
	TYPE: _PGX	CODE IDENT 19333	0704	SHEET 4	1-129

SIGNAL INPUTS

SINGLE CHANNEL UNITS		DUAL CHANNEL UNITS			
0206	P27-03	0212	P27-03	03	>> J27
0206	P27-04	0212	P27-04	04	>> J27
0808	J30-20	0808	J30-20	20	>> J31
0808	J30-21	0808	J30-21	21	>> J31
NC	-	NC	-	03	>> J46
NC	-	NC	-	02	>> J46

SIGNAL OUTPUTS

J27	>> 05	0204	P27-05
J46	>> 01	NC	-

LOGIC CROSS REFERENCE INFORMATION

PUB 83324630		REV B
CROSS REF NO 0705	PAGE 1-130	

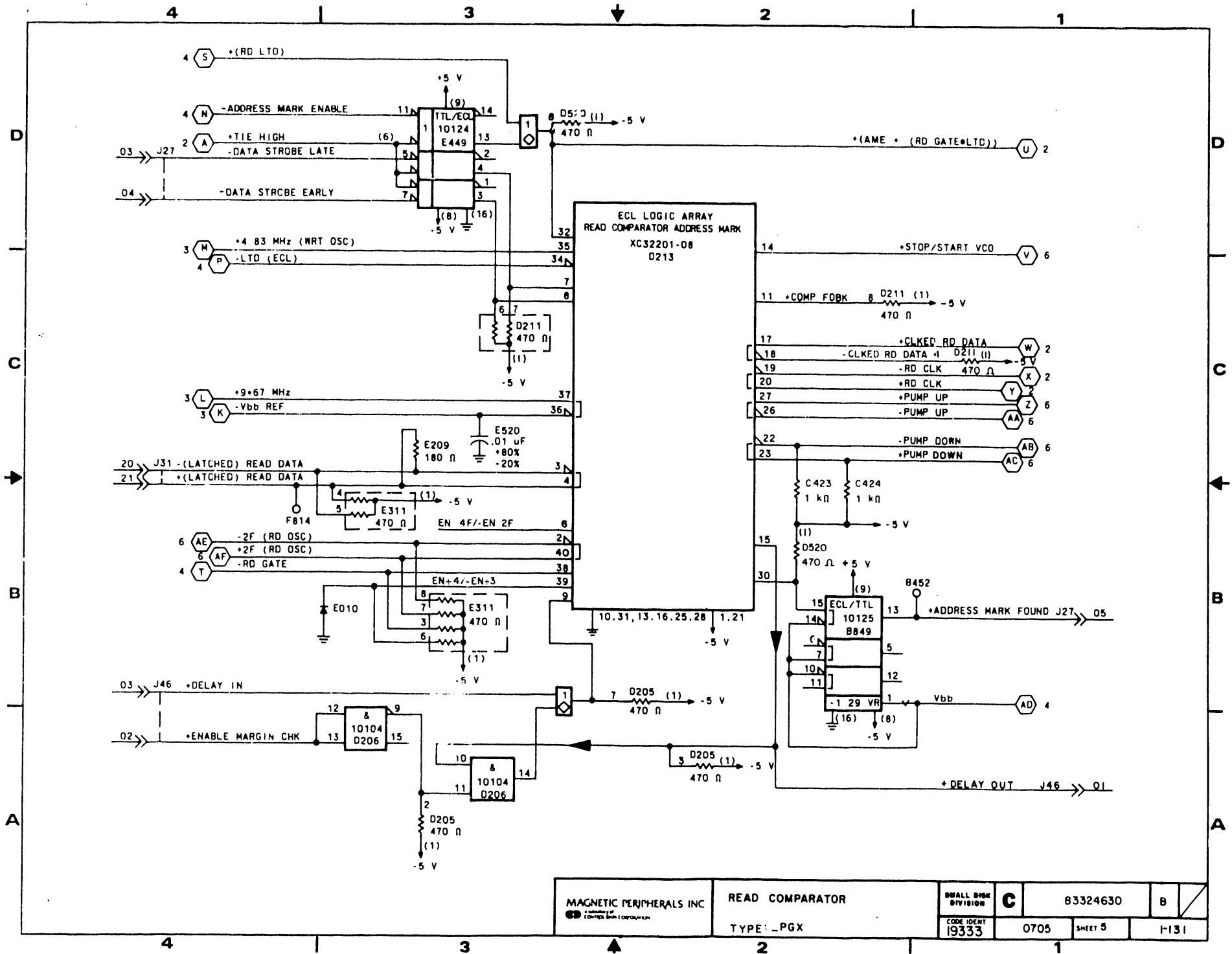

MAGNETIC PERIPHERALS INC. <small>a subsidiary of</small> CONTROL DATA CORPORATION	READ COMPARATOR		<small>SMALL DRUM DIVISION</small> C	83324630	B
	TYPE: _PGX		<small>CODE IDENT</small> I9333	0705	<small>SHEET</small> 5 <small>OF</small> 5

SIGNAL INPUTS

0402	J29-04	23	>>	J30	-----
0402	J29-03	24	>>	J30	-----
1002	J40-01	06	>>	J35	-----
NC	-	03	>>	J35	-----
NC	-	02	>>	J35	-----
NC	-	01	>>	J35	-----
1002	J40-02	05	>>	J35	-----
1002	J40-03	04	>>	J35	-----
0402	J29-02	25	>>	J30	-----
0402	J29-01	26	>>	J30	-----
NC	-	02	>>	J30	-----
NC	-	09	>>	J30	-----
0414	J29-17	10	>>	J30	-----
0414	J29-16	11	>>	J30	-----
0703	J31-13	13	>>	J30	-----
0703	J31-14	14	>>	J30	-----
0402	J29-15	12	>>	J30	-----
0402	J29-12	15	>>	J30	-----
NC	-	19	>>	J30	-----
NC	-	22	>>	J30	-----

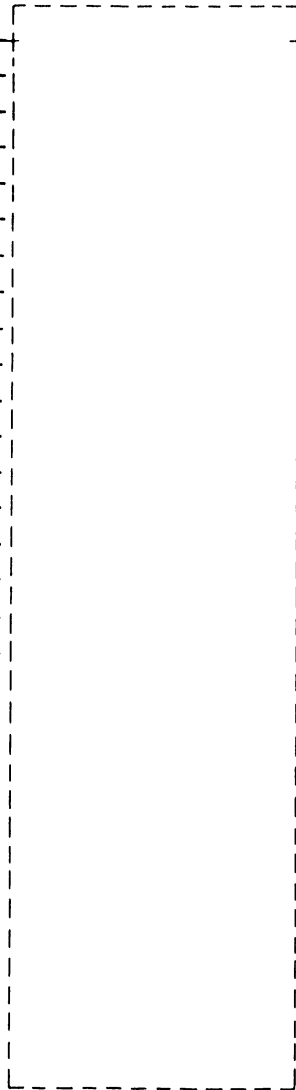

SIGNAL OUTPUTS

J32	>>	04	-----	0901	J42-04
J32	>>	05	-----	0901	J42-05
J32	>>	02	-----	0901	J42-02
J32	>>	08	-----	0901	J42-08
J32	>>	11	-----	0901	J42-11
J32	>>	03	-----	0901	J42-03

LOGIC CROSS REFERENCE INFORMATION

PUB		REV	
83324630		B	
CROSS REF NO	080i	PAGE	1-134

UNUSED LOGIC ELEMENTS		
ELEMENT	LOCATION	OUTPUT PIN(S)
7486	L135	8
7407	M044	12
10131	E647	14, 15

UNUSED TRANSISTOR PACKS		
ELEMENT	LOCATION	PIN(S)
MPQ2907	N326	8, 9, 10
MPQ2369	M226	1, 2, 3
CA3096	F122	7, 8, 9
CA3096	G422	7, 8, 9

FILTER CAPS ²			
1 uF ±80% -20%			
+15 V	+5 V	5 V	-15 V
E526	L952	D946	K427
K428	F645	E330	L622
L621	F708	F143	M618
M615	F717	F147	
	F722	F709	
	K436	F718	
	K447	DR10	
	M806	G134	
		G922	
		J826	
		J921	
		N315	
		M807	

UNUSED RESISTOR PACKS	
LOCATION	PIN(S)
D735	6, 7, 8
E047	5, 8
G336	2, 3, 8
J232	2
M443	6

PART NO RANGE
OO THRU 99

REV		PCO	DESCRIPTION	DIFF	DATE	CHKD	APP
01		1303032A	PRE-RELEASED		4-2-82		II
02		030308L	CHG VALUE & LOC	DLM	8-22-82	DGD	II
A		030308L	RELEASED	DLM	9-27-82	DGD	II
1		1303140	DELETE PINS	DLM	10-6-82	DGD	III
2		030313Z	ALL PIN SHFT REF	DLM	10-18-82	DGD	III
3		030313Z	CORRECTION	MJ	3-17-83		
4		030313Z	BRX TO CPFX	MJ	5-12-83		
5		0303199	DELETE PINS	MJ	10-4-83		

NOTES

1 UNLESS OTHERWISE SPECIFIED

ALL 14 PIN IC'S HAVE PIN 7 CONNECTED TO GROUND AND PIN 14 CONNECTED TO +5 V.

ALL 16 PIN IC'S HAVE PINS 1 AND 16 CONNECTED TO GROUND AND PIN 8 CONNECTED TO -5 V

ALL DIODES, 24553500

ALL TRANSISTORS, SPNP, 2N4258, 15185563.

ALL TRANSISTOR ARRAYS, NPN, MPQ2369, 50213300

ALL DELAY LINES 94262303

ALL DELAY LINES HAVE PIN 7 AND 8 CONNECTED TO GROUND.

ALL RESISTOR PACK RESISTORS, 1/8 W, ±3%.

ALL POTENTIOMETERS, 1/4 W, ±10%.

² SEE TABLE FOR 1 uF FILTER CAPACITOR LOCATIONS

³ TRANSISTOR ARRAY, PNP, MPQ2907, 50212700.

⁴ TRANSISTOR ARRAYS, NPN/PNP, CA3096, 50213100, PIN 16 TO -5 V.

⁵ DELAY TIME FOR REF ONLY.

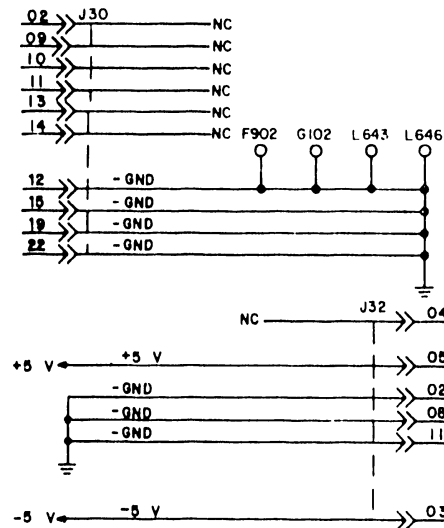
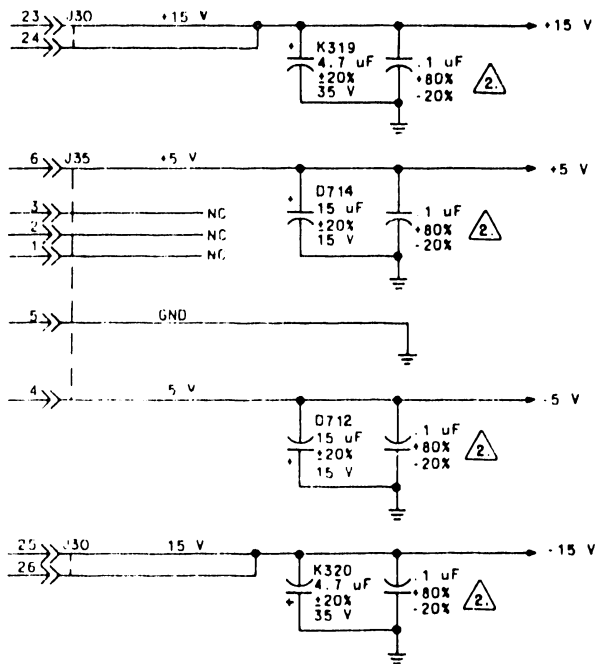

REFERENCE DRAWING				MAGNETIC PERIPHERALS INC		TITLE	
COMP ASSY 54332501				CORPORATION		SCHEMATIC DIAGRAM	
CTR 54332701				FIRST USED ON		DATA LATCH	
				NEXT ASSEMBLY		TYPE B/CPFX	
COMPONENTS EXCEPT AS NOTED				DWN F. AUDETTE		2/10/82	
RES	±5%	OHMS	1/4 W	ENGR	DG Dant	5/10/82	SMALL DISK DIVISION
CAP	±10%			MFG	J.R. Bnk	5-11-82	
IND	±5%			QA	K.M. Ant	8-30-82	
ZEN	±5%				P. Kupinski	8/31/82	
REV. NO. 19333						SIZE C	83324630
O801						SHEET 1 OF 8	
REF 54332601/3						PAGE 1-135	
PRODUCT RSD/F80							

SIGNAL INPUTS

0703 J31-16 ~~16~~ >> J30
 0703 J31-17 ~~17~~ >> J30
 0409 J29-09 ~~18~~ >> J30
 0902 J42-10 ~~10~~ >> J32
 0902 J42-09 ~~09~~ >> J32

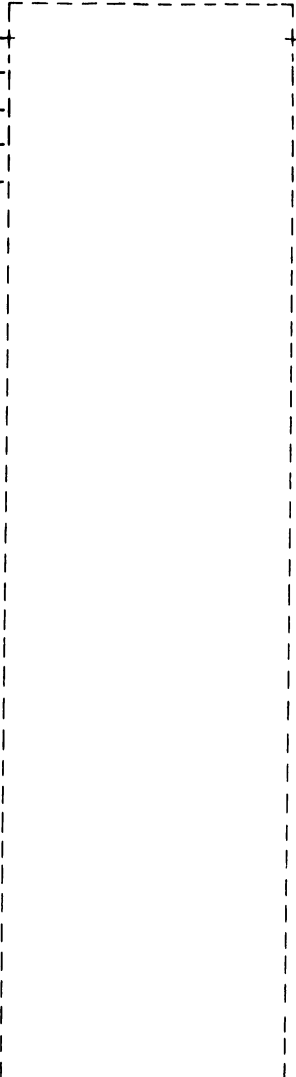

SIGNAL OUTPUTS

J33 >> 03 NC -
 J33 >> 02 NC -
 J33 >> 05 NC -
 J33 >> 01 NC -

LOGIC CROSS REFERENCE INFORMATION

PUR		83324630	REV	B
CROSS REF NO	0802	PAGE	1-136	

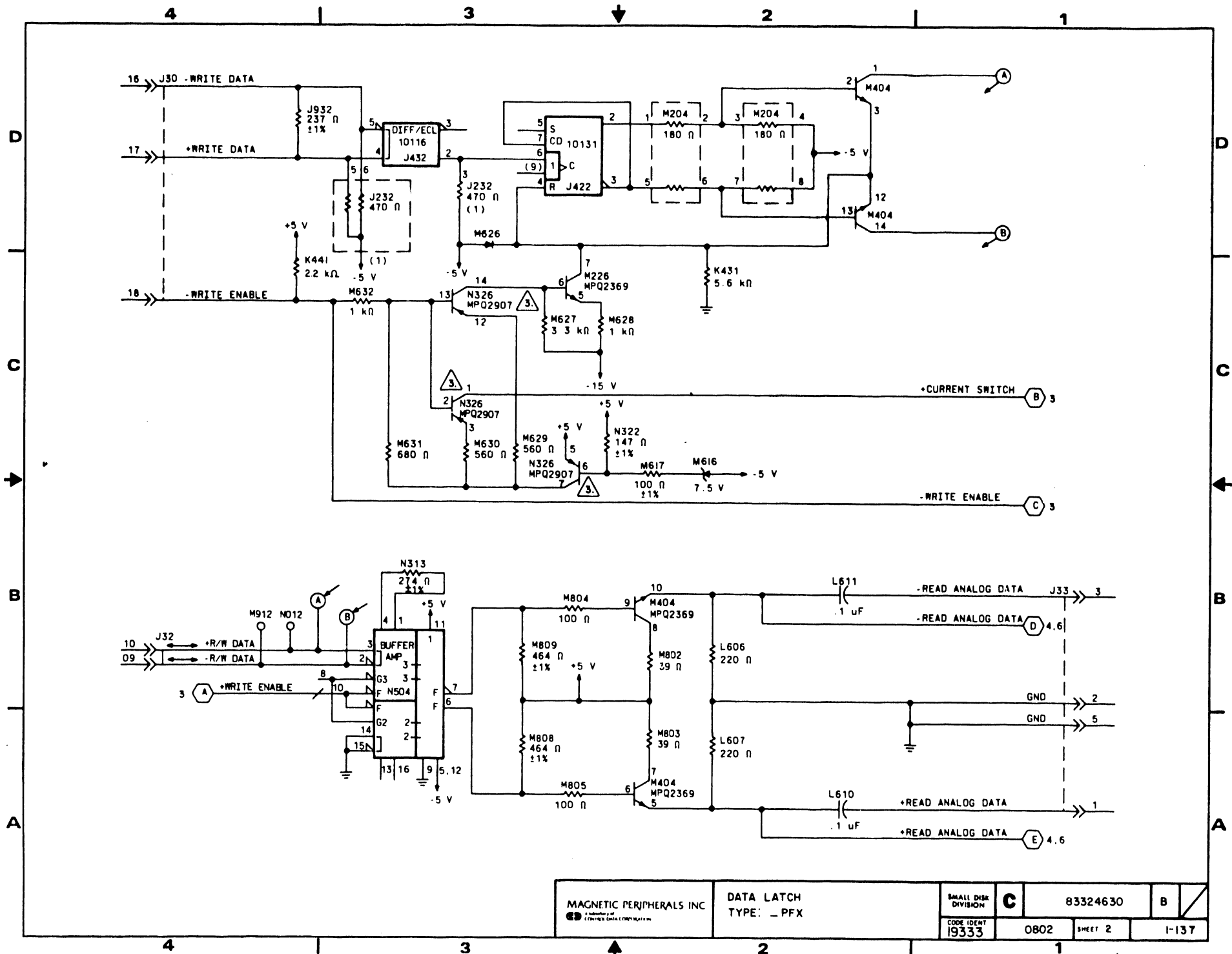

 <small>A Division of</small> CONTECH DATA CORPORATION	DATA LATCH TYPE: - PFX	SMALL DISK DIVISION	C	83324630	B
	CODE IDENT 19333	0802	SHEET 2	1-137	

SIGNAL INPUTS

0420 J29-21 -06-->>-J30
0902 J42-06 -06-->>-J32

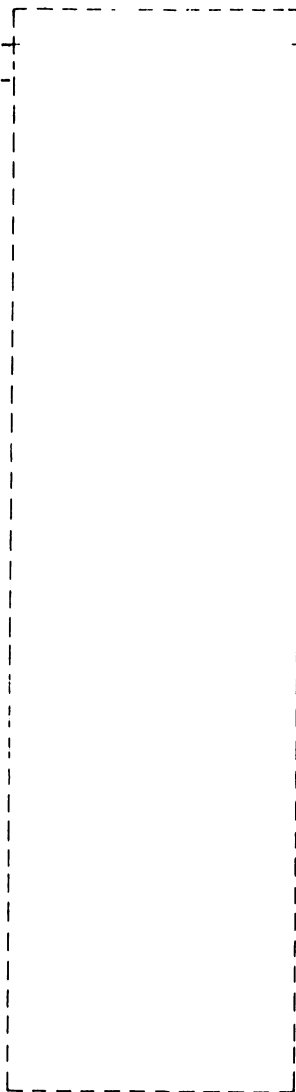

SIGNAL OUTPUTS

J32-->>-01- 0902 J42-01
J32-->>-07- 0902 J42-07
J30-->>-08- 0704 J31-08

LOGIC CROSS REFERENCE INFORMATION

PUB	83324630	REV	B
CROSS REF NO	0803	PAGE	1-138

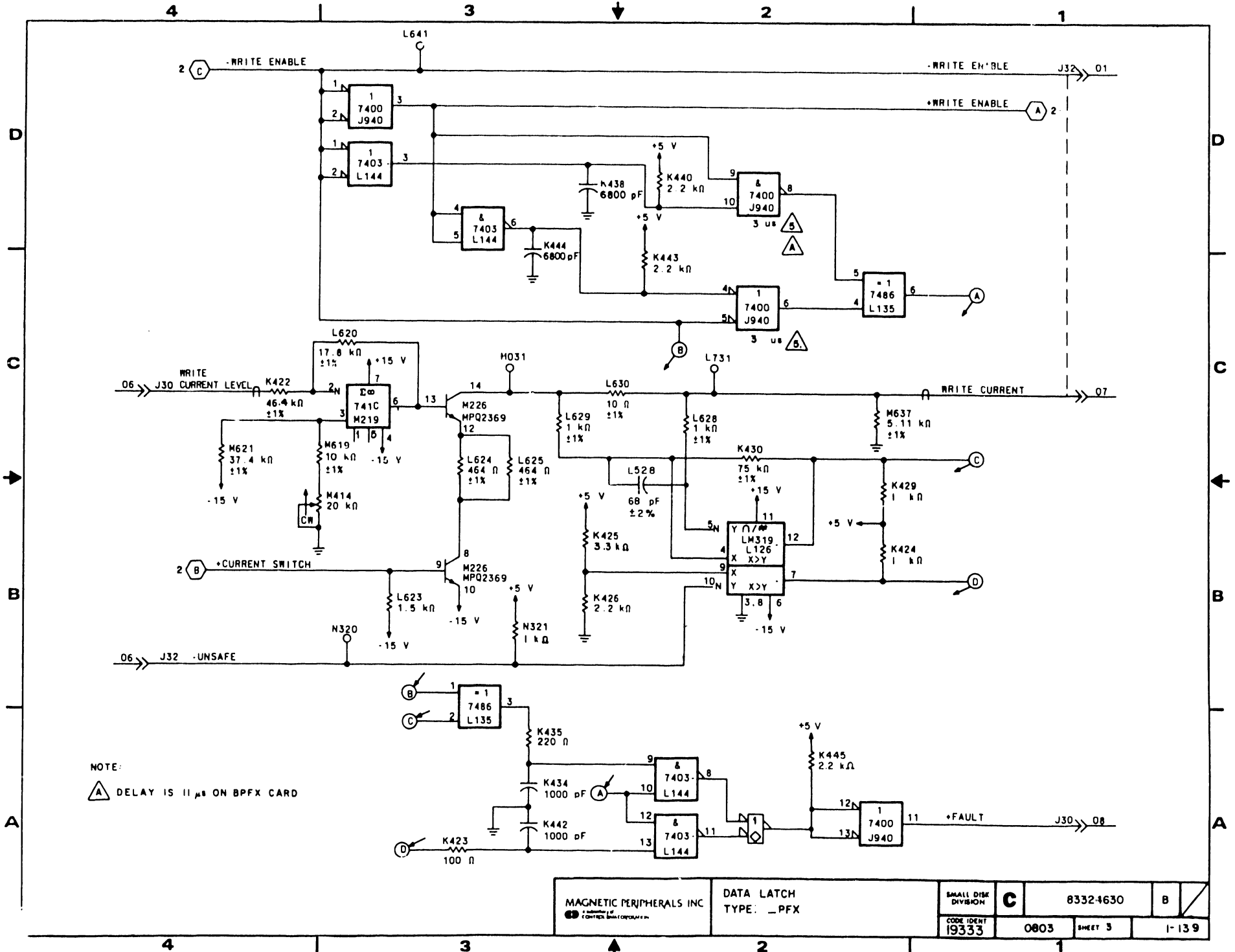

MAGNETIC PERIPHERALS INC. A DIVISION OF CONTROL DATA CORPORATION	DATA LATCH TYPE: -PFX	SMALL DISK DIVISION	C	8332-4630	B
		CODE IDENT 19333			

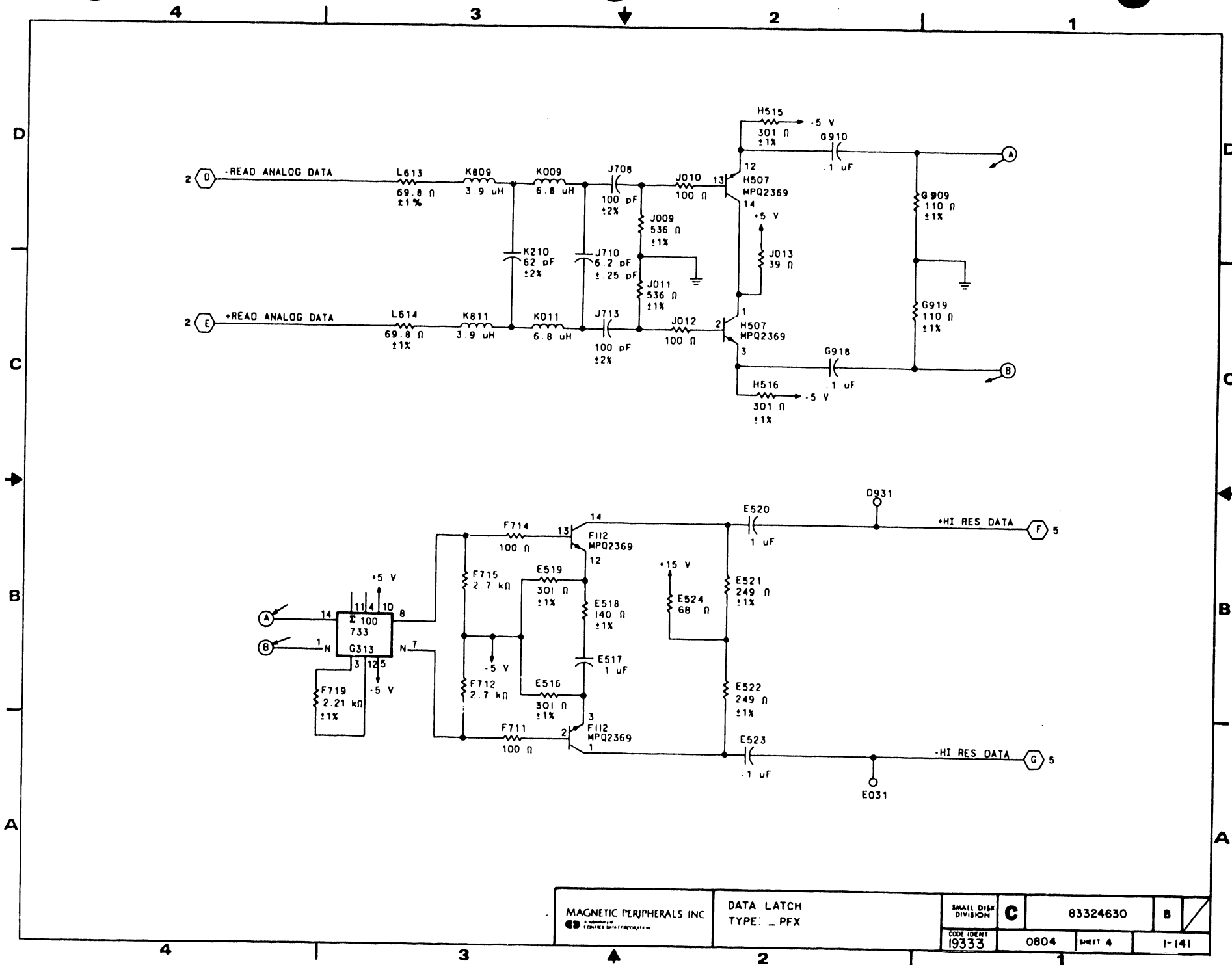

MAGNETIC PERIPHERALS INC <small>A Division of General Electric Company</small>	DATA LATCH TYPE: _ PFX	SMALL DISK DIVISION	C	83324630	B
		CODE IDENT 19333	0804	SHEET 4	I-141

SIGNAL INPUTS

0406 J29-26 01 >> J30
 0406 J29-24 03 >> J30
 0406 J29-22 05 >> J30
 0406 J29-20 07 >> J30

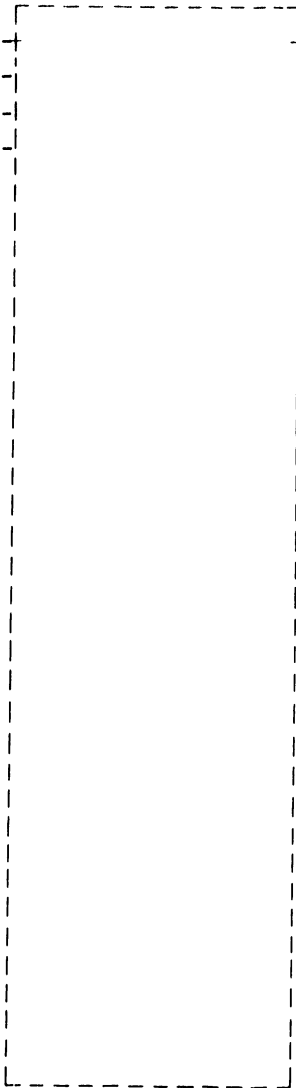

SIGNAL OUTPUTS

J32 >> 16 NC J42-16
J32 >> 14 0902 J42-1
J32 >> 15 0902 J42-15
J32 >> 13 0902 J42-13
J32 >> 12 NC J42-12

LOGIC CROSS REFERENCE INFORMATION

PUB		REV	
83324630		B	
CROSS REF NO	PAGE		
0805	1-142		

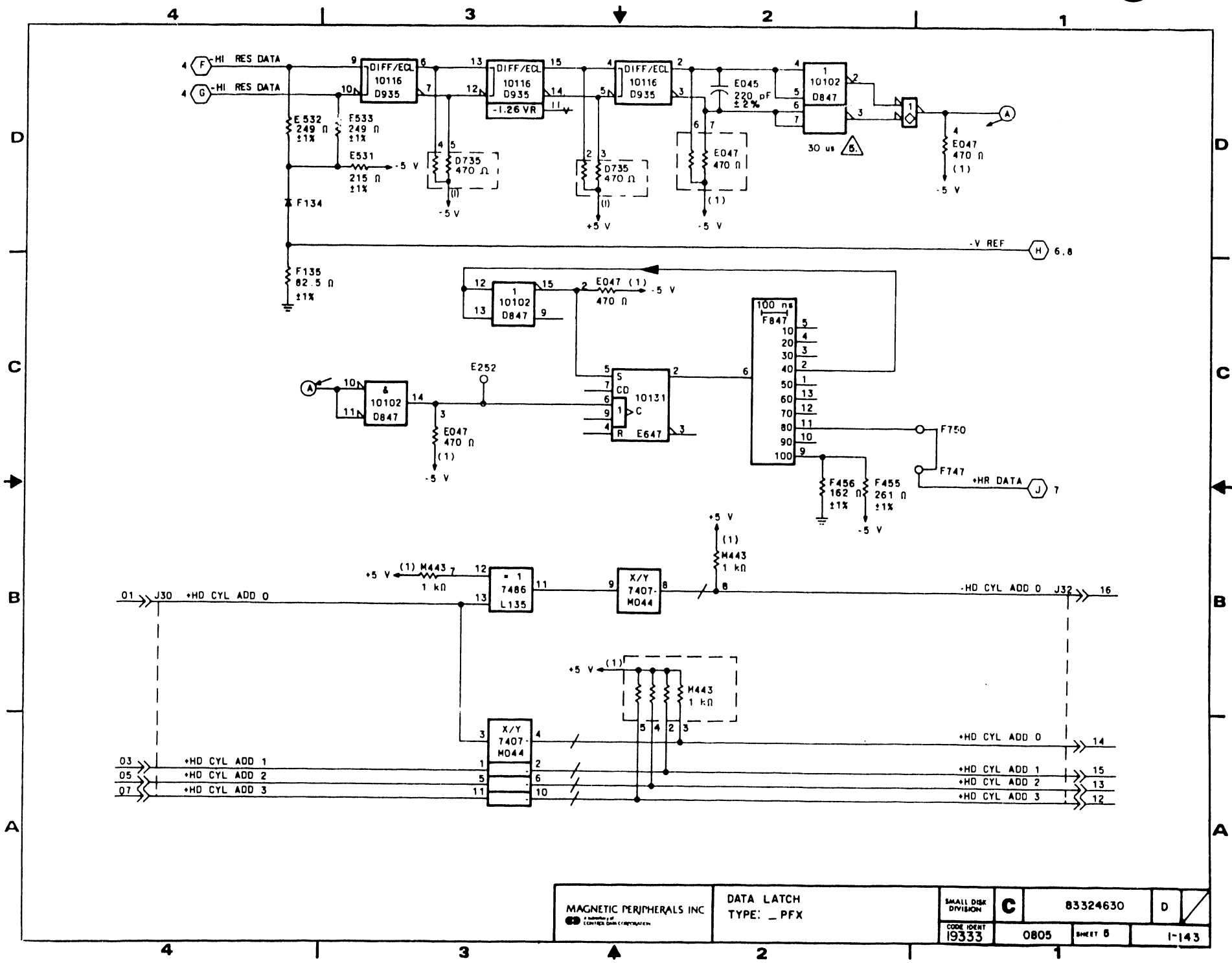

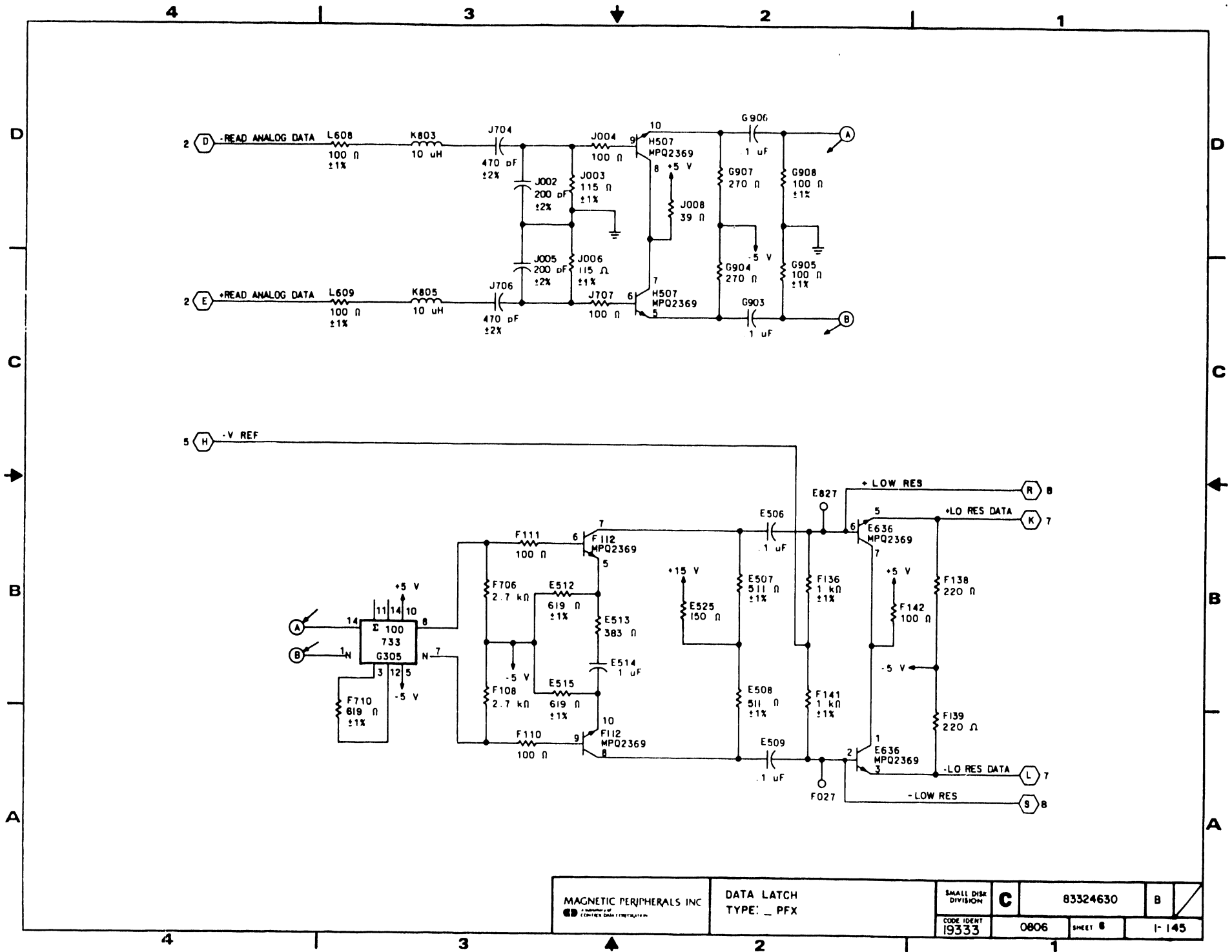

MAGNETIC PERIPHERALS INC
MEMBER OF
 CENTRAL DATA CORPORATION

DATA LATCH
 TYPE: _ PFX

SMALL DISK DIVISION	C	83324630	B
CODE IDENT 19333	0806	SHEET 8	1-145

SIGNAL INPUTS

SIGNAL OUTPUTS

0704 J31-04 04 >> J30

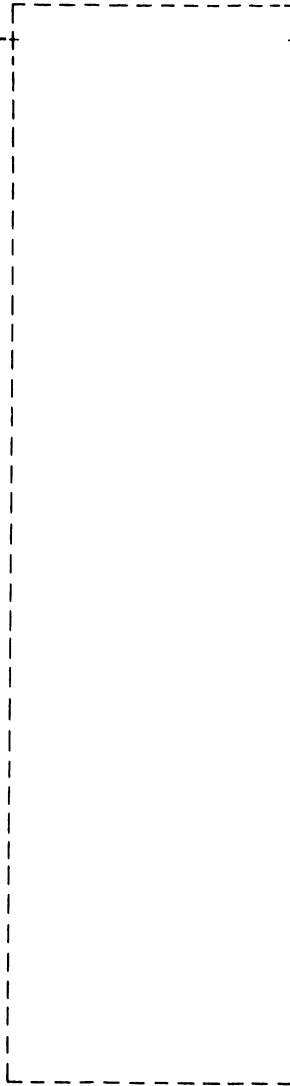

LOGIC CROSS REFERENCE INFORMATION

PUB	83324630	REV	B
CROSS REF NO	0807	PAGE	1-146

4 | 3 | 2 | 1

D
C
B
A

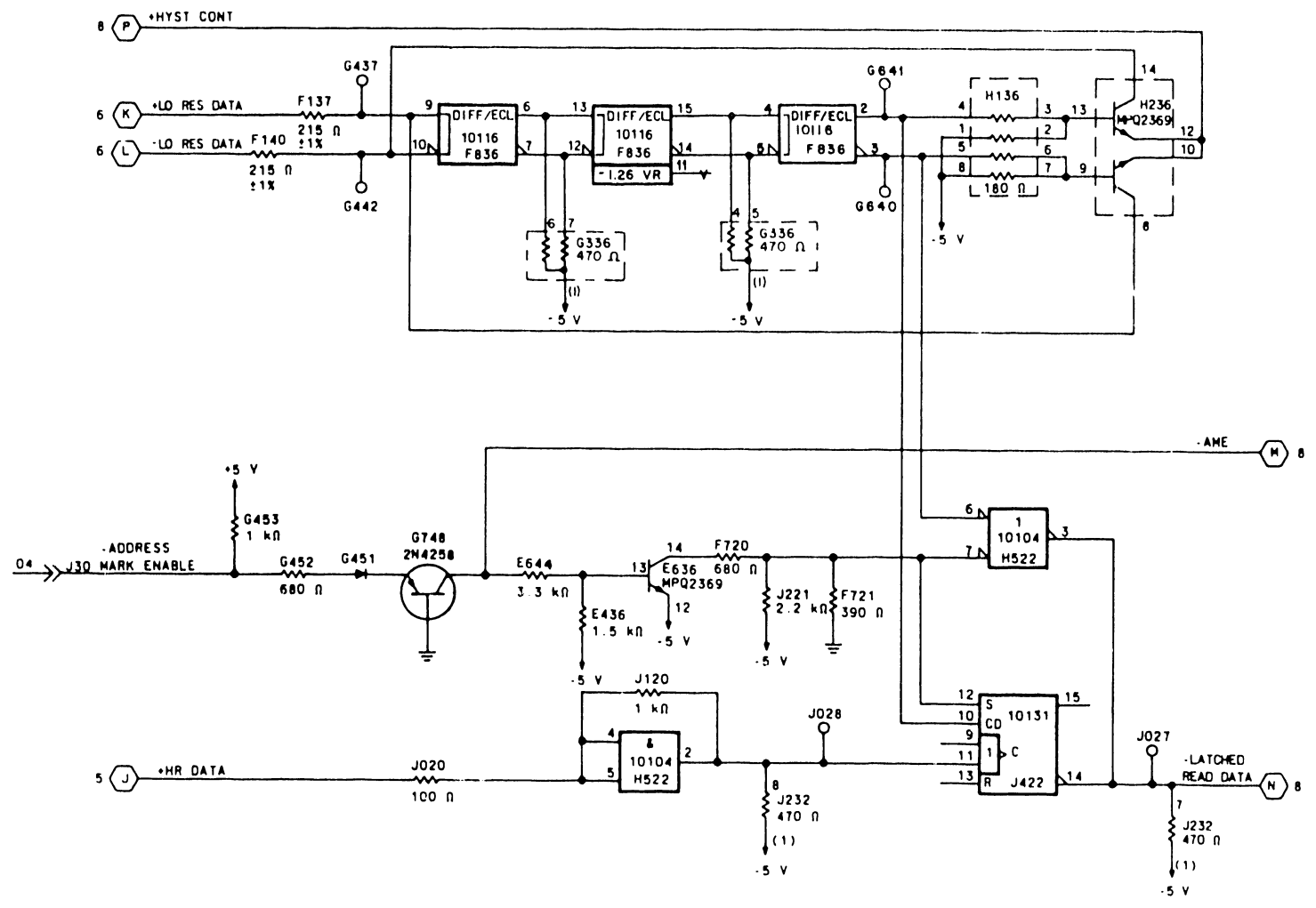

MAGNETIC PERIPHERALS INC <small>AN IRVING-CLOUD COMPANY</small>	DATA LATCH TYPE: - PFX		SMALL DISK DIVISION	C	83324630	B
	CODE IDENT I9333	0807	SHEET 7	1-147		

4 | 3 | 2 | 1

SIGNAL INPUTS

SIGNAL OUTPUTS

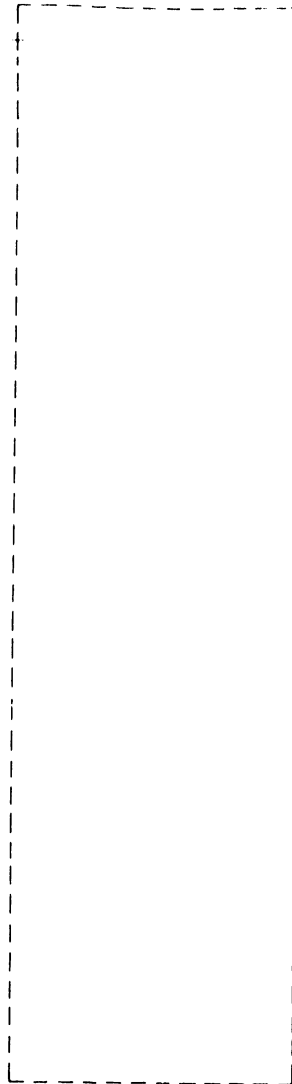

J30 >> 21 0705 J31-21
J30 >> 20 0705 J31-20

LOGIC CROSS REFERENCE INFORMATION

PUB		REV	
83324630		B	
CROSS REF NO	0808	PAGE	1-148

SIGNAL INPUTS

0801 J32-05 05 ->> J42
0801 J32-02 02 ->> J42
0801 J32-04 04 ->> J42
0801 J32-08 08 ->> J42
0801 J32-11 11 ->> J42
0801 J32-03 03 ->> J42

SIGNAL OUTPUTS

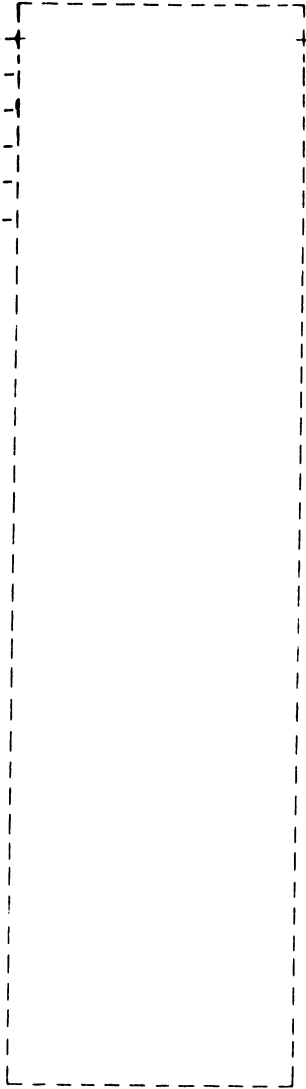

LOGIC CROSS REFERENCE INFORMATION

PUB	83324630	REV	B
CROSS REF NO	0901	PAGE	1-150

PART NO RANGE	REVISION RECORD						
	REV	ECO	DESCRIPTION	DRFT	DATE	CHKD	APP
00 THRU 99	A	DJ23000	RELEASED	MJ	9/9/82	JJ-LJ	

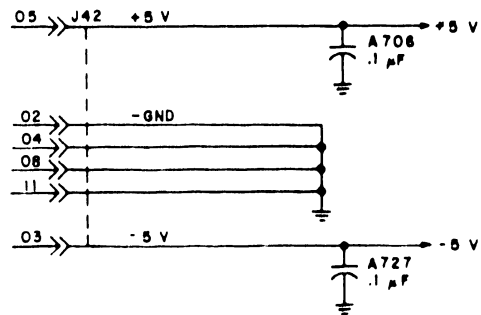

REFERENCE DRAWING				MAGNETIC PERIPHERALS INC		TITLE				
COMP ASSY 54331301				FIRST USED ON		SCHEMATIC DIAGRAM				
				PASAI - A		R/W PREAMP				
				NEXT ASSEMBLY		TYPE : CPCX				
COMPONENTS EXCEPT AS NOTED				DWN	M A FRANCE	11-10-81	SIZE			
RES	5 1%	OHMS	1/4 W	CHKD	DG Donat	4-30-82	SMALL ONE DIVISION	C	83324630	B
CAP	50% - 20%			ENGR	F.R. Bost	4-16-82				
				MFG						
				QA						
				FORM NO		0901		SHEET 1 of 2		PAGE 1-151
				19333		0901		1		PRODUCT RSD

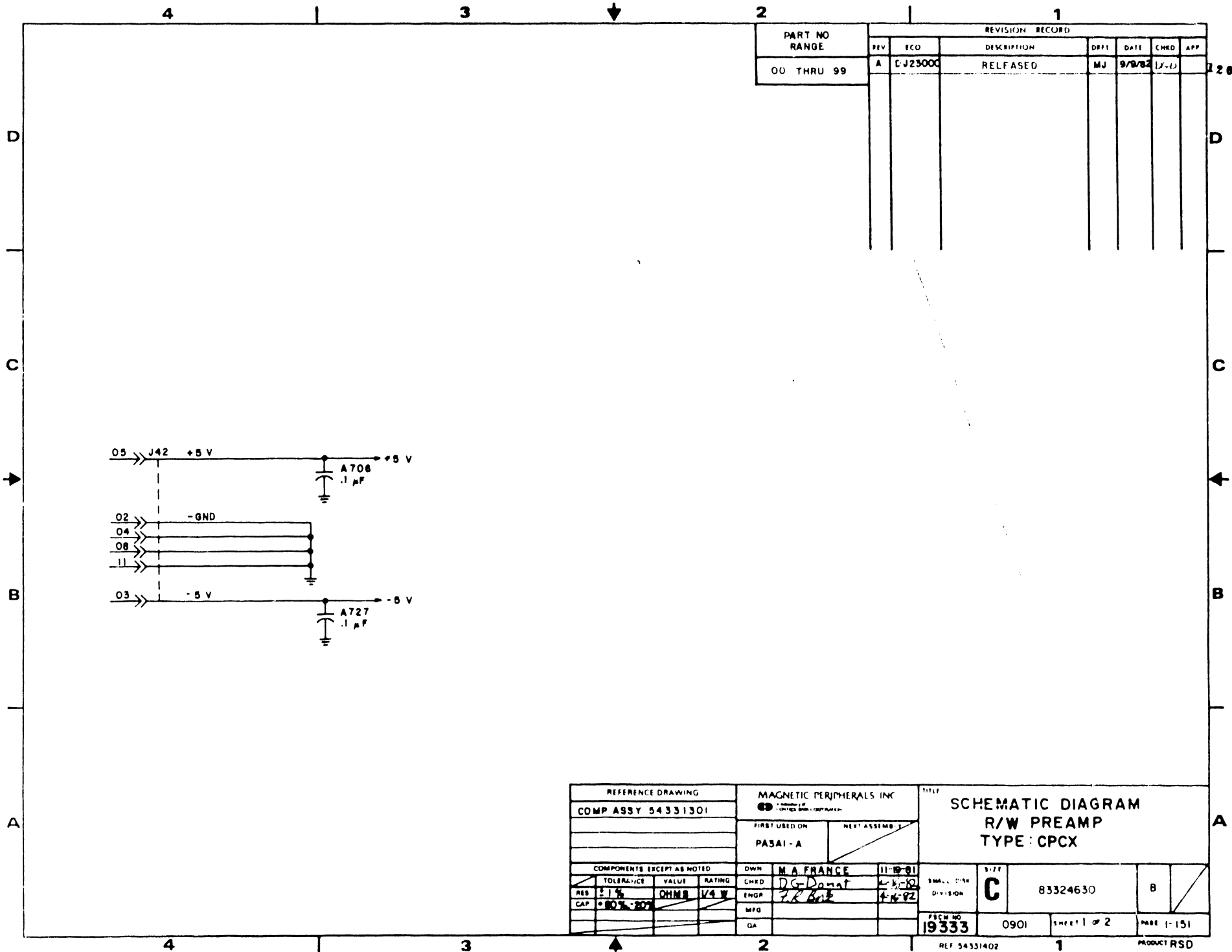

SIGNAL INPUTS

0805 J32-13 13 -> J42
 0805 J32-15 15 -> J42
 0805 J32-14 14 -> J42
 0803 J32-01 01 -> J42
 0803 J32-07 07 -> J42

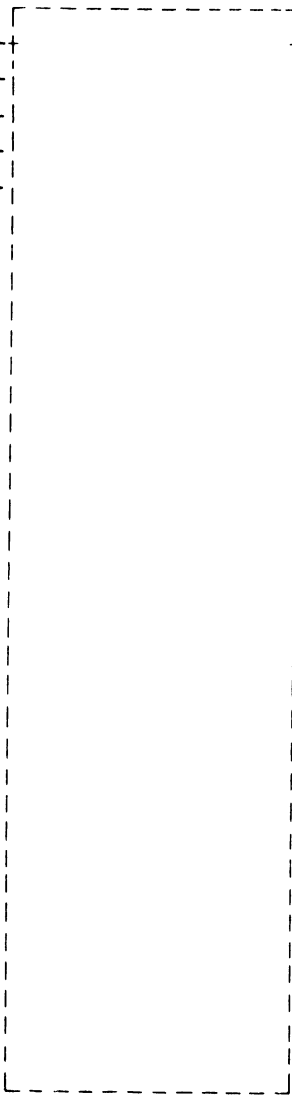

SIGNAL OUTPUTS

J42 -> 09 0802 J32-09
 J42 -> 10 0802 J32-10
 J42 -> 06 0803 J32-06

LOGIC CROSS REFERENCE INFORMATION

PUB 83324630		REV B
CROSS REF NO 0902	PAGE 1-152	

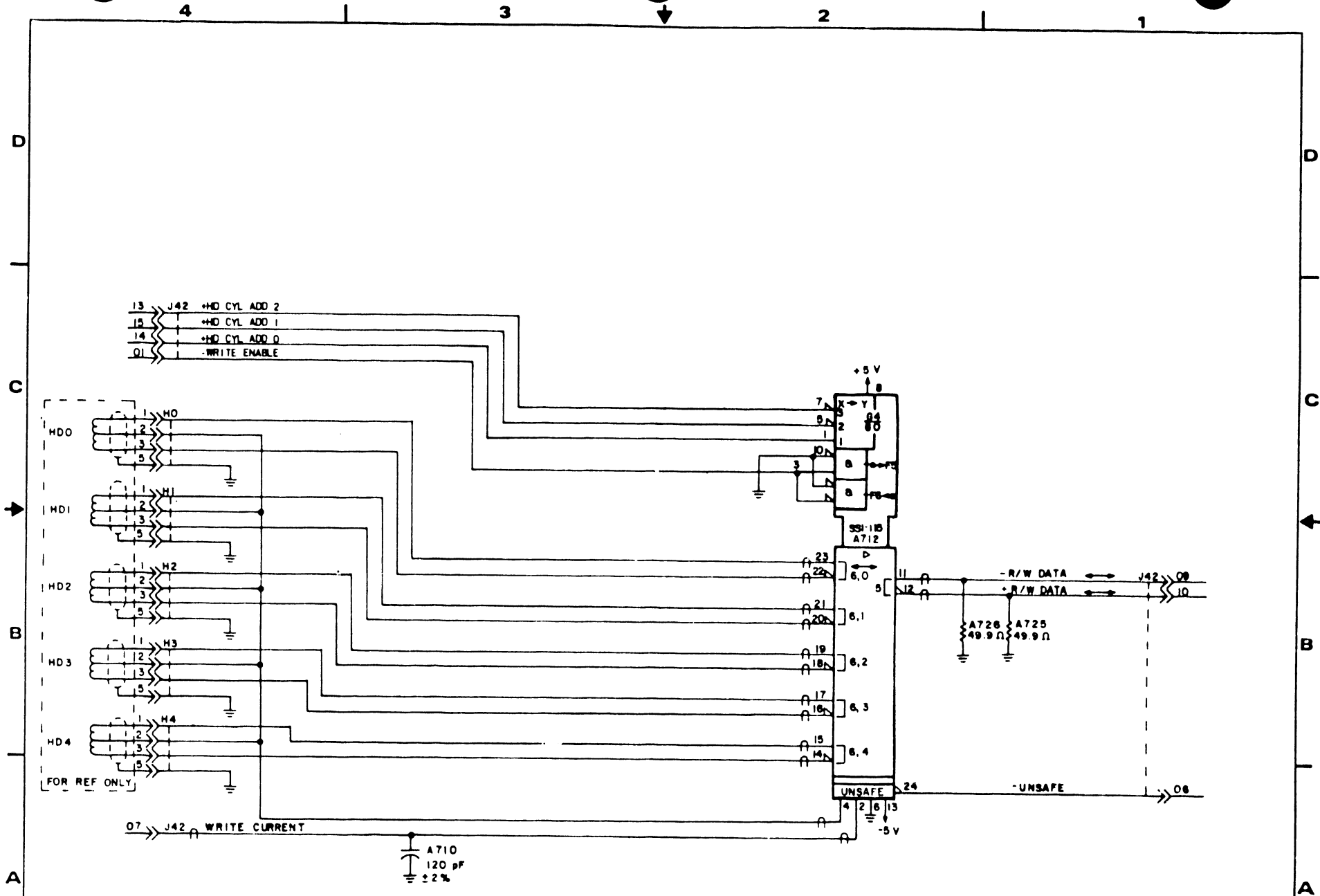

MAGNETIC PERIPHERALS INC. A Division of General Electric Company	SCHEMATIC DIAGRAM R/W PREAMP TYPE PCX		SMALL DSP DIVISION	C	83324630	B
	CODE IDENT 19333	0902	SHEET 2	1-153		

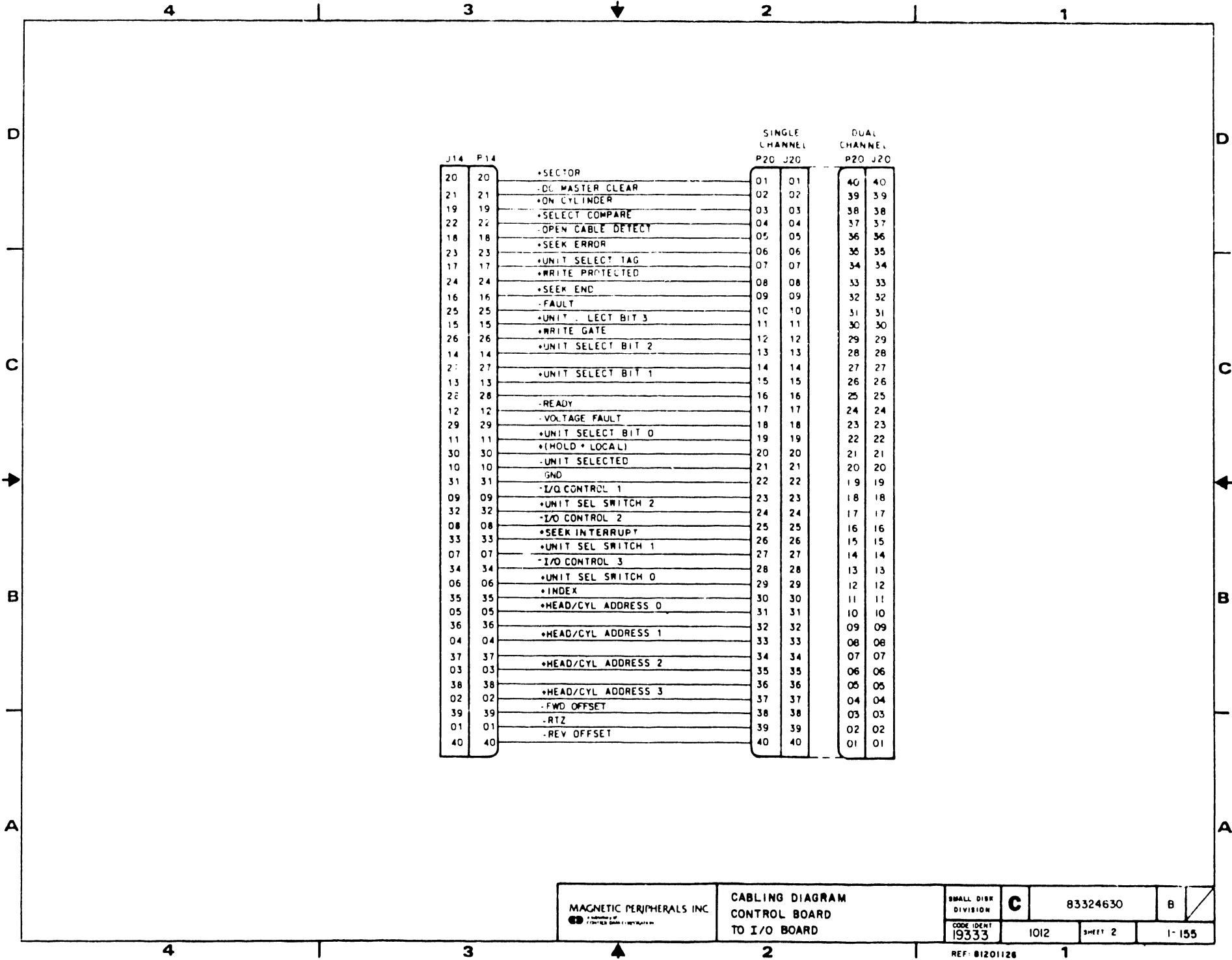

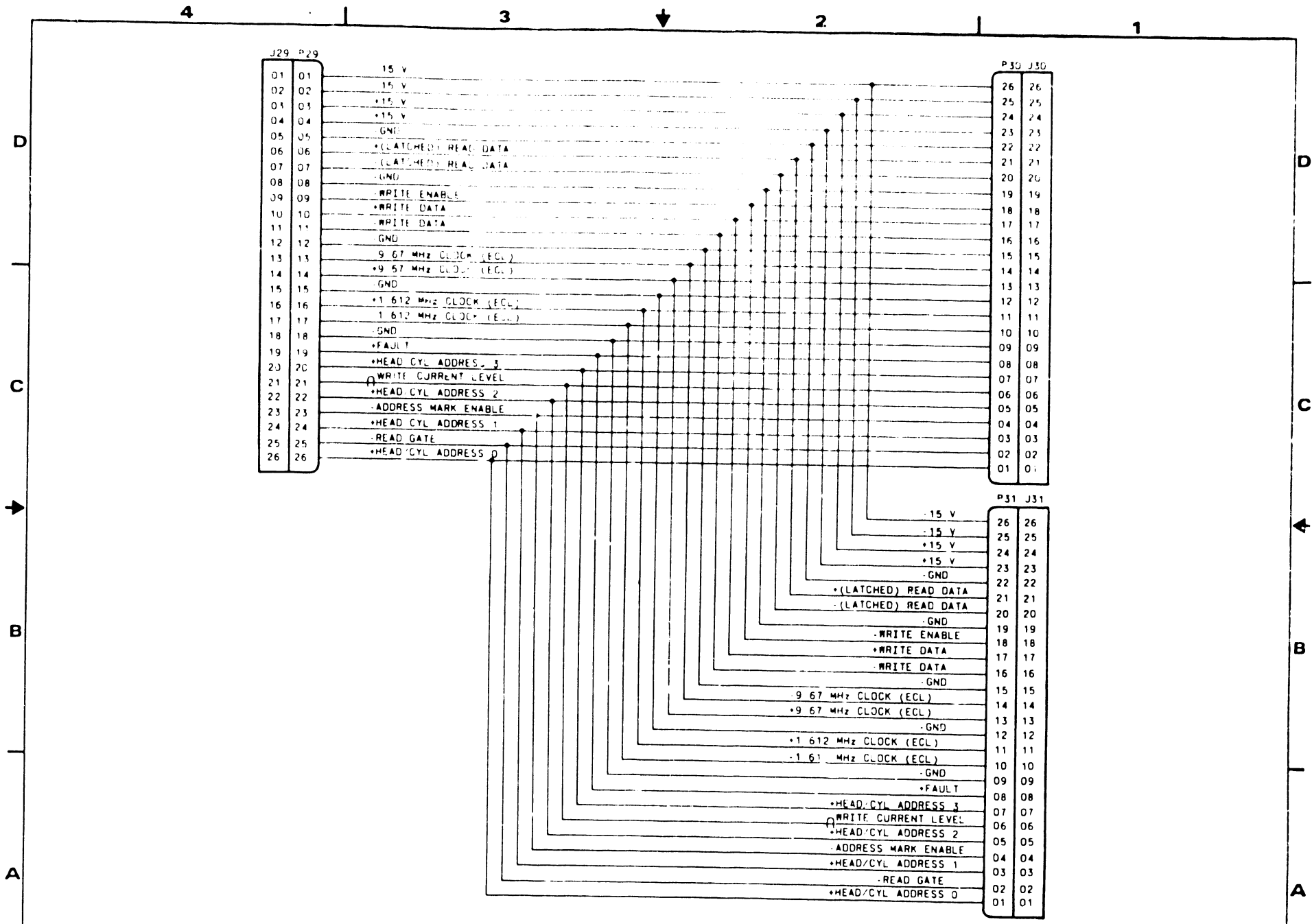

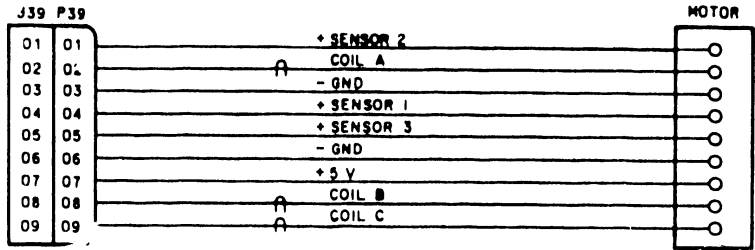
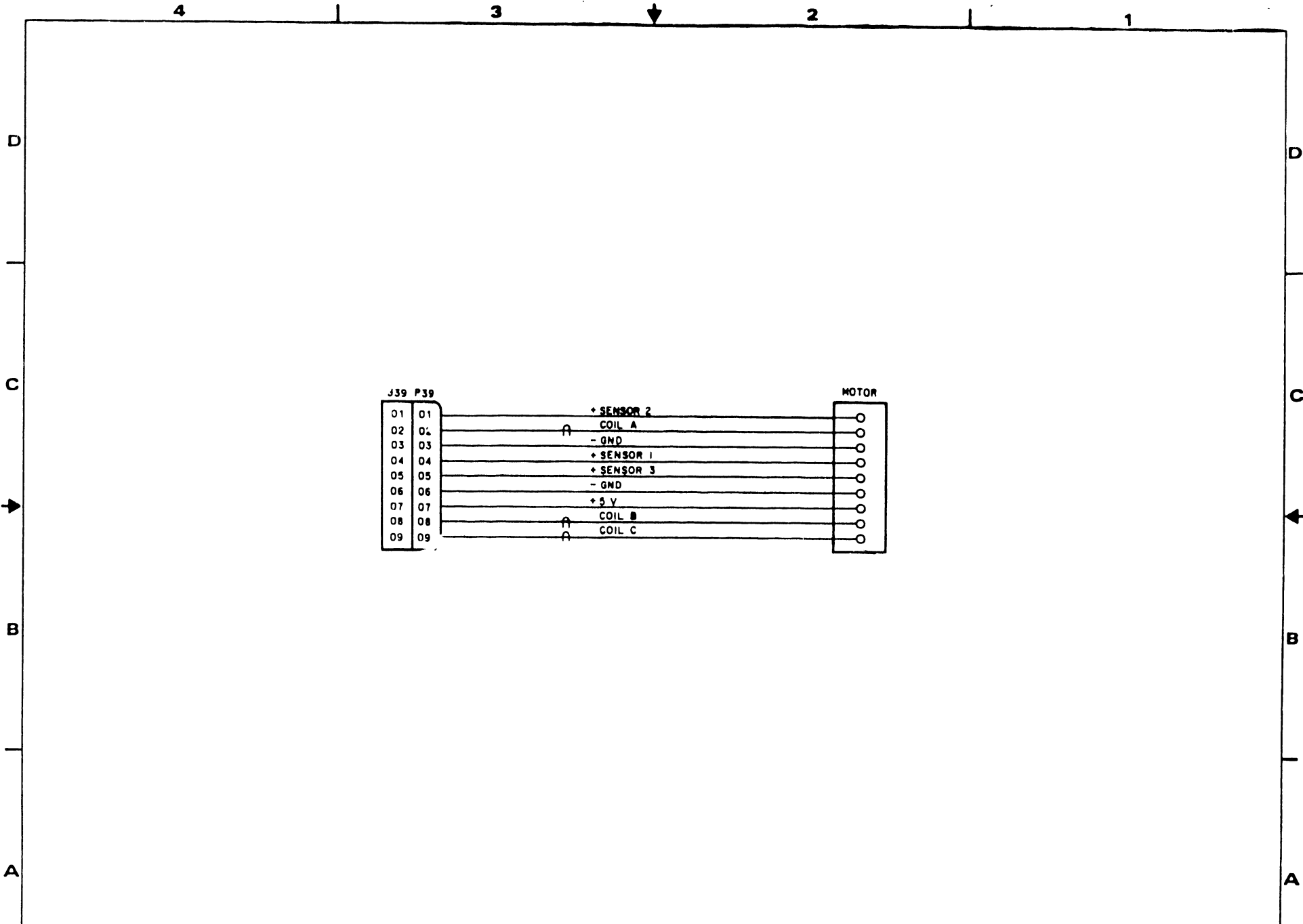

SIGNAL INPUTS

0402	J25-01	01	>>	P25
0402	J25-04	04	>>	P25
0409	J25-06	06	>>	P25
0409	J25-07	07	>>	P25
0402	J25-10	10	>>	P25

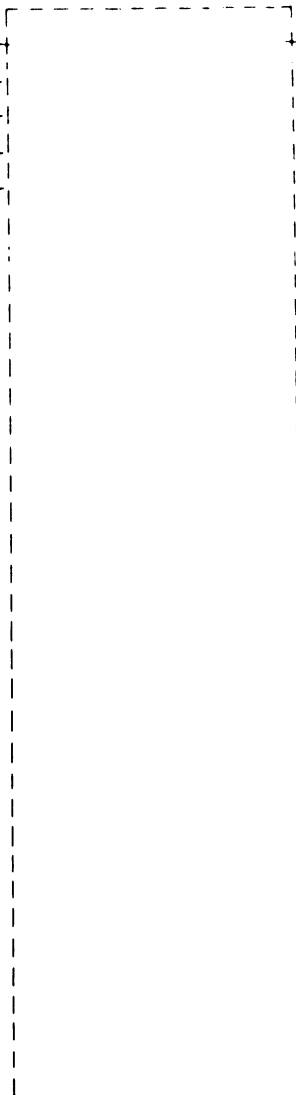

SIGNAL OUTPUTS

P25	>>	02	0407	J25-02
P25	>>	03	0409	J25-03
P25	>>	05	0406	J25-05
P25	>>	08	0407	J25-08
P25	>>	09	0410	J25-09

LOGIC CROSS REFERENCE INFORMATION

PUB	83324630	REV	B
CROSS REF NO	1042	PAGE	1-158

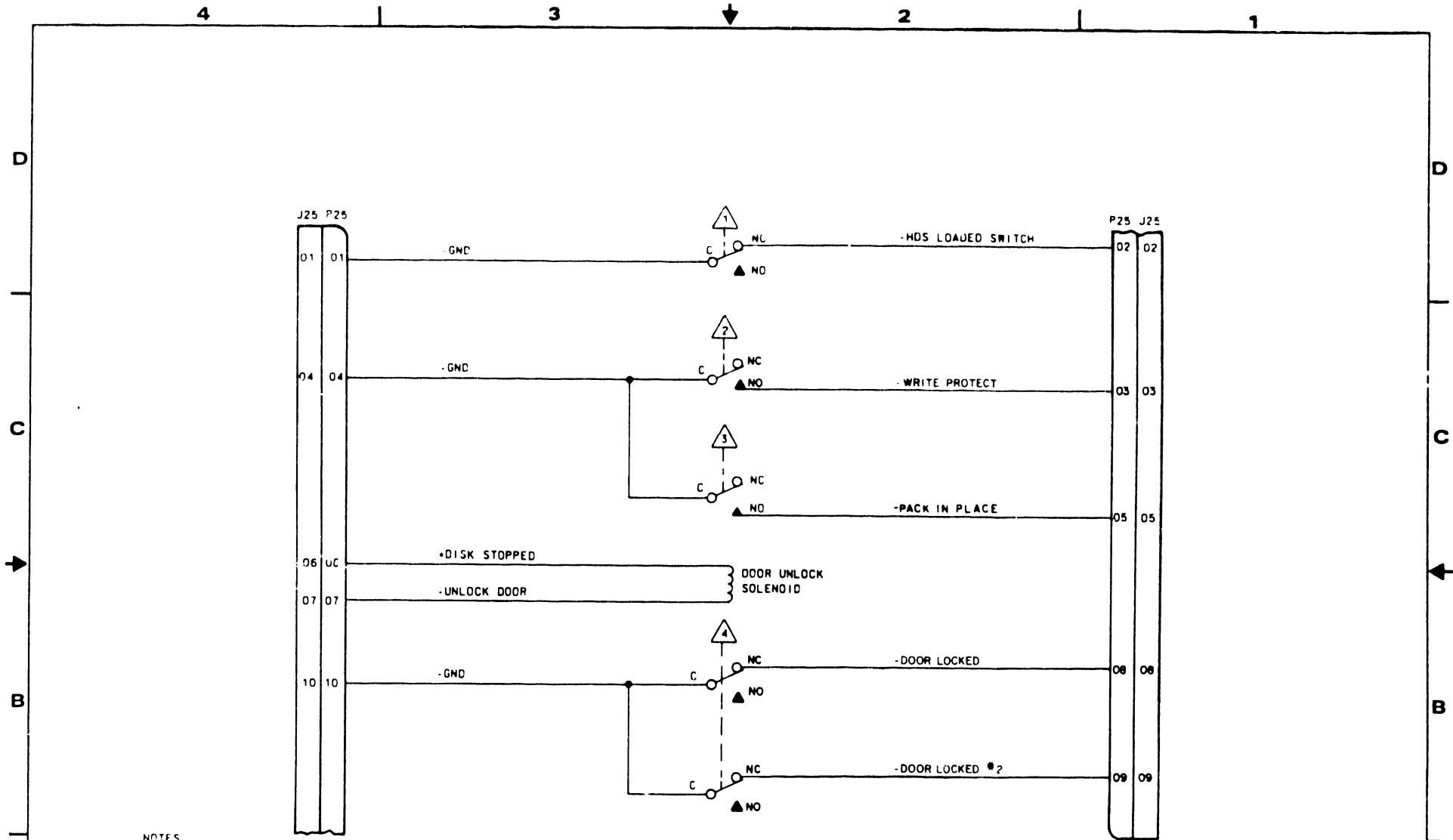

NOTES

- △ 1 SWITCH ACTIVATED BY CARRIAGE BEING RETRACTED.
- △ 2 SWITCH ACTIVATED BY WRITE PROTECT TAB ON CARTRIDGE
- △ 3 SWITCH ACTIVATED WHEN CARTRIDGE IS IN PLACE.
- △ 4 SWITCH ACTIVATED WHEN DOOR IS UNLOCKED

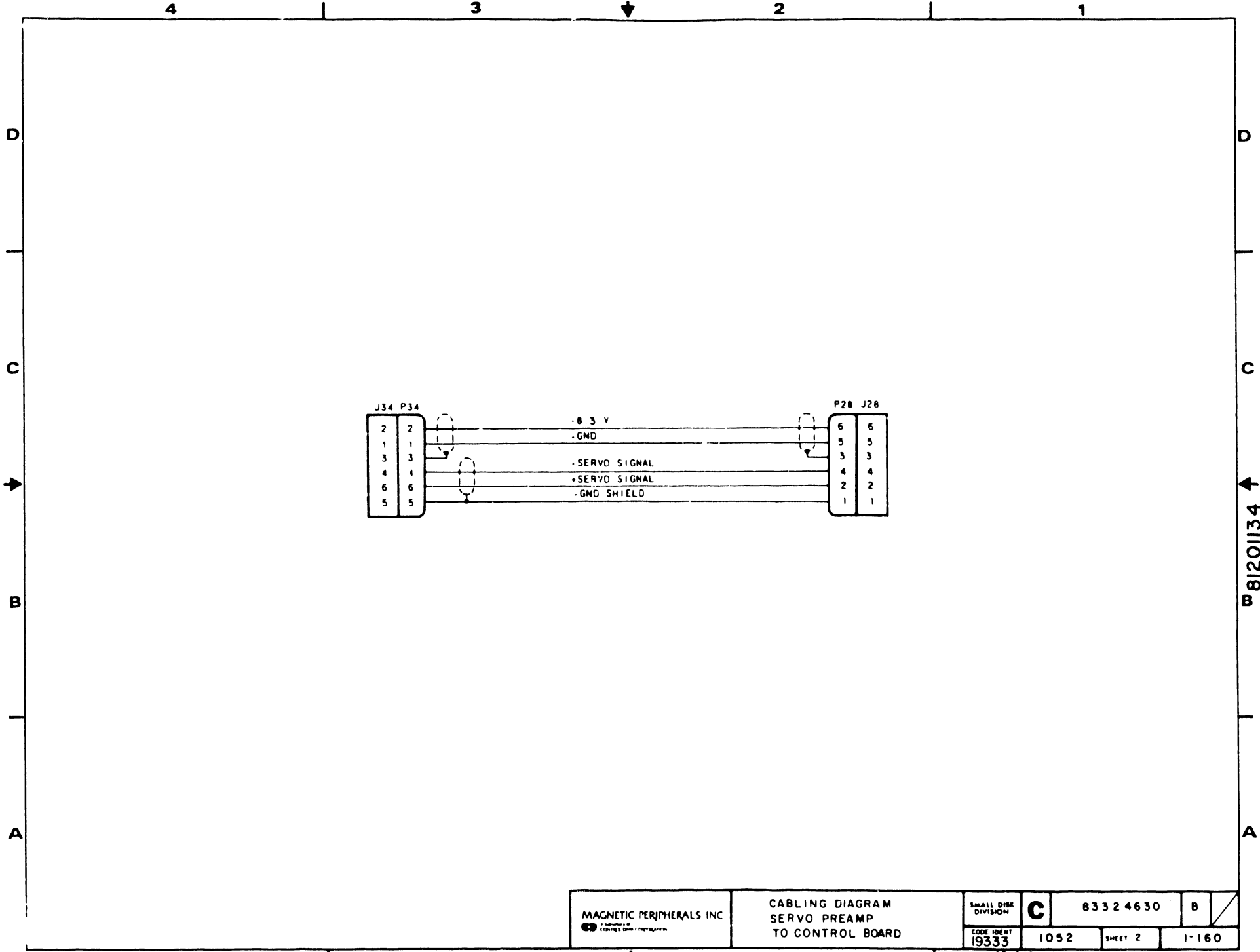

REF 81201134

4

3

2

1

D

D

C

C

B

81201133 ↑

A

A

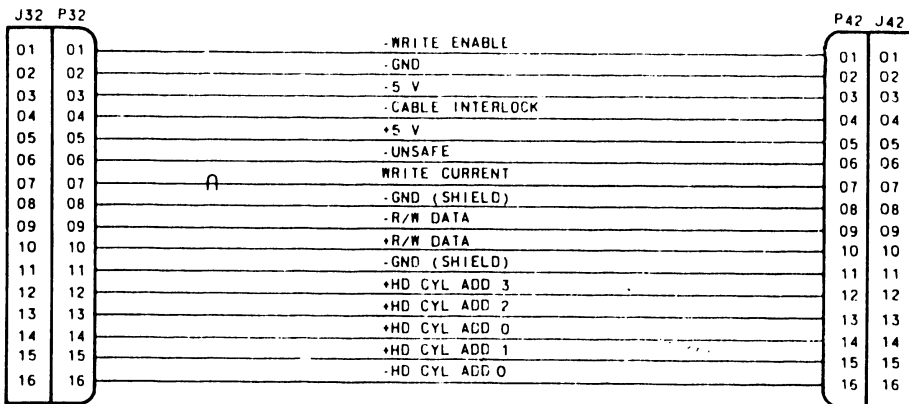

4

3

2

END