

2236 DE TERMINAL

COMPANY PROPRIETARY STATEMENT

This document is the property of Wang Laboratories, Inc. All information contained herein is considered Company Proprietary, and its use is restricted solely to assisting you in servicing Wang products. Neither this document nor its contents may be disclosed, copied, revealed, or used in whole or in part for any other purpose without the prior written permission of Wang Laboratories, Inc. This document must be returned upon request of Wang Laboratories, Inc.

**Customer Engineering
Product Maintenance Manual**

741-0476

COMPANY CONFIDENTIAL

PREFACE

This document is the Product Maintenance Manual (PMM) for the Wang 2236 DE Terminal. The manual is organized in accordance with Customer Engineering Technical Documentation's approved PMM outline. The scope of this manual reflects the type of maintenance philosophy selected for this product.

The purpose of this manual is to provide the Wang-trained Customer Engineer (CE) with sufficient instructions to operate, troubleshoot, and repair the 2236 DE Terminal. The manual will be updated on a regular schedule or as necessary. Such updates will be published either as Publication Update Bulletins (PUBs) or as full revisions.

Third Edition (October, 1985)

This edition of the 2236 DE Terminal PMM manual obsoletes document 729-0476 and 729-0476-1. Use of the material in this document is authorized only for the purpose stated in the Preface, above.

© Copyright 1979, Wang Laboratories, Inc.

CUSTOMER ENGINEERING

PUBLICATION UPDATE BULLETIN

DATE: 12/21/83

3401

PUB to 729 - 0476

2236DE TERMINAL

REASON FOR CHANGE:

THIS PUB UPDATES THE 2236DE TERMINAL SN# 181 TO INCLUDE THE ILLUSTRATED PARTS BREAKDOWN (IPB) AND THE PARTS LIST.

WANG

LABORATORIES, INC

ONE INDUSTRIAL AVENUE, LOWELL, MASSACHUSETTS 01851 TEL (617) 459-5000, TWX 710 343-6769, TELEX 94-7421

729-0476-1

PRINTED IN U.S.A.

TABLE OF CONTENTS

<u>SECTION</u>	<u>SUBJECT</u>	<u>PAGE</u>
1.0	General Description	1
1.1	CRT and Keyboard	2
1.2	Chassis Controls	5
1.3	Specifications	5
2.0	Site Preparation	6
3.0	Unpacking and Installation	6
3.1	Voltage and Frequency Selection	7
3.2	Voltage Checks and Adjustments	9
3.3	Video Display Adjustments	13
3.4	Terminal Interconnection	15
3.5	Terminal Controllers	15
3.6	Controller Switch Settings	17
3.7	Baud Rate Selection	18
4.0	Power-Up Diagnostics	18
5.0	Preventive Maintenance	20
6.0	Major Assembly Removal and Replacement	21
6.1	CRT Anode Discharge Procedure	21
6.2	Terminal Electronics PCB Removal	21
6.3	CRT Chassis Assembly Removal	22
6.4	Monitor Electronics PCB Removal	23
6.5	KEYTRONICS Keyboard Assembly Removal	23
6.6	Power Transformer Removal	23
7.0	Standard Features	27
7.1	Character Display Attributes	27
7.2	Alternate Graphics Set Selection	28
7.3	Box Graphics	29
7.4	Screen Dump	30
8.0	Cable Part Numbers	31
9.0	Illustrated Parts Breakdown	33
10.0	Schematics	43

LIST OF ILLUSTRATIONS

<u>FIGURE</u>	<u>TITLE</u>	<u>PAGE</u>
1	KEYTRONICS Keyboard	4
2	CRT Outline	8
3	CRT and Cover	10
4	Voltage Select Switch	10
5	Jumper Locations (210-7592 PCB) and Baud Rate Selection Switch	11
6	Close-Up of R66 and R72	12
7	210-7456 PCB	14
8	Rear of Terminal	16
9	Terminal Display	19
10	210-7592 PCB	24
11	7592 PCB in Chassis	25
12	Rear View of Chassis with 7592 PCB Removed	26
13	Frontispiece (Assembly Part Number 177-3236DE)	35
14	External Covers Assembly	37
15	12" Monitor and 2236DE Workstation Chassis Assembly	41

LIST OF TABLES

<u>TABLE</u>	<u>TITLE</u>	<u>PAGE</u>
A	Baud Rate Settings	18
B	Power-Up Diagnostic Definitions	20

Service Newsletter

III.D.1

NO. 181

PERIPHERAL #55

December 28, 1979

2236DE INTERACTIVE TERMINAL

This Newsletter contains information necessary to unpack, install, and maintain the 2236DE Interactive Terminal. Also contained in this newsletter is a description of the 2236DE including electrical and physical specifications, and an explanation of the various features found on the 2236DE.



1. GENERAL DESCRIPTION

The 2236DE Interactive Terminal is a Z80-based intelligent CRT/-Workstation. It consists of a 12-inch (30.4 cm) diagonal measure CRT, a KEYTRONIC capacitive-type keyboard, a 12-Inch Monitor Electronics PCB (210-7456), and a Terminal PCB (210-7592) containing a Z80 micro-processor and the remaining workstation electronics. By locating most of the CRT electronics on one terminal board, production, installation, and maintenance procedures have been simplified.

NOTICE:

This document is the property of Wang Laboratories, Inc. Information contained herein is considered company proprietary information and its use is restricted solely to the purpose of assisting you in servicing Wang products. Reproduction of all or any part of this document is prohibited without the consent of Wang Laboratories.

WANG

LABORATORIES, INC.

ONE INDUSTRIAL AVENUE, LOWELL, MASSACHUSETTS 01851. TEL. (617) 459-5000. TWX 710 343-6769. TELEX 94-7421

PRINTED IN U.S.A.
REORDER NO.
729-0476

The 2236DE replaces the 2236D terminal on the VP/MVP product line. It offers several features not found on the 2236D Terminal. These features include character display attributes (highlighted displays, reverse video, etc.), alternate graphics set selection, box graphics, and screen dump. These features are explained in detail in Section 7 of this newsletter.

Power-up diagnostics are another feature of the 2236DE terminal. These diagnostic routines are run automatically whenever the terminal is turned on. Refer to Section 4 for further information.

The 2236D terminal will continue to be supported in the field; however, it will no longer be manufactured. It is not possible to upgrade a 2236D to a 2236DE.

1.1 CRT and Keyboard

The 2236DE CRT displays a full 128 character set, including upper and lower case keyboard characters, foreign language characters, special symbols, and underscore. Each character can be assigned one or more display attributes such as high- or low-intensity display, blinking, reverse video, or underscore. The CRT can also display box graphics separate from character sets.

The KEYTRONIC keyboard (See Figure 1) operates in either of two modes, selected by a toggle switch labeled "A/A" and "A/a". In the "A/A" mode, alphabetic characters are displayed as upper-case whether shifted or unshifted, and numeric keys produce symbols and special characters. In the "A/a" mode, the keyboard functions as a standard typewriter keyboard. All keys on the keyboard, except RESET and EDIT, repeat after an initial delay, if held down.

The RETURN and FN keys are located in the alphanumeric section of the keyboard. The RETURN key is used to signal the CPU that entry of a particular data-field is complete. The FN key is a special function key used with 2200VP/MVP CPU configurations.

The Program Control Keys (for program control and execution) are as follows:

RESET	stops program listing and execution immediately, clears CRT screen and returns control to the user.
HALT/STEP	causes program execution to halt at completion of current statement or to execute one line at a time.
CONTINUE	continues program execution after a STOP verb has been executed or the HALT/STEP key has been touched.
CLEAR	clears program text and variable areas.
LOAD	loads specified programs from storage into memory.
RUN	initiates execution of the program.

The numeric keypad is a standard 10-key pad. Digits can be entered by using the numeric keys in either the numeric or the alphanumeric section of the keyboard.

The 16 Special Function Keys, located at the top of the keyboard, can be used in conjunction with the SHIFT key to provide a total of 32 special functions. These keys are user-definable; their meanings can be changed under software control. They are also used by the 2200VP/MVP System Bootstrap during Master Initialization to load the BASIC-2 Interpreter and Operating System.

The EDIT key is used to enter and exit the Edit mode. When in Edit mode, the Special Function Keys operate as follows:

RECALL	Used to recall a program line or Immediate Mode statement from memory for edit.
←----	Moves cursor five spaces to the left.
←	Moves cursor a single space to the left.
----→	Moves cursor five spaces to the right.
→	Moves cursor a single space to the right.
INSERT	Expands a line for additional text and data entry by inserting a space character at current CRT cursor position.
DELETE	Deletes the character at current cursor position.

SPECIAL FUNCTION KEYS

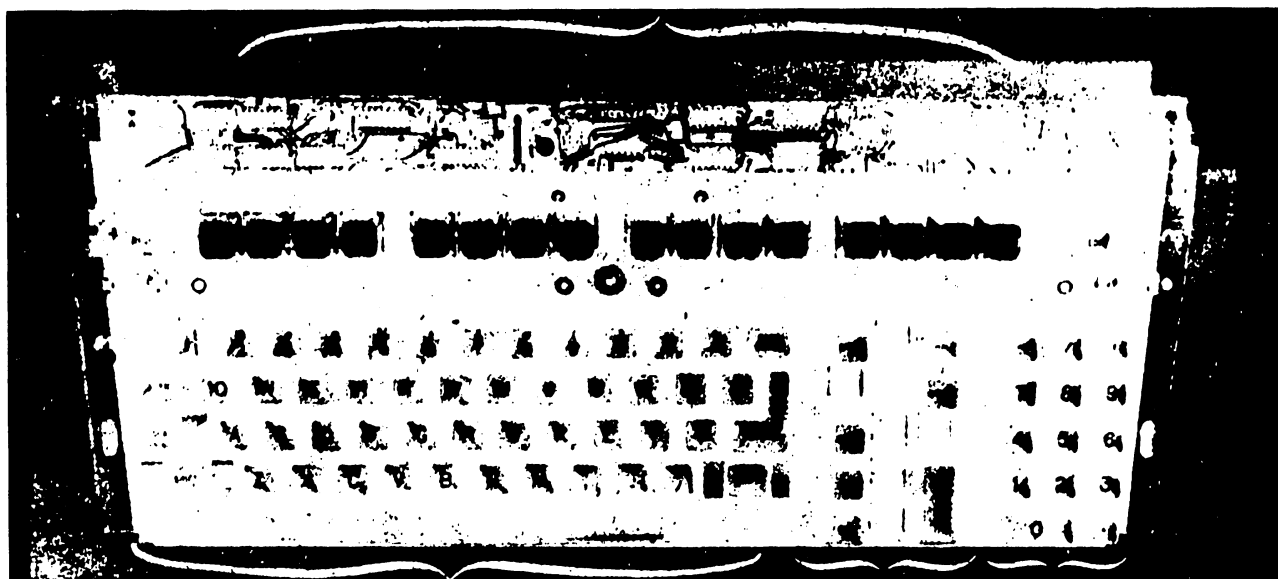

TYPEWRITER
KEYBOARD
(Alpha-Numeric Section)

PROGRAM
CONTROL KEYS

NUMERIC
KEY PAD

FIGURE 1 KEYTRONIC Keyboard

ERASE	Erases that portion of the line from the current CRT cursor position to the end of the line.
BEGIN	Moves cursor to the beginning of current text line.
END	Moves cursor to the end of current text line.
↑	Moves cursor up to the previous CRT line (current text must occupy more than one CRT line).
↓	Moves cursor down to the next line on the CRT (current text must occupy more than one CRT line).

1.2 Chassis Controls

There are four controls located on the terminal. The Brightness and Contrast controls are on the lower right side of the terminal front panel. These controls are used to adjust the video display.

Two controls, labeled Tone and Clicker, are located on the back of the terminal chassis. The Tone control is used to adjust the volume of the audio alarm, which is programmed to sound whenever an illegal operation is attempted. The Clicker control is used to adjust the volume of the clicker, a sound emitted when a key is stroked, indicating an acceptable keycode has been entered. (See Figure 8.)

1.3 Specifications

Following are the specifications for the 2236DE Terminal:

Physical Specifications:

Height	13.50 inches (34.3 cm)
Depth	20.50 inches (52 cm)
Width	19.75 inches (50.2 cm)
Weight	51 lbs (23.1 kg)

Electrical Specifications:

Power Requirements	115 or 230 \pm 10%
	50 or 60 Hz \pm .5 Hz
	40 Watts
Heat Output	140 BTU/hr

Electrical Specifications: (Cont'd)

Fusing	2A @ 115V/60 Hz
	1A @ 230V/50 Hz

Display Specifications:

Size	12 in. diagonal (30.4 cm)
Capacity	24 lines, 80 char. per line

Character Size:

Height	0.16 in. (0.41 cm)
Width	0.09 in. (0.23 cm)

Operating Environment:	50° to 90° F (10° to 32° C)
	20% to 80% relative humidity (noncondensing)

Transmission Rate:	Manually selectable at 300, 600, 1200, 2400, 4800, 9600, or 19,200 baud.
--------------------	--

2. SITE PREPARATION

The 2236DE is designed to operate in a normal office environment; radical changes in temperature or humidity can adversely affect the terminal (Operating Environment, Section 1.3). The 2236DE should be located in an environment similar to that of the central processor and a separate grounded outlet should be provided for it. Refer to the 2200MVP Maintenance Manual (03-0071-1), Section 2 for more details.

3. UNPACKING AND INSTALLATION

The 2236DE is shipped completely assembled. An 8 foot (2.4 m) AC power cord and one 25 foot (7.6 m) direct-connection (signal) cable is supplied with each terminal. Longer direct-connection cables can be ordered if desired. Refer to Section 8 for cable part numbers.

Before unpacking the terminal, check the packing slip to ensure that the proper equipment has been delivered. After checking the packing slip, inspect the shipping carton for damage (crushed corners, punctures, etc.). If the carton appears undamaged, carefully remove the terminal and inspect it for damage. If damage is discovered, file an appropriate claim promptly with the carrier involved and notify the WLI Distribution Center (Dept. #90), Quality Assurance Dept., Tewksbury, MA 01876. Inform them of the extent of damage and arrange for equipment replacement, if necessary.

After inspecting the terminal exterior, trace the outline of the exposed portion of the CRT screen with a grease pencil. This outline is used in Section 3.3 for video display adjustments. (See Figure 2.)

Remove the terminal cover as follows: (See Figure 3.)

- a. Remove the three Phillips screws located under the plastic strip on the keyboard and remove the keyboard plate.
- b. Remove the Phillips screws on the left and right side of the terminal cover.
- c. Lift the cover up and away from the terminal; take care not to hit or nick the CRT, or strain the Brightness/Contrast wires.
- d. Remove the Brightness and Contrast control wires from the clamp on the side of the cover. Lay the cover on its side next to the terminal. Do not unplug the Brightness and Contrast Molex connector from the cross-brace at the top of the CRT.
- e. Remove foam packing material from front of 210-7456 PCB.

Visually inspect the inside of the terminal for metal shavings, solder splashes, loose connections, and improperly seated PCBs. Do not replace the cover at this time.

3.1 Voltage and Frequency Selection

The 2236DE operates on either 115 or 230 VAC and at either 50 or 60 Hz. Before connecting the terminal to a power source, check the serial

DISTANCE BETWEEN PERIMETER LINE
AND RASTER SHOULD BE BETWEEN $\frac{1}{2}$ "
AND 1"

DRAW PERIMETER LINE AT START
OF INSTALLATION

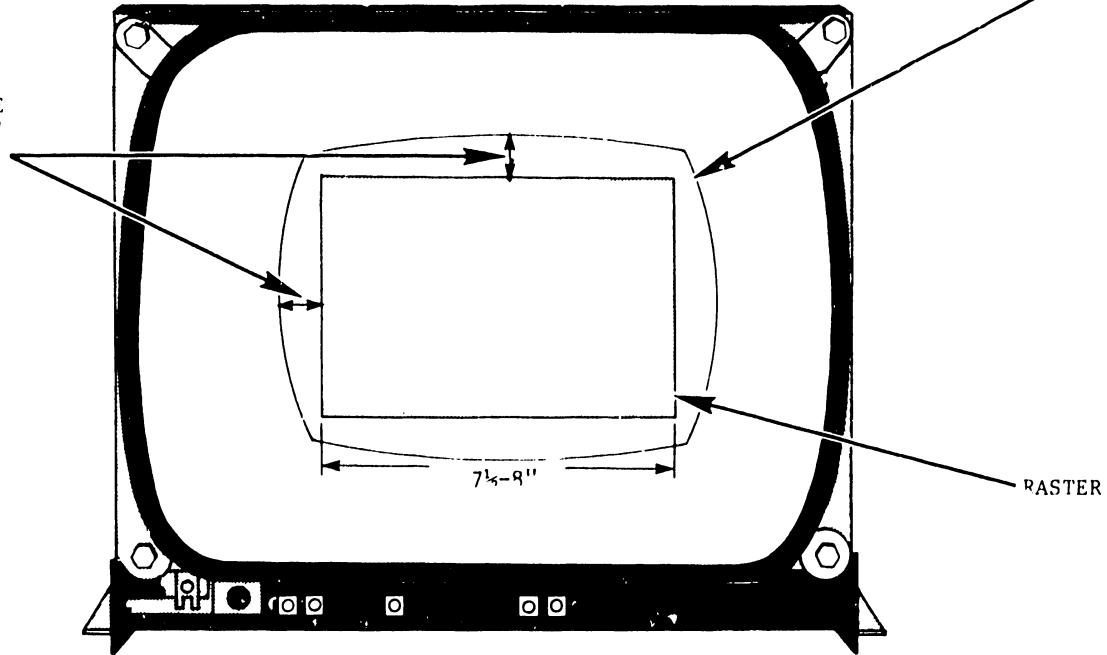

8

FIGURE 2 CRT Outline

tag attached to the terminal. Set the voltage-select switch on the lower right side of the CRT monitor to the appropriate position (115 or 230) and ensure that jumper J11 on the 210-7592 PCB is in position, if required. Install J11 if the terminal is to operate at 60 Hz, remove J11 if the terminal is to operate at 50 Hz. (See Figures 4 and 5.)

3.2 Voltage Checks and Adjustments

The power supply is located on the 210-7592 PCB. Five jumpers, labeled J14, J15, J16, J17, and J18, connect the power supply voltage to the logic circuits. Remove these five jumpers before performing the initial voltage checks and adjustments, which are performed as follows: (See Figures 5 and 6.)

****NOTE****

Use only one hand when working inside an electronic chassis that is powered-up. This avoids the risk of grounding oneself to the chassis with one hand while touching an electrical connection with the other, causing severe shock.

- a. Place the terminal in its permanent location.
- b. Ensure that the terminal ON/OFF switch on the rear of the chassis is in the OFF position. Plug in the AC power cord.
- c. Power-up the terminal.
- d. Connect the Common lead of a DVM to a \pm 0V location on the 210-7592 PCB. (Negative side of capacitor C19, for example.)
- e. Place the DVM probe against pin 1 of the J14 connector; a reading of +12 VDC \pm .12 should be obtained. Adjust R72 to obtain the proper reading if voltage is out of limits.
- f. Place the DVM probe against pin 1 of the J15 connector; a reading of +5 VDC \pm .05 should be obtained. Adjust R66 to obtain the proper reading if voltage is out of limits.
- g. Place the DVM probe against pin 2 of the J16 connector; a reading of +20 VDC \pm 3.0 should be obtained. This voltage is non-adjustable, replace PCB if voltage is out of limits.
- h. Place the DVM probe against pin 2 of the J17 connector; a reading of -5 VDC \pm .25 should be obtained. This voltage is



BRIGHTNESS AND
CONTRAST CONTROL
CLAMP

BRIGHTNESS
AND
CONTRAST

FIGURE 3 CRT and Cover

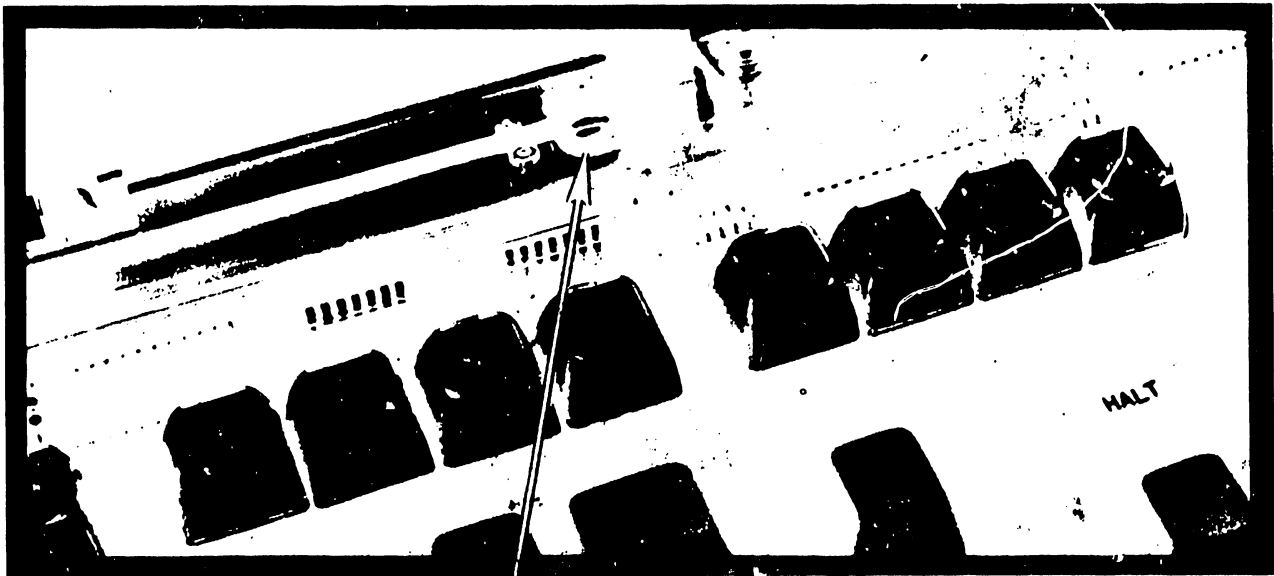

VOLTAGE SELECT SWITCH

← 115
230 →

FIGURE 4 Voltage Select Switch

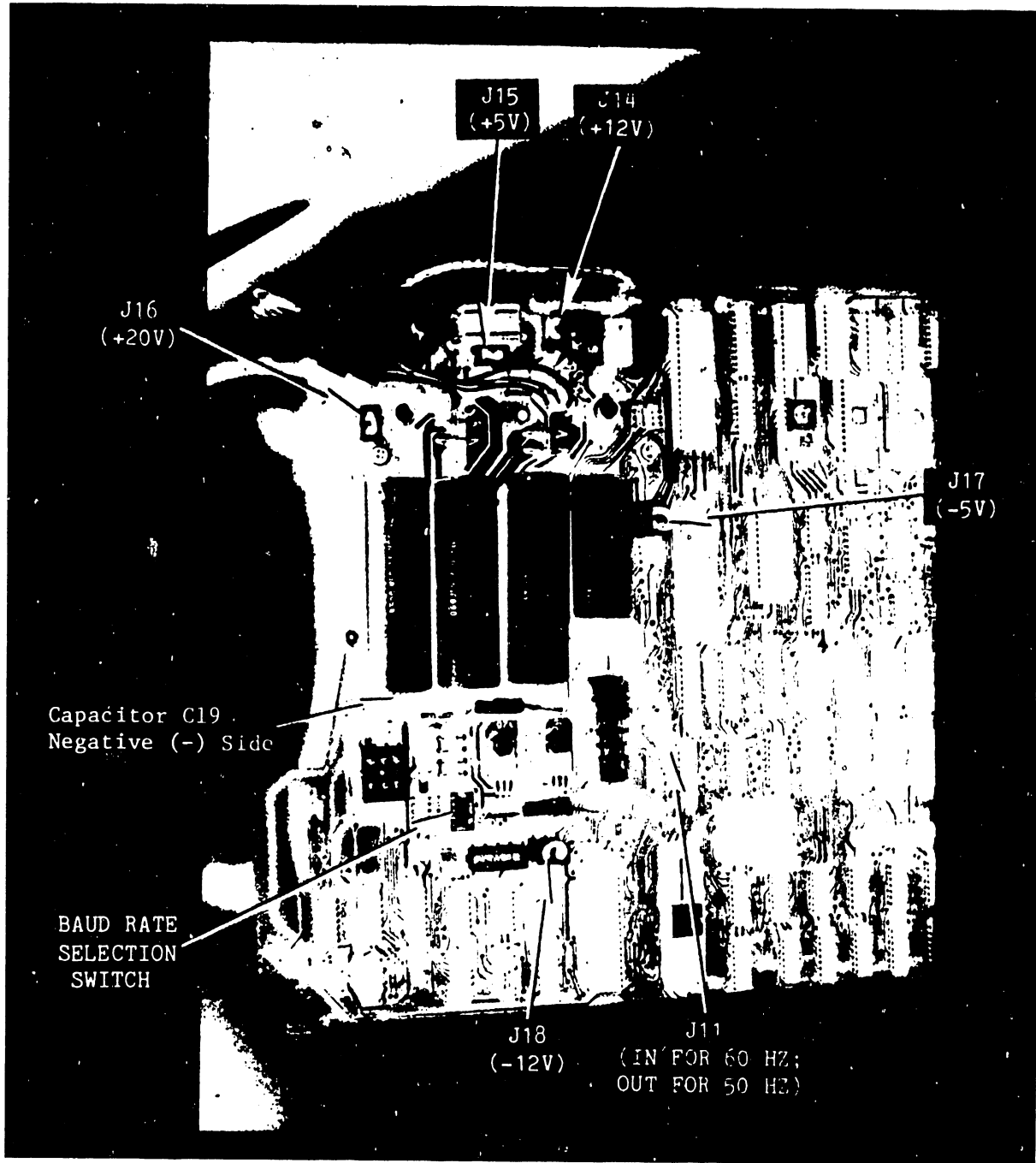

FIGURE 5 Jumper Locations (210-7592 PCB) and Baud Rate Selection Switch

R66
(+5V ADJUST)

R72
(+12V ADJUST)

L10
HEX LED
LOCATION

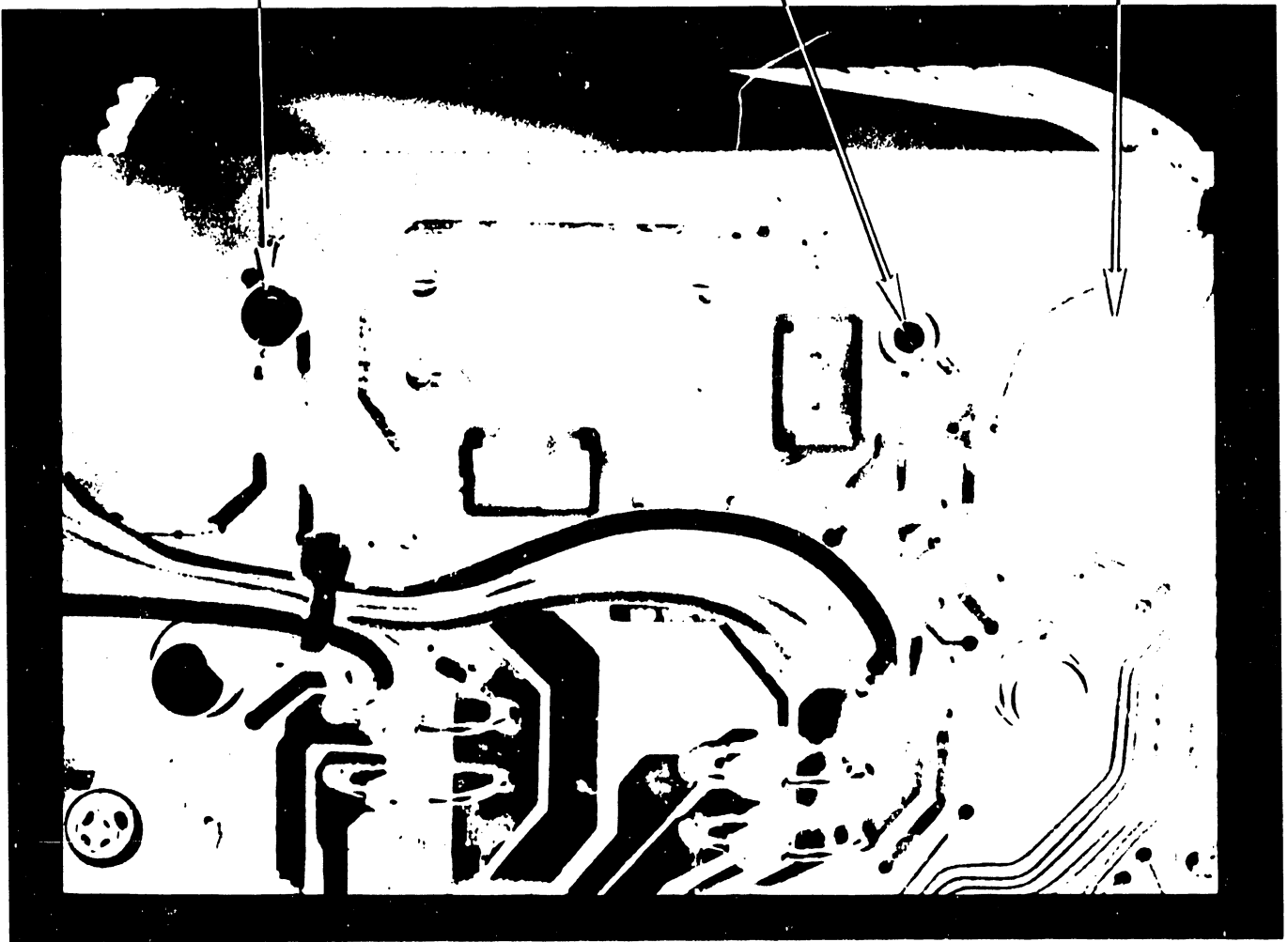

FIGURE 6 Close-up of R66 and R72

non-adjustable, replace PCB if voltage is out of limits.

- i. Place the DVM probe against pin 1 of the J18 connector; a reading of $-12 \text{ VDC} \pm .60$ should be obtained. This voltage is non-adjustable, replace PCB if voltage is out of limits.
- j. If voltages are within limits, power-down the terminal and reinstall the five jumpers.
- k. To check voltage under load conditions, power-up the terminal and recheck voltage readings according to the previous steps. Adjust voltages as necessary.

3.3 Video Display Adjustments

The following adjustments should not be attempted by anyone not familiar with CRT servicing procedures and precautions. Avoid prolonged close-range exposure to unshielded portions of the CRT to prevent injury from unnecessary exposure to X-ray radiation. Refer to Figures 2 and 7 when performing the following procedures.

Access to most display adjustment controls on the 7456 PCB is through the front of the terminal, using a non-conductive adjustment tool. Enter the following program on the 2236DE to display the letters HO over the entire CRT screen before performing the display adjustments:

```
1 FOR A = 1 TO 960
2 PRINT "HO";
3 NEXT A
```

- a. Adjust the brightness potentiometer (POT) located on the terminal cover until the video raster appears on the screen.
- b. If the character rows on the CRT are of unequal height, adjust the Vertical Linearity POT (R18) on the 210-7456 PCB.
- c. Adjust the Vertical Size POT (R24) on the 7456 PCB if a gap greater or less than $3/4" \pm 1/4"$ exists between the top edge of the raster and the pencil line (from Section 3) on the CRT face.
- d. Adjust the Width Coil (Z2) on the 7456 PCB if the horizontal size of the raster is not $7-3/4" \pm 1/4"$.

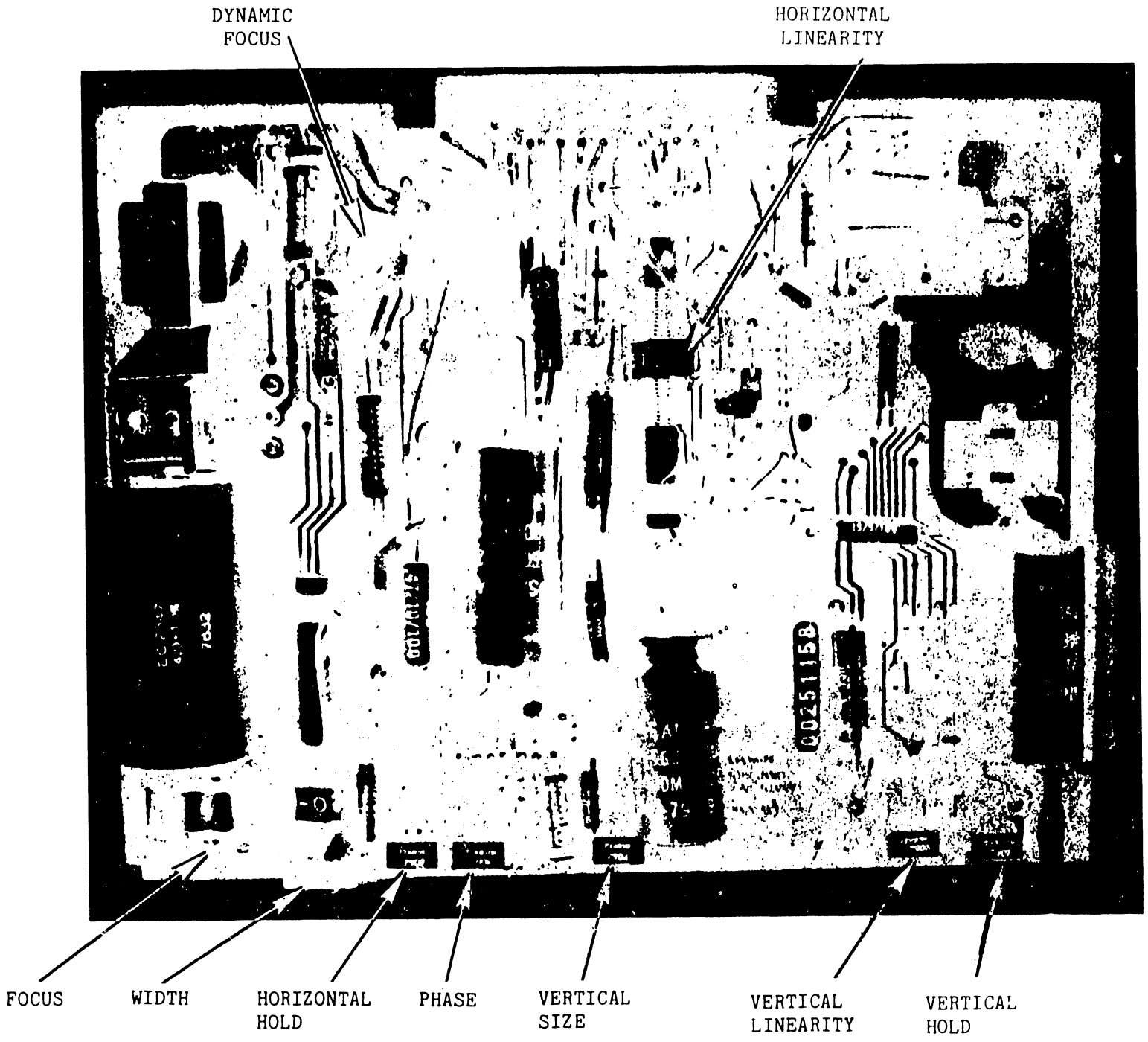

FIGURE 7 210-7456 PCB

- e. If the random character pattern is not horizontally aligned within the CRT display raster, adjust the Phase POT (R35) on the 7456 PCB to center the character set.
- f. Adjust the Focus POT, R28, on the 7456 PCB for best focus.

Once these adjustments have been made, power-down the terminal. Wash the grease pencil markings off the CRT face with a cloth dampened in a mild detergent solution. Perform Power-Up Diagnostics, as described in Section 4. If the diagnostics are successful, reassemble terminal and proceed as follows.

3.4 Terminal Interconnection

An RS-232-C and an AMP connector are located on the back of the terminal chassis. (See Figure 8.) As viewed from the rear of the terminal, the RS-232-C connector is on the right side, and connects the terminal to a CPU I/O controller (or a modem, for remote applications). The AMP connector is located beside the RS-232-C and connects the terminal directly to a printer. (Refer to Paragraph 7.4, Screen Dump.)

When used with a direct-connection cable, the 2236DE can be located up to 2,000 feet from a CPU. (Refer to Section 8, Cable Part Numbers.) This cable must be connected properly between the terminal and the controller. One end of the cable is labeled TER, the other is labeled MUX. Connect the end labeled TER to the RS-232-C connector. Do not connect the cable in reverse. The 2236DE can also be connected remotely to a CPU, via modems and telephone lines.

3.5 Terminal Controllers

The 2236DE is attached locally to a CPU by means of either of two devices: a 22C32 Triple Controller that connects the 2236DE to either a 2200VP or a 2200MVP system, or a 2236MXD Terminal Processor that connects the 2236DE to a 2200MVP system. By using a combination of two 2236MXDs and one 22C32, a total of nine terminals can be connected to an MVP System; only one 2236DE terminal can be connected to a VP system.

BAUD RATE SELECTION
(PLUG REMOVED)

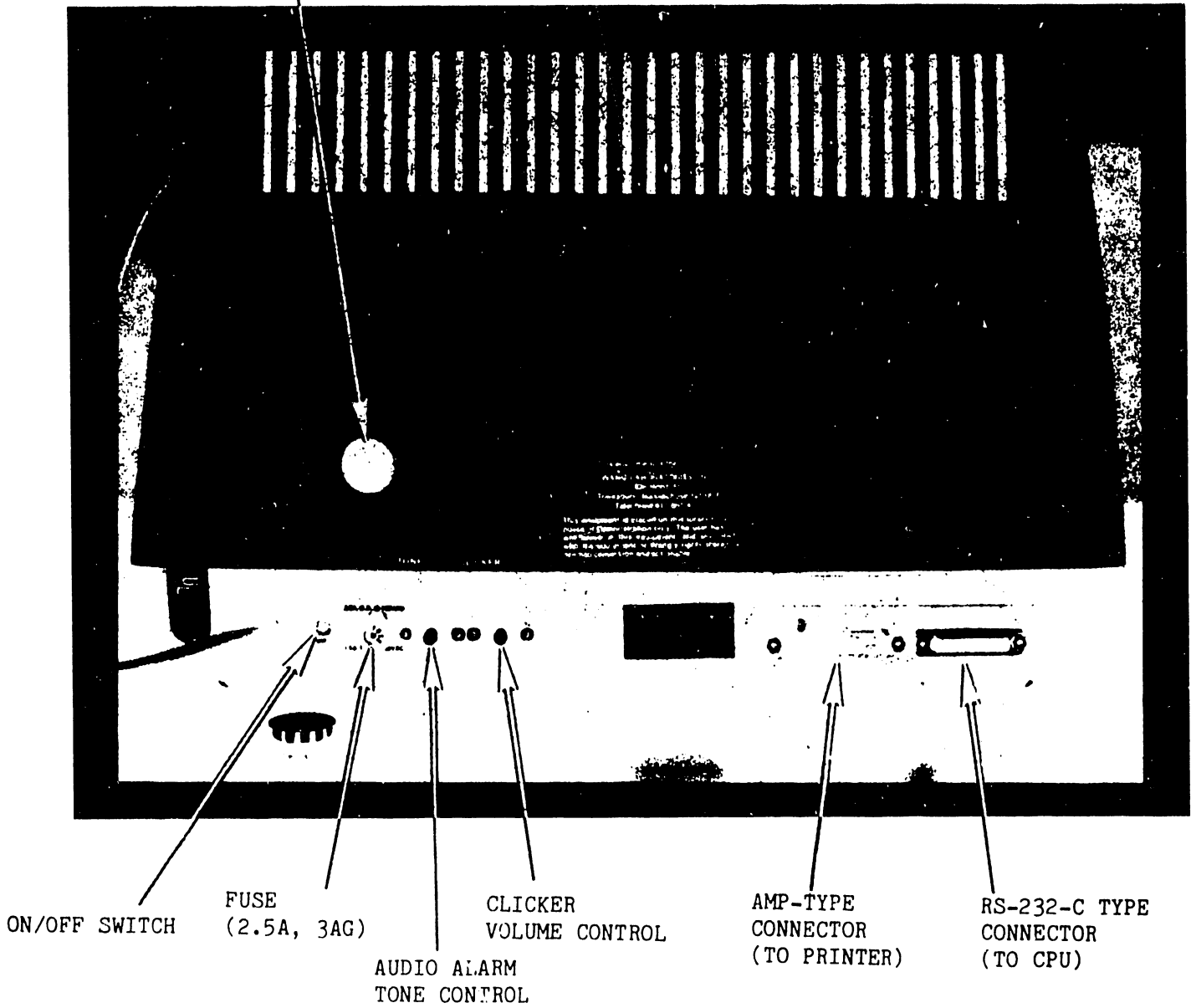

FIGURE 8 Rear of Terminal

The 22C32 and 2236MXD handle I/O operations between the terminal and CPU and act as buffers for data transmitted to/from the terminal. Communications between the terminal and the CPU by means of either a 2236MXD or 22C32 is asynchronous, full-duplex. The 2236MXD offers selectable line speeds ranging from 300 to 19.2K Baud; the 22C32 Triple Controller has a fixed communication rate of 19.2K Baud.

There are no modems capable of handling a 19.2K transmission rate, at this time. Because of this, the 22C32 Triple Controller, with its fixed 19.2K Baud rate, cannot support remote workstation applications. A 2236MXD controller must be used because of its selectable line speeds.

3.6 Controller Switch Settings

Refer to Paragraphs 3.3.2 through 3.4.2 of the 2200MVP Maintenance Manual (03-0071-1) for information concerning device address and baud rate settings for the 2236MXD. PROMs used on the 2236MXD must be R5 or above, the 210-7290-1 PCB must be at Rev. 1 or greater, and the 210-7291-1 PCB must be at Rev. 2 or greater in order to use a 2236DE terminal with a 2236MXD controller.

Because the 22C32 Triple Controller has a fixed baud rate of 19.2K, only device address switches, located on the lower right side of the 210-7515 PCB, are set in the controller. There are three switch banks on the 7515 PCB, the bottom right-most bank is used to set the terminal device address. Set these switches as follows:

<u>Number of</u> <u>Terminals</u>	<u>Switch Settings*</u>					<u>Device Address</u>
	<u>Sw1</u>	<u>Sw2</u>	<u>Sw3</u>	<u>Sw4</u>	<u>Sw5</u>	
One	1	0	0	0	0	00 ₁₆
Five**	1	0	0	1	0	40 ₁₆
Nine***	1	0	0	0	1	80 ₁₆

* 0 = OFF; 1 = ON. Sw1 is the Terminal Enable, it is always set to 1; Sw2 - Sw5 are the Terminal Device Address Switches.

** One 2236MXD; One 22C32 (MVP System only)

*** Two 2236MXDs; One 22C32 (MVP System only)

3.7 Baud Rate Selection

The baud rate selection switches for the 2236DE are located on the 210-7592 PCB. Access these switches by removing the large plug on the back of the terminal. (See Figures 5 and 8.) Switch One must be ON and Switch Two must be OFF; these two switches determine the number of data bits and type of parity used. Ensure that the baud rate switch settings at the terminal are the same as those at the controller or modem. Set the baud rate switches according to Table A.

Table A: Baud Rate Settings

<u>Baud Rate</u>	<u>Switch 1</u>	<u>Switch 2</u>	<u>Switch 3</u>	<u>Switch 4</u>	<u>Switch 5</u>
<u>300</u>	<u>ON</u>	<u>OFF</u>	<u>ON</u>	<u>ON</u>	<u>ON</u>
<u>600</u>	<u>ON</u>	<u>OFF</u>	<u>OFF</u>	<u>ON</u>	<u>ON</u>
<u>1200</u>	<u>ON</u>	<u>OFF</u>	<u>ON</u>	<u>OFF</u>	<u>ON</u>
<u>2400</u>	<u>ON</u>	<u>OFF</u>	<u>OFF</u>	<u>OFF</u>	<u>ON</u>
<u>4800</u>	<u>ON</u>	<u>OFF</u>	<u>ON</u>	<u>ON</u>	<u>OFF</u>
<u>9600</u>	<u>ON</u>	<u>OFF</u>	<u>OFF</u>	<u>ON</u>	<u>OFF</u>
<u>19,200</u>	<u>ON</u>	<u>OFF</u>	<u>ON</u>	<u>OFF</u>	<u>OFF</u>

4. POWER-UP DIAGNOSTICS

Whenever the 2236DE terminal is powered-up, diagnostic routines resident in the Z80 microcode are performed. If the diagnostics pass, the power-up message is displayed (see Figure 9) and control passes to the main microcode. The power-up message is displayed for three seconds and is cleared when the first character is received from the CPU. However, if the CPU is powered-up before the terminal CRT is sufficiently warmed-up, the terminal power-up message may not appear. If this occurs, power-down then immediately power-up the terminal.

If a failure is detected by the diagnostics, an audio alarm is activated and control is not passed to the main microcode. A HEX LED (WLI #340-0015) installed at location L10 on the 7592 PCB (see Figure 6) will display the failing diagnostic phase. Table B lists the diagnostic displays and possible causes of failure.

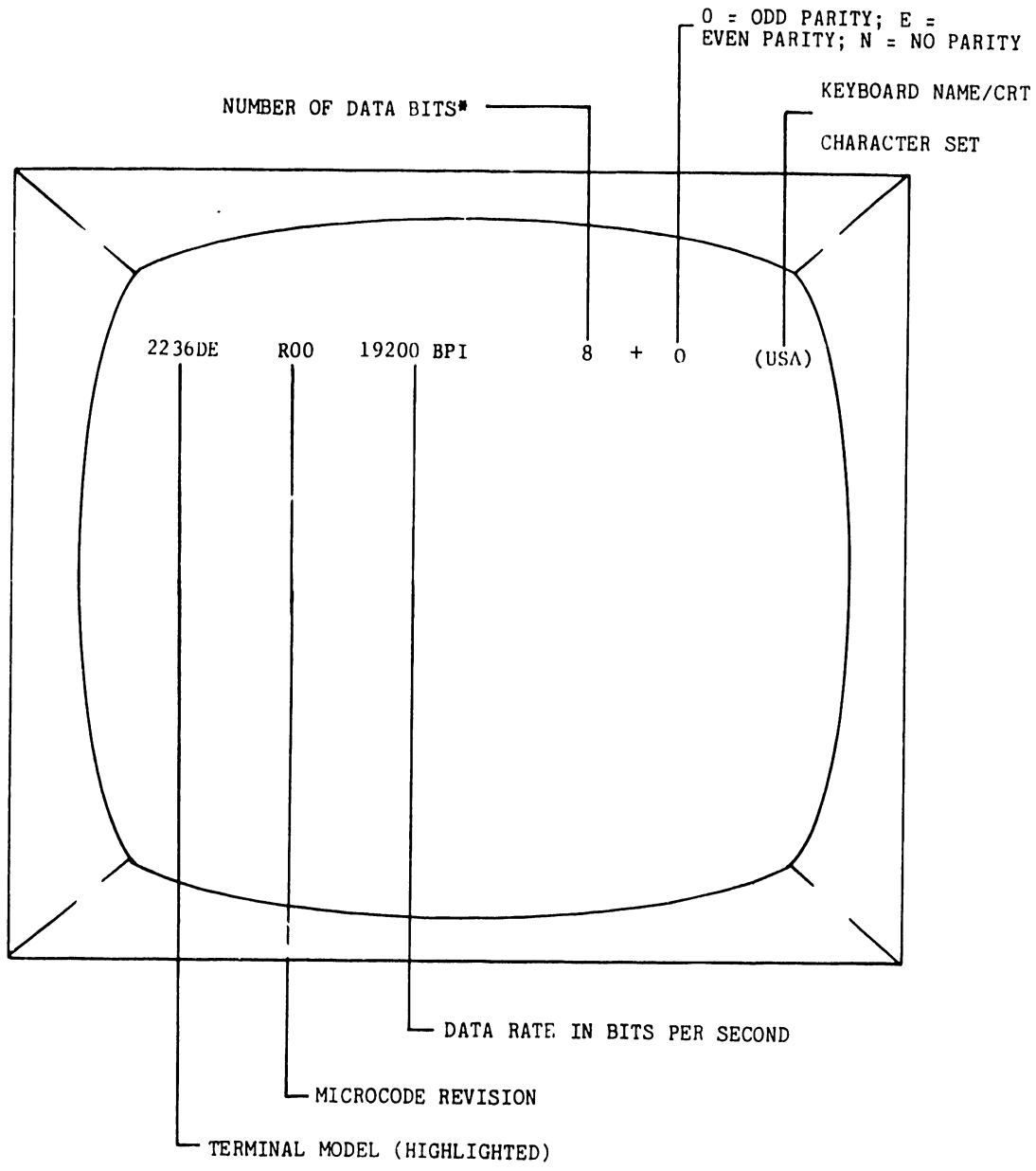

Figure 9: Terminal Display

* If the # symbol is displayed, either the baud rate switches are incorrect or a problem exists in the terminal. If "???" is displayed, the baud rate switches are in an illegal setting. In this state the baud rate is undefined.

Table B: Power-Up Diagnostic Definitions

HEX LED DISPLAY	DISPLAY MEANING	TROUBLE LOCATIONS
0000	Z80 or PROM malfunction, or address decoding logic malfunction.	L2, L8, L9, L16, L17, L18, L19
0001	Z80 Reset and Conditional Jump Test	L2, L8, L9, L16, L17, L18, L19, L44
0010	Z80 Register and Processor Test	L9, L2, L44
0011	Memory Select Test	L8, L9, L19
0100	Data Bus Test	L9, L44, L51
0101	Address Bus Test	L8, L9, L19
0110	RAM Test	L4, L5
0111	RAM Test	L4, L5
1000	Not Used	
1001	PROM Test	L16, L17, L18, L56
1010	Keyboard Table PROMs Test	L16, L17, L18, L56
1011	Vertical Retrace Interrupt Test	L52, L79, L96

At power-up, the hardware blanks the Hex display. If either the Z80 (L9) and PROMs (L16, 17, 18), or the address decoding (L8, 19) logic are malfunctioning, the display could stay blanked. If any test fails in a predicted manner, the Hex display remains at the value of the failed test. After all tests are completed, the diagnostic loads a "0" into the display and passes control to the main microcode.

5. PREVENTIVE MAINTENANCE

Preventive maintenance on the 2236DE is scheduled for every six months. It consists of inspecting the terminal for worn parts, adjusting the terminal controls as needed, general cleaning of the terminal, and updating the terminal with the appropriate ECNs.

Routine maintenance consists of cleaning the terminal cover, keyboard, and CRT face with a mild detergent solution when necessary.

6. MAJOR ASSEMBLY REMOVAL AND REPLACEMENT

This section discusses removal and replacement procedures for several major workstation assemblies. (See Figures 10, 11 and 12.) Before removing the following assemblies, ensure that the power switch is OFF and the AC power cord is unplugged. Remove the terminal cover as described in Section 3.

6.1 CRT Anode Discharge Procedure

Even with power removed, the terminal cathode ray tube can hold a charge of several thousand volts. To eliminate the risk of accidental CRT discharge, which can result in serious injury, discharge the CRT anode as follows: (See Figure 12)

- a) Attach* one end of a length of insulated wire to the metal shaft of a plastic-handled, heavy-duty screwdriver.
- b) Attach* the other end of the wire to CHASSIS GROUND.
- c) Using a non-conductive tool such as a plastic alignment tool, carefully raise the edge of the rubber anode cap high enough to insert the screwdriver.
- d) Taking care not to touch the metal shaft of the screwdriver or any metal part of the terminal, discharge the CRT anode by touching the anode clip with the grounded screwdriver.
- e) After discharging the CRT, remove the grounding wire and reseal the rubber anode cap.

6.2 Terminal Electronics PCB Removal

Remove the Terminal Electronics PCB (210-7592) as follows:
(See Figures 10, 11, and 12.)

- a) Unplug all Molex connectors on the PCB.

* Attach wire by means of alligator clips. If no clips are available, strip 3/4" of insulation from each end of the wire. Tightly wrap one end around the screwdriver shaft, secure the other end to CHASSIS GROUND, NOT LOGIC GROUND.

- b) Unplug the keyboard, printer, and CPU ribbon cables.
- c) Remove the four Phillips-head screws holding the PCB to the CRT chassis support rods.
- d) Lift the board up and out of the terminal.

To replace or reinstall the Terminal Electronics PCB, reverse the above procedure.

6.3 CRT Chassis Assembly Removal

Remove the CRT Chassis Assembly (270-0372) as follows: (See Figure 12)

****NOTE****

In a 2236DE Terminal, replace a defective CRT chassis with a Wang CRT Chassis Assembly only.

- a) Unplug all Molex connectors on the 210-7592 PCB.
- b) Unplug the keyboard, printer, and CPU ribbon cables from the 210-7592 PCB.
- c) Unplug the Brightness/Contrast Molex connector from the cross-brace at the top of the CRT chassis.
- d) Remove the four Phillips-head screws holding the 7592 PCB support rods to the CRT chassis.
- e) Lift the 7592 PCB, still attached to the support rods, up and out of the terminal.
- f) Remove the four screws and star washers securing the CRT chassis to the terminal. The Monitor Electronics PCB (7456) is part of this chassis.
- g) Carefully lift the CRT Chassis Assembly up and out of the terminal.
- h) Reverse the above procedure to install a new assembly.
- i) Adjust Z1 on the 7456 PCB to achieve an 80X24 character display on the CRT.
- j) Perform the video display adjustments found in Section 3.3.

6.4 Monitor Electronics PCB Removal

Remove the Monitor Electronics PCB (7456) by grasping the front of the PCB and pulling with a slow steady pressure, moving the PCB gently from side-to-side. Insert the Monitor PCB by reversing this procedure.

6.5 KEYTRONICS Keyboard Assembly Removal

Remove the KEYTRONICS Keyboard Assembly (725-2618) as follows:

- a) Remove the four Phillips-head screws securing the keyboard to the chassis. Check that all four washers located between the keyboard and the chassis are accounted for.
- b) Unplug the keyboard ribbon cable from the keyboard PCB.
- c) Remove screw connecting keyboard ground strap to terminal chassis.
- d) Lift the keyboard up and away from the chassis.

To replace or reinstall the keyboard, reverse the above procedure.

6.6 Power Transformer Removal

Remove the Power Transformer (410-0116) from the chassis as follows:

- a) Unplug the Molex connector joining the transformer to the 7592 PCB.
- b) Remove the four Phillips-head screws and washers securing the transformer to the chassis.
- c) Lift the transformer up and out of the chassis.

To replace or reinstall the transformer, reverse the above procedure.

CRT
CONNECTOR

(J3)
TRANSFORMER
CONNECTOR

BRIGHTNESS
AND CONTRAST
CONTROL
CONNECTORS

(J5)
CLICKER & TONE
CONTROL CONNECTOR

KEYBOARD
TERMINAL
(J12)

PRINTER TERMINAL
(TO AMP-TYPE CONNECTOR)
(J1)

CPU TERMINAL
(TO RS-232-C CONNECTOR)
(J2)

SPEAKER
CONNECTOR
(J4)

FIGURE 10 210-7592 PCB

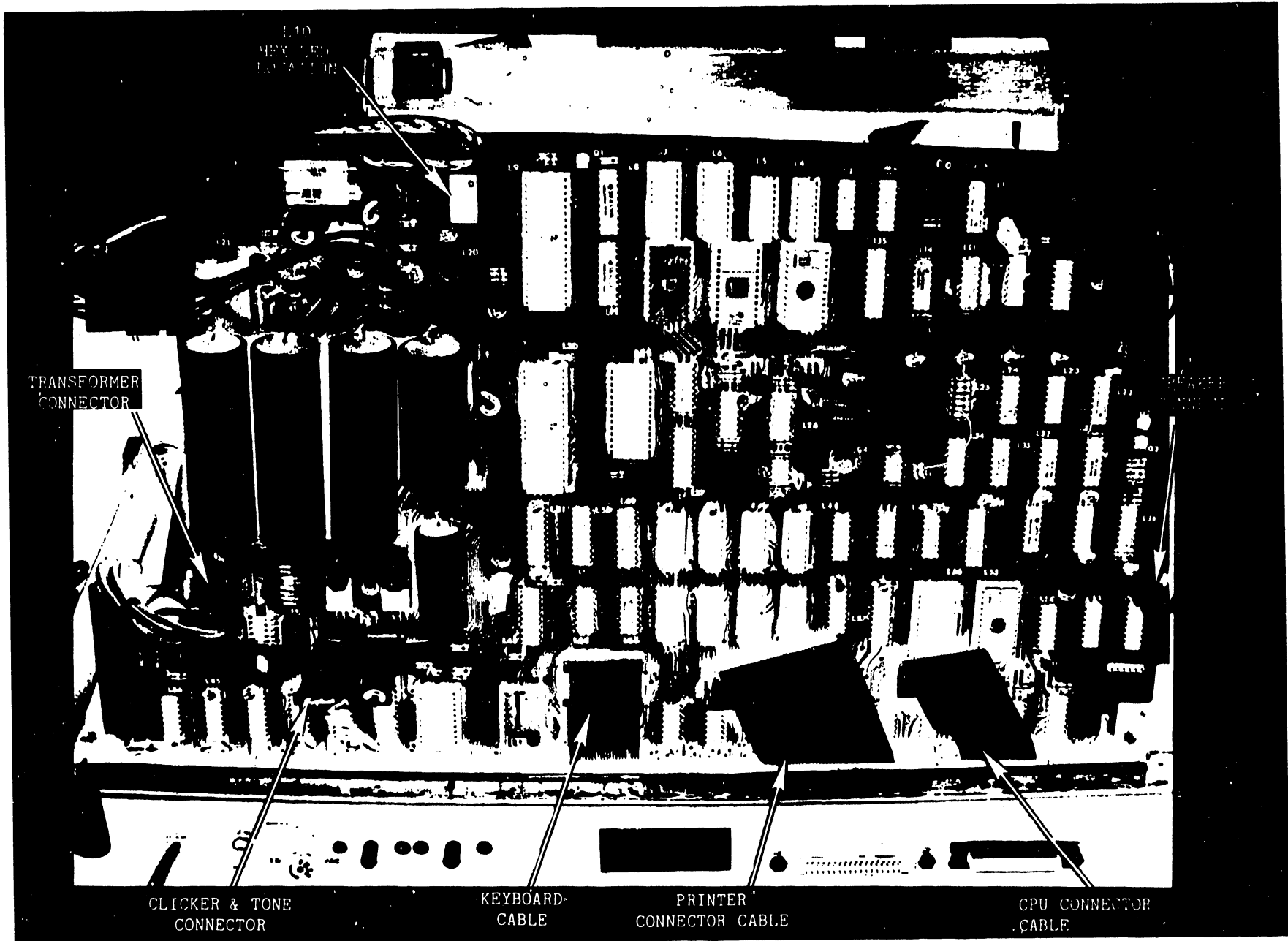

FIGURE 11 7592 PCB in Chassis

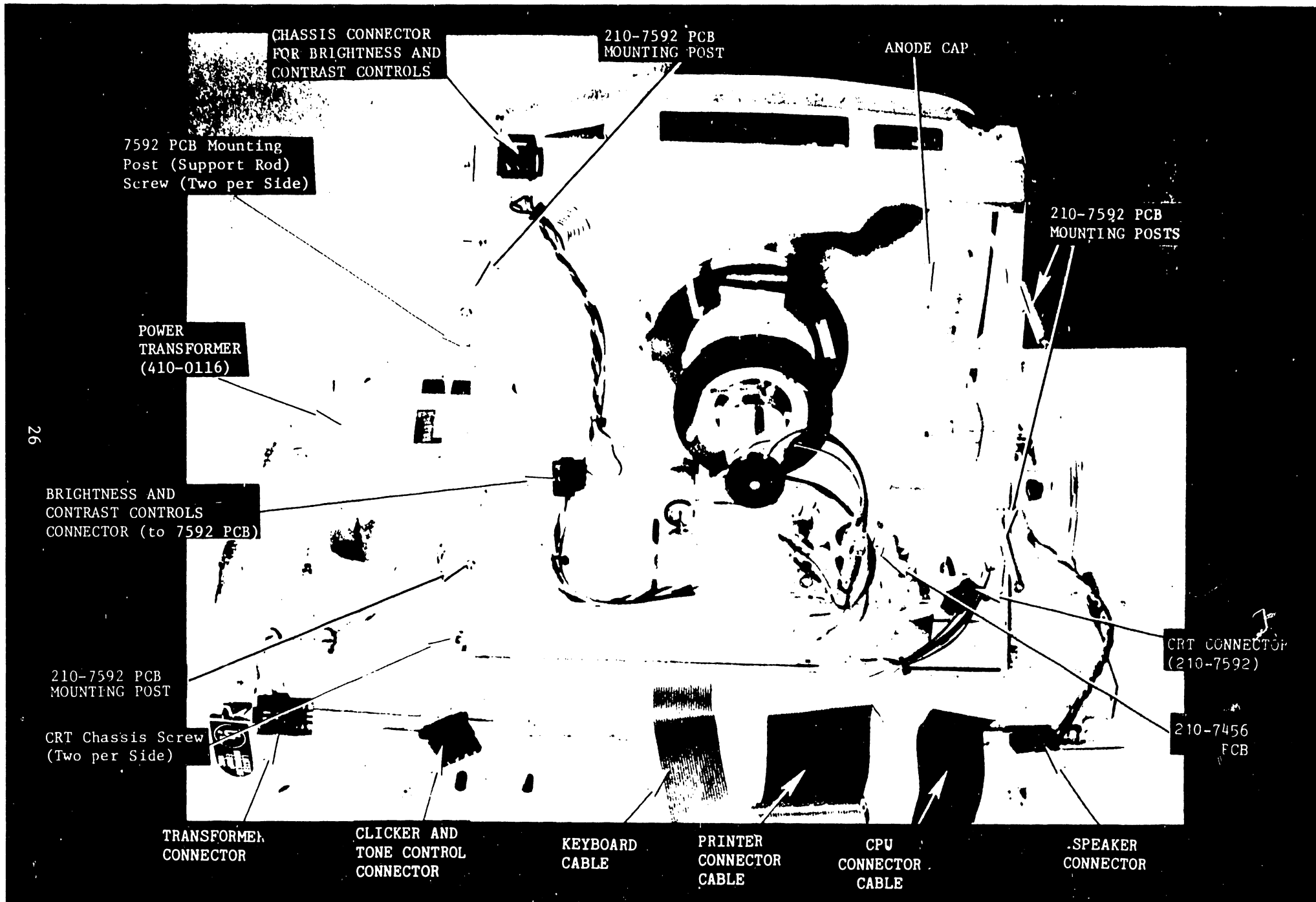

FIGURE 12 Rearview of Chassis with 7592 PCB Removed

7. STANDARD FEATURES

This section explains four standard features found on the 2236DE Terminal. These features are: Character Display Attributes, Alternate Graphics Set Selection, Box Graphics, and Screen Dump.

7.1 Character Display Attributes

Character display attributes can be selected for any character on the screen. They allow the user to highlight certain information. These attributes are as follows:

- a. Bright -- characters are displayed in high intensity.
- b. Blink -- characters appear to blink.
- c. Reverse Video -- background is white, characters are black.
- d. Underscore -- characters are displayed with an underscore.

The display attribute to be used is selected by sending a command of the following form to the CRT:

```
HEX(02 04 xx yy OE)      (Activates attribute)
HEX(02 04 xx yy OF)      (Terminates attribute)
```

```
where xx = 00 if not bright, no blink
           02 if bright
           04 if blink
           0B if bright, blink (not supported by 2236DE)
```

```
yy = 00 if not reverse video, no underscore
      02 if reverse video
      04 if underscore
      0B if reverse video, underscore
```

The selected display attribute is activated by HEX(OE) as in activating expanded print on certain Wang printers. If the selection sequence ends with HEX(OE), the selected display attribute begins immediately and remains in effect until the HEX(OF) command is given. Thus, it is possible to apply these display attributes to a portion of

a line or to several lines. Termination of the display attribute is accomplished by either carriage return (HEX(0D)) or HEX(0F).

The following is a summary of rules governing character attributes:

- a. HEX(02 04 xx yy 0F) selects but does not activate the specified display attribute.
- b. HEX(02 04 xx yy 0E) selects and activates the specified display attribute. HEX(0D) does not turn off the attribute.
- c. HEX(0F) is used to terminate the display attribute.
- d. CLEAR, RESET, and Screen Clear (HEX(03)) select normal display.
- e. HEX(0E) reactivates the selected display attribute. The attribute remains in effect until the occurrence of a HEX(0F) or a HEX(0D) (carriage return).
- f. Alternate attributes apply only to codes equal to HEX(10). Carriage return, line feed, non-destructive space, etc., preserve their meanings. PRINT AT() can be used to position the cursor. The third argument of PRINT AT(), used to blank sections of the screen, will work differently depending upon which attribute is currently selected.
- g. HEX(20) is a destructive space. PRINT TAB() and zoned format PRINT statements (PRINT,) position the cursor with HEX(20)s, their effects vary with the currently active display attribute.
- h. The operating system considers all codes HEX(00)-HEX(0F) to occupy no space on output medium. So alternate attribute selection sequences can be included in programs without concern that the operating system may create automatic carriage returns at undesirable times.
- i. The USA Model 2236DE uses Normal/Underline as the default selection for codes HEX(80)-HEX(FF).

7.2 Alternate Graphics Set Selection

This feature allows the user to redefine the meaning of characters HEX(80) to HEX(FF). Use of the alternate character set provides up to 128 additional characters. The upper characters in the alternate character set are defined as graphics characters. When displayed, graphics characters are expanded to fill the entire character

position, enabling continuous lines (bars) to be displayed. The graphics character set consists of characters representing all combinations of sixths of a character space. The following sequence is used for alternate graphics set selection:

HEX(02 02 xx 0F)

where: xx = 00 if codes HEX(90) to HEX(FF) are used to underscore the normal characters HEX(10) to HEX(7F).
= 02 if the alternate character set is to be used for codes HEX(80) to HEX(FF).

The rules governing character set selection are as follows:

- a. HEX(02 02 00 0F) selects the upper character set to be the normal characters, HEX(10) to HEX(7F) with underline.
- b. HEX(02 02 02 0F) selects the alternate character set for codes HEX(80) to HEX(FF), including character graphics symbols.
- c. Power On, CLEAR, and RESET select the default mode for codes HEX(80) to HEX(FF).
- d. The standard 2236DE uses normal character/underline as the default selection for codes HEX(80) to HEX(FF).

7.3 Box Graphics

This feature allows the user to display continuous horizontal and vertical lines, enabling information to be separated by lines or boxes. The horizontal line unit is displayed between character lines. It is the length of a character space and is positioned from the middle of one character space to the middle of the next. Vertical lines are drawn through the middle of a character space, coexisting with the character at that location. The vertical line unit is the height of a character space.

The Box Graphics feature allows the user to consider the CRT as having two separate displays (a box graphics display and a character display) located on one screen. In normal character mode, characters

and their attributes are modified while box graphics remain intact (Screen Clear clears both characters and box graphics). Characters and their attributes are undisturbed during a box graphics sequence. Because character mode and box graphic mode are independent of each other, it is easy to update portions of either display.

The BASIC-2 command "BOX (height, width)" allows users to implement the box feature. The first expression specifies the height of the box, the second specifies the width. The sign of the argument determines whether lines are drawn or erased: lines are drawn if the sign is positive, lines are erased if the sign is negative. If the box height is zero, a horizontal line is drawn or erased. A width of zero causes a vertical line to be drawn or erased. The box function positions the box so that the upper left hand corner is at the current cursor position. The CRT cursor does not move while a box is drawn.

The third argument of PRINT AT() is useful for clearing portions of the display. Though slower than screen clear, the statement "PRINT AT(0,0,)" is useful for clearing the characters from the screen without disturbing the box graphics.

7.4 Screen Dump

This feature allows the user to obtain a hard-copy record of the CRT display through a local printer. The local printer must be directly connected to the 2236DE through the printer connector located on the back of the terminal (printer address = 204_{16}).

Screen Dump is activated by depressing the EDIT key for two seconds. The Screen Dump sequence is as follows:

- a. EDIT key is depressed and held (immediate click).
- b. After two seconds, a second click is sounded to indicate that the screen dump has been activated. Normal edit functions are invoked if key is released before second click.
- c. CRT and Printer buffers are no longer serviced. (Present print job interrupted)

- d. Carriage Return is transmitted to printer.
- e. "Top-of-Form" command is transmitted to printer.
- f. The screen contents are printed. (Non-printable characters appear as "#")
- g. "Top-of-Form" command is transmitted to printer.
- h. Normal processing resumes.

The keyboard remains active during a screen dump. Depressing any key causes the screen dump to cease and normal processing to resume. If a user is printing through the terminal printer, the screen dump will be inserted in the printout. Even though screen dumps cause a page eject before and after the dump, minor problems could occur depending on the type of document being printed.

8. CABLE PART NUMBERS

Direct-connection cables (non-extendable) are available in 100 foot (30.5m) increments for distances up to 2000 feet (609.6 m). Modem cables are available in 12 foot (3.7 m), 25 foot (7.6 m), and 50 foot (15.2 m) lengths; however, combined cable distance from Wang equipment to a modem should not exceed a maximum of 50 feet (15.1 m) according to EIA standards. Cable numbers and lengths are as follows:

<u>Length</u>	<u>Part No.</u>
25 feet	220-2236-25
50 feet	220-2236-50
100 feet	220-2236-1
200 feet	220-2236-2
300 feet	220-2236-3
400 feet	220-2236-4
500 feet	220-2236-5
600 feet	220-2236-6
700 feet	220-2236-7
800 feet	220-2236-8
900 feet	220-2236-9
1000 feet	220-2236-10
1250 feet	220-2236-11
1500 feet	220-2236-12
1750 feet	220-2236-13
2000 feet	220-2236-14

THIS PAGE IS INTENTIONALLY LEFT BLANK

SECTION 9

ILLUSTRATED PARTS BREAKDOWN

9.1 SCOPE

The following Illustrated Parts Breakdowns (IPB) provide reference to assemblies that are identified for maintenance procedures. IPB's included in this manual are:

- Figure 13. Frontispiece (Assembly Part Number 177-3236DE)
- Figure 14. External Covers Assembly
- Figure 15. 12" Monitor and 2236DE Workstation Chassis Assembly

THIS PAGE IS INTENTIONALLY LEFT BLANK

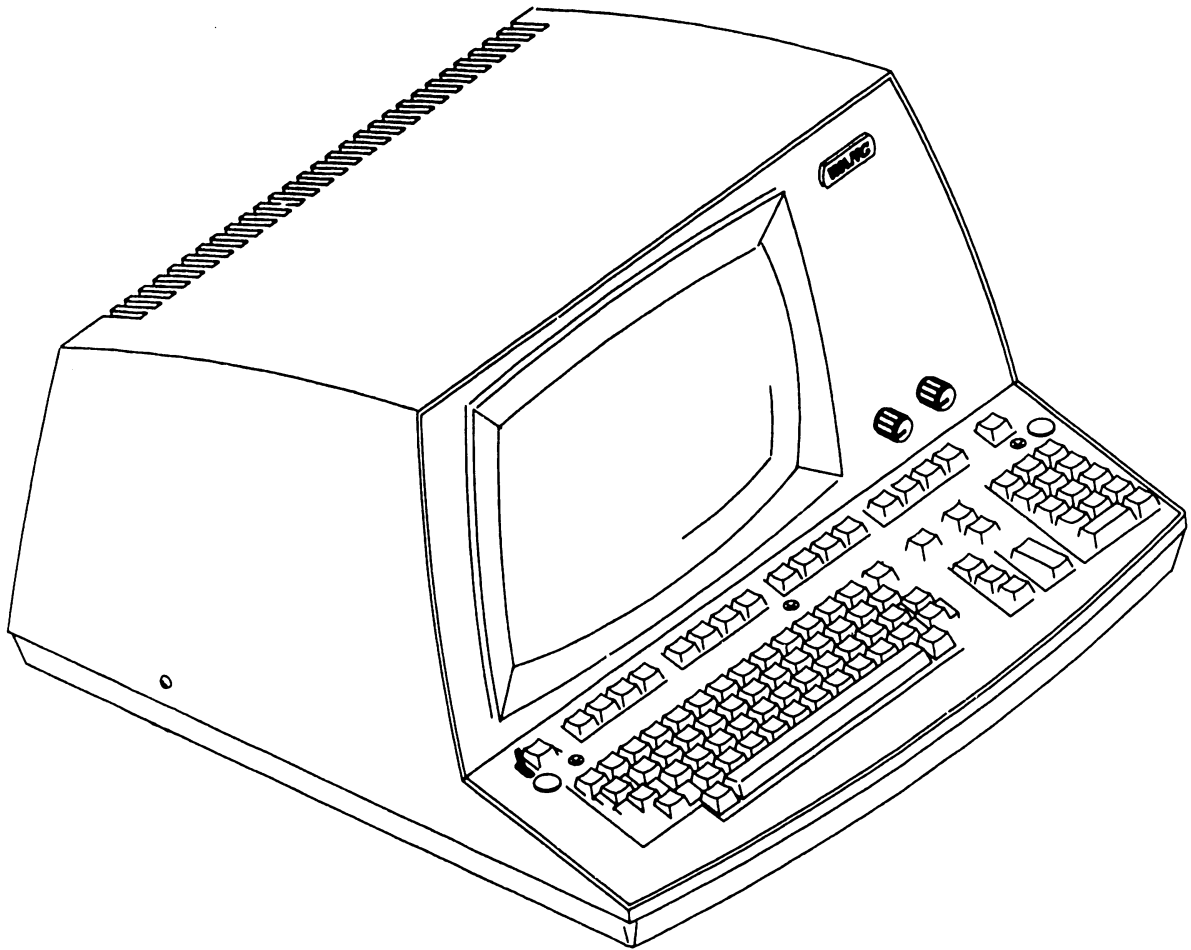

FIGURE 13 FRONTISPIECE (ASSEMBLY PART NO. 177-3236DE)

EXTERNAL COVERS ASSEMBLY

ITEM NO.	PART NO.	DESCRIPTION
1	449-0289	COVER, MACH (OPEN VENTS)
2	615-0398	PROGRAM STRIP
3	452-1068	PLATE FINISHING WLDMENT
4	449-0459	BEZEL, 12" CRT
5	449-0548	PLATE LOGO, WORKSTATION
6	655-0157	KNOB, ALCO
7	652-0036	3/8"-32, NUT
8	653-0022	LOCK WASHER
9	220-0160	CABLE ASSEMBLY, BRIGHTNESS POT
10	725-2618	KEYBD DW STANDARD
11	279-1026	BASE ASSEMBLY
12	650-4105	10-32x11/8 TRUSS HD PHL

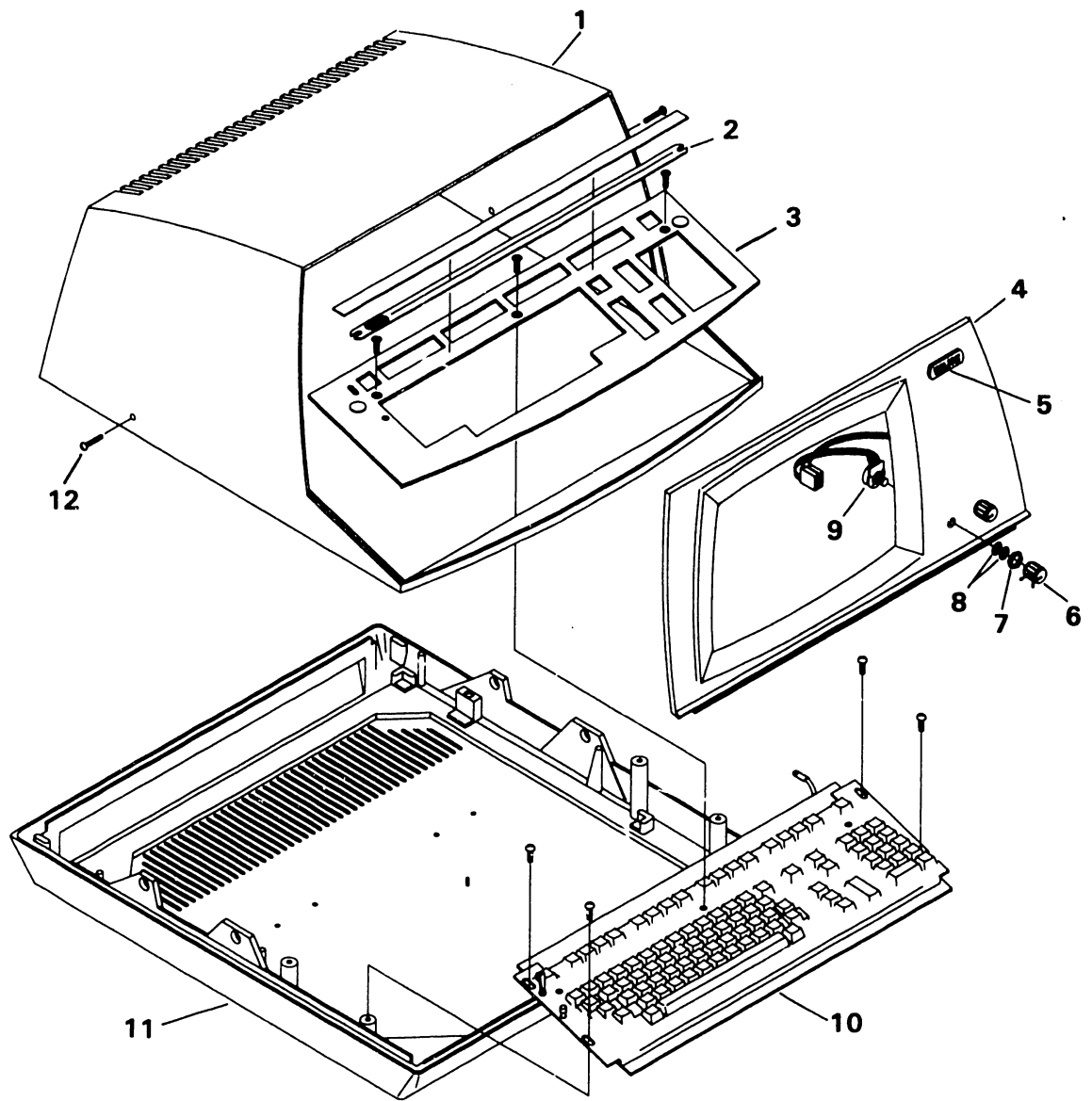

FIGURE 14 EXTERNAL COVERS ASSEMBLY

THIS PAGE IS INTENTIONALLY LEFT BLANK

12" MONITOR & 2236DE WK/ST CHASSIS ASSEMBLY

ITEM NO.	PART NO.	DESCRIPTION
1	210-7592-1A	PCA 2236DW SINGLE BD THERM ELEC
2	270-0579	HEATSINK ASSEMBLY
3	651-0037	#8x3/8" SLTD HEX S.T.SCREW
4	451-3857	SIDE PANEL (R.H.)
5	270-3092	YOKE ASSEMBLY
6	340-0108	CRT
7	270-0372	12" MONITOR ASSEMBLY
8	651-0053	#10x3/8"HEX HD S.T. SCREW
9	PART OF 7	
10	PART OF 7	
11	380-3011	20KV DIODE
12	350-2073	ANODE CONNECTOR
13	462-0413	SPACER
14	270-3104	FLYBACK TRANSFORMER ASSEMBLY
15	650-2087	4-40x1/4" SCREW
16	210-7456	PCA 12" MONITOR ELEC
17	451-1121	CHASSIS, 12"
18	451-4472	NECKSAVER BRACKET
19	478-0448	NECKSAVER BRACKET INSULATOR
20	651-0037	#8x3/8" SLTD HEX S.T. SCREW
21	651-0037	#8x3/8" SLTD HEX S.T. SCREW
22	452-4042	CARD GUIDE
23	465-1643	GROUNDING SPRING
24	651-0037	#8x3/8" SLTD HEX S.T. SCREW
25	451-4473	SUPPORT BRACKET
26	PART OF 57	
27	PART OF 57	
28	325-2117	SWITCH SLIDE DPDT 115-220
29	654-1288	SNAP BUSHING
30	451-3856	SIDE PANEL (L.H.)
31	652-0032	8-32 LOCKNUT KEPS
32	410-2005	LINE FILTER
33	652-2004	HEX NUT
34	220-1740	A.C. CABLE
35	270-0576	2236DE WK/ST CHASSIS ASSEMBLY
36	451-1100	CRT CHASSIS
37	650-3120	6-32x3/8" SCREW
38	220-3086	FLAT CABLE ASSEMBLY 2236E
39	320-0300	SQ. MAGNETIC SPEAKER
40	325-0033	TOGGLE SWITCH
41	360-9003	LOCKWASHER
42	360-9002	HEXNUT
43	336-0032	100 OHM POT
44	336-0035	250 OHM POT
45	652-2005	4-40 LOCKNUT KEPS
46	220-3085	FLAT CABLE ASSEMBLY RS/232
47	451-3996	SCREENED REAR PANEL

12" MONITOR & 2236DE WK/ST CHASSIS ASSEMBLY (CONT.)

ITEM NO.	PART NO.	DESCRIPTION
48	650-2082	4-40x1/4" FLAT HD SCREW
49	360-0000	FUSE HOLDER
50	360-1025-SB	FUSE 2 1/2 AMP 250V
51	458-0423	REAR PANEL STATIC GROUND
52	220-1076	POWER CORD ASSEMBLY
53	653-3000	FLAT WASHER #6
54	650-3120	6-32x3/8" SCREW
55	653-4002	FLAT WASHER #8
56	650-4160	8-32x1/2" SCREW
57	270-3139	TRANSFORMER ASSEMBLY
58	458-0436	SUPPORT ROD L.H.
59	458-0437	SUPPORT ROD R.H.

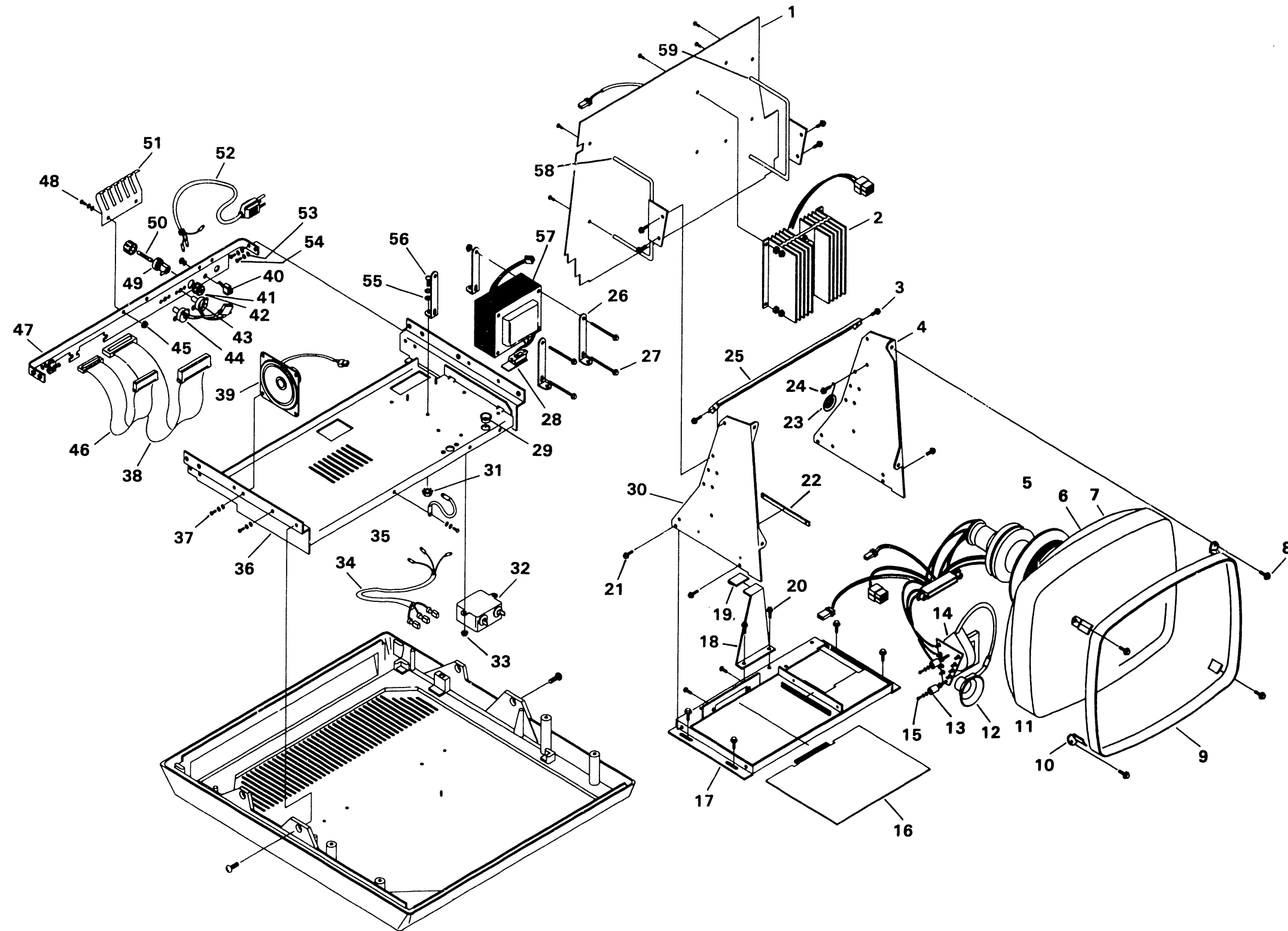

FIGURE 15 12" MONITOR & 2236DE WK/ST CHASSIS ASSEMBLY

THIS PAGE IS INTENTIONALLY LEFT BLANK

SECTION 10

SCHEMATICS

Schematics when available will be found on the last fiche of the set.

SCHEMATIC #

BOARD NAME

210-7456
210-7592
725-2613

Electronics for 9" and 12" Monitor (1 of 1)
Single Board Terminal Electronics (8 of 8)
KEYTRONICS Keyboard (1 of 1)

THIS PAGE IS INTENTIONALLY LEFT BLANK

SECTION 10

SCHEMATICS

Schematics when available will be found on the last fiche of the set.

SCHEMATIC #

BOARD NAME

210-7456
210-7592
725-2613

Electronics for 9" and 12" Monitor (1 of 1)
Single Board Terminal Electronics (8 of 8)
KEYTRONICS Keyboard (1 of 1)

77 11 10 9 8 7 5 4 3 2 1 22"

ALL DIMENSIONS IN PATENTED TOLERANCES TO BE EQUIVALENT TO INCH DIMENSIONS.

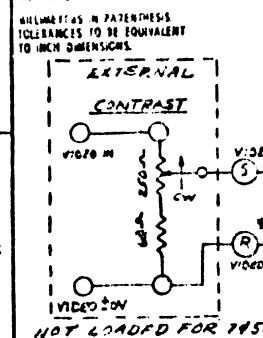

NOT LOADED FOR 7456-2

VARIATION CHART

COMP.	7456	7456-1	7456-2
R1	330-2010	330-2010	330-2010
R2	330-2010	330-2010	330-2010
R3	330-2010	330-2010	330-2010
R4	330-2010	330-2010	330-2010
R5	330-2010	330-2010	330-2010
R6	330-2010	330-2010	330-2010
R7	330-2010	330-2010	330-2010
R8	330-2010	330-2010	330-2010
R9	330-2010	330-2010	330-2010
R10	330-2010	330-2010	330-2010
R11	330-2010	330-2010	330-2010
R12	330-2010	330-2010	330-2010
R13	330-2010	330-2010	330-2010
R14	330-2010	330-2010	330-2010
R15	330-2010	330-2010	330-2010
R16	330-2010	330-2010	330-2010
R17	330-2010	330-2010	330-2010
R18	330-2010	330-2010	330-2010
R19	330-2010	330-2010	330-2010
R20	330-2010	330-2010	330-2010
R21	330-2010	330-2010	330-2010
R22	330-2010	330-2010	330-2010
R23	330-2010	330-2010	330-2010
R24	330-2010	330-2010	330-2010
R25	330-2010	330-2010	330-2010
R26	330-2010	330-2010	330-2010
R27	330-2010	330-2010	330-2010
R28	330-2010	330-2010	330-2010
R29	330-2010	330-2010	330-2010
R30	330-2010	330-2010	330-2010
R31	330-2010	330-2010	330-2010
R32	330-2010	330-2010	330-2010
R33	330-2010	330-2010	330-2010
R34	330-2010	330-2010	330-2010
R35	330-2010	330-2010	330-2010
R36	330-2010	330-2010	330-2010
R37	330-2010	330-2010	330-2010
R38	330-2010	330-2010	330-2010
R39	330-2010	330-2010	330-2010
R40	330-2010	330-2010	330-2010

COMPONENTS NOT LISTED FOR 7456-2

R9	330-2010
R1	330-2010
R11	330-2010
R12	330-2010
R14	330-2010
C3	300-1320
C15	300-1022
C5	300-1014
G2	375-056
D4,10	300-1001
C32	300-1047
Q1	375-012
R10	330-2010
R40	330-2010

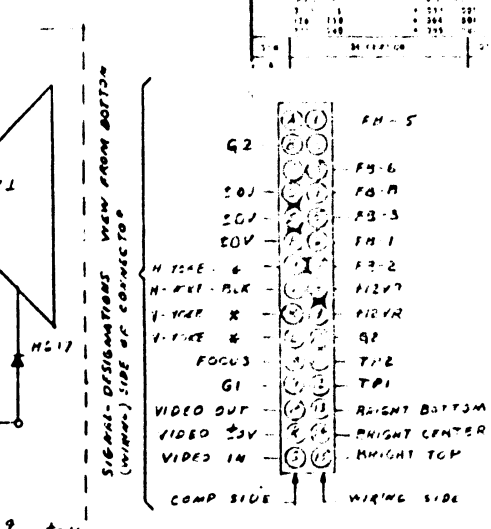
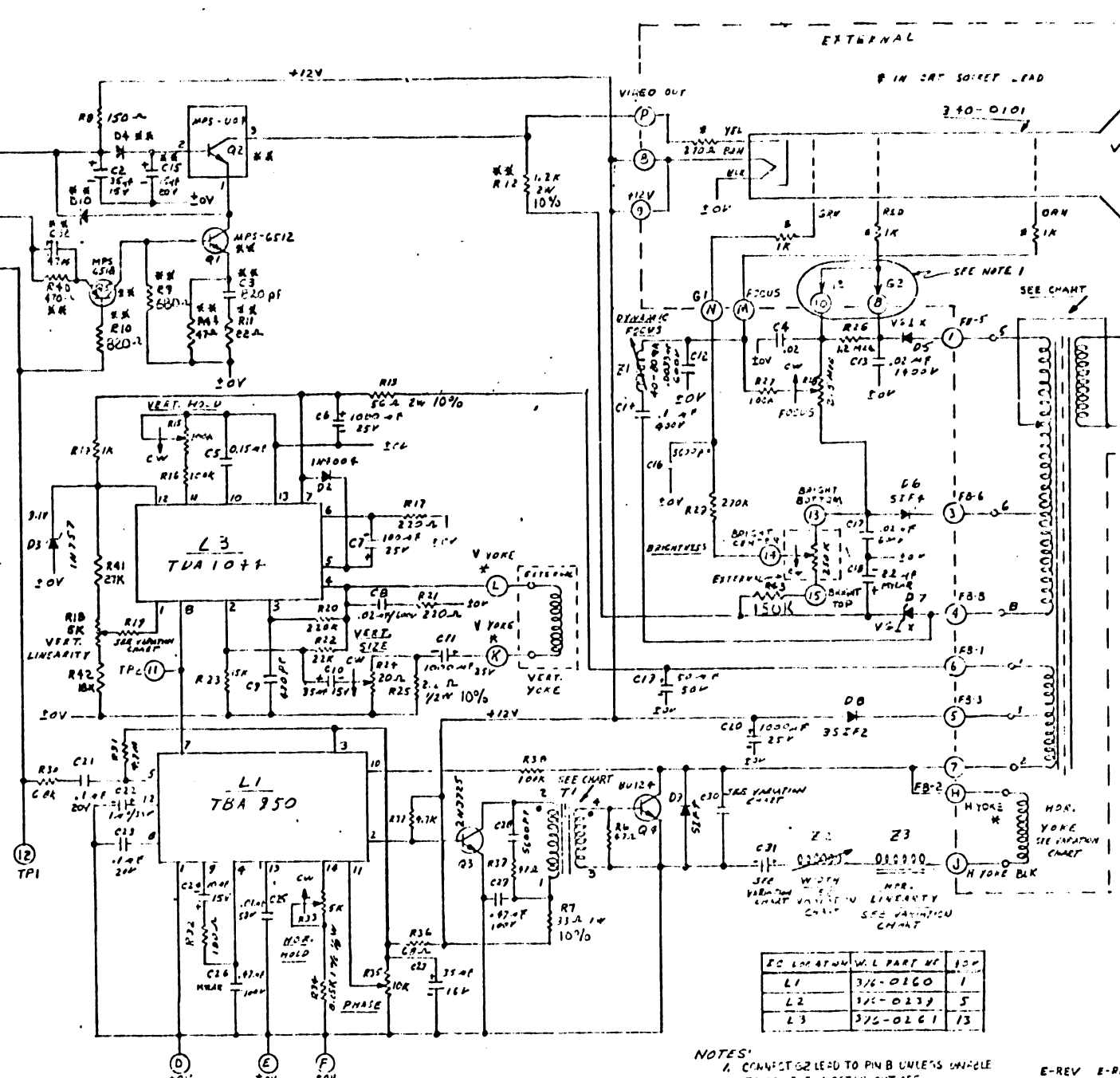
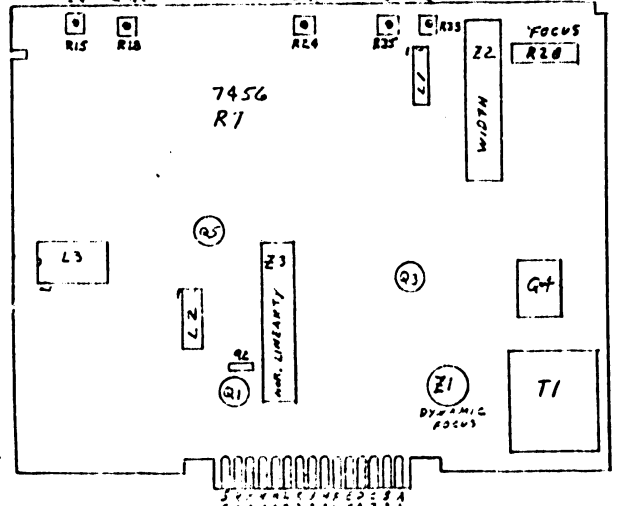

COMP.	W.	PART NO.
C1	300	300-1001
C2	300	300-1001
C3	300	300-1001
C4	300	300-1001
C5	300	300-1001
C6	300	300-1001
C7	300	300-1001
C8	300	300-1001
C9	300	300-1001
C10	300	300-1001
C11	300	300-1001
C12	300	300-1001
C13	300	300-1001
C14	300	300-1001
C15	300	300-1001
C16	300	300-1001
C17	300	300-1001
C18	300	300-1001
C19	300	300-1001
C20	300	300-1001
C21	300	300-1001
C22	300	300-1001
C23	300	300-1001
C24	300	300-1001
C25	300	300-1001
C26	300	300-1001
C27	300	300-1001
C28	300	300-1001
C29	300	300-1001
C30	300	300-1001
C31	300	300-1001
C32	300	300-1001
C33	300	300-1001
C34	300	300-1001
C35	300	300-1001
C36	300	300-1001
C37	300	300-1001
C38	300	300-1001
C39	300	300-1001
C40	300	300-1001
C41	300	300-1001
C42	300	300-1001
C43	300	300-1001
C44	300	300-1001
C45	300	300-1001
C46	300	300-1001
C47	300	300-1001
C48	300	300-1001
C49	300	300-1001
C50	300	300-1001
C51	300	300-1001
C52	300	300-1001
C53	300	300-1001
C54	300	300-1001
C55	300	300-1001
C56	300	300-1001
C57	300	300-1001
C58	300	300-1001
C59	300	300-1001
C60	300	300-1001
C61	300	300-1001
C62	300	300-1001
C63	300	300-1001
C64	300	300-1001
C65	300	300-1001
C66	300	300-1001
C67	300	300-1001
C68	300	300-1001
C69	300	300-1001
C70	300	300-1001
C71	300	300-1001
C72	300	300-1001
C73	300	300-1001
C74	300	300-1001
C75	300	300-1001
C76	300	300-1001
C77	300	300-1001
C78	300	300-1001
C79	300	300-1001
C80	300	300-1001
C81	300	300-1001
C82	300	300-1001
C83	300	300-1001
C84	300	300-1001
C85	300	300-1001
C86	300	300-1001
C87	300	300-1001
C88	300	300-1001
C89	300	300-1001
C90	300	300-1001
C91	300	300-1001
C92	300	300-1001
C93	300	300-1001
C94	300	300-1001
C95	300	300-1001
C96	300	300-1001
C97	300	300-1001
C98	300	300-1001
C99	300	300-1001
C100	300	300-1001

COMP.	W.	PART NO.
C1	300	300-1001
C2	300	300-1001
C3	300	300-1001
C4	300	300-1001
C5	300	300-1001
C6	300	300-1001
C7	300	300-1001
C8	300	300-1001
C9	300	300-1001
C10	300	300-1001
C11	300	300-1001
C12	300	300-1001
C13	300	300-1001
C14	300	300-1001
C15	300	300-1001
C16	300	300-1001
C17	300	300-1001
C18	300	300-1001
C19	300	300-1001
C20	300	300-1001
C21	300	300-1001
C22	300	300-1001
C23	300	300-1001
C24	300	300-1001
C25	300	300-1001
C26	300	300-1001
C27	300	300-1001
C28	300	300-1001
C29	300	300-1001
C30	300	300-1001
C31	300	300-1001
C32	300	300-1001
C33	300	300-1001
C34	300	300-1001
C35	300	300-1001
C36	300	300-1001
C37	300	300-1001
C38	300	300-1001
C39	300	300-1001
C40	300	300-1001
C41	300	300-1001
C42	300	300-1001
C43	300	300-1001
C44	300	300-1001
C45	300	300-1001
C46	300	300-1001
C47	300	300-1001
C48	300	300-1001
C49	300	300-1001
C50	300	300-1001
C51	300	300-1001
C52	300	300-1001
C53	300	300-1001
C54	300	300-1001
C55	300	300-1001
C56	300	300-1001
C57	300	300-1001
C58	300	300-1001
C59	300	300-1001
C60	300	300-1001
C61	300	300-1001
C62	300	300-1001
C63	300	300-1001
C64	300	300-1001
C65	300	300-1001
C66	300	300-1001
C67	300	300-1001
C68	300	300-1001
C69	300	300-1001
C70	300	300-1001
C71	300	300-1001
C72	300	300-1001
C73	300	300-1001
C74	300	300-1001
C75	300	300-1001
C76	300	300-1001
C77	300	300-1001
C78	300	300-1001
C79	300	300-1001
C80	300	300-1001
C81	300	300-1001
C82	300	300-1001
C83	300	300-1001
C84	300	300-1001
C85	300	300-1001
C86	300	300-1001
C87	300	300-1001
C88	300	300-1001
C89	300	300-1001
C90	300	300-1001
C91	300	300-1001
C92	300	300-1001
C93	300	300-1001
C94	300	300-1001
C95	300	300-1001
C96	300	300-1001
C97	300	300-1001
C98	300	300-1001
C99	300	300-1001
C100	300	300-1001

EC	EMATN	W.L	PART NO.	TOP
L1	375	0260	1	
L2	375	0239	5	
L3	375	0261	13	

NOTES:
1. CONNECT G2 LEAD TO PIN B UNLESS UNABLE TO ACHIEVE HASTER CUT OFF.

E-REV E-REV E-REV
7456 7456-1 7456-2
6 5 1

REVISION	DATE	BY	DESCRIPTION
1	10/15/56	WANG	INITIAL DESIGN
2	10/20/56	WANG	REVISED PER APP'D: W/10/20/56
3	10/25/56	WANG	REVISED PER APP'D: W/10/25/56
4	11/01/56	WANG	REVISED PER APP'D: W/11/01/56
5	11/05/56	WANG	REVISED PER APP'D: W/11/05/56
6	11/10/56	WANG	REVISED PER APP'D: W/11/10/56
7	11/15/56	WANG	REVISED PER APP'D: W/11/15/56
8	11/20/56	WANG	REVISED PER APP'D: W/11/20/56
9	11/25/56	WANG	REVISED PER APP'D: W/11/25/56
10	12/01/56	WANG	REVISED PER APP'D: W/12/01/56
11	12/05/56	WANG	REVISED PER APP'D: W/12/05/56
12	12/10/56	WANG	REVISED PER APP'D: W/12/10/56
13	12/15/56	WANG	REVISED PER APP'D: W/12/15/56
14	12/20/56	WANG	REVISED PER APP'D: W/12/20/56
15	12/25/56	WANG	REVISED PER APP'D: W/12/25/56

THIS DRAWING IS THE PROPERTY OF WANG LABORATORIES, INC. AND IS NOT TO BE REPRODUCED OR TRANSMITTED IN ANY FORM OR BY ANY MEANS, ELECTRONIC OR MECHANICAL, INCLUDING PHOTOCOPYING, RECORDING, OR BY ANY INFORMATION STORAGE AND RETRIEVAL SYSTEM. ANY UNAUTHORIZED REPRODUCTION OR TRANSMISSION OF THIS DRAWING IS PROHIBITED. THE USER OF THIS DRAWING AGREES TO HOLD WANG LABORATORIES, INC. HARMLESS FROM AND AGAINST ALL LIABILITY FOR ANY AND ALL DAMAGES, INCLUDING REASONABLE ATTORNEY'S FEES, THAT MAY BE INCURRED BY WANG LABORATORIES, INC. AS A RESULT OF THE USER'S REPRODUCTION OR TRANSMISSION OF THIS DRAWING. THE USER OF THIS DRAWING AGREES TO HOLD WANG LABORATORIES, INC. HARMLESS FROM AND AGAINST ALL LIABILITY FOR ANY AND ALL DAMAGES, INCLUDING REASONABLE ATTORNEY'S FEES, THAT MAY BE INCURRED BY WANG LABORATORIES, INC. AS A RESULT OF THE USER'S REPRODUCTION OR TRANSMISSION OF THIS DRAWING.

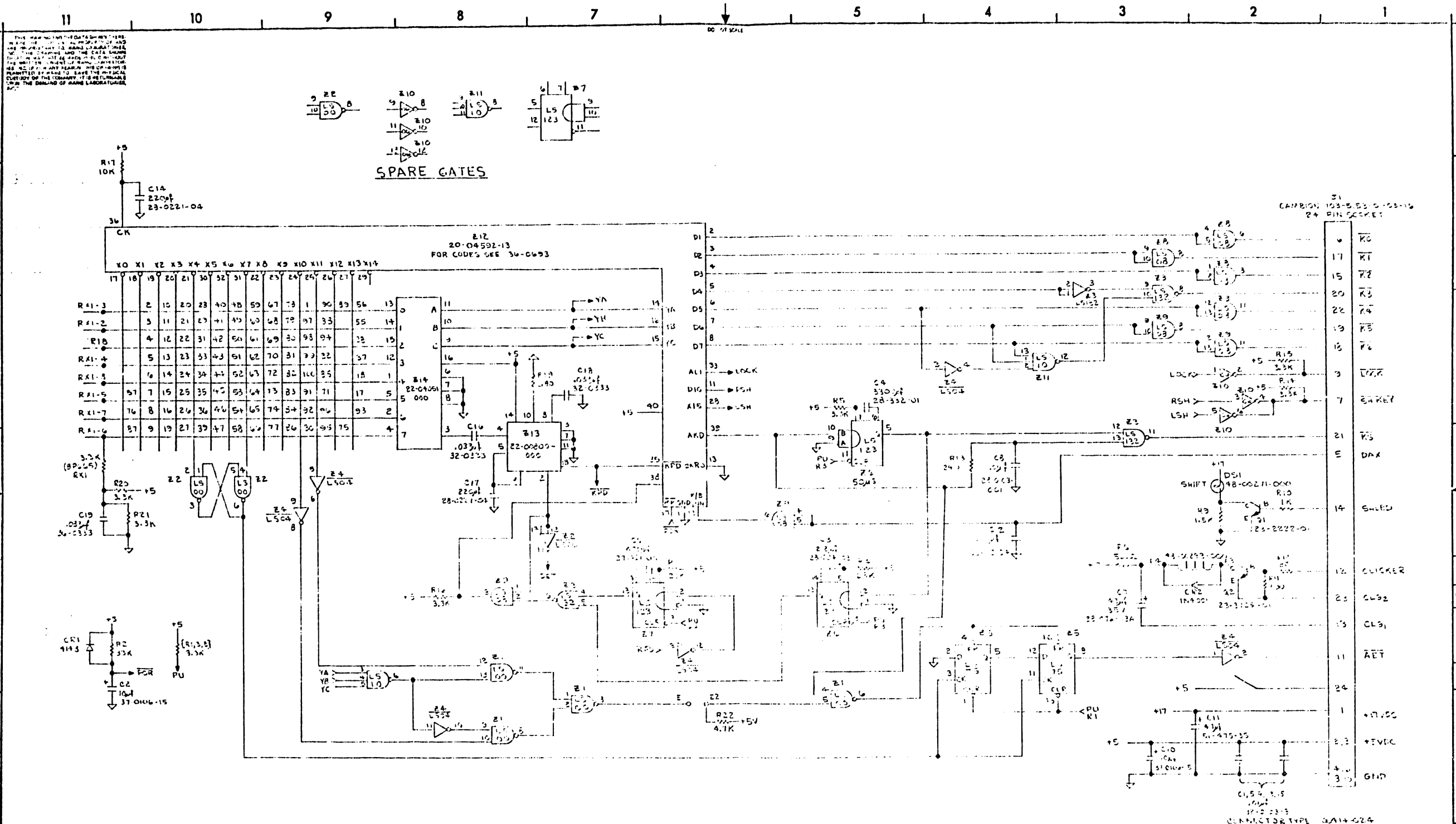

NO.	REVISION	DATE	BY	APPROVED BY
1	ORIGINAL FOR			
2	REVISED FOR			
3	REVISED FOR			
4	REVISED FOR			
5	REVISED FOR			

WANG LABORATORIES, INC. LIMITEE WANG 100		BY	DATE	APPROVED BY	DATE
MATERIAL	MODEL NO. C10	DWN	2/7/68	E ENGR	2/7/68
	SHEET NO. 1 OF 1	CHE	2/7/68	M ENGR	2/7/68
FINISH	TOL. TO AS NOTED			WFS ENGR	
	FIN. TO SPEC. FINISH	TITLE KEYTRONICS KEYBOARD			
	DATE	7-22-67	D	12-5-67	1
	WANG PART NUMBER	SIZE	DRAWING NAME	REV.	

THIS DRAWING AND THE DATA SHOWN THEREIN ARE THE PROPERTY OF WANG LABORATORIES, INC. AND ARE TO BE KEPT CONFIDENTIAL. NO PART OF THIS DRAWING IS TO BE REPRODUCED OR TRANSMITTED IN ANY FORM OR BY ANY MEANS, ELECTRONIC OR MECHANICAL, INCLUDING PHOTOCOPYING, RECORDING, OR BY ANY INFORMATION STORAGE AND RETRIEVAL SYSTEM, WITHOUT THE WRITTEN PERMISSION OF WANG LABORATORIES, INC. IT IS THE POLICY OF WANG LABORATORIES, INC. TO MAKE AVAILABLE TO THE GENERAL PUBLIC THE INFORMATION CONTAINED IN THIS DRAWING IN CONNECTION WITH THE SALE OF THE COMPUTER SYSTEM TO WHICH THIS DRAWING RELATES.

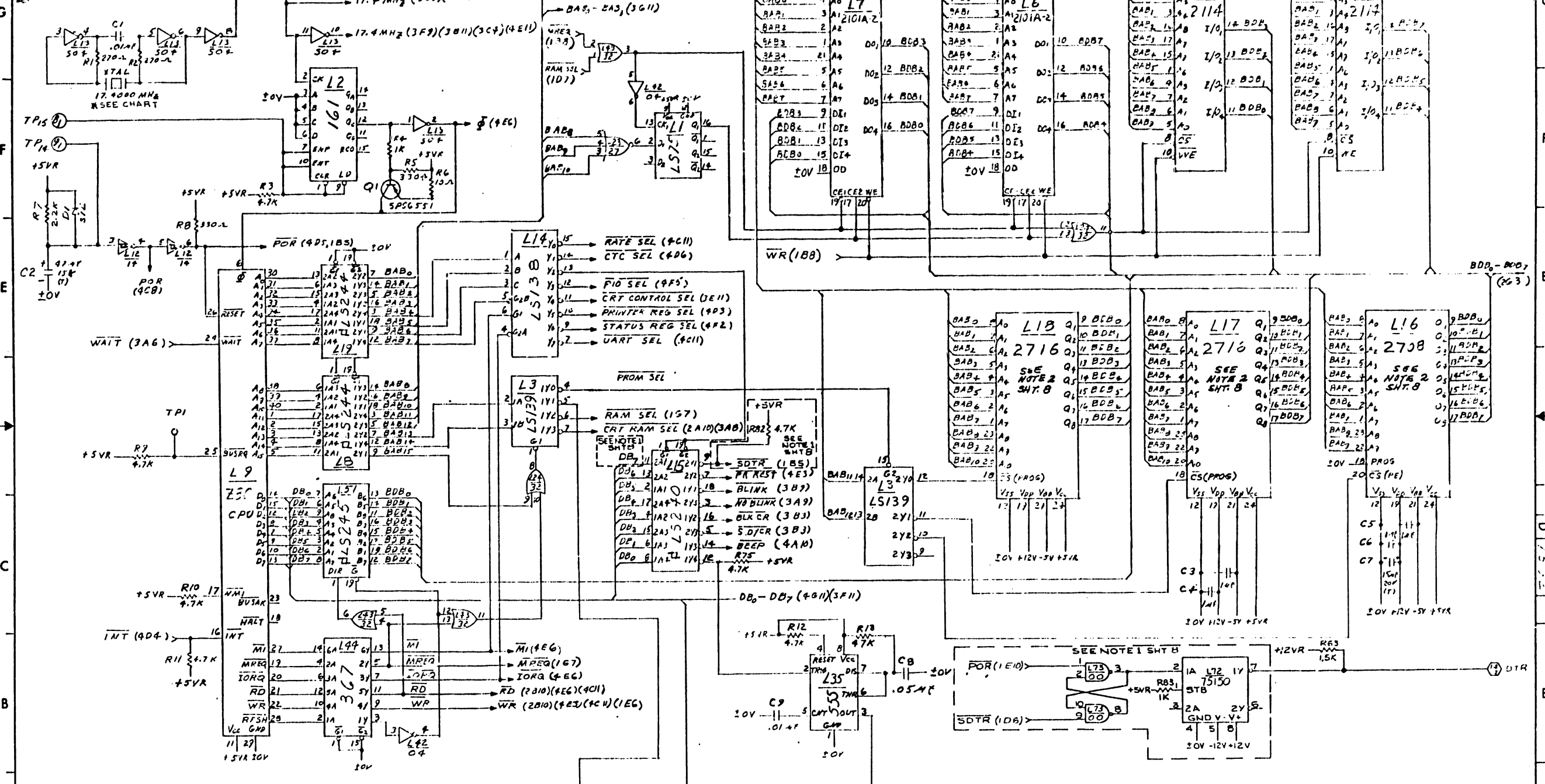

REVISION	DATE	BY	APPROVED BY
1	1-7-78	J. ENGEL	
2	1-7-78	J. ENGEL	

WANG LABORATORIES, INC. MODEL NO. 2236 E TITLE SINGLE BOARD TERMINAL ELECTRONICS		BY	DATE	APPROVED BY	DATE
		J. ENGEL	6/97	J. ENGEL	
FINISH	SCALE	SEE CHART D 7592			

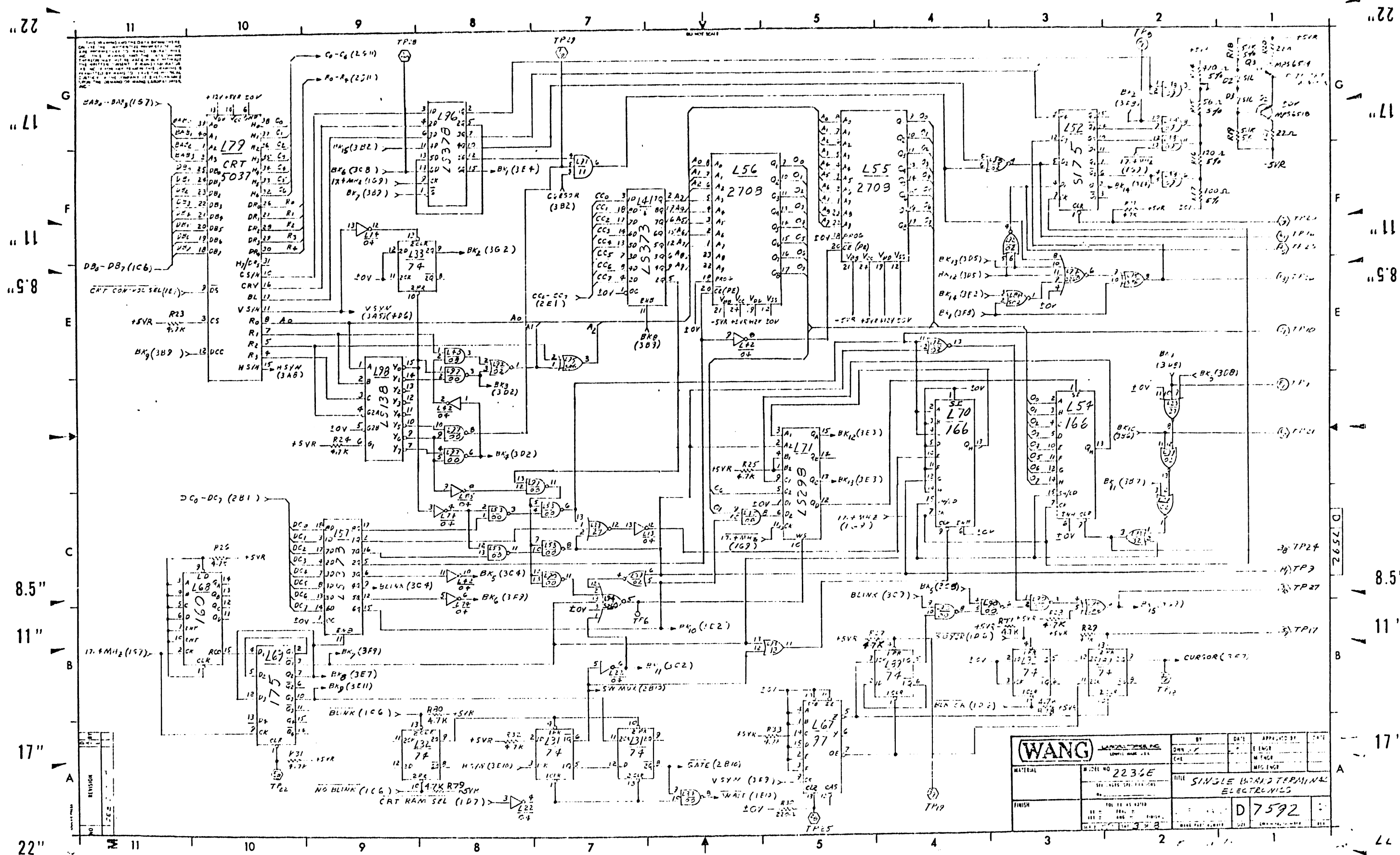

THIS DRAWING IS THE DATA SHEET FOR THE MODEL 2236E TERMINAL. IT IS NOT TO BE USED FOR REPAIR OR MODIFICATION. THE MODEL 2236E TERMINAL IS A TRADE SECRET OF WANG LABORATORIES. THE INFORMATION CONTAINED HEREIN IS UNCLASSIFIED EXCEPT WHERE SHOWN OTHERWISE. DATE: 11/15/73 BY: [REDACTED]

(WANG) WANG LABORATORIES LOWELL, MASS. U.S.A.		BY	DATE	APPROVED BY	DATE
		CHKD		ENGR	
MATERIAL		MODEL NO	TITLE		
		2236E	SINGLE BOARD TERMINAL ELECTRONICS		
FINISH		REV	D 7592		
		1			

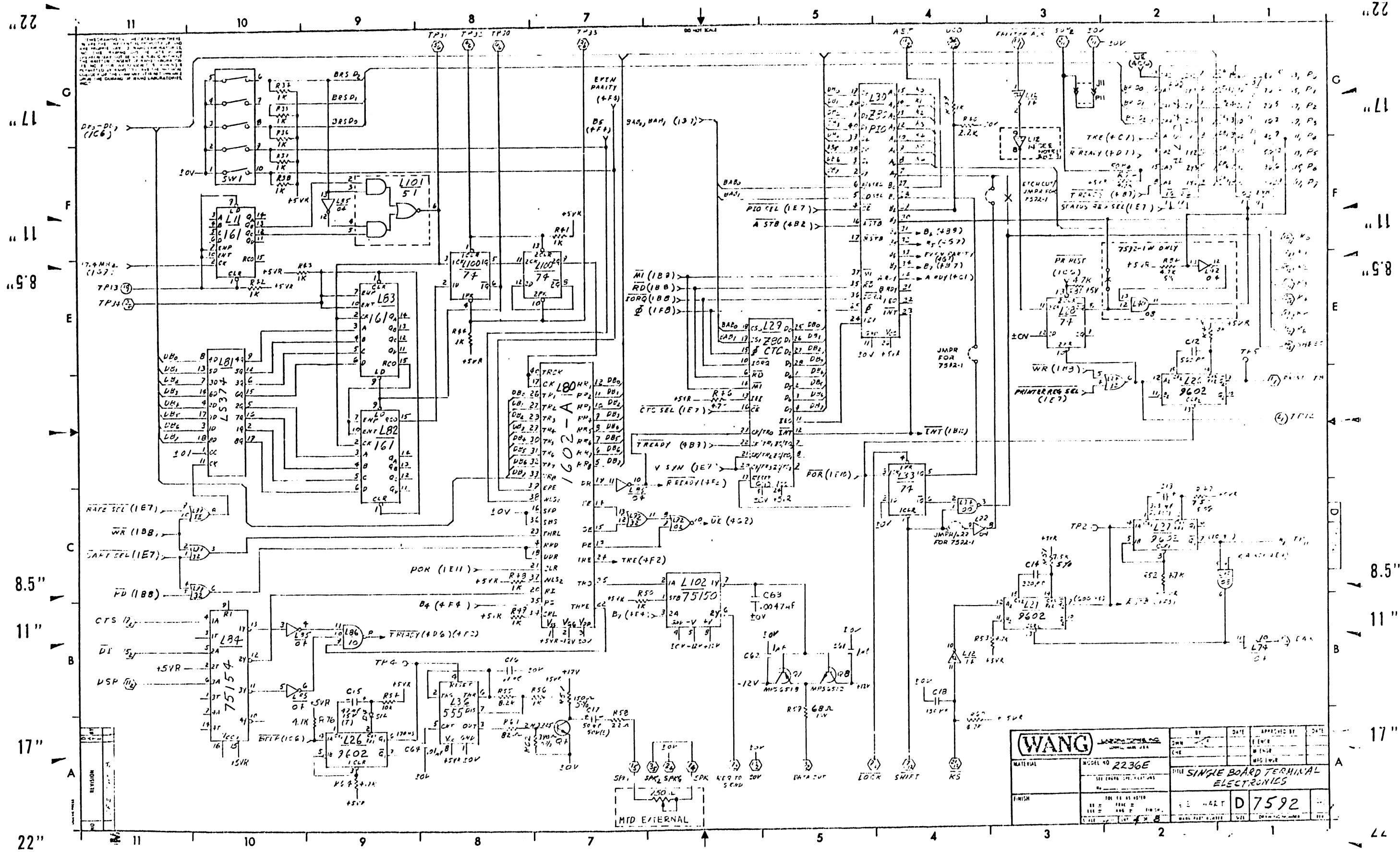

(WANG)		DATE	APPROVED BY	DATE
MATERIAL	MODEL NO. 2236E	DATE	ENGINEER	
SEE DRAWING FOR PARTS LIST		DATE	DESIGNER	
TITLE SINGLE BOARD TERMINAL ELECTRONICS		DATE	TESTER	
FINISH	REV. 11 AS 1010	DATE	DATE	
	REV. 2	DATE	DATE	
	REV. 3	DATE	DATE	
	REV. 4	DATE	DATE	
	REV. 5	DATE	DATE	
	REV. 6	DATE	DATE	
	REV. 7	DATE	DATE	
	REV. 8	DATE	DATE	
	REV. 9	DATE	DATE	
	REV. 10	DATE	DATE	
	REV. 11	DATE	DATE	

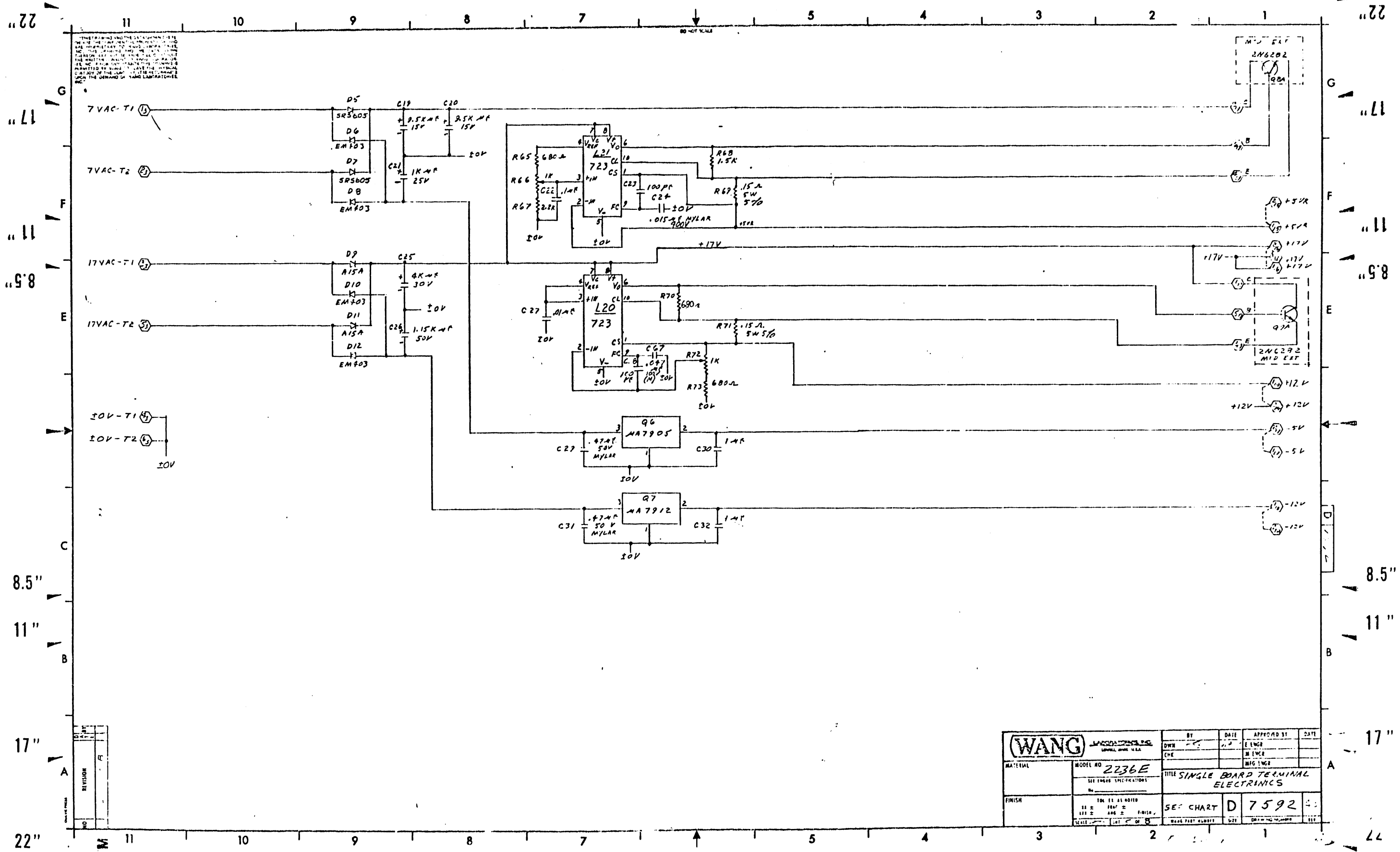

THIS DRAWING AND THE EQUIPMENT TO WHICH IT APPLIES ARE THE PROPERTY OF WANG LABORATORIES, INC. AND ARE TO BE KEPT IN CONFIDENTIALITY TO WANG LABORATORIES, INC. ANY REPRODUCTION OR DISSEMINATION OF THIS DRAWING OR THE EQUIPMENT TO WHICH IT APPLIES WITHOUT THE WRITTEN PERMISSION OF WANG LABORATORIES, INC. IS PROHIBITED. THE INFORMATION CONTAINED HEREIN IS UNCLASSIFIED EXCEPT WHERE SHOWN OTHERWISE. DATE 01-15-80 BY SP-1/BJL/STP

REV	DATE	BY	DESCRIPTION
1			
2			
3			
4			
5			
6			
7			
8			
9			
10			
11			

(WANG) WANG LABORATORIES, INC. WANG LAB. BLDG. 1000 W. 42ND ST. NEW YORK, N.Y. 10018 U.S.A.		BY	DATE	APPROVED BY	DATE
MATERIAL	MODEL NO. 2236E	DWR	11/3	E ENGR	
	SEE ENG'G SPECIFICATIONS	CHE		M ENGR	
FINISH	TOL. IS AS NOTED UNLESS OTHERWISE SPECIFIED			MFG ENGR	
	SCALE 1:1 (SEE DRAWING)	SEC. CHART	D	7592	3
		WANG PART NUMBER	SIZE	DATE	REV.

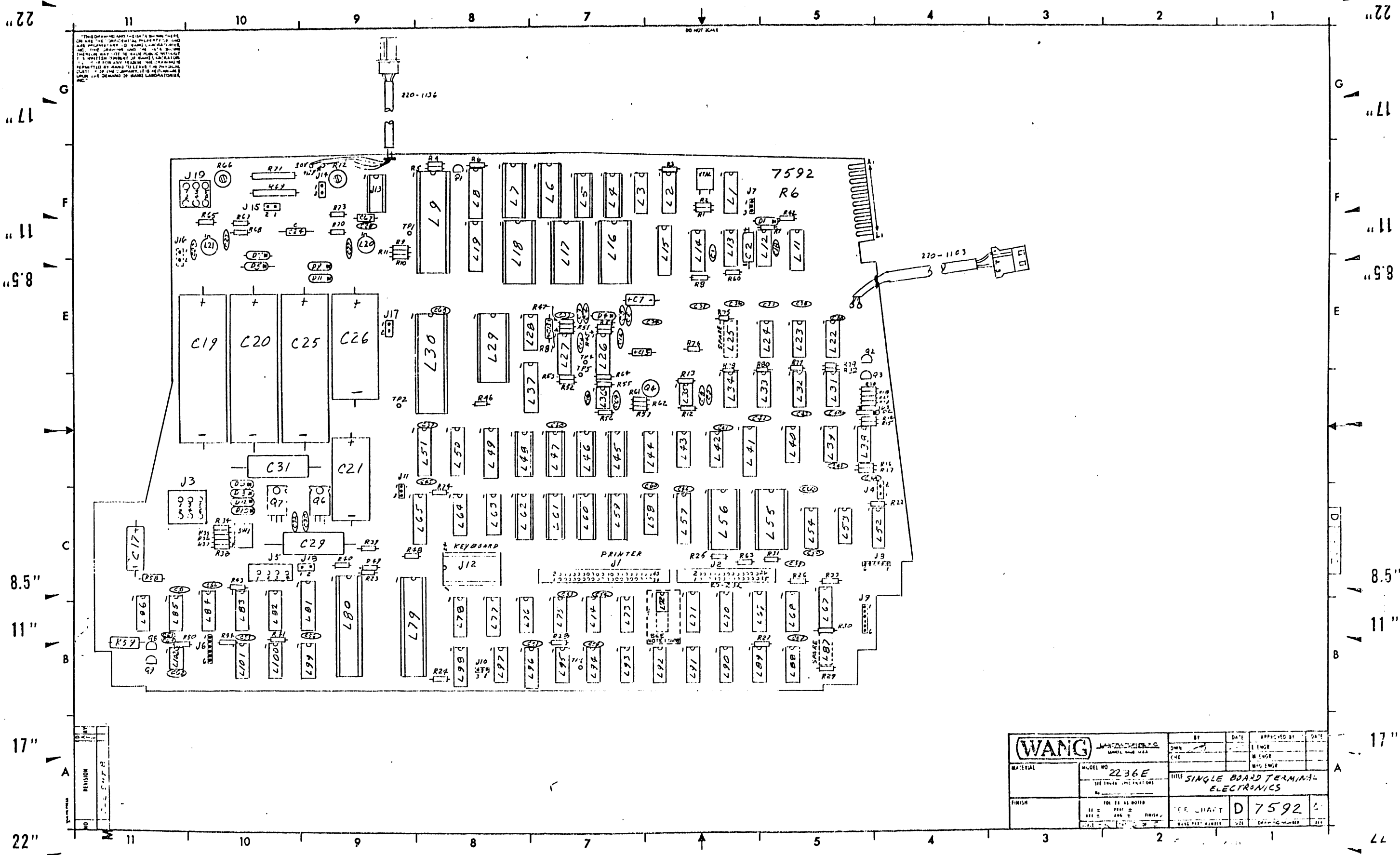

THIS DRAWING AND DATA IS UNCLASSIFIED UNLESS THE SOURCE OF THE INFORMATION IS A PROPRIETARY OR CONFIDENTIAL SOURCE. THE INFORMATION IS UNCLASSIFIED UNLESS THE SOURCE OF THE INFORMATION IS A PROPRIETARY OR CONFIDENTIAL SOURCE. THE INFORMATION IS UNCLASSIFIED UNLESS THE SOURCE OF THE INFORMATION IS A PROPRIETARY OR CONFIDENTIAL SOURCE.

REV	DATE	DESCRIPTION
1		
2		
3		
4		

(WANG)		BY	DATE	APPROVED BY	DATE
MATERIAL	MODEL NO 2236E	OWN		ENGR	
	WE ENGR SPECIFICATIONS	ENR		M ENGR	
				MIS ENGR	
FINISH	FOR USE AS NOTED	SEE CHART	D	7592	4
	SEE ENGR SPECIFICATIONS	DATE		DATE	

THIS DRAWING AND THE DATA SHOWN THEREON ARE THE PROPRIETARY PROPERTY OF AND ARE CONFIDENTIAL TO WANG LABORATORIES, INC. THE USER OF THIS DRAWING SHALL BE RESPONSIBLE FOR OBTAINING ALL NECESSARY PERMITS AND AUTHORIZATIONS FROM THE APPROPRIATE AGENCIES AND LOCAL AUTHORITIES. WANG LABORATORIES, INC. IS NOT RESPONSIBLE FOR ANY DAMAGE TO PROPERTY OR PERSONS THAT MAY BE CAUSED BY THE USE OF THIS DRAWING OR THE DATA SHOWN THEREON.

210 = 209 + 378 OR 377

210	209	145, 15, 19, 20	L9	L16	L17	L18	L29	L30	L55	L56	L79	L80	L6	L7
2235 CW 7592-1A	7592-1	377-0341-L	377-0344	378-3067-R1	378-4095-R4	378-4094-R4	377-0343	377-0342	378-2447-R1	377-0323	377-0372	377-0071	377-0308	377-0308
7592-A	7592	377-0341-L	377-0344	378-2446-R2	378-4095-R4	378-4094-R4	377-0343	377-0342	378-2447-R1	377-0323	377-0372	377-0071	377-0308	377-0308
AZERI 7592-B	7592	377-0341-L	377-0344	378-2620	378-4095-R4	378-4094-R4	377-0343	377-0342	378-2447-R1	377-0323	377-0372	377-0071	377-0308	377-0308
SWEDISH 7592-C	7592	377-0341-L	377-0344	378-2629	378-4095-R4	378-4094-R4	377-0343	377-0342	378-2447-R1	377-0323	377-0372	377-0071	377-0308	377-0308
J.K. 7592-D	7592	377-0341-L	377-0344	378-2627	378-4095-R4	378-4094-R4	377-0343	377-0342	378-2447-R1	377-0323	377-0372	377-0071	377-0308	377-0308
GERMAN 7592-E	7592	377-0341-L	377-0344	378-2628	378-4095-R4	378-4094-R4	377-0343	377-0342	378-2447-R1	377-0323	377-0372	377-0071	377-0308	377-0308
SWISS/GER. 7592-F	7592	377-0341-L	377-0344	378-2626-R1	378-4095-R4	378-4094-R4	377-0343	377-0342	378-2447-R1	377-0323	377-0372	377-0071	377-0308	377-0308
SWISS/FR. 7592-G	7592	377-0341-L	377-0344	378-2625-R1	378-4095-R4	378-4094-R4	377-0343	377-0342	378-2447-R1	377-0323	377-0372	377-0071	377-0308	377-0308
NL 7592-H	7592	377-0341-L	377-0344	378-2630	378-4095-R4	378-4094-R4	377-0343	377-0342	378-2447-R1	377-0323	377-0372	377-0071	377-0308	377-0308
NO 7592-I	7592	377-0341-L	377-0344	378-2622	378-4095-R4	378-4094-R4	377-0343	377-0342	378-2447-R1	377-0323	377-0372	377-0071	377-0308	377-0308
CYRILLIC 7592-K	7592	377-0341-L	377-0344	378-2628	378-4095-R4	378-4094-R4	377-0343	377-0342	378-2447-R1	377-0323	377-0372	377-0071	377-0308	377-0308
DANISH 7592-L	7592	377-0341-L	377-0344	378-2623	378-4095-R4	378-4094-R4	377-0343	377-0342	378-2447-R1	377-0323	377-0372	377-0071	377-0308	377-0308
GR/LT 7592-M	7592	377-0341-L	377-0344	378-2621-R1	378-4095-R4	378-4094-R4	377-0343	377-0342	378-2447-R1	377-0323	377-0372	377-0071	377-0308	377-0308
AL 7592-N	7592	377-0341-L	377-0344	378-2647	378-4095-R4	378-4094-R4	377-0343	377-0342	378-2447-R1	377-0323	377-0372	377-0071	377-0308	377-0308
DIAG. 7592-P	7592	377-0341-L	377-0344	378-2519	378-4095-R4	378-4094-R4	377-0343	377-0342	378-2447-R1	377-0323	377-0372	377-0071	377-0308	377-0308
KATAKANA 7592-Q	7592	377-0341-L	377-0344	378-2500	378-4095-R4	378-4094-R4	377-0343	377-0342	378-2447-R1	377-0323	377-0372	377-0071	377-0308	377-0308
EURO-SPAN. 7592-R	7592	377-0341-L	377-0344	378-2673	378-4095-R4	378-4094-R4	377-0343	377-0342	378-2447-R1	377-0323	377-0372	377-0071	377-0308	377-0308
REPAIR 7592-S	7592	377-0341-L	377-0344	378-2673	378-4227	378-4226	377-0343	377-0342	378-2447-R1	377-0323	377-0372	377-0071	377-0308	377-0308
ICELANDIC 7592-T	7592	377-0341-L	377-0344	378-2706	378-4095-R4	378-4094-R4	377-0343	377-0342	378-2447-R1	377-0323	377-0372	377-0071	377-0308	377-0308
CANADIAN 7592-U	7592	377-0341-L	377-0344	378-2716-R1	378-4095-R4	378-4094-R4	377-0343	377-0342	378-2447-R1	377-0323	377-0372	377-0071	377-0308	377-0308
7592-1B	7592	377-0341-L	377-0344	378-3068-R1	378-4095-R4	378-4094-R4	377-0343	377-0342	378-2447-R1	377-0323	377-0372	377-0071	377-0308	377-0308
7592-1C	7592	377-0341-L	377-0344	378-3063	378-4226	378-4261	377-0343	377-0342	378-2447-R1	377-0323	377-0372	377-0071	377-0308	377-0308
7592-1D	7592-1			378-3067	378-4095-R4	378-4094-R4			378-2447-R1	377-0323	377-0372	377-0071	377-0308	377-0308
7592-1E	7592-1			378-3067	378-4095-R4	378-4094-R4			378-2447-R1	377-0323	377-0372	377-0071	377-0308	377-0308
7592-1F	7592-1	377-0341-L	377-0344	378-2729	378-4095-R4	378-4094-R4	377-0343	377-0342	378-2447-R1	377-0323	377-0372	377-0071	377-0308	377-0308
7592-1G	7592-1	377-0341-L	377-0344	378-2730	378-4095-R4	378-4094-R4	377-0343	377-0342	378-2447-R1	377-0323	377-0372	377-0071	377-0308	377-0308
7592-1H	7592-1	377-0341-L	377-0344	378-2740-R1	378-4095-R4	378-4094-R4	377-0343	377-0342	378-2447-R1	377-0323	377-0372	377-0071	377-0308	377-0308
7592-1J	7592-1	377-0341-L	377-0344	378-2741	378-4095-R4	378-4094-R4	377-0343	377-0342	378-2447-R1	377-0323	377-0372	377-0071	377-0308	377-0308
7592-1K	7592-1	377-0341-L	377-0344	378-2742	378-4095-R4	378-4094-R4	377-0343	377-0342	378-2447-R1	377-0323	377-0372	377-0071	377-0308	377-0308
7592-1L	7592-1	377-0341-L	377-0344	378-2743	378-4095-R4	378-4094-R4	377-0343	377-0342	378-2447-R1	377-0323	377-0372	377-0071	377-0308	377-0308
7592-1M	7592-1	377-0341-L	377-0344	378-2744	378-4095-R4	378-4094-R4	377-0343	377-0342	378-2447-R1	377-0323	377-0372	377-0071	377-0308	377-0308
7592-1N	7592-1	377-0341-L	377-0344	378-2745	378-4095-R4	378-4094-R4	377-0343	377-0342	378-2447-R1	377-0323	377-0372	377-0071	377-0308	377-0308
7592-1O	7592-1	377-0341-L	377-0344	378-2746	378-4095-R4	378-4094-R4	377-0343	377-0342	378-2447-R1	377-0323	377-0372	377-0071	377-0308	377-0308
7592-1P	7592-1	377-0341-L	377-0344	378-2747	378-4095-R4	378-4094-R4	377-0343	377-0342	378-2447-R1	377-0323	377-0372	377-0071	377-0308	377-0308
7592-1R	7592-1	377-0341-L	377-0344	378-2748	378-4095-R4	378-4094-R4	377-0343	377-0342	378-2447-R1	377-0323	377-0372	377-0071	377-0308	377-0308
7592-1S	7592-1	377-0341-L	377-0344	378-2749	378-4095-R4	378-4094-R4	377-0343	377-0342	378-2447-R1	377-0323	377-0372	377-0071	377-0308	377-0308
7592-1T	7592-1	377-0341-L	377-0344	378-2750	378-4095-R4	378-4094-R4	377-0343	377-0342	378-2447-R1	377-0323	377-0372	377-0071	377-0308	377-0308
7592-1U	7592-1	377-0341-L	377-0344	378-2751	378-4095-R4	378-4094-R4	377-0343	377-0342	378-2447-R1	377-0323	377-0372	377-0071	377-0308	377-0308
7592-1V	7592-1	377-0341-L	377-0344	378-2752	378-4095-R4	378-4094-R4	377-0343	377-0342	378-2447-R1	377-0323	377-0372	377-0071	377-0308	377-0308
7592-1W	7592-1	377-0341-L	377-0344	378-2753	378-4095-R4	378-4094-R4	377-0343	377-0342	378-2447-R1	377-0323	377-0372	377-0071	377-0308	377-0308
7592-1X	7592-1	377-0341-L	377-0344	378-2754	378-4095-R4	378-4094-R4	377-0343	377-0342	378-2447-R1	377-0323	377-0372	377-0071	377-0308	377-0308
7592-1Y	7592-1	377-0341-L	377-0344	378-2755	378-4095-R4	378-4094-R4	377-0343	377-0342	378-2447-R1	377-0323	377-0372	377-0071	377-0308	377-0308
7592-1Z	7592-1	377-0341-L	377-0344	378-2756	378-4095-R4	378-4094-R4	377-0343	377-0342	378-2447-R1	377-0323	377-0372	377-0071	377-0308	377-0308
7592-2A	7592	377-0341-L	377-0344	378-2757	378-4095-R4	378-4094-R4	377-0343	377-0342	378-2447-R1	377-0323	377-0372	377-0071	377-0308	377-0308
7592-2B	7592	377-0341-L	377-0344	378-2758	378-4095-R4	378-4094-R4	377-0343	377-0342	378-2447-R1	377-0323	377-0372	377-0071	377-0308	377-0308

WANG	DATE	APPROVED BY	DATE
	_____	_____	_____
MATERIAL	MODEL NO. 22365	TYPICAL SINGLE BOARD TERMINAL ELECTRONICS	
FINISH	SEE CHART D 7592		

WANG

LABORATORIES, INC.

ONE INDUSTRIAL AVENUE, LOWELL, MASSACHUSETTS 01851. TEL (617) 459-5000. TWX 710 343-6769. TELEX 94-7421

PRINTED IN U.S.A.

END