

The logo consists of the word "WANG" in a bold, white, sans-serif font, centered within a black, rounded rectangular background.

VS-75E COMPUTER SYSTEM

COMPANY PROPRIETARY STATEMENT

This document is the property of Wang Laboratories, Inc. All information contained herein is considered Company Proprietary, and its use is restricted solely to assisting you in servicing Wang products. Neither this document nor its contents may be disclosed, copied, revealed, or used in whole or in part for any other purpose without the prior written permission of Wang Laboratories, Inc. This document must be returned upon request of Wang Laboratories, Inc.

**Technical Publications
Customer Service
Product Maintenance Manual**

741-1764

COMPANY CONFIDENTIAL

PREFACE

This document is the Illustrated Product Maintenance manual for the Wang VS 75E Computer System. The manual is organized in accordance with Customer Engineering Technical Documentation's approved PMM outline. The scope of this manual reflects the type of maintenance philosophy selected for this product.

The purpose of this manual is to provide the Wang-trained Customer Engineer (CE) with sufficient instructions to operate, troubleshoot, and repair the VS 75E Computer System. The manual will be updated on a regular schedule or as necessary. Such updates will be published either as Publication Update Bulletins (PUBs) or as full revisions.

First Edition (December 1987)

Use of the material in this document is authorized only for the purpose stated in the Preface, above.

Copyright 1987 by Wang Laboratories, Inc.

WARNING

DO NOT OPEN THE SWITCHING POWER SUPPLY UNDER ANY CIRCUMSTANCE. EXTREMELY DANGEROUS VOLTAGE AND CURRENT LEVELS, IN EXCESS OF 300 VOLTS DC AND UNLIMITED CURRENT, ARE PRESENT WITHIN THE POWER SUPPLY.

DO NOT ATTEMPT TO REPAIR THE POWER SUPPLY. IT IS FIELD REPLACEABLE ONLY.

AFTER POWERING THE UNIT DOWN AND DISCONNECTING THE AC POWER PLUG FROM THE WALL OUTLET, ALLOW ONE MINUTE BEFORE REMOVING THE POWER SUPPLY TO PROVIDE ADEQUATE TIME FOR ANY RESIDUAL VOLTAGE TO DRAIN THROUGH THE BLEEDER RESISTORS.

WARNING

THIS COMPUTER EQUIPMENT HAS BEEN VERIFIED AS FCC CLASS A

IN ORDER TO MAINTAIN COMPLIANCE WITH FCC CLASS A VERIFICATION, THE FOLLOWING CONDITIONS MUST BE ADHERED TO DURING NORMAL OPERATION OF EQUIPMENT

- ALL COVERS MUST BE ON THE SYSTEM AND SECURED IN THE PROPER MANNER.
 - ALL INTERNAL CABLES MUST BE ROUTED IN THE ORIGINAL MANNER WITHIN THE CABLE CLAMPS PROVIDED FOR THAT PURPOSE.
 - ALL EXTERNAL CABLES MUST BE SECURED AND THE PROPER CABLE USED TO ENSURE THAT CABLE SHIELDING IS PROPERLY GROUNDED TO THE CABLE CLAMPS PROVIDED.
 - ALL HARDWARE IS PROPERLY SECURED.
-

TABLE OF CONTENTS

SECTION 1 INTRODUCTION

	<u>Page</u>
1.1 SCOPE AND PURPOSE	1-1
1.2 ORGANIZATION AND LAYOUT	1-2
1.3 ABBREVIATIONS AND SYMBOLS USED IN THIS MANUAL	1-3

SECTION 2 IDENTIFICATION

	<u>Page</u>
2.1 MAJOR ASSEMBLIES	2-1
2.1.1 System Components	2-1
2.2 VS-75E COMPUTER MAJOR PARTS (FRONT VIEW)	2-2
2.3 VS-75E MAJOR PARTS (REAR VIEW)	2-3

TABLE OF CONTENTS

SECTION 3 CONTROLS AND INDICATORS

	<u>Page</u>
3.1 OPERATOR CONTROLS	3-1
3.1.1 Front Panel Controls	3-1
3.1.2 TC Front Panel Controls (Optional)	3-3
3.2 OPERATOR INDICATORS	3-5
3.2.1 Front Panel Indicators	3-5
3.2.2 TC Front Panel Indicators (Optional)	3-7
3.3 SERVICE CONTROLS	3-8
3.3.1 Power Supply Controls (2 sheets)	3-8
3.3.2 1-Port TC DA (25V76-1) Controls	3-11
3.3.3 2-Port TC DA (25V76-2) Controls	3-12
3.3.4 Bus Processor (BP) Controls	3-13
3.3.5 SMD 2-Port DA (25V50-2) Controls	3-14
3.3.6 SMD 4-Port DA (25V50-4) Controls	3-15
3.3.7 High-Speed 4-Port DA (25V98-4) Controls	3-16
3.3.8 Main Memory (MM) Board Controls	3-17
3.4 SERVICE INDICATORS	3-18
3.4.1 UISIO DA (25V67) Indicator	3-18
3.4.2 Power Supply Indicators	3-19
3.4.3 Motherboard Test Point Indicators	3-20

TABLE OF CONTENTS

SECTION 4

OPERATION

	<u>Page</u>
4.1 POWER-UP AND B I T. DIAGNOSTIC PROCEDURE	4-1
4.2 POWER-DOWN PROCEDURE	4-13

SECTION 5

PREVENTIVE MAINTENANCE

	<u>Page</u>
5.1 MATERIALS REQUIRED	5-1
5.2 PM SCHEDULES	5-2
5.3 OPERATIONAL CHECK	5-3
5.4 CLEANING	5-4
5.5 INSPECTION	5-5
5.6 ADJUSTMENTS	5-6

TABLE OF CONTENTS

SECTION 6 TROUBLESHOOTING

	<u>Page</u>
6.1 TOOLS AND EQUIPMENT	6-1
6.2 POWER-UP BIT DIAGNOSTICS	6-2
6.2.1 Bus Processor BIT Diagnostics	6-3
6.2.2 Bus Processor BIT Diagnostic Options Switches	6-4
6.2.3 BP2 Class PROM-Based Power-Up BIT Error Codes	6-6
6.2.4 TC Device Adapters Power-Up BIT Diagnostics	6-23
6.2.5 UISIO Controller Power-Up BIT Diagnostics	6-26
6.3 DISKETTE-BASED DIAGNOSTICS	6-27
6.3.1 Self-Test Diagnostics	6-27
6.3.2 Diagnostic Monitor Diagnostics	6-28
6.3.3 CP7E Diagnostic Monitor Routines	6-29
6.3.4 Loading Diagnostic Monitor and Self-Test Onto IPL Drive ..	6-31
6.3.5 Running Diagnostic Monitor From Bootstrap Volume	6-33
6.3.5.1 Running Selected Monitor Diagnostics	6-38
6.3.5.2 Run-Time Menu Screen Commands and Descriptors	6-39
6.3.5.3 Interpreting the Diagnostic Monitor Error Log	6-42
6.3.6 Running Self-Test Diagnostic	6-44
6.4 ERROR CODES AND DESCRIPTIONS	6-45
6.4.1 BP2 Class Microcode Error/Status Codes and Description ..	6-45
6.4.2 BP2 Class System Error/Status Codes and Description ..	6-51
6.4.3 BP2 Class Diagnostic Monitor Error Codes and Description ..	6-52
6.4.4 Self-Test Diagnostic Execution Error Codes and Description ..	6-69
6.5 TROUBLESHOOTING FLOWCHARTS	6-89
6.5.1 Power-Up Procedure	6-89

TABLE OF CONTENTS

SECTION 7

REPAIR

	<u>Page</u>
7.1 TOOLS AND TEST EQUIPMENT	7-1
7.2 REMOVAL PROCEDURES	7-2
7.2.1 Top Cover Removal	7-2
7.2.2 Front Cover Removal	7-3
7.2.3 Side Covers Removal	7-4
7.2.4 General PCB Removal	7-5
7.2.5 Main Memory Board Removal	7-7
7.2.6 Central Processor Board Removal	7-10
7.2.7 Bus Processor Board (BP) Removal	7-11
7.2.8 SMD 2-Port Board (25V50-2) Removal	7-16
7.2.9 SMD 4-Port Board (25V50-4) Removal	7-19
7.2.10 High-Speed 4-Port Board (25V98-4) Removal	7-22
7.2.11 1-Port TC Controller (25V76-1) Removal	7-25
7.2.12 2-Port TC Controller (25V76-2) Removal	7-28
7.2.13 UISIO Controller (25V67) Removal	7-31
7.2.14 RSF Controller (25V14) Removal	7-34
7.2.15 Async Controller (25V36) Removal	7-38
7.2.16 Power Supply Removal	7-41
7.2.17 Winchester Drive Removal	7-45
7.2.18 Floppy Drive Removal	7-51
7.2.19 Keylock Assembly Removal	7-54
7.2.20 Front Panel Removal	7-55
7.2.21 TC Light Panel Removal	7-56
7.2.22 Motherboard Removal	7-57
7.2.23 Half Panel Removal	7-60
7.2.24 SCSI Interface Cable Removal	7-62
7.2.25 Dc Fan Assembly Removal	7-63

TABLE OF CONTENTS

SECTION 8 ADJUSTMENTS

	<u>Page</u>
8.1 TOOLS AND EQUIPMENT	8-1
8.1.1 Special Tools	8-1
8.2 ELECTRICAL ADJUSTMENTS	8-2
8.2.1 Power Supply Voltage Adjustments	8-2

SECTION 9 UNPACKING AND SET-UP

	<u>Page</u>
9.1 INSTALLATION SITE CHECK	9-1
9.2 TOOLS AND EQUIPMENT	9-2
9.3 UNPACKING PROCEDURES	9-3
9.3.1 Unpacking And Inspecting VS-75E Computer System	9-3
9.3.2 Unpacking Peripherals	9-5
9.3.3 Claims Information	9-6
9.3.4 Initial Set-Up	9-7

TABLE OF CONTENTS

SECTION 9

UNPACKING AND SET-UP (CONT.)

	<u>Page</u>
9.4 INSPECTION	9-8
9.4.1 VS-75E Mainframe Inspection	9-8
9.4.2 Peripheral Inspection	9-10
9.4.3 VS-75E Power Service Requirements	9-11
9.5 SWITCH SETTING	9-13
9.5.1 Line Voltage Select Switch	9-13
9.6 CONNECTIONS	9-14
9.6.1 Mainframe AC Power Connection	9-14
9.6.2 Workstation O Connection	9-15
9.7 INITIAL MAINFRAME DC VOLTAGE CHECK	9-16
9.8 SOFTWARE INSTALLATION	9-17
9.8.1 Initial Program Load (IPL)	9-17
9.8.2 System Generation (GENEDIT) Procedures	9-29
9.9 STAND-ALONE UTILITIES (SAU)	9-36
9.9.1 Copy Utility	9-37
9.9.2 Loading SAU	9-38
9.9.3 Running SAU	9-39
9.9.4 SAU Relabel Procedures	9-48
9.10 REMOTE MAINTENANCE	9-50

TABLE OF CONTENTS

SECTION 9

UNPACKING AND SET-UP (CONT.)

	<u>Page</u>
9.11 OPTION BOARD UPGRADE INSTALLATION	9-51
9.11.1 Async Option (25V36) Installation	9-52
9.11.2 1-Port TC DA Option (25V76-1) Installation	9-54
9.11.3 2-Port TC DA Option (25V76-2) Installation	9-57
9.11.4 2-Port SMD DA Option (25V50-2) Installation	9-60
9.11.5 4-Port SMD DA Option (25V50-4) Installation	9-62
9.11.6 High-Speed 4-Port SMD DA Option (25V98-4) Installation ..	9-64
9.11.7 UISIO Board Option (25V67) Installation	9-66
9.11.8 RSF Board Option (25V14) Installation	9-68
9.12 VS-75E UPGRADE KITS	9-70
9.13 VS SMALL CABLE CONCENTRATOR	9-71
9.14 LATEST PCB REVISIONS	9-72

SECTION 10

FUNCTIONAL DESCRIPTION

	<u>Page</u>
10.1 INTRODUCTION	10-1
10.2 VS-75E COMPUTER SYSTEM ARCHITECTURE	10-2

TABLE OF CONTENTS

SECTION 10

FUNCTIONAL DESCRIPTION (CONT.)

	<u>Page</u>
10.3 SYSTEM BLOCK DIAGRAM DESCRIPTION	10-4
10.3.1 System Bus Structure	10-5
10.3.2 Bus Processor Description	10-6
10.3.3 Central Processor Unit (CPU) Description	10-11
10.3.4 Main Memory Description	10-12
10.3.5 Front Panel Description	10-13
10.3.6 Motherboard Description	10-14
10.3.7 Switching Power Supply Description	10-15
10.4 SYSTEM OPTIONAL CONTROLLER BOARDS	10-16

SECTION 11

SPECIFICATIONS

	<u>Page</u>
11.1 HARDWARE	11-1
11.1.1 VS-75E Mainframe	11-1
11.1.2 145MB Winchester Drive Specifications	11-2
11.1.3 SPS714 Switching Power Supply Specifications	11-3
11.1.4 1.2MB Floppy Drive Specifications	11-4
11.2 SOFTWARE SPECIFICATIONS	11-5
11.2.1 VS-75E Minimum Operating System Software	11-5

TABLE OF CONTENTS

SECTION 11 SPECIFICATIONS (CONT.)

	<u>Page</u>
11.3 DIAGNOSTICS SPECIFICATIONS	11-6
11.3.1 Built-In-Test (BIT)	11-6
11.3.2 Diagnostics	11-7

SECTION 12 ILLUSTRATED PARTS

	<u>Page</u>
12.1 MAJOR ASSEMBLIES	12-1
12.2 SUBASSEMBLIES	12-2
12.2.1 VS-75E Computer System Covers	12-2
12.2.2 VS-75E Computer Chassis	12-4
12.2.3 VS-75E Computer Card Cage	12-6
12.2.4 VS-75E Rear Panel Assembly	12-8
12.3 VS-75E INTERCONNECT DIAGRAM	12-10
12.4 CABLE ASSEMBLIES	12-12
12.4.1 Standard Cable Assemblies	12-12
12.4.2 Optional Cable Assemblies	12-13

SECTION 1
INTRODUCTION

SECTION 1 CONTENTS

SECTION 1 INTRODUCTION

	<u>Page</u>
1.1 SCOPE AND PURPOSE	1-1
1.2 ORGANIZATION AND LAYOUT	1-2
1.3 ABBREVIATIONS AND SYMBOLS USED IN THIS MANUAL	1-3

1.1 Scope and Purpose

This manual contains installation, operation, troubleshooting, and repair information for the VS-75E Computer System, a full function VS system with multi-user DP and WP capabilities. This manual also contains a functional description of the VS-75E and an illustrated breakdown of replaceable parts.

The purpose of the manual is to provide Customer Engineering personnel with the information necessary to install, troubleshoot, and repair any model of the VS-75E in the field. Familiarity with small VS systems is recommended for the effective use of this manual.

● END

1.2 Organization and Layout

This manual is divided into 12 sections numbered 1 through 12. Each section describes a separate maintenance subject and is arranged to minimize references to other sections. Referencing to other frames is made by means of an arrow (➡) followed by the section number(s) being referenced.

All or most information pertaining to a specific task is located on a single and/or double frame. Each frame contains illustrations, numbered steps, and/or text describing the individual steps required to accomplish each task. The steps within a frame are numbered in sequence in a clockwise direction around the various illustrations. Each section is preceded by the section number and a section table of contents. The sections and corresponding frames are arranged in numerical sequence from left-to-right and from top-to-bottom on the individual fiche cards.

◆ END

INTRODUCTION

1.3 Abbreviations And Symbols Used In This Manual (Sheet 1 of 3)

<i>Abbreviation/Symbol</i>	<i>Definition</i>
AC	Alternating Current
ANSI	American National Standards Institute
APA	Active Port Assembly
ASSY	Assembly
BIT	Built In Test
BP	Bus Processor
BPI	Bits Per Inch
CBL	Cable
CC	Cable Concentrator
CM	Control Mode
CMD	Cartridge Module Drive
CP	Central Processor
CPU	Central Processing Unit
DA	Device Adapter
DC	Direct Current
DIP	Dual In-line Package
DOS	Disk Operating System
DRAM	Data Random Access Memory
DVM	Digital Voltmeter
EAPA	Electrically Active Port Assembly
ECC	Error Correction Code
EIA	Electronic Industries Association
FCC	Federal Communications Commission

◆NEXT

INTRODUCTION

1.3 Abbreviations And Symbols Used In This Manual (Sheet 2 of 3)

<i>Abbreviation/Symbol</i>	<i>Definition</i>
FMD	Fixed Module Drive
FRU	Field-Replaceable Unit
HD-APA	High Density APA
HEX	Hexidecimal Notation (H)
HSDC	High-Speed Disk Controller
I/O	Input/Output
IPB	Illustrated Parts Breakdown
IPL	Initial Program Load
KG	Kilogram
LED	Light-Emitting Diode
M	Mega, (Million)
MBPS	Megabits Per Second
MM	Main Memory
MODEM	Modulator/Demodulator
NEMA	National Electrical Manufacturers Association
OS	Operating System
PARA	Paragraph
P-BAND	Peripheral Band
P/N	Part Number
PCA	Printed Circuit Assembly
PDA	Physical Device Address

➡NEXT

1.3 Abbreviations And Symbols Used In This Manual (Sheet 3 of 3)

INTRODUCTION

<i>Abbreviation/Symbol</i>	<i>Definition</i>
PF	Program Function
PM	Preventive Maintenance
RAM	Random Access Memory
RF	Radio Frequency
RSD	Removable Storage Drive
SCSI	Small Computer System Interface
SMD	Storage Module Drive
SPS	Switching Power Supply
SOC	Socket
SW	Switch
SYSGEN	System Generation
TAC	Technical Assistance Center
TC	Telecommunications
TP	Test Point
V	Volts
VS	Virtual Storage
VTOC	Volume Table of Contents
WS	Workstation
WLI P/N	Wang Laboratories, Inc. Part Number

● END

SECTION

2

IDENTIFICATION

SECTION 2 CONTENTS

SECTION 2 IDENTIFICATION

	<u>Page</u>
2.1 MAJOR ASSEMBLIES	2-1
2.1.1 System Components	2-1
2.2 VS-75E COMPUTER MAJOR PARTS (FRONT VIEW)	2-2
2.3 VS-75E MAJOR PARTS (REAR VIEW)	2-3

2.1 Major Assemblies

2.1.1 System Components

VS-75E
COMPUTER SYSTEM

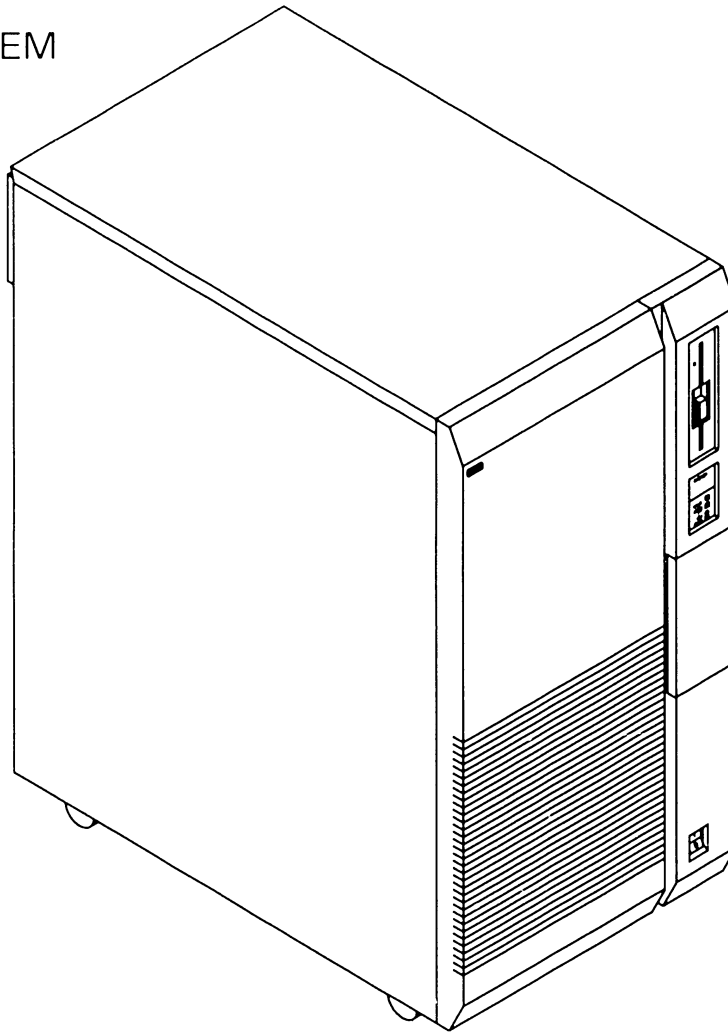

● END

2.2 VS-75E Computer Major Parts (Front View)

IDENTIFICATION

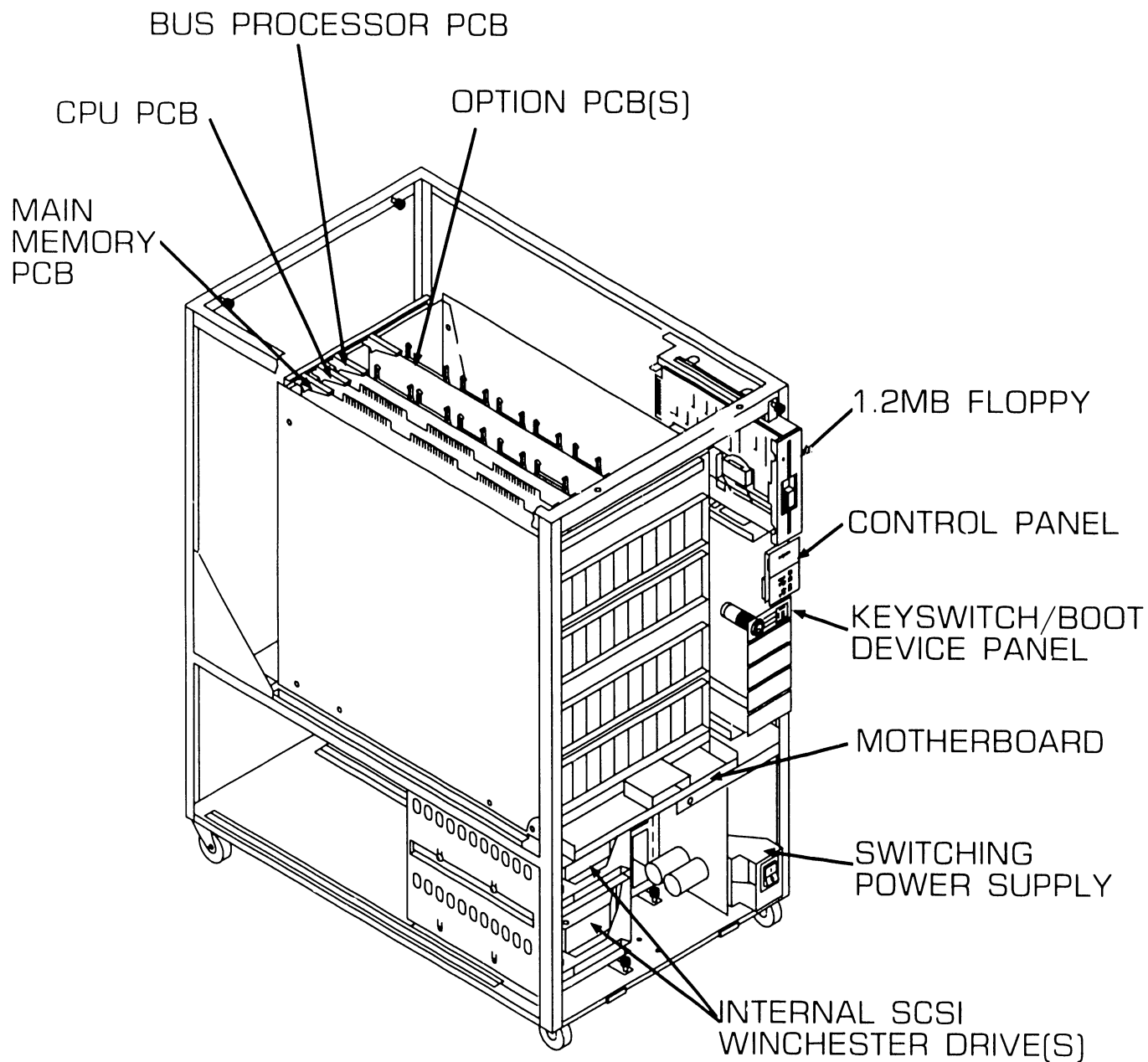

● END

2.3 VS-75E Computer Major Parts (Rear View)

IDENTIFICATION

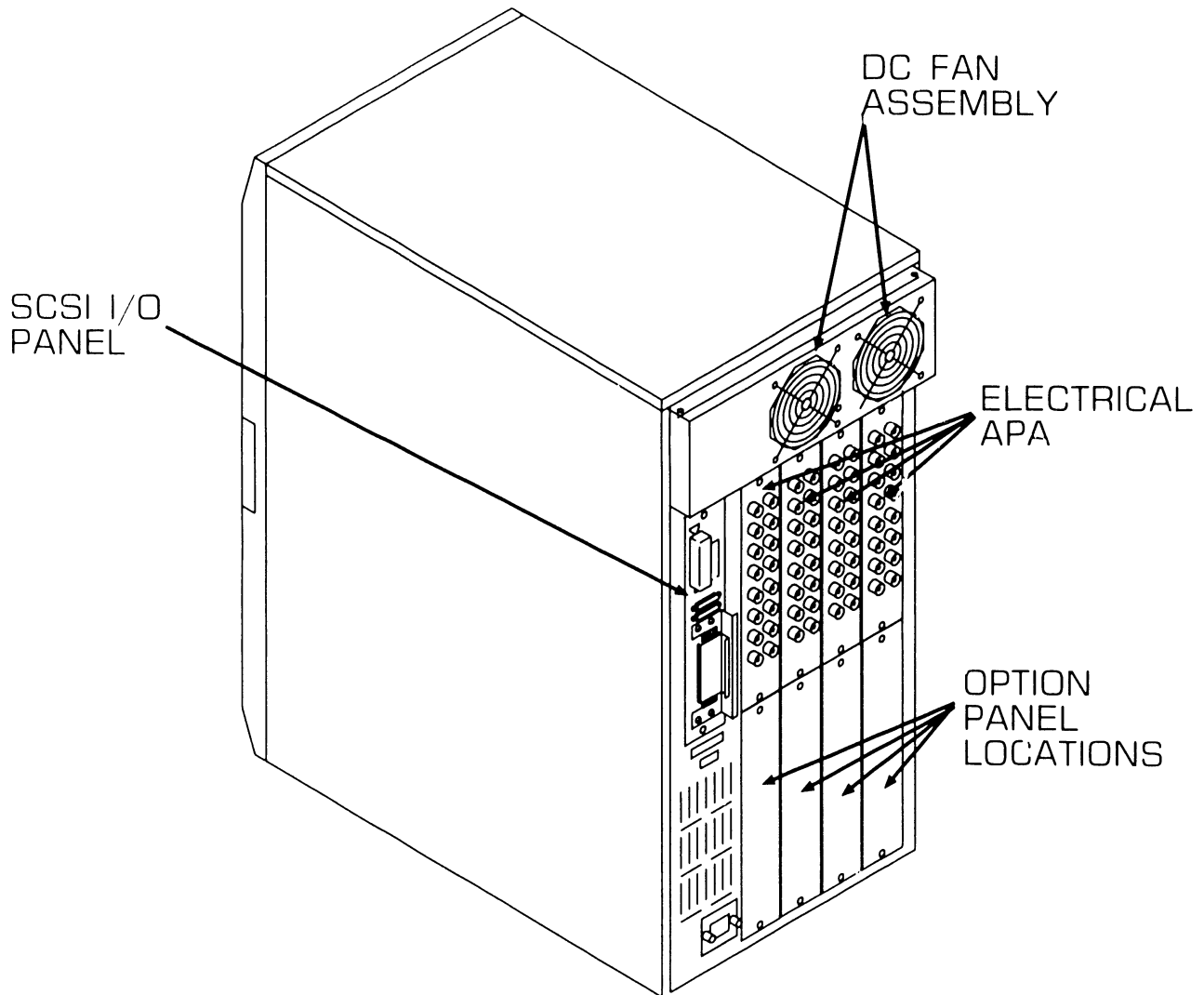

● END

SECTION

3

**CONTROLS AND
INDICATORS**

SECTION 3 CONTENTS

SECTION 3 CONTROLS AND INDICATORS

	<u>Page</u>
3.1 OPERATOR CONTROLS	3-1
3.1.1 Front Panel Controls	3-1
3.1.2 TC Front Panel Controls (Optional)	3-3
3.2 OPERATOR INDICATORS	3-5
3.2.1 Front Panel Indicators	3-5
3.2.2 TC Front Panel Indicators (Optional)	3-7
3.3 SERVICE CONTROLS	3-8
3.3.1 Power Supply Controls (2 sheets)	3-8
3.3.2 1-Port TC DA (25V76-1) Controls	3-11
3.3.3 2-Port TC DA (25V76-2) Controls	3-12
3.3.4 Bus Processor (BP) Controls	3-13
3.3.5 SMD 2-Port DA (25V50-2) Controls	3-14
3.3.6 SMD 4-Port DA (25V50-4) Controls	3-15
3.3.7 High-Speed 4-Port DA (25V98-4) Controls	3-16
3.3.8 Main Memory (MM) Board Controls	3-17
3.4 SERVICE INDICATORS	3-18
3.4.1 UISIO DA (25V67) Indicator	3-18
3.4.2 Power Supply Indicators	3-19
3.4.3 Motherboard Test Point Indicators	3-20

3.1 CONTROLS AND INDICATORS

3.1.1 Operator Controls

3.1.1 Front Panel Controls (sheet 1 of 3)

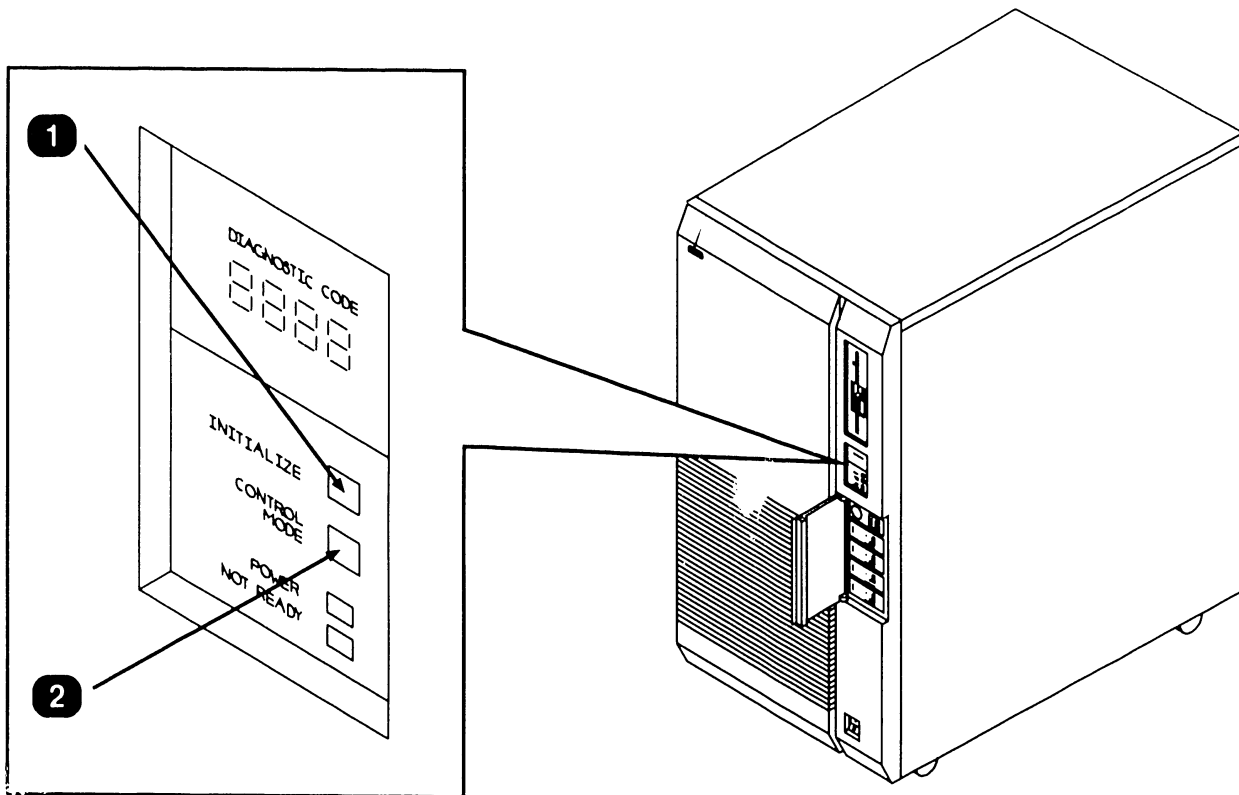

<i>Item</i>	<i>Name</i>	<i>Type and Function</i>
1	Initialize Switch	Recessed pushbutton switch; red, pressing switch IPLs system and resets system clock.
2	Control Mode Switch	Recessed pushbutton switch; green, pressing switch during power-on allows verification of HEX display by looping on decrement mode. Pressing switch any other time forces CP into Control Mode if control mode micro-code is loaded.

►NEXT

3.1 CONTROLS AND INDICATORS

3.1.1 Operator Controls

3.1.1 Front Panel Controls (sheet 2 of 3)

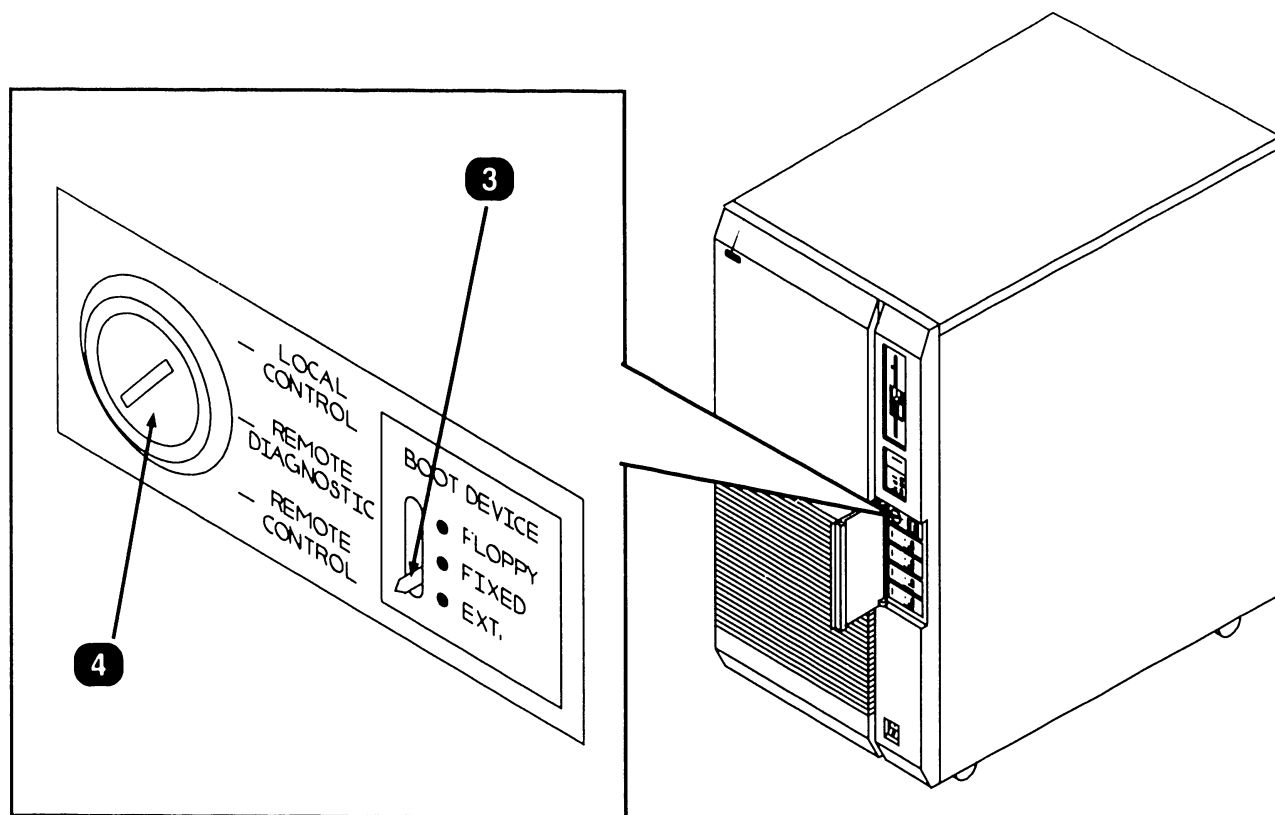

Item	Name	Type and Function
3	Boot Device Switch	Three-position toggle; Boot Device selection switch enables the operator to select the disk drive used for diagnostics or IPL.
4	Local/Remote Switch	Three position key switch; local control allows normal operation. Remote control allows connection for remote maintenance. Remote Diagnostics is not used.

▶NEXT

3.1 CONTROLS AND INDICATORS

3.1.1 Operator Controls

3.1.1 Front Panel Controls (sheet 3 of 3)

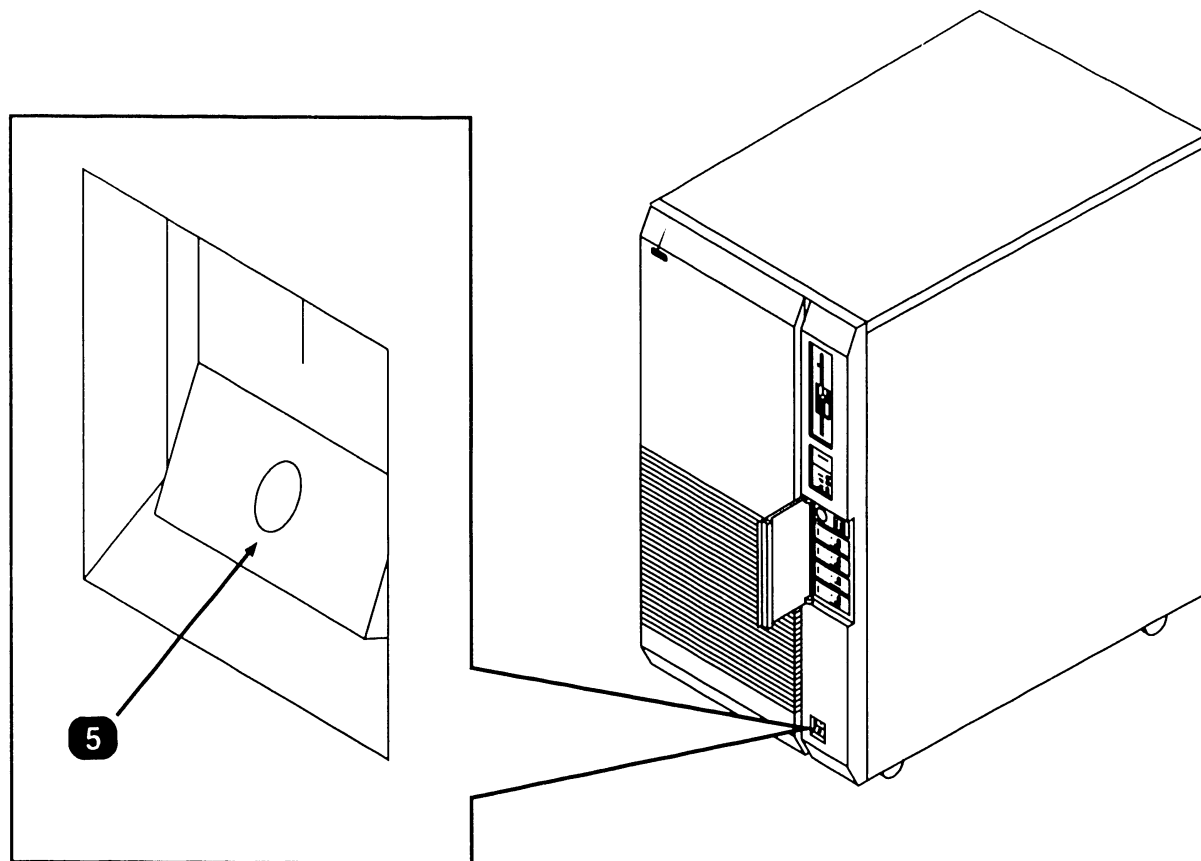

<i>Item</i>	<i>Name</i>	<i>Type and Function</i>
5	AC Power-On Switch	Pushbutton switch; pressing switch to '1' position provides AC power to power supply. Pressing switch to '0' position removes AC power from power supply.

● END

3.1 CONTROLS AND INDICATORS

3.1.1 Operator Controls

3.1.2 TC Front Panel Controls (Optional)

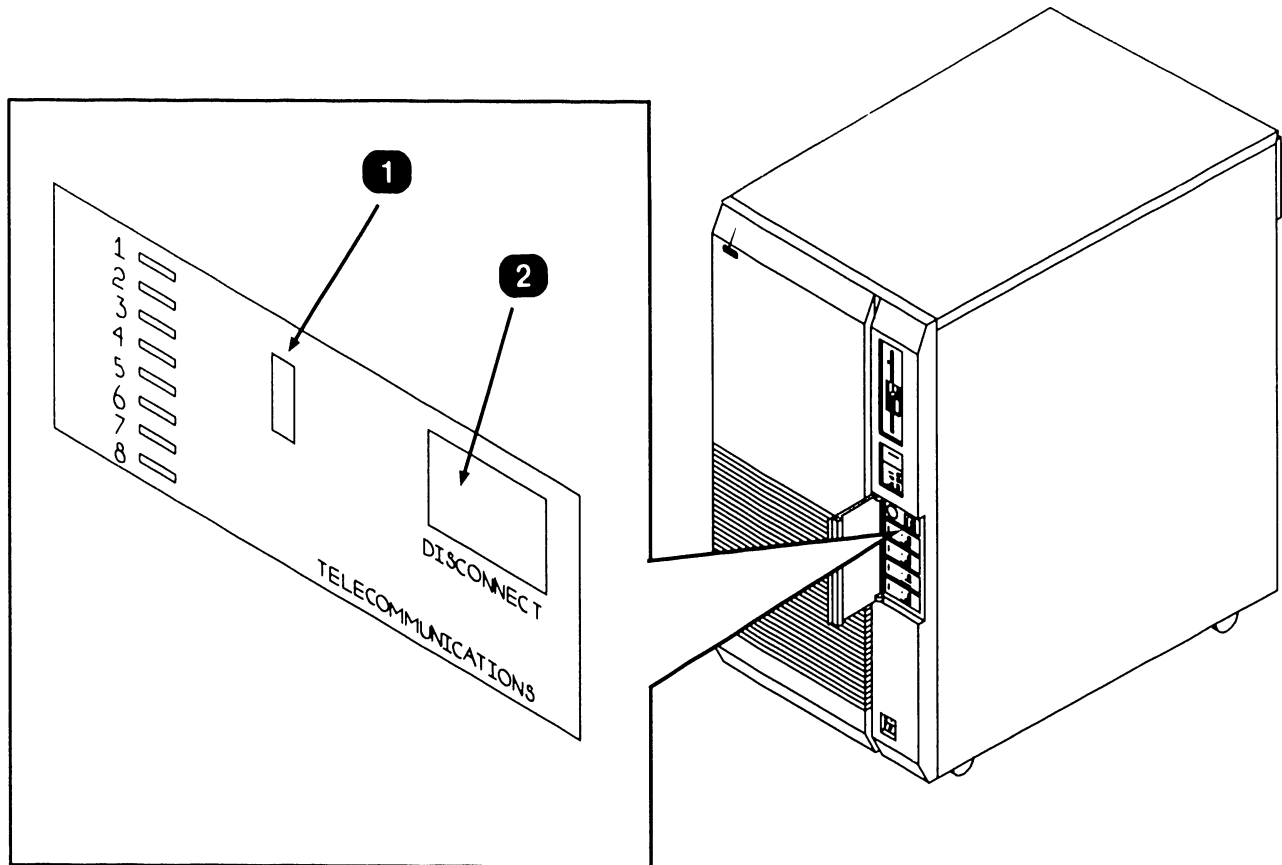

<i>Item</i>	<i>Name</i>	<i>Type and Function</i>
1	Clear Switch	Recessed pushbutton switch; when pressed generates a TC DA power-up reset state.
2	TC Disconnect	Recessed pushbutton switch; when pressed clears TC DA Data Terminal Ready signal.

● END

3.2 CONTROLS AND INDICATORS

3.2 Operator Indicators

3.2.1 Front Panel Indicators (Sheet 1 of 2)

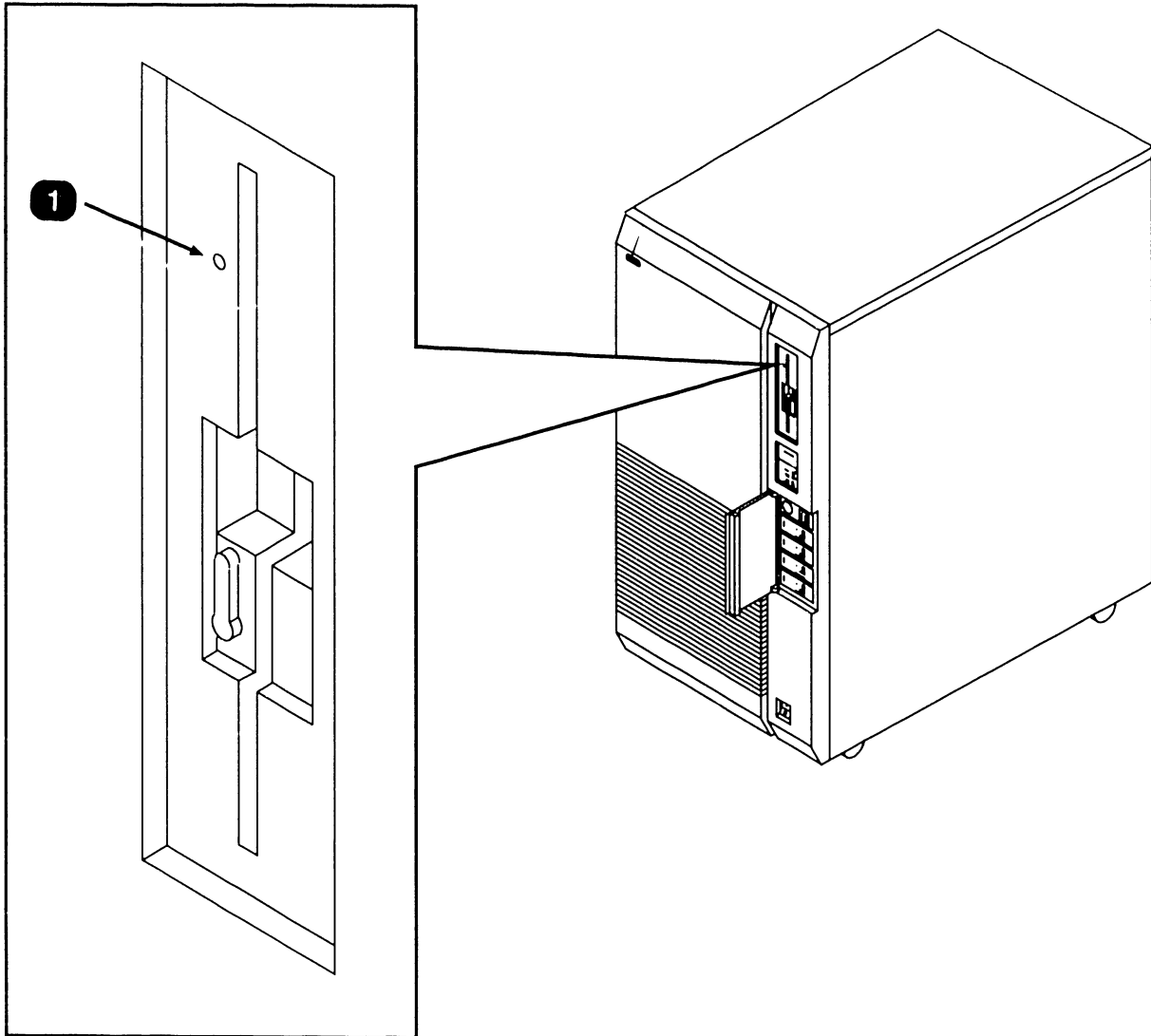

<i>Item</i>	<i>Name</i>	<i>Type and Function</i>
1	Diskette Drive Activity LED	LED; amber LED denotes 1.2M drive; red LED denotes 360K drive, illuminates to indicate activity on diskette drive.

➡NEXT

3.2 CONTROLS AND INDICATORS

3.2 Operator Indicators

3.2.1 Front Panel Indicators (Sheet 2 of 2)

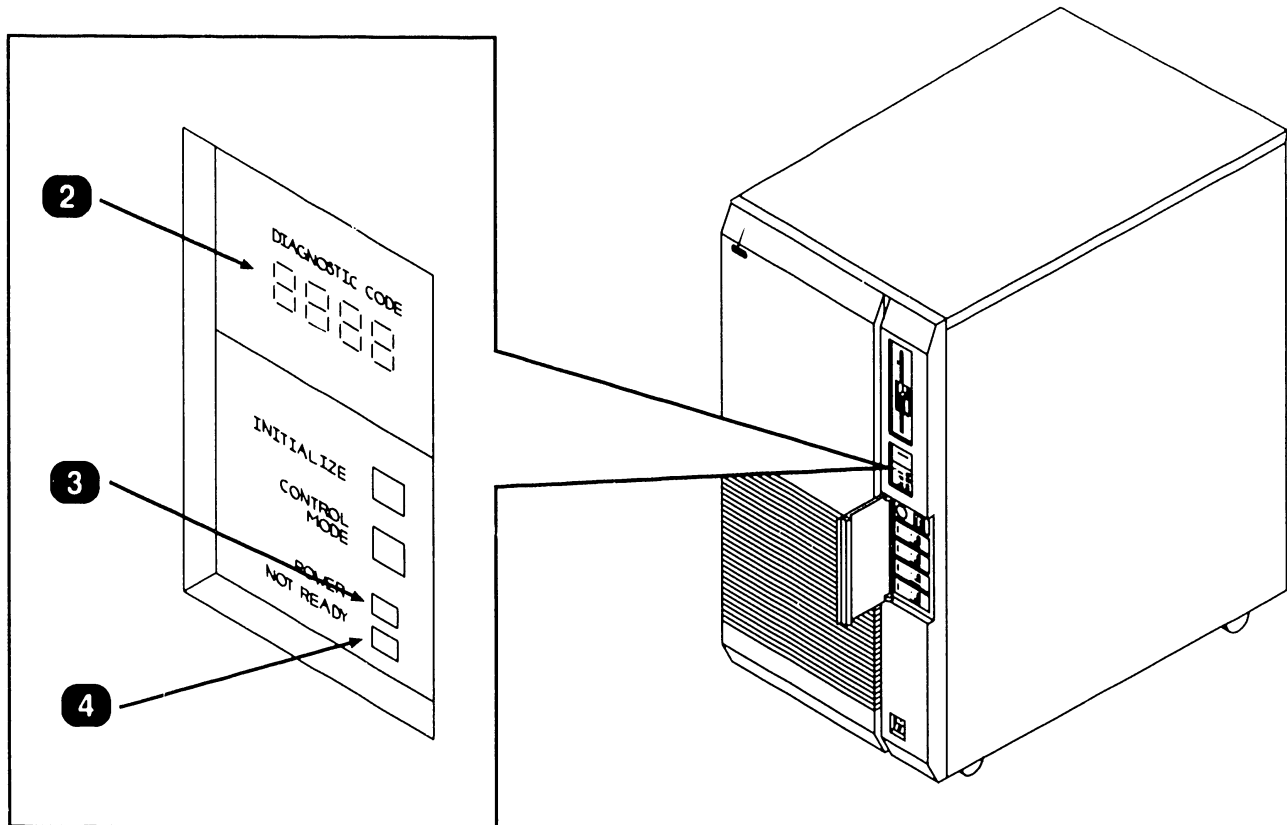

Item	Name	Type and Function
2	Diagnostics LEDs	HEX LEDs; displays BIT power-up diagnostics being executed and self-test monitor error codes. If an error occurs, the error code will be continuously displayed.
3	DC Power LED	LED; green, illuminates to indicate DC power on.
4	Not Ready LED	LED; red, illuminates during power-up diagnostics mode, off during normal operation.

● END

3.2 CONTROLS AND INDICATORS

3.2 Operator Indicators

3.2.2 TC Front Panel Indicators (Optional)

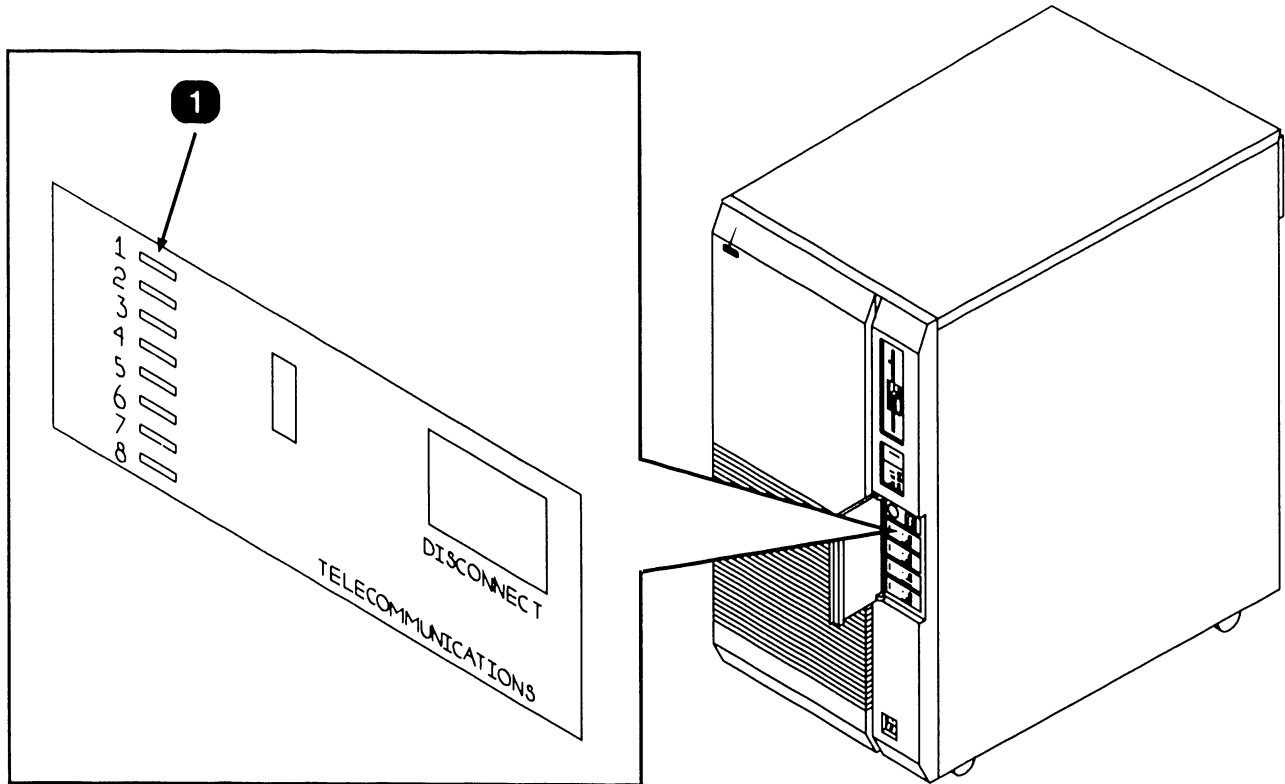

Item	Name	Type and Function
1	TC Activity LEDs	Eight LEDs; red, displays power-up BIT test activity/error codes and during normal operation displays TC protocol status (►6.2.4, 7.2.21)

● END

3.3 CONTROLS AND INDICATORS

3.3 Service Controls

3.3.1 Power Supply Controls (Sheet 1 of 3)

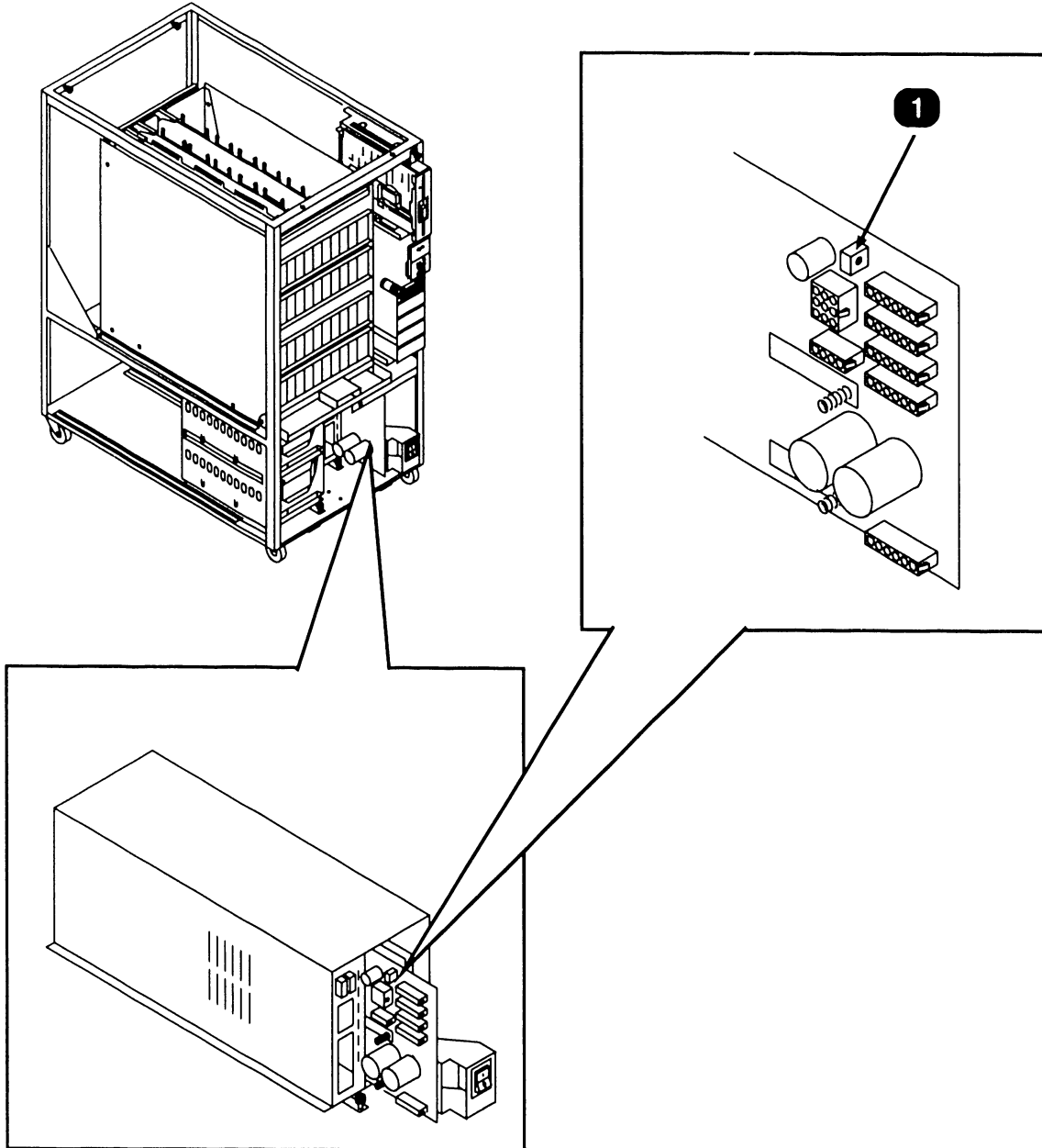

<i>Item</i>	<i>Name</i>	<i>Type and Function</i>
1	R1 +5V Adjust	Potentiometer; adjusts +5 Vdc.

►NEXT

3.3 CONTROLS AND INDICATORS

3.3 Service Controls

3.3.1 Power Supply Controls (Sheet 2 of 3)

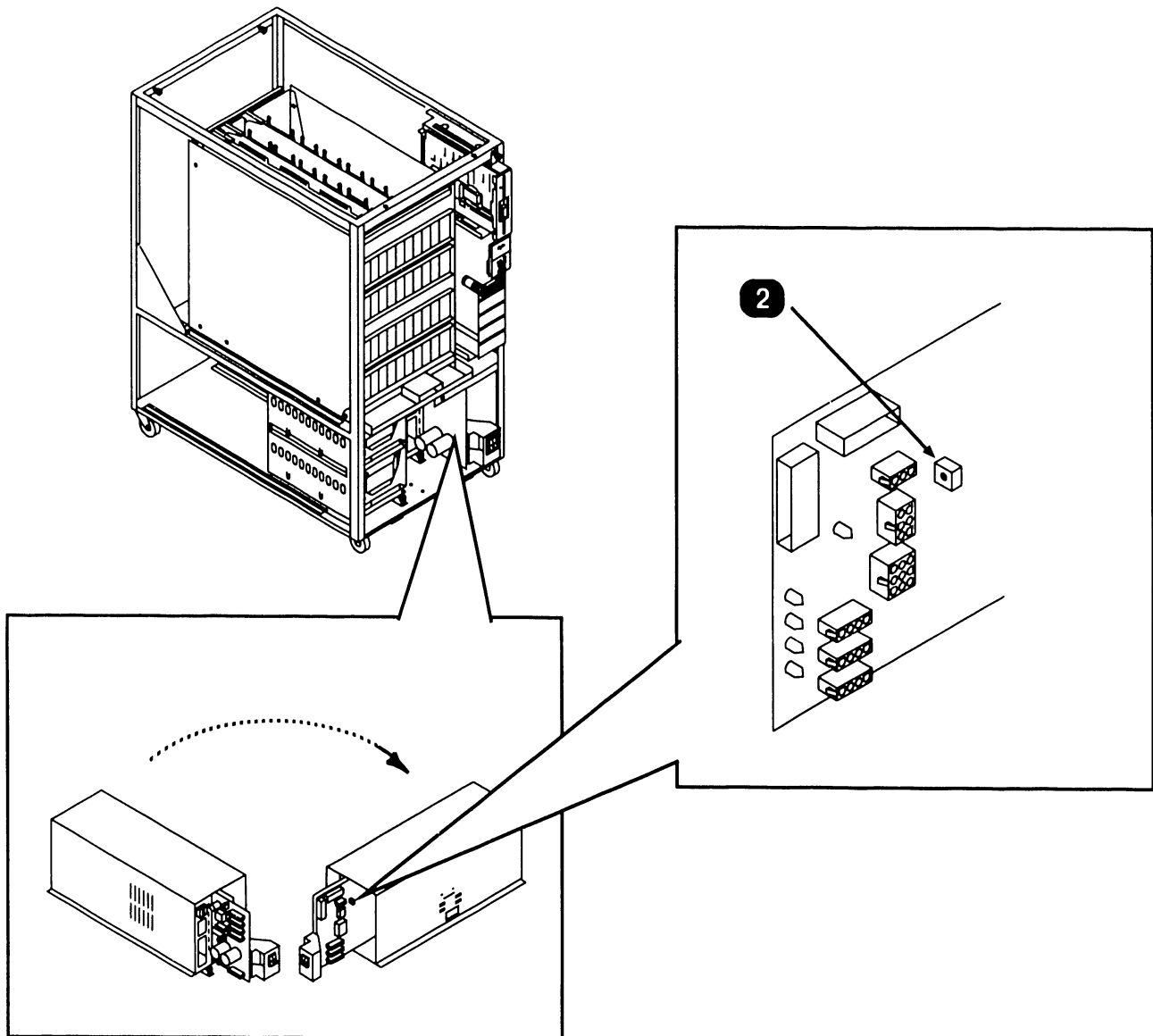

<i>Item</i>	<i>Name</i>	<i>Type and Function</i>
2	R28 +12/24V Adjust	Potentiometer; adjusts +12 and +24 Vdc.

◆NEXT

3.3 CONTROLS AND INDICATORS

3.3 Service Controls

3.3.1 Power Supply Controls (Sheet 3 of 3)

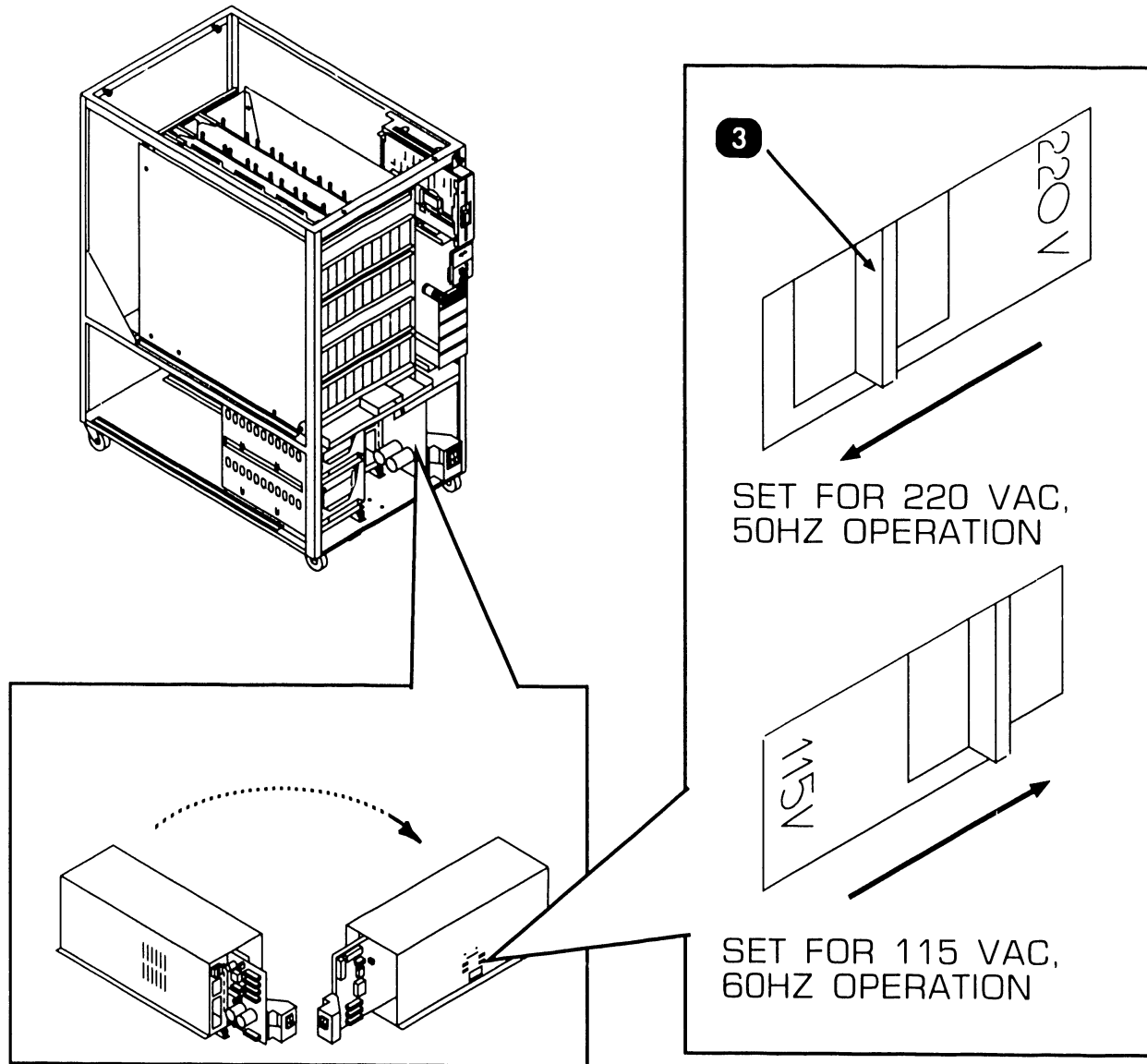

<i>Item</i>	<i>Name</i>	<i>Type and Function</i>
3	Voltage Select Switch	Slider-type switch; selects ac operating voltage of 115V or 220V, determined by available line voltage.

● END

3.3 CONTROLS AND INDICATORS

3.3 Service Controls

3.3.2 1-Port TC DA (25V76-1) Controls

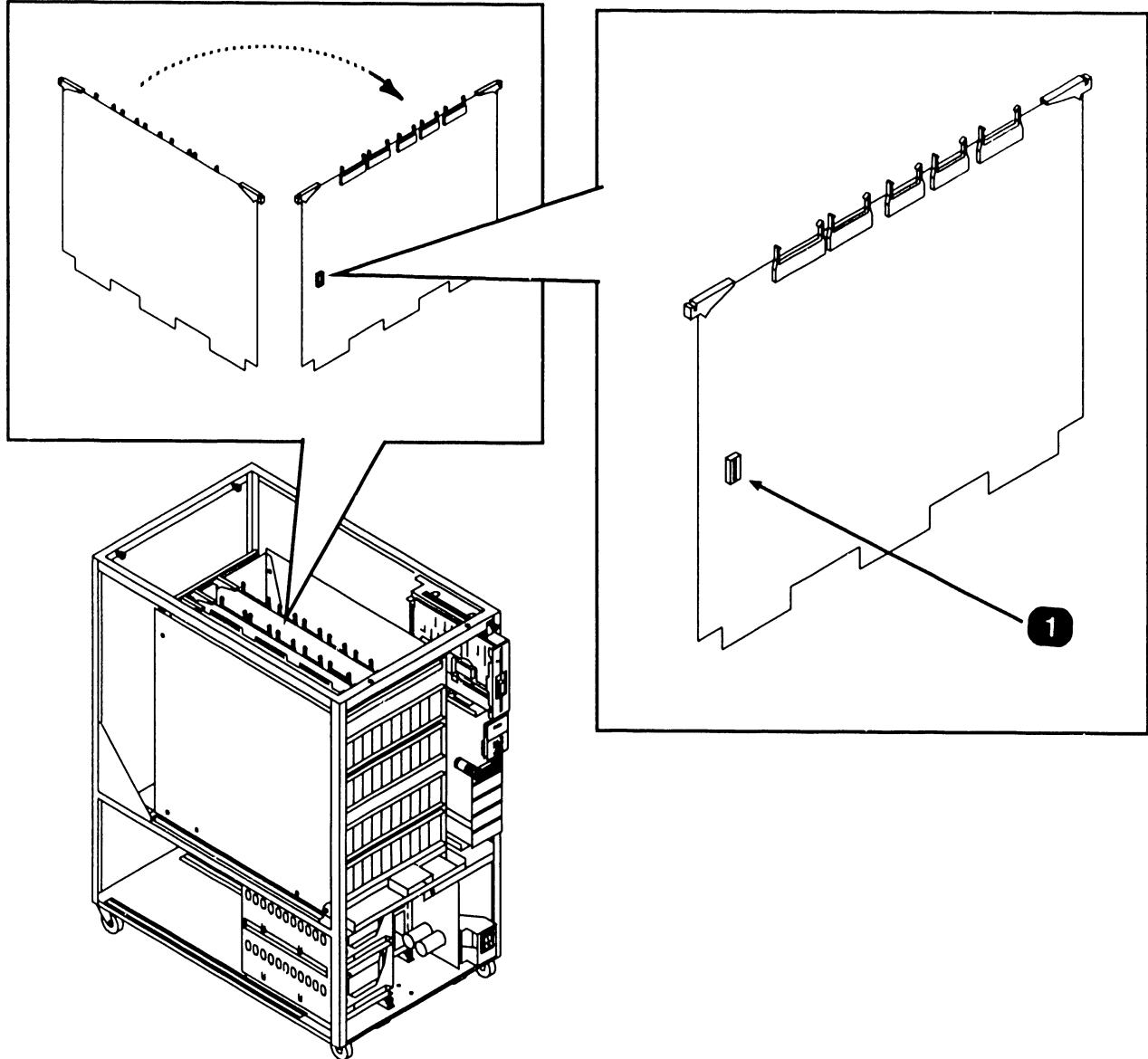

<i>Item</i>	<i>Name</i>	<i>Type and Function</i>
1	Telecommunications Mode Select Switch SW1	Rocker-type 8-bit switch bank; selects various diagnostic tests and X.21 support. (►6.2.4, 7.2.11)

● END

3.3 CONTROLS AND INDICATORS

3.3 Service Controls

3.3.3 2-Port TC DA (25V76-2) Controls

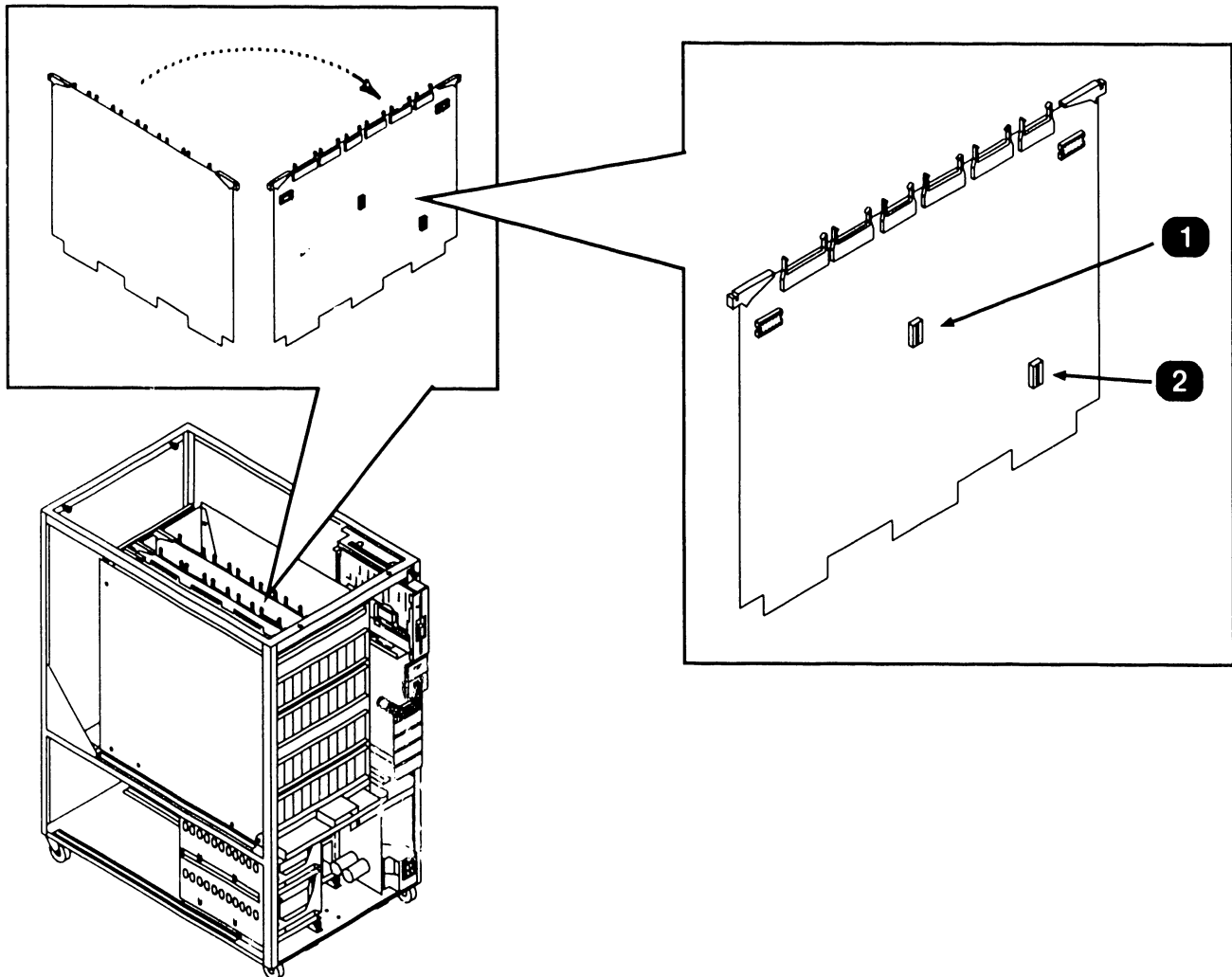

<i>Item</i>	<i>Name</i>	<i>Type and Function</i>
1	Telecommunications Mode Select Switch SW1	Rocker-type 8-bit switch bank; selects various diagnostic tests and X.21 support for channel 1. (►6.2.4, 7.2.12)
2	Telecommunications Mode Select Switch SW2	Rocker-type 8-bit switch bank; selects various diagnostic tests and X.21 support for channel 2. (►6.2.4, 7.2.12)

● END

3.3 CONTROLS AND INDICATORS

3.3 Service Controls

3.3.4 Bus Processor (BP) Controls

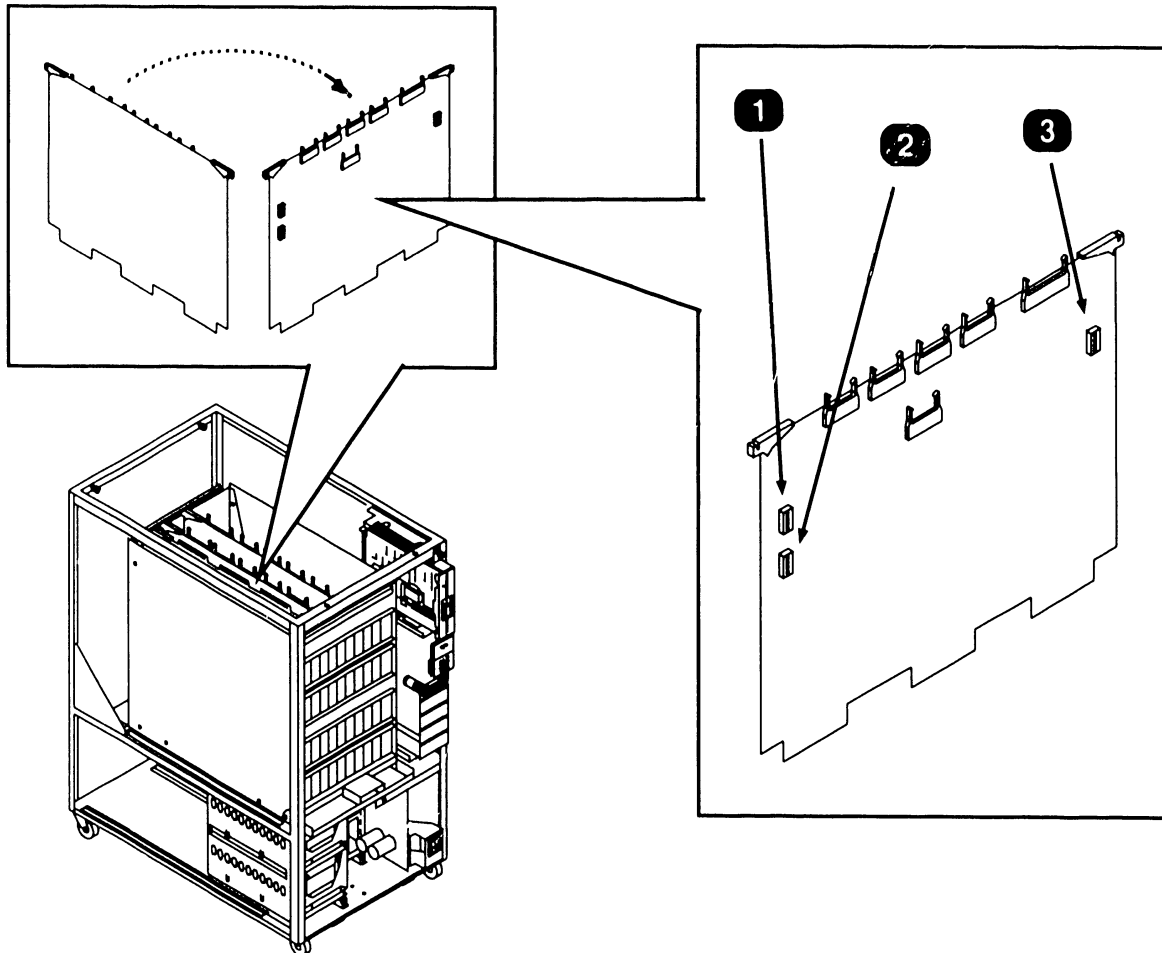

Item	Name	Type and Function
1	Drive-type/SCSI Device ID Select Switch SW1	Rocker-type 8-bit switch bank; selects diskette Drive-type and SCSI Device ID. (►7.2.7)
2	WSO Location/Control Mode Select Switch SW2	Rocker-type 8-bit switch bank; selects various IPL Control and BIT test. (►6.2.2, 7.2.7)
3	Wait State Control Switch SW3	Rocker-type 8-bit switch bank; selects BP Wait states. (►7.2.7)

● END

3.3 CONTROLS AND INDICATORS

3.3 Service Controls

3.3.5 SMD 2-Port DA (25V50-2) Controls

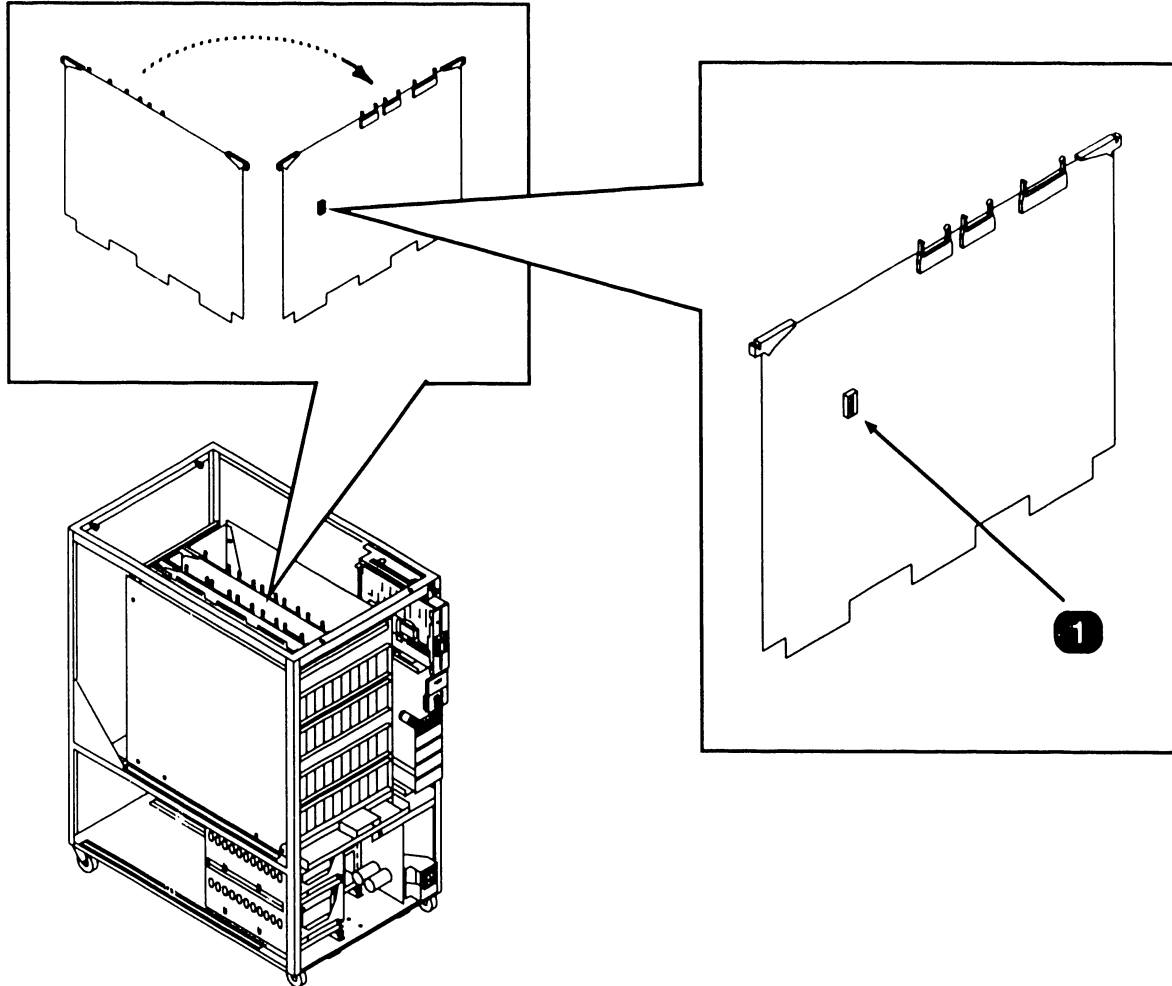

<i>Item</i>	<i>Name</i>	<i>Type and Function</i>
1	Drive-type/Port Select Switch SW1	Rocker-type 8-bit switch bank; selects external Drive-type for one of two ports. Switches Sw1-Sw4 select Drive 1 (port 1). Switches Sw5-Sw8 select Drive 0 (port 0). (►7.2.8)

◆ END

3.3 CONTROLS AND INDICATORS

3.3 Service Controls

3.3.6 SMD 4-Port DA (25V50-4) Controls

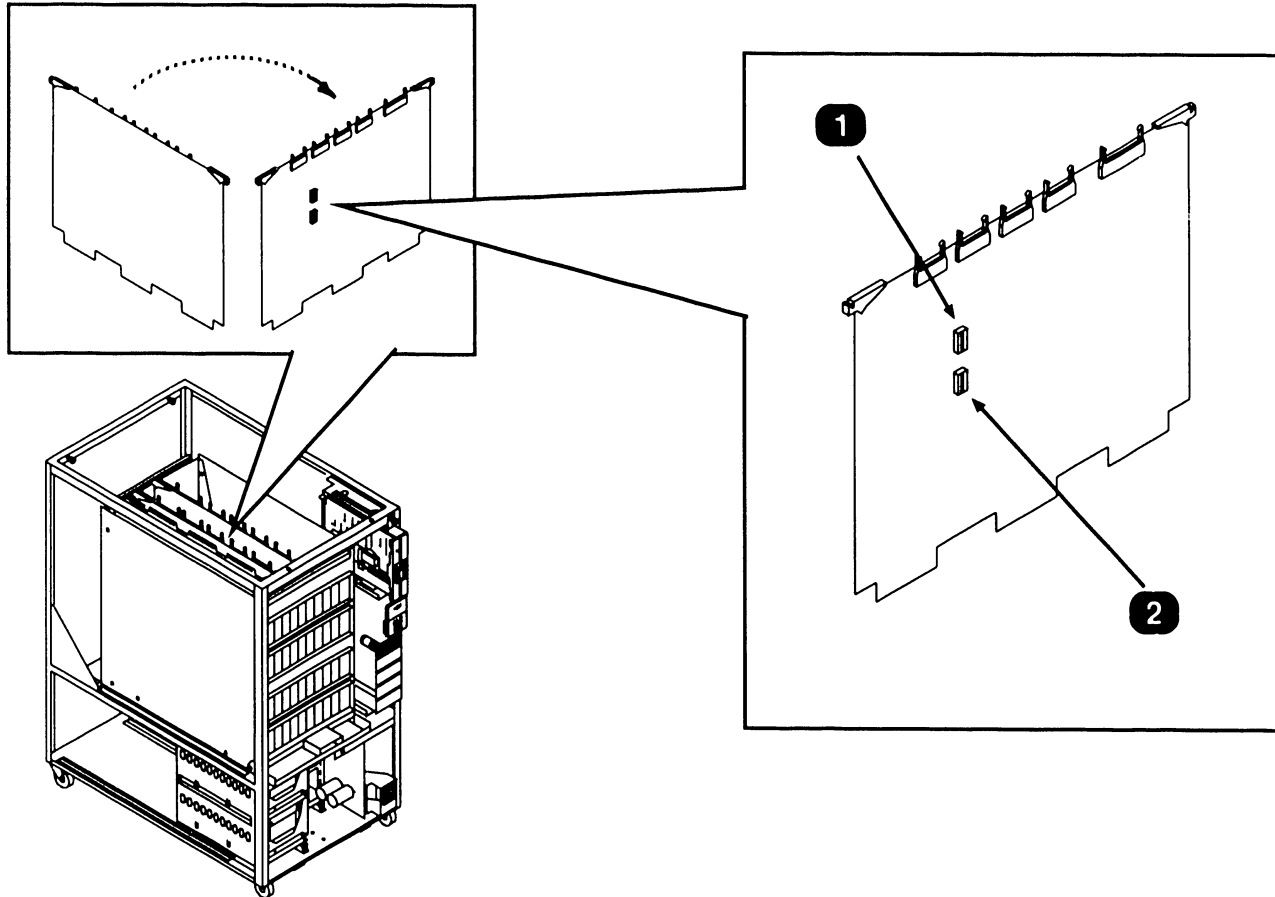

<i>Item</i>	<i>Name</i>	<i>Type and Function</i>
1	Drive-type/Port Select Switch SW1	Rocker-type 8-bit switch bank; selects external Drive-type for one of two ports. Switches Sw1-Sw4 select Drive 1 (port 1). Switches Sw5-Sw8 select Drive 0 (port 0). [▶7.2.9]
2	Drive-type/Port Select Switch SW2	Rocker-type 8-bit switch bank; selects external Drive-type for one of two ports. Switches Sw1-Sw4 select Drive 3 (port 3). Switches Sw5-Sw8 select Drive 2 (port 2). [▶7.2.9]

● END

3.3 CONTROLS AND INDICATORS

3.3 Service Controls

3.3.7 High-Speed SMD 4-Port DA (25V98-4) Controls

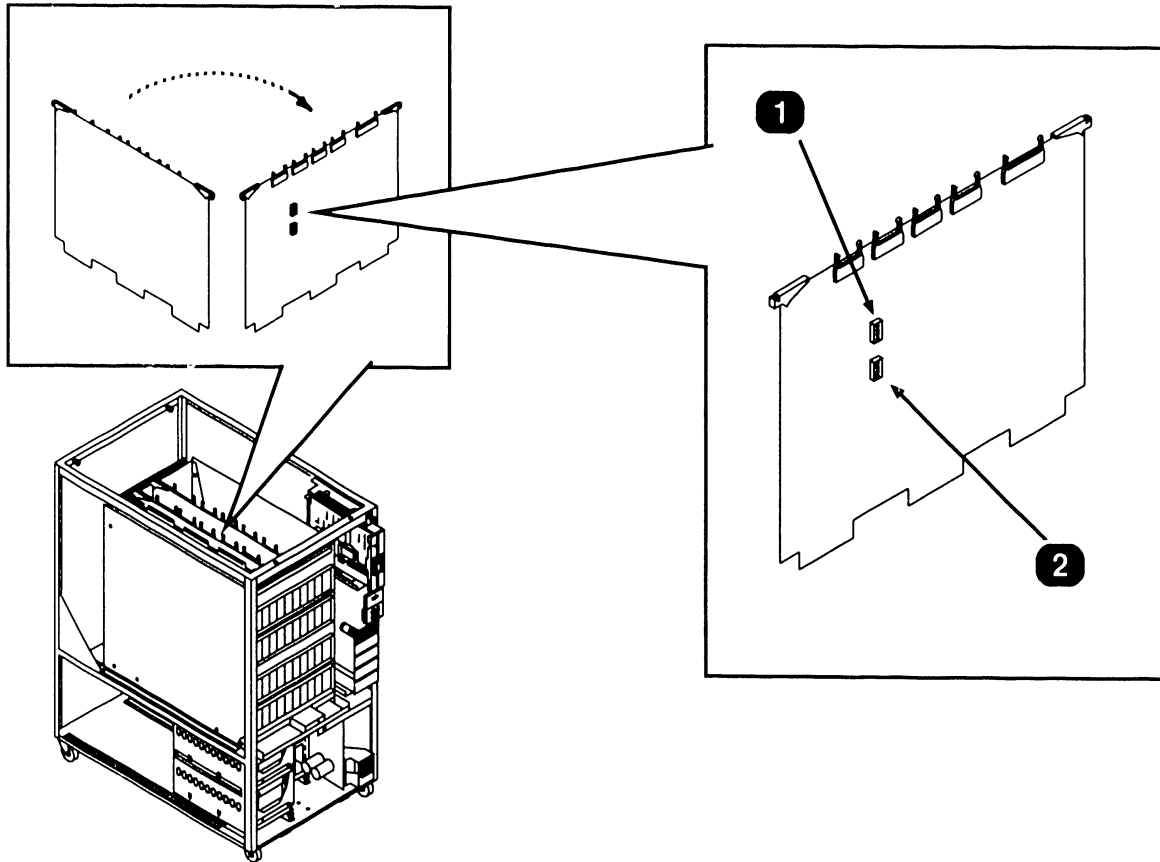

<i>Item</i>	<i>Name</i>	<i>Type and Function</i>
1	Drive-type/Port Select Switch SW1	Rocker-type 8-bit switch bank; selects external Drive-type for one of two ports. Switches Sw1-Sw4 select Drive 1 (port 1). Switches Sw5-Sw8 select Drive 0 (port 0). (➡7.2.10)
2	Drive-type/Port Select Switch SW2	Rocker-type 8-bit switch bank; selects external Drive-type for one of two ports. Switches Sw1-Sw4 select Drive 3 (port 3). Switches Sw5-Sw8 select Drive 2 (port 2). (➡7.2.10)

● END

3.3 CONTROLS AND INDICATORS

3.3 Service Controls

3.3.8 Main Memory (MM) Board Controls

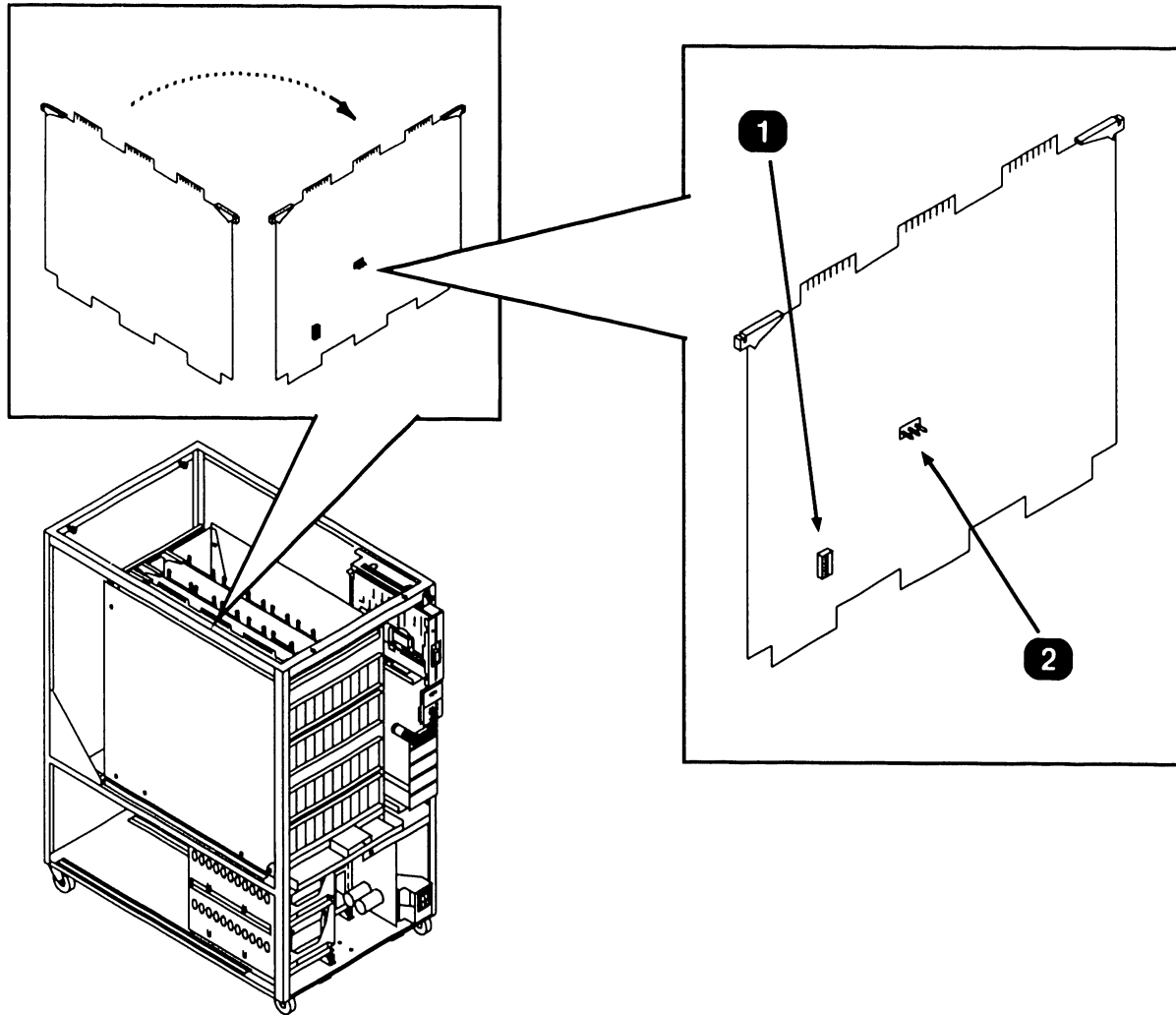

<i>Item</i>	<i>Name</i>	<i>Type and Function</i>
1	Memory Size Select Switch SW1	Rocker-type 8-bit switch bank; selects on-board memory size in relation to JP1 setting. (►7.2.5)
2	Memory Module Size Jumper JP1	3-Pin Jumper; defines SIMM device type used for memory storage modules installed.

● END

3.4 CONTROLS AND INDICATORS

3.4 Service Indicators

3.4.1 UISIO DA (25V67) Indicator

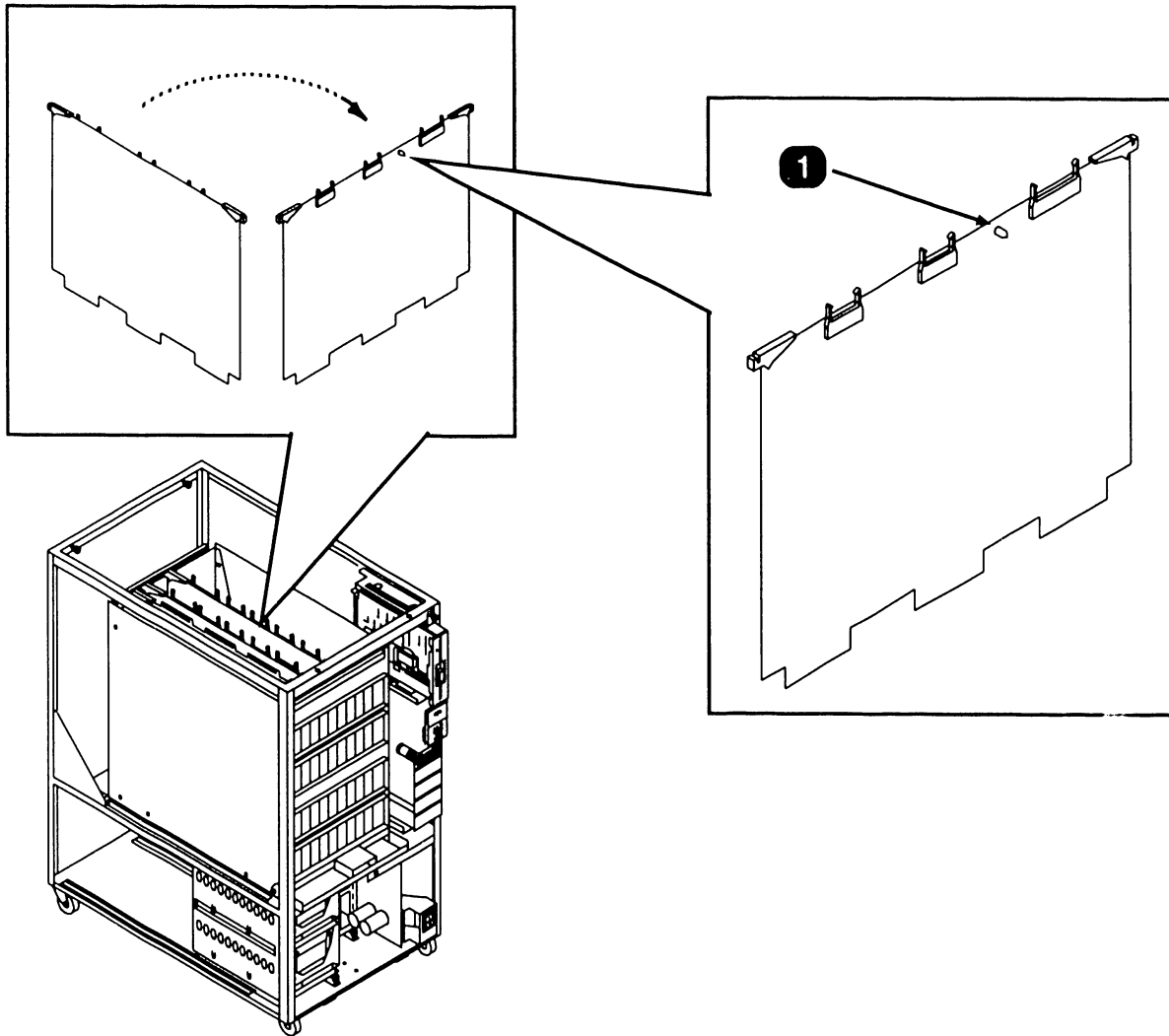

<i>Item</i>	<i>Name</i>	<i>Type and Function</i>
1	Diagnostic LED	LED; red, illuminates when UISIO DA power-up BIT test are run. If LED remains lit, UISIO DA BIT failure has occurred. (►6.2.5)

● END

3.4 CONTROLS AND INDICATORS

3.4 Service Indicators

3.4.2 Power Supply Indicators

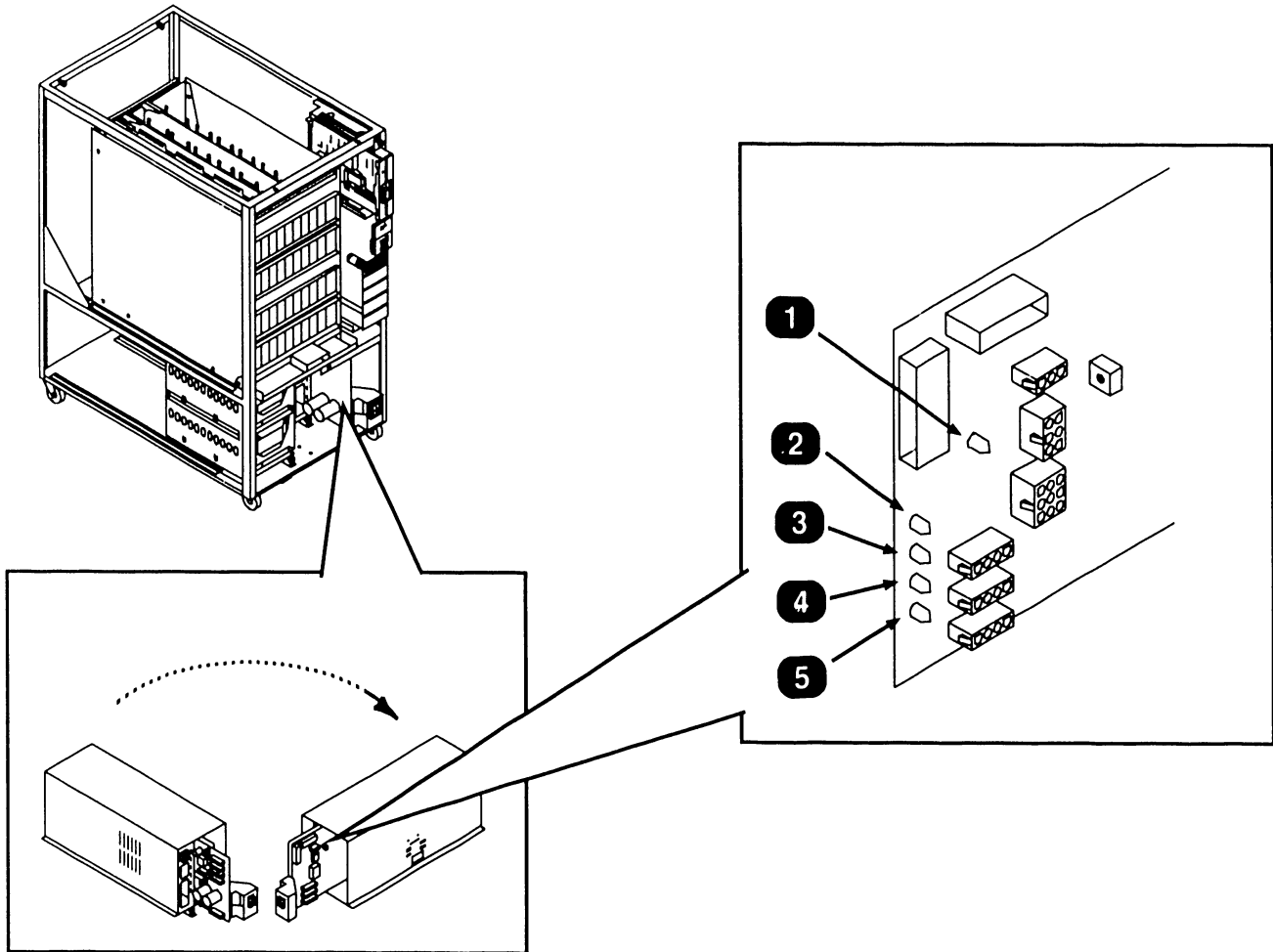

Item	Name	Type and Function
1	LED 5	LED; amber, indicates -5 Vdc is present.
2	LED 4	LED; amber, indicates +5 Vdc is present.
3	LED 3	LED; amber, indicates -12 Vdc is present.
4	LED 2	LED; amber, indicates +12 Vdc is present.
5	LED 1	LED; amber, indicates +24 Vdc is present.

● END

3.4 CONTROLS AND INDICATORS

3.4.1 Service Indicators

3.4.3 Motherboard Test Point Indicators

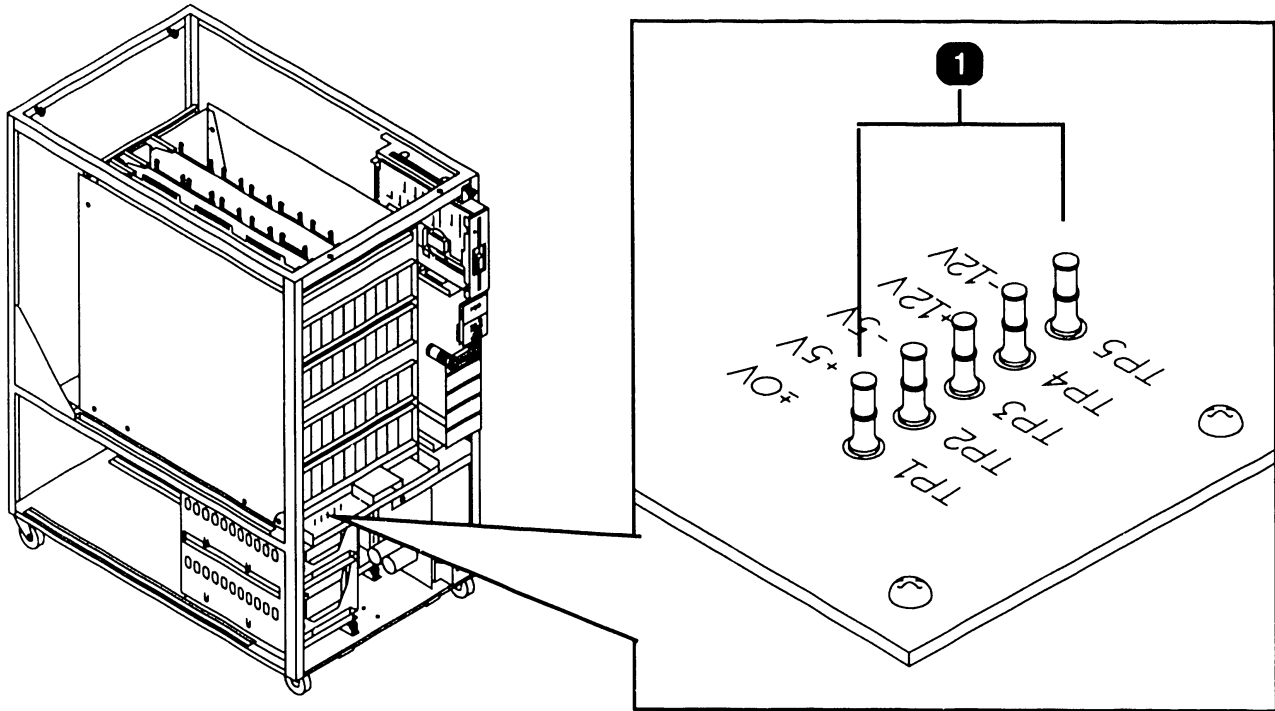

Item	Name	Type and Function
1	Voltage Test Points TP1-TP5	Terminals; voltage test points for checking mainframe dc voltages. (►8.2.1)

● END

SECTION

4

OPERATION

SECTION 4 CONTENTS

SECTION 4 OPERATION

	<u>Page</u>
4.1 POWER-UP AND B.I.T. DIAGNOSTIC PROCEDURE	4-1
4.2 POWER-DOWN PROCEDURE	4-13

4.1 Power-Up and B.I.T. Diagnostic Procedure (sheet 1 of 12)

CAUTION

Never switch mainframe power ON or OFF when a floppy diskette is mounted in the drive.

Perform power-on procedures as follows. Improper power-on procedure may damage disk drive VTOC.

- 1 Power-on external disk drives.
- 2 Power-on workstation 0.

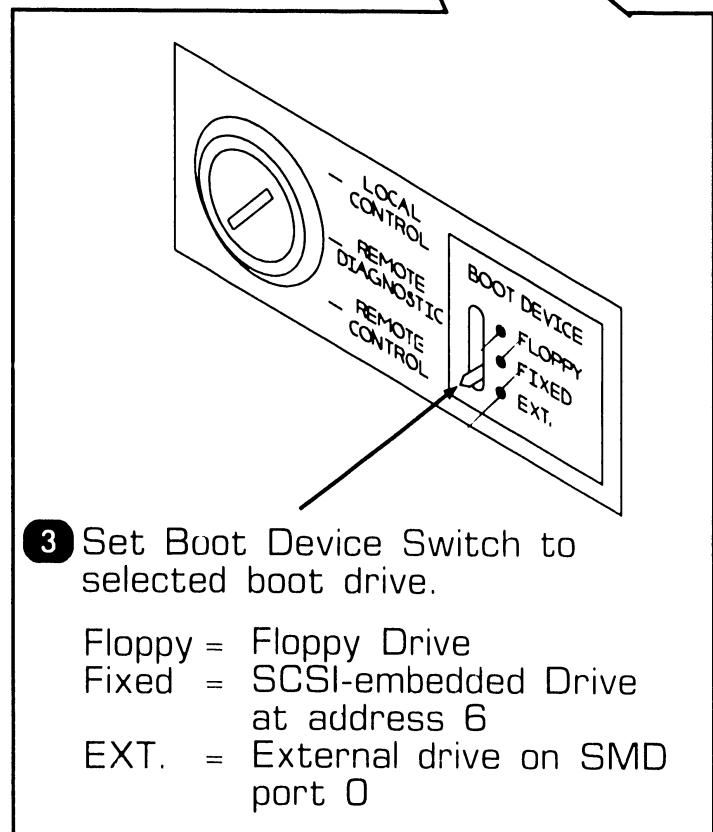
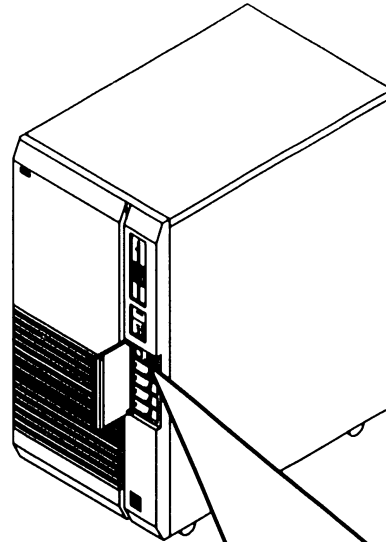

➡NEXT

4.1 Power-Up and B.I.T. Diagnostic Procedure (sheet 2 of 12)

- 4** Set Local/Remote Diagnostic/Remote Control keyswitch to Local position.

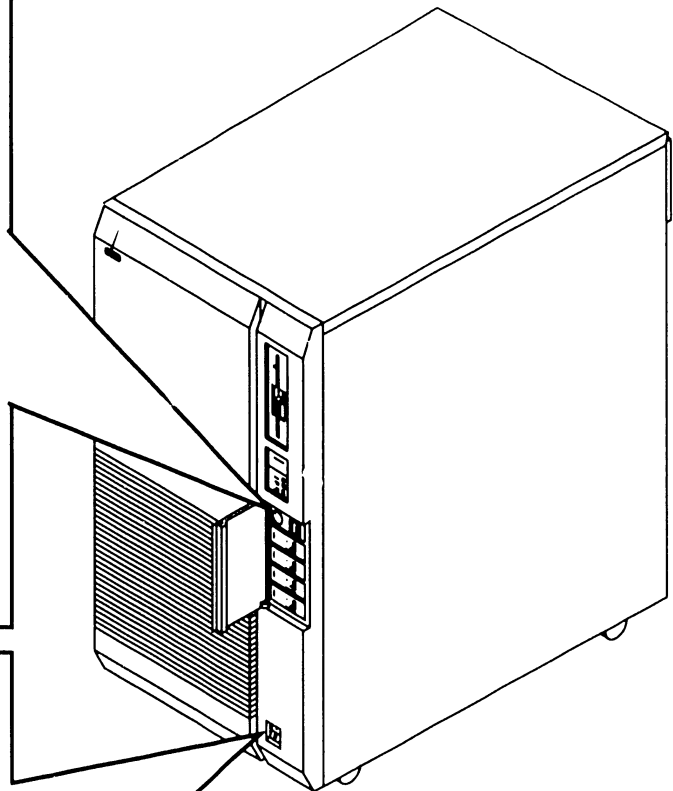
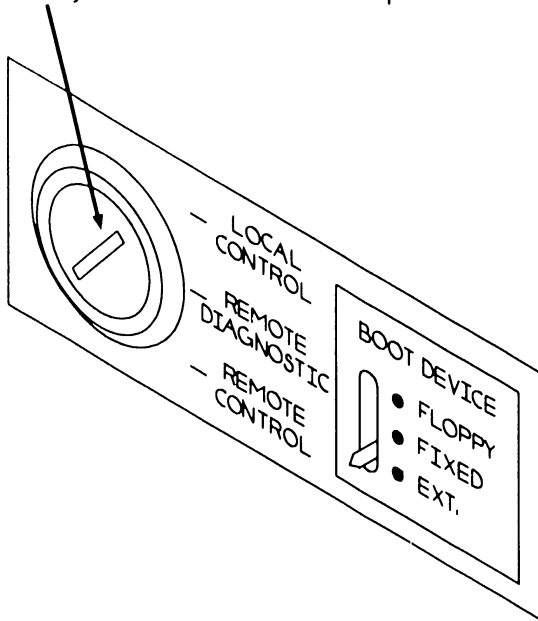

- 5** Press '1' on VS-75E cabinet AC power switch.

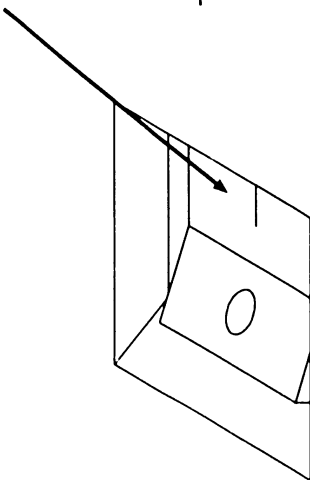

➡ NEXT

4.1 Power-Up and B.I.T. Diagnostic Procedure (sheet 3 of 12)

- 6 Make 'ready' external drives.
- 7 Diagnostic LEDs cycle through Bus Processor BIT tests error codes for 45 seconds or display error code (▶6.2.3).
The following message is displayed on WSO.

IPL MONITOR
Initialization in Progress

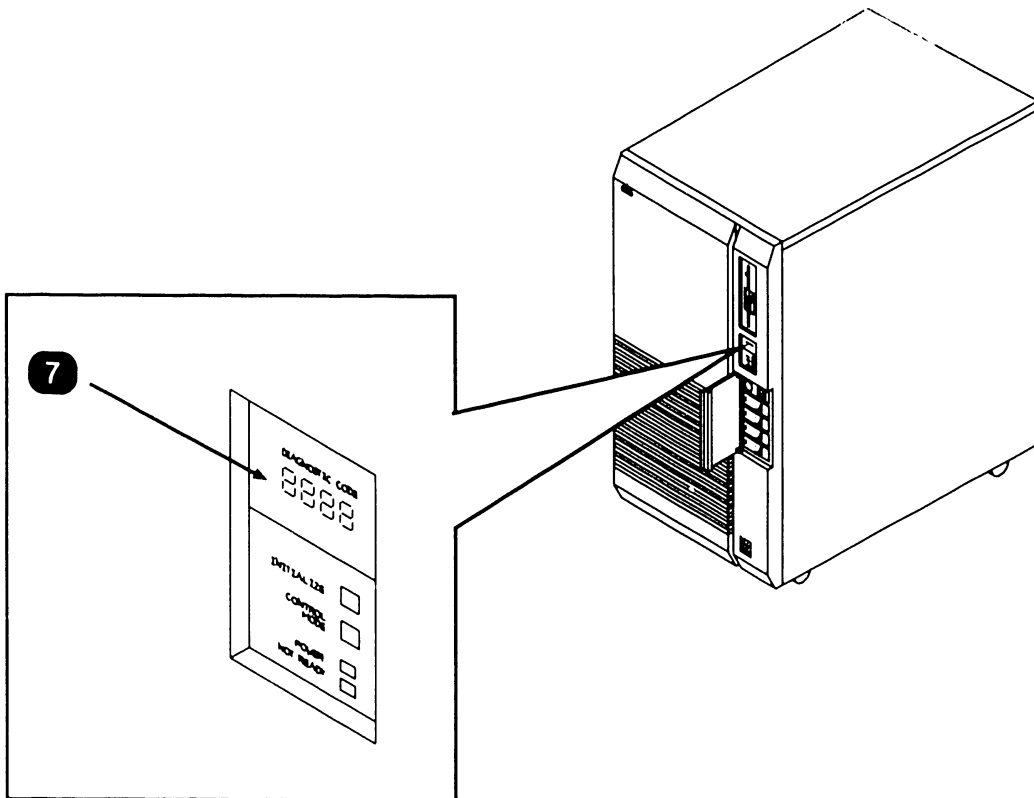

▶NEXT

4.1 Power-Up and B.I.T. Diagnostic Procedure (sheet 4 of 12)

8 Small VS BP2 Class Self Test Package IPL Drive Selection screen is displayed on WSO at end of successful completion of BIT power-up test.

9 Position cursor next to drive the operating system is to be loaded from. Press ENTER. Small VS BP2 Class Self-Test Monitor Screen is displayed and Self-Test begins to run.

NOTE

When screen prompt "Default Test and IPL in Several Seconds" is displayed, pressing any key except Space Bar, Up Arrow, Down Arrow, PF1, PF8, or RETURN will halt the automatic IPL sequence allowing additional time for drive selection.

Small VS BP2 Class Self Test Package Version R2xxx
IPL Drive Selection
Bootstrap Volume = SYSTEM

Device	Capacity	Type	Volume	Status
2270V4	1.2 MB	Dsket		
■2269V4	145 MB	Fixed	SYSTEM	
2269V4	145 MB	Fixed	DATA	

Default Test and IPL in Several Seconds, System Hardware Status

Position Cursor to Indicated Device and Select:

(ENTER)Test & IPL (PF1)IPL Only (PF8)Stand Alone Diagnostc Monitor

➡NEXT

4.1 Power-Up and B.I.T. Diagnostic Procedure (sheet 5 of 12)

Small VS BP2 Class Self Test Monitor Package Version Rxxxx
System hardware Status
System Volume = SYSTEM

Status	Diagnostic
Passed	(SIO) Serial Data Link test
Passed	(BP) USART Loopback Verification Test
Running	(CP7) CM/Communications Test
	(CP7) Operational Test
	(CP7) Integrity Test
	(MM) CPU/Cache/Main Memory Test
	(BP) BP/Main Memory DMA Test
	(MM) Dual Processor M/M Test

10 Self-Test monitor screen indicates the VS-75E is testing system components. Status of each test is displayed with the message sequence: 'Loading', 'Running', 'Passed' or 'Non-Fatal Error'. If the status is 'Passed' the system is ready to begin initialization.

11 When Self-Test Monitor completes, all intelligent PCAs in the system report their Self-Test status (pass or fail) via the Small VS BP2 Class Self Test Package Option Board Status screen. The message 'Loading Operating System in 10 seconds' will then be displayed.

NOTE

Non-Fatal Error messages and Fatal Error messages will display the error code (▶6.4.4).

▶NEXT

4.1 Power-Up and B.I.T. Diagnostic Procedure (sheet 6 of 12)

Small VS BP2 Class Self Test Package Version Rxxxx
System hardware Status
System Volume = SYSTEM

Status	Option Board
--------	--------------

Passed	25V76-1
--------	---------

Loading Operating System in 10 seconds

- 12** Press 'ENTER' to bypass the 10 second delay and load operating system immediately or wait the 10 seconds. The following message is displayed.

Loading System Microcode

- 13** In about 60 seconds, the following message appears on WSO and the Not Read LED turns off.

Loading Complete, Beginning System Initialization

➡NEXT

4.1 Power-Up and B.I.T. Diagnostic Procedure (sheet 7 of 12)

14 The SYSGEN screen is displayed on WSO.

15 The SYSGEN screen displays the name of the configuration file last used (SYSFILE Field). Enter a valid configuration file name in the field 'SYSFILE'. If the system is using communications, specify the communications configuration file name and library.

NOTE

If a configuration file has not been created, the system should be IPL'ed as one workstation and one disk (PF1 key) to allow system configuration file creation using GENEDIT (▶9.8.2).

* * * MESSAGE M001 BY SYSGEN

INFORMATION REQUIRED BY PROGRAM @SYSGEN@

Active Subprogram is @SYSGEN@

Copyright, Wang Laboratories, INC. 1985

Specify the name of the system configuration file and press (ENTER)

-or-

Press (1) to use one workstation and one disk.

SYSFILE= @CONFIG@
SYSLIB = @SYSTEM@

Specify the communications configuration file to be used, if any

COMMFILE= ██████████
COMMLIB = @SYSTEM@

Inhibit logons at all workstations?
Load Microcode to all Devices?
Inhibit Dumping Continuable Halts?

LOGONS = NO
LMCODE = NO
CNDUMP = NO

▶NEXT

4.1 Power-Up and B.I.T. Diagnostic Procedure (sheet 8 of 12)

16 Respond to prompts as follows:

'Inhibit Logons at all workstations? Logons = NO□'

This prompt offers the options to inhibit logon operations for all workstations. If YES is answered, all workstations except WSO will be inhibited from logon operations. Default value is NO.

'Load Microcode to all Devices? LMCODE = NO□'

This prompt allows optional loading of microcode to all devices on the system with loadable microcode, including remote workstations. (Note that most devices load microcode when the device is first powered-on). If YES is selected, the system loads microcode to all microcode loadable devices, thus slowing down the IPL process significantly. Default value is NO.

'Inhibit Dumping Continuable Halts? CNDUMP = NO□'

This prompt enables or disables continuable dumps. If YES is selected, the system does not run continuable dumps, the error remains and system operation may be affected. Default value is NO.

17 Press 'ENTER'. The Initial Program Load (IPL) screen will be displayed.

➡NEXT

OPERATION

4.1 Power-Up and B.I.T. Diagnostic Procedure (sheet 9 of 12)

```
* * * * *
*
* WWWW      WWWW      A      NNN      NNN      GGGGGG
* WW        WW        AAAA   NNN      NN      GG      GG
* WW        WW        AA  AA  NN  N  NN      GG      GG
* WW        WW        AA  AA  NN  N  NN      GG      GG
* WW        WW        AA  AA  NN  N  NN      GG      GG
* WW WWWWW WW  AAAAA AAAA  NN  N  NN      GG      GG
* WWWWW WWWWW  AA  AA  NN  NNN      GG      GG
* WW        WW  AAA  AAA  NNN      NNN      GGGGGG
*
* * * * *

```

(c) Copyright Wang Laboratories, Inc. 1985

O.S. xx.xx.xx **System Generation In Progress** CP: xx.xx.xx

```
VVV      VVV      SSSSSS
VV       VV       SSS  SSS
VV       VV       SSS
VV       VV       SSSSS
VV       VV       SSSSS
VV       VV       SSS
VVVV     SSS  SSS
VV       SSSSSS

```

- 18** The message 'System Generation In Progress' will be displayed in the center of the screen. In about one minute, the Time and Date screen will be displayed.

➡ NEXT

4.1 Power-Up and B.I.T. Diagnostic Procedure (sheet 10 of 12)

* * * MESSAGE WN3 BY IPL

INFORMATION REQUIRED BY PROGRAM @SYSGEN@

SET DATE AND TIME

YEAR = YY

MONTH = MM

DAY = DD

HOUR = HH

MINUTE = MM

SECOND = SS

Memory Size = 02048 K

- 19** Enter the date in the YY/MM/DD format.
Enter the current time using the 24-hour clock format. Press ENTER.

- 20** System initialization will begin. The screen will display the message:

System Initialization In Progress

- 21** When system initialization is completed successfully (about one minute), the Operator's console screen will be displayed.

➡ NEXT

4.1 Power-Up and B.I.T. Diagnostic Procedure (sheet 11 of 12)

* * * Wang VS Operator's Console * * *

10:12 AM Monday August 03, 1987

Position to (*) and Press (ENTER) to Provide Immediate Operator Service:

*MSG from WVR: Queue Verification Routine Complete 10:12

Press (1) to Return to User Mode

-or-

Use the Function Keys to Manage:

- | | |
|--------------------------|------------------------|
| 2) PRINT Queue | 9) PRINTERS |
| 3) PROCEDURE Queue | 10) DISKS |
| 4) TRANSMIT Queue | 11) TAPES |
| 5) RETRIEVE Queue | 12) TELECOMMUNICATIONS |
| | 13) WORKSTATIONS |
| 6) INTERACTIVE Tasks | |
| 7) NON-INTERACTIVE Tasks | 14) SYSTEM Options |

Press (HELP) at Any Time to Return to the Operator Console Menu

22 When message 'Queue Verification Routine Complete' appears (about 20 to 30 seconds) acknowledge message by positioning the cursor next to the message and press RETURN.

23 Press PF1 to enter user mode. The VS Logon Screen will be displayed.

►NEXT

4.1 Power-Up and B.I.T. Diagnostic Procedure (sheet 12 of 12)

```
      * * * Wang VS Logon * * *  
Workstation 0          10:13 AM          Monday August 03, 1987  
      Hello new user  
      Welcome to Wang VS  
  
Please identify yourself by supplying the following information  
  
      Your userid      = ██████████  
      Your password    =  
  
and press (ENTER) to logon  
  
or press (PF11) to enter operator mode immediately
```

- 24** Enter the default three-letter user ID, CSG. No password is required. Press ENTER. The command processor screen will be displayed.

```
      * * * WANG VS COMMAND PROCESSOR * * *  
Workstation 0 Ready   10:15 AM          Monday August 03, 1987  
      Hello  
      Welcome to Wang VS  
  
Press (HELP) at any time to interrupt your program or to stop  
processing of current command.  
  
Use function keys to select a command:  
  
(1) RUN Program or Procedure          (11) Enter OPERATOR Mode  
(2) Set USAGE Constraints              (12) Submit PROCEDURE  
(3) Show PROGRAM Completion Report  
  
(4) Manage QUEUES                     (13) Send MESSAGE to Operator  
(5) Manage FILES/Libraries            (15) PRINT Command Screen  
(6) Manage DEVICES                    (16) LOGOFF
```

- 25** When this screen is displayed, the system has powered-up successfully.

● END

4.2 Power-Down Procedure (sheet 1 of 2)

CAUTION

Powering down of system and/or any external disk drive improperly may result in damage to Volume Table Of Contents (VTOC).

- 1 From Operator's console, press PF13 to verify all users have logged off system.
- 2 From Operator's console, press PF7 (Non-interactive Tasks) to check background tasks on system. Identify any user running a background task, and advise user to suspend or terminate.

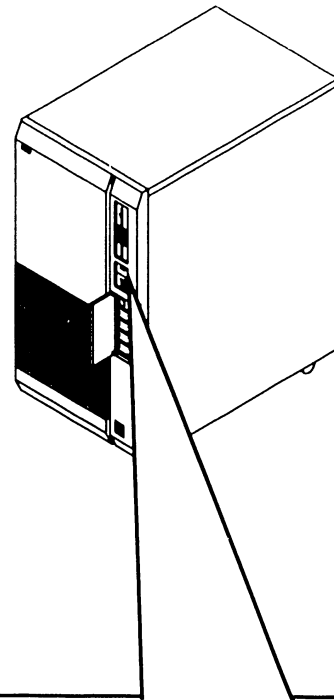

- 3 Press Control Mode (Green) pushbutton. This prevents any disk I/O command in process from being halted before completion.

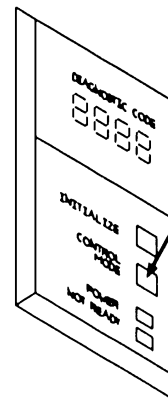

➡ NEXT

4.2 Power-Down Procedure (sheet 2 of 2)

- 4 'Unready' external drives.
Allow drive heads to return to home position.
- 5 Power down all peripheral devices according to procedures in applicable maintenance manual.

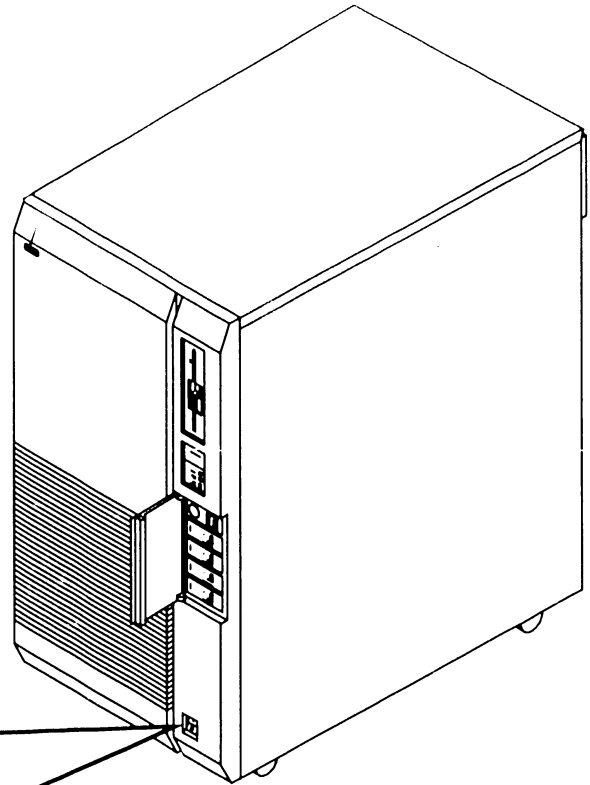

- 6 Press '0' on mainframe AC Power switch.

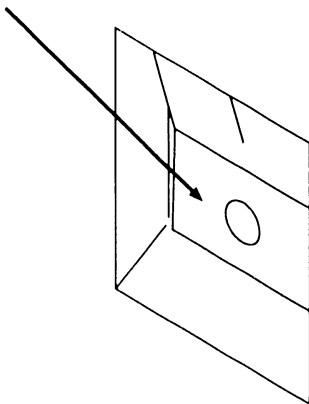

● END

SECTION

5

**PREVENTIVE
MAINTENANCE**

SECTION 5 CONTENTS

SECTION 5 PREVENTIVE MAINTENANCE

	<u>Page</u>
5.1 MATERIALS REQUIRED	5-1
5.2 PM SCHEDULES	5-2
5.3 OPERATIONAL CHECK	5-3
5.4 CLEANING	5-4
5.5 INSPECTION	5-5
5.6 ADJUSTMENTS	5-6

5.1 PREVENTIVE MAINTENANCE

Materials Required

The CE tool kit is required for preventive maintenance (PM) on the VS-75E Computer System.

● END

5.2 PREVENTIVE MAINTENANCE

PM Schedules

The VS-75E Computer System does not require any preventive maintenance. However, the service technician should perform the following while at the site during service calls.

<u>Action</u>	<u>Section</u>
Operational Check (IPL)	5.3
Clean Exterior	5.4
Clean Interior	5.4
Inspect	5.5
Adjust	5.6
Diagnostic Check	6.2

● END

5.3 PREVENTIVE MAINTENANCE

Operational Check

An equipment operational check is recommended after every service call. This test consists of running power-on diagnostics (BIT) and checking the status diagnostics LEDs for possible error codes. This test takes approximately 45 seconds to complete and is activated when the system is initially powered-on and when the Initialize pushbutton is pressed.

Additional diagnostics tests may be performed; Self-Test (▶6.3.1) and Diagnostic Monitor (▶6.3.2) if required.

● END

5.4 PREVENTIVE MAINTENANCE

Cleaning

Exterior:

- 1 Remove dust from exterior with cloth and vacuum.
- 2 Wipe case clean with soft cloth.

Interior:

- 1 Power-down system (▶4.2) and remove top cover, front panel, and side covers (▶7.2.1, 7.2.2, 7.2.3) and vacuum interior.
- 2 Clean fan blades with cloth.

● END

5 5 PREVENTIVE MAINTENANCE

5 Inspection

- 1** Check for loose or damaged parts.
- 2** Check PCA and cable circuitry.
- 3** Check fan operation.

● END

5.6 PREVENTIVE MAINTENANCE

Adjustments

Mechanical:

- 1 None required.

Electrical:

- 1 Power Supply Adjustment:
(▶8.2)

● END

SECTION

6

TROUBLESHOOTING

SECTION 6 CONTENTS

SECTION 6 TROUBLESHOOTING

	<u>Page</u>
6.1 TOOLS AND EQUIPMENT	6-1
6.2 POWER-UP BIT DIAGNOSTICS	6-2
6.2.1 Bus Processor BIT Diagnostics	6-3
6.2.2 Bus Processor BIT Diagnostic Options Switches	6-4
6.2.3 BP2 Class PROM-Based Power-Up BIT Error Codes	6-6
6.2.4 TC Device Adapters Power-Up BIT Diagnostics	6-23
6.2.5 UISIO Controller Power-Up BIT Diagnostics	6-26
6.3 DISKETTE-BASED DIAGNOSTICS	6-27
6.3.1 Self-Test Diagnostics	6-27
6.3.2 Diagnostic Monitor Diagnostics	6-28
6.3.3 CP7E Diagnostic Monitor Routines	6-29
6.3.4 Loading Diagnostic Monitor and Self-Test Onto IPL Drive ..	6-31
6.3.5 Running Diagnostic Monitor From Bootstrap Volume	6-33
6.3.5.1 Running Selected Monitor Diagnostics	6-38
6.3.5.2 Run-Time Menu Screen Commands and Descriptors	6-39
6.3.5.3 Interpreting the Diagnostic Monitor Error Log	6-42
6.3.6 Running Self-Test Diagnostic	6-44
6.4 ERROR CODES AND DESCRIPTIONS	6-45
6.4.1 BP2 Class Microcode Error/Status Codes and Description ..	6-45
6.4.2 BP2 Class System Error/Status Codes and Description ..	6-51
6.4.3 BP2 Class Diagnostic Monitor Error Codes and Description ..	6-52
6.4.4 Self-Test Diagnostic Execution Error Codes and Description ..	6-69
6.5 TROUBLESHOOTING FLOWCHARTS	6-89
6.5.1 Power-Up Procedure	6-89

6.1 Tools and Equipment

Tools and equipment required to troubleshoot the VS 75E Computer system consists of a standard CE tool kit, a DVM, and three diagnostic test routines, namely Power-Up BIT diagnostic, Self-Test diagnostics, and Diagnostic Monitor.

Self-Test diagnostics and Diagnostic Monitor routines are contained on separate diskettes (or loaded on the System drive) and should be available when troubleshooting at the customer's site to aid in isolating system problems. The diskette-based troubleshooting diagnostics are described in section 6.3.

● END

TROUBLESHOOTING

6.2 Power-Up BIT Diagnostics

Power Up BIT diagnostics are PROM based resident on the BP PCA, and other intelligent controller PCAs. Power Up BIT test run every time the VS-75E computer is powered-on (IPL'ed) or initialized.

Power-up diagnostics do rudimentary testing and verification of the most basic aspects of a given PCA. Currently, four PCAs have PROM-based core diagnostics: the Bus Processor, the Telecommunication Device Adapter (TC DA), the Universal Intelligent Serial Input/Output Device Adapter (UISIO DA), and the SMD Disk Controllers.

All device adapters run power-up diagnostics concurrently with the Bus Processor when the system is IPL'ed. When an error occurs, the DA will report the error to the Front Panel display via the Bus Processor.

● END

6.2 Power-Up BIT Diagnostics

6.2.1 Bus Processor BIT Diagnostics

PROM based core diagnostics allow the Bus Processor to verify its internal operation and its interface to the selected bootstrap device prior to loading the BP Core RAM (CRAM) intelligence. Circuitry which requires signals that are not internal to the BP or used to bootstrap the system are not tested or verified. This includes circuitry such as the Main Memory DMA and the Real Time Clock (RTC).

Beginning with the decrementing of the Front Panel's four-character Hex display, the Bus Processor initiates the loading and/or testing of a number of basic core functions (e.g. verifies its PROM (checksum), loads and verifies the Programmable Interrupt Controllers and Interrupt Timers, etc).

The BP then tests the Code RAM (CRAM) and Data RAM (DRAM) integrity and function, communication with data and addressing lines, and parity error detection. The bootstrap device is tested and its diagnostic space (cylinder) is verified.

After successfully completing its PROM-based diagnostics and loading the VTOC handler (@MCBOOT@), the BP reads its diagnostic switches to determine its next operation. If all switches are in the standard operational position (►7.2.7), the BP will find and load the software. If an error occurs during BP power-up diagnostics an error code will be displayed.

● END

TROUBLESHOOTING

6.2 Power-Up BIT Diagnostics

6.2.2 Bus Processor BIT Diagnostic Options Switches (Sheet 1 of 2)

Switch SW2 on the BP selects certain operating modes for the BIT diagnostics. SW2 switches 1 and 2 (WSO Location) and switch 3 (Clock speed) are not used for diagnostic purposes. When SW2 switch 8 is closed (On), the IPL control switches 7 and 6 are enabled allowing the BIT to be bypassed. It is recommended that SW2-8 remain Open (Off) to allow BIT

Diagnostics to run power up (initialize). If the BIT detects an error, it will stop and display the test number (left, two error codes) and the error number (right, two error codes). The various BIT operating modes as selected by SW2 are:

BP BIT OPTIONS SWITCH SETTINGS

SW2 Switch No.	Status	Function															
8	ON OFF	Enables switch number 5, 6, and 7 for IPL Control. Forces normal IPL, disables switches 5, 6 and 7.															
7 and 6		IPL Control: Selects IPL without running BIT. The selections are as follows: <table border="1"><thead><tr><th>Switch 7</th><th>Switch 6</th><th></th></tr></thead><tbody><tr><td>OFF</td><td>OFF</td><td>Normal System IPL.</td></tr><tr><td>OFF</td><td>ON</td><td>Bypass BIT and Self-Test, IPL system.</td></tr><tr><td>ON</td><td>xxx</td><td>Bypass BIT and load Diagnostic Monitor</td></tr><tr><td>xxx</td><td>don't care</td><td></td></tr></tbody></table>	Switch 7	Switch 6		OFF	OFF	Normal System IPL.	OFF	ON	Bypass BIT and Self-Test, IPL system.	ON	xxx	Bypass BIT and load Diagnostic Monitor	xxx	don't care	
Switch 7	Switch 6																
OFF	OFF	Normal System IPL.															
OFF	ON	Bypass BIT and Self-Test, IPL system.															
ON	xxx	Bypass BIT and load Diagnostic Monitor															
xxx	don't care																
5	ON OFF	LOOP ON BIT: BIT executes repeatedly until switch 5 is set to OFF. Boot on successful BIT completion.															
4	ON OFF	LOOP ON ERROR: An error will cause the BIT to automatically execute a 'retry' each time it encounters the error, until the BIT passes or switch 4 is set to OFF. Halt On Error: BIT test halts on the error and displays the error code.															
3 1		Ignored by BIT.															

➡ NEXT

6.2 TROUBLESHOOTING

6.2 Power-Up BIT Diagnostics

6.2.2 Bus Processor BIT Diagnostic Options Switches (Sheet 2 of 2)

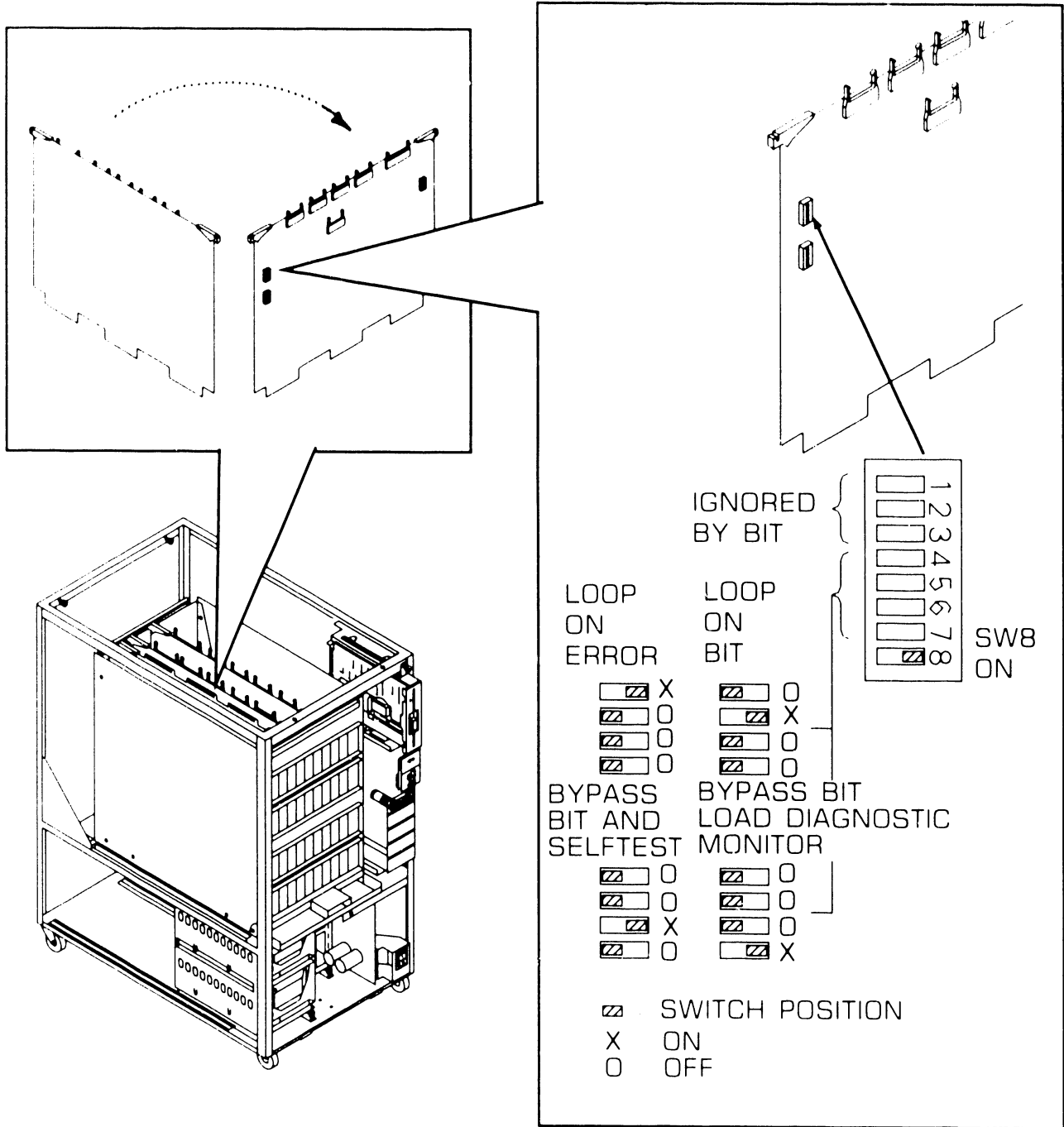

● END

6.2 TROUBLESHOOTING

6.2 Power-Up BIT Diagnostics

6.2.3 BP2 Class PROM-Based Power-Up BIT Error Codes (Sheet 1 of 17)

The following tables presents a list of VS 75E BIT Error Codes, test error descriptions, and the Suspected Failed Assembly for each code. The first table is a general quick check list of the error codes, the second table contains all Bus Processor BIT generated error codes. The error code is read from the front panel leds with the two left most characters being the test number and the two right most characters being the routine number within the test. The abbreviations of the Suspected Failed Assemblies and acronyms outlined in the table are:

List of Suspected Failed Assemblies (SFA)

- “BP” - Bus Processor
- “SCSI” - SCSI Drive
- “FL” - Floppy Drive
- “CBL” - Cables
- “FP” - Front Panel
- “Media” - Floppy Media or Winchester
- “DA” - Device Adapter
- “PS” - Power Supply
- “CP” - Central Processor
- “MM” - Main Memory

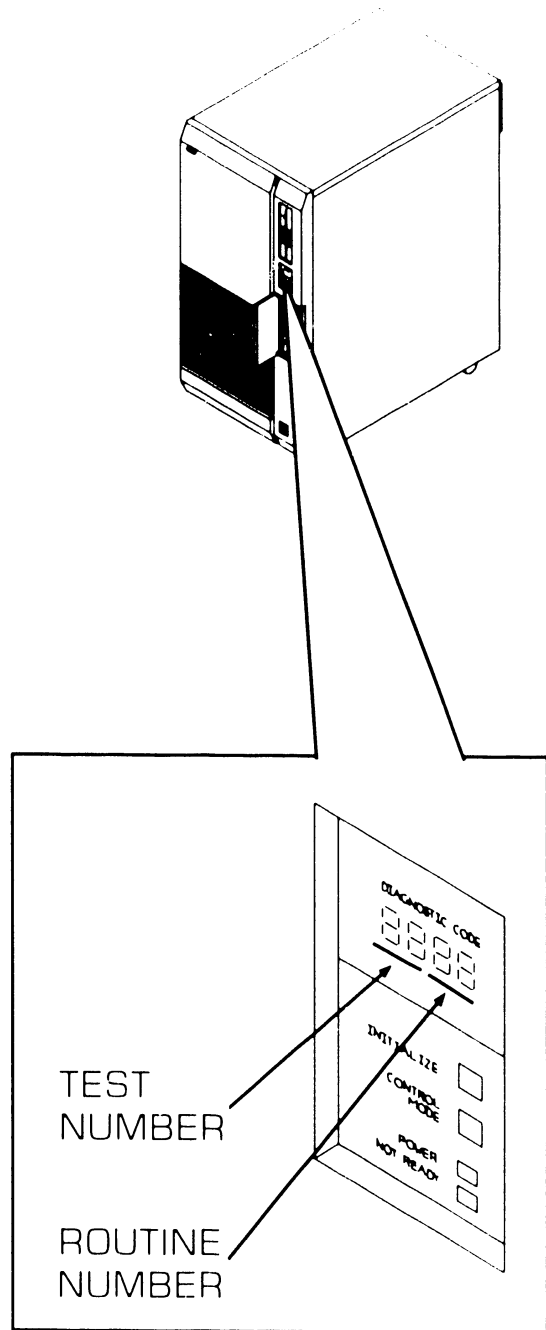

6.2

TROUBLESHOOTING

Power-Up BIT Diagnostics

6.2.3 BP2 Class PROM-Based Power-Up BIT Error Codes (Sheet 2 of 17)

General BP2 Class PROM Power-Up BIT Generated Error Codes

<i>General</i>	<i>Specific</i>	<i>Error Name</i>	<i>S.F.A.</i>
00xx	00 - 09	Bus Processor and BP Operational Code	BP, FP, PS
02xx	00	PROM Power-On & Initialize	BP
04xx	02	PROM Checksum	BP
06xx	00	DUART Check	BP
08xx	02	I/O Comm. Check	BP
0Axx	00 - 14	Programmable Interrupt Test	BP
0Cxx	00 - 44	80186 Internal Timer Test	BP, CP, MM
0Dxx	02 - 06	Wait State Generator	BP
0Exx	xx	Front Panel Interface Check	BP, FP, No explicit codes
10xx	00 - 04	Code RAM Data Line Test	BP
12xx	01 - 04	Data RAM Data Line Test	BP, DA

➡ NEXT

6.2

Power-Up BIT Diagnostics

TROUBLESHOOTING

6.2.3 BP2 Class PROM-Based Power-Up BIT Error Codes (Sheet 3 of 17)

General BP2 Class PROM Power-Up BIT Generated Error Codes

<i>General</i>	<i>Specific</i>	<i>Error Name</i>	<i>S.F.A.</i>
14xx	00 - 18	Code RAM Parity Test	BP
16xx	00 - 08	Code RAM Byte Bank Decode	BP
18xx	00 - 08	Data RAM Byte Decode	BP
1Axx	00 - 18	Code RAM Address Line Test	BP
1Cxx	00 - 08	Data RAM Address Line	BP
1Exx	00 - 0A	Code RAM Data Integrity	BP
20xx	00 - 04	Data RAM Data Integrity	BP
22xx	00 - 04	Code RAM Refresh	BP
24xx	00 - 0C	Code RAM Odd Word Byte Move	BP
26xx	00 - 0C	Data RAM Odd Word Byte Move	BP
28xx	00 - 04	Code RAM Parity Error Int.	BP

▶ NEXT

6.2 Power-Up BIT Diagnostics

TROUBLESHOOTING

6.2.3 BP2 Class PROM-Based Power-Up BIT Error Codes (Sheet 4 of 17)

General BP2 Class PROM Power-Up BIT Generated Error Codes

<i>General Specific Error Name</i>			<i>S.F.A.</i>
2Axx	00 - 24	Memory To Memory DMA Test	BP
38xx	00	Floppy Device Interface	BP
39xx	xx	Device Reset Function error	BP, xx=Specific Oper.
3Axx	xx	Device Identify Error	BP, FL, Media, CBL xx=Specific Operation
3Bxx	xx	Multi-Block Read Error	BP, FL, Media, CBL xx=Specific Operation
3Exx	xx - FF	Unexpected Interrupt	BP, DA, xx=Interrupt
40xx	00 - xE	Bootstrap File Loader	BP, Media, FL, SCSI x=Device/Operation
50xx	00	SCSI Device Interface Test	BP
51xx	xx	Device Reset Error	BP, SCSI xx=Specific Operation
52xx	xx	Device Identify Error	BP, SCSI, Media xx=Specific Operation
53xx	xx	Multi-Block Read Error	BP, SCSI, Media xx=Specific Operation
B0xx	00 - 94	SMD Device Interface Test	BP, SMD DA, Media, CBL

►NEXT

6.2 Power-Up BIT Diagnostics

TROUBLESHOOTING

6.2.3 BP2 Class PROM-Based Power-Up BIT Error Codes (Sheet 5 of 17)

BP2 Class BIT Error Code Analysis

<i>Error Code</i>	<i>Test/Error Description</i>	<i>S.F.A.</i>
00	I-ROM Power On And Initialization	
0000	80186 hung on jump to diagnostic start or during	BP, PS,
0001	chip select programming	FP
	80186 hung during processor register initialization	BP
02	PROM Power On And Initialization	
0200	80186 hung during processor register initialization	BP
04	PROM Checksum Verification	
0402	Checksum error	BP
06	2861 DUART Communications Check & Remote Channel Initialization	
0600	80186 hung	BP
08	I/O Communication Check	
0802	Data write/verify failure on Data RAM DMA MAR	BP
0A	Programmable Interrupt Controller Initialization & Test	
0A00	80186 hung	BP
0A10	Mask register write/verify failure on master 8259A	BP
0A11	Mask register write/verify failure on slave 8259A #1	BP
0A12	Mask register write/verify failure on slave 8259A #2	BP
0A13	Mask register write/verify failure on slave 8259A #3	BP
0A14	Mask register write/verify failure on slave 8259A #4	BP

►NEXT

TROUBLESHOOTING

6.2 Power-Up BIT Diagnostics

6.2.3 BP2 Class PROM-Based Power-Up BIT Error Codes (Sheet 6 of 17)

BP2 Class BIT Error Code Analysis

<i>Error Code</i>	<i>Test/Error Description</i>	<i>S.F.A.</i>
OC	30186 Programmable Internal Timer Test	
OC00	80186 hung	BP
OC10	Timer Channel 0 count incorrect	BP
OC12	Timer Channel 1 count incorrect	BP
OC14	Timer Channel 2 count incorrect	BP
OC20	No interrupt from Channel 0	BP, CP, MM
OC22	Interrupt received not channel 0	BP
OC24	No max count status from channel 0	BP, CP, MM
OC30	No interrupt from channel 1	BP
OC32	Interrupt received not channel 1	BP
OC34	No max count status from channel 1	BP
OC40	No interrupt from channel 2	BP
OC42	Interrupt received not channel 2	BP
OC44	No max count status from channel 2	BP
OD	Wait State Generator	
OD02	Wait State Generator Failed Enable/Disable Switch	BP
OD04	Wait State Generator Failed Max/Min Test	BP
OD06	Wait State Generator Failed Timing Test	BP
OE	Front Panel Interface Check	
	No explicit codes reported during this test. See program documentation for test details.	BP, FP, CBL

▶ NEXT

6.2 TROUBLESHOOTING

6.2 Power-Up BIT Diagnostics

6.2.3 BP2 Class PROM-Based Power-Up BIT Error Codes (Sheet 7 of 17)

BP2 Class BIT Error Code Analysis

<i>Error Code</i>	<i>Test/Error Description</i>	<i>S.F.A.</i>
10	Code RAM Data Line Test	
1000	80186 hung, see program documentation	BP
1002	Data write/verify miscompare	BP
1004	Unexpected parity error	BP
12	Data RAM Data Line Test	
1200	80186 hung, see program documentation	BP, DA
1202	Data write/verify miscompare	BP
1204	Unexpected Code RAM parity error	BP
14	Code RAM Parity Generator/Checker Test	
1400	80186 hung, see program documentation	BP
1402	Low byte data write/verify miscompare (normal parity)	BP
1404	Low byte unexpected parity error	BP
1406	Low byte data write/verify miscompare (forced parity)	BP
1408	Low byte forced parity error not detected	BP
1412	High byte data write/verify miscompare (normal parity)	BP
1414	High byte unexpected parity error	BP
1416	High byte data write/verify miscompare (forced parity)	BP
1418	High byte forced parity error not detected	BP
16	Code RAM Byte Bank Decode Address Line Test	
1600	80186 hung, see program documentation	BP
1602	Data write/verify miscompare current bank address	BP
1604	Unexpected parity error current bank address	BP
1606	Data write/verify miscompare test bank address	BP
1608	Unexpected parity error test bank address	BP

►NEXT

6.2 Power-Up BIT Diagnostics

TROUBLESHOOTING

6.2.3 BP2 Class PROM-Based Power-Up BIT Error Codes (Sheet 8 of 17)

BP2 Class BIT Error Code Analysis

<i>Error Code</i>	<i>Test/Error Description</i>	<i>S.F.A.</i>
18	Data RAM Byte Decode Test	
1800	80186 hung, see program documentation	BP
1802	Data write/verify miscompare current bank address	BP
1804	Unexpected Code RAM parity error current bank address	BP
1806	Data write/verify miscompare test bank address	BP
1808	Unexpected Code RAM parity error test bank address	BP
1A	Code RAM Address Line Test	
1A00	80186 hung, see program documentation	BP
1A02	Data write/verify miscompare current offset address	BP
1A04	Unexpected parity error	BP
1A06	Data write/verify miscompare test offset address	BP
1A08	Unexpected parity error	BP
1A12	Data write/verify miscompare current segment address	BP
1A14	Unexpected parity error	BP
1A16	Data write/verify miscompare test segment address	BP
1A18	Unexpected parity error	BP
1C	Data RAM Address Line Test	
1C00	80186 hung, see program documentation	BP
1C02	Data write/verify miscompare current address	BP
1C04	Unexpected parity error	BP
1C06	Data write/verify miscompare test address	BP
1C08	Unexpected parity error	BP

►NEXT

6.2

TROUBLESHOOTING

Power-Up BIT Diagnostics

6.2.3 BP2 Class PROM-Based Power-Up BIT Error Codes (Sheet 9 of 17)

BP2 Class BIT Error Code Analysis

<i>Error Code</i>	<i>Test/Error Description</i>	<i>S.F.A.</i>
1E	Code RAM Data Integrity Test	
1E00	80186 hung, see program documentation	BP
1E02	Data exchange miscompare pattern #1	BP
1E04	Unexpected parity error pattern #1	BP
1E06	Data exchange miscompare pattern #2	BP
1E08	Data verify miscompare pattern #3	BP
1E0A	Unexpected parity error pattern #3	BP
	Data patterns used: #1 AA55H (even parity) #2 55AAH (even parity) #3 2A54H (odd parity)	
20	Data RAM Data Integrity Test	
2000	80186 hung, see program documentation	BP
2002	Data exchange miscompare patterns #1-5	BP
2004	Data verify miscompare pattern #6	BP
	Data patterns used: #1 OFF0H #4 CC33H #2 F00FH #5 55AAH #3 33CCH #6 AA55H	
22	Code RAM Refresh Test	
2200	80186 hung, see program documentation	BP
2202	Data verify miscompare	BP
2204	Unexpected parity error	BP

►NEXT

6

.2 Power-Up BIT Diagnostics

TROUBLESHOOTING

6.2.3 BP2 Class PROM-Based Power-Up BIT Error Codes (Sheet 10 of 17)

BP2 Class BIT Error Code Analysis

<i>Error Code</i>	<i>Test/Error Description</i>	<i>S.F.A.</i>
24	Code RAM Odd Word/Byte Move Test	
2400	80186 hung, see program documentation	BP
2402	Odd address word data write/verify miscompare pattern #1	BP
2404	Odd address word string move/verify miscompare pattern #1	BP
2406	Odd address byte data write/verify miscompare pattern #2	BP
2408	Odd address byte string move/verify miscompare pattern #2	BP
240A	Even address byte data write/verify miscompare pattern #3	BP
240C	Even address byte string move/verify miscompare pattern #3	BP
	Data patterns used: #1 AA55H (Word) #2 AAH (Byte) #3 55H (Byte)	

►NEXT

6.2 Power-Up BIT Diagnostics

6.2.3 BP2 Class PROM-Based Power-Up BIT Error Codes (Sheet 11 of 17)

BP2 Class BIT Error Code Analysis

<i>Error Code</i>	<i>Test/Error Description</i>	<i>S.F.A.</i>
26	Data RAM Odd Word/Byte Move Test	
2600	80186 hung, see program documentation	BP
2602	Odd address word data write/verify miscompare pattern #1	BP
2604	Odd address word string move/verify miscompare pattern #1	BP
2606	Odd address byte data write/verify miscompare pattern #2	BP
2608	Odd address byte string move/verify miscompare pattern #2	BP
260A	Even address byte data write/verify miscompare pattern #3	BP
260C	Even address byte string move/verify miscompare pattern #3	BP
	Data patterns used: #1 AA55H (Word) #2 AAH (Byte) #3 55H (Byte)	

▶NEXT

6.2 Power-Up BIT Diagnostics

TROUBLESHOOTING

6.2.3 BP2 Class PROM-Based Power-Up BIT Error Codes (Sheet 12 of 17)

BP2 Class BIT Error Code Analysis

<i>Error Code</i>	<i>Test/Error Description</i>	<i>S.F.A.</i>
28	Code RAM Parity Error Interrupt Test	
2800	80186 hung, see program documentation	BP
2802	No forced parity error status detected by polling interrupt controller	BP
2804	No forced parity error interrupt detected	BP
2A	Memory To Memory 80186 DMA Test	
2A00	80186 hung, see program documentation	BP
2A10	No channel 0 terminal count status detected	BP
2A12	No channel 0 interrupt status detected	BP
2A14	Data verify miscompare after DRAM to CRAM transfer	BP
2A20	No channel 1 terminal count status detected	BP
2A22	No channel 1 interrupt status detected	BP
2A24	Data verify miscompare after DRAM to CRAM transfer	BP
38	Floppy Device Interface Test	
NOTE		
This routine is invoked by the bootstrap loader only if the floppy is selected as the bootstrap device.		
3800	80186 hung, see program documentation	BP
39xx	Device reset function error	BP
3Axx	Device identify function error	BP, CBL, FI, Media

►NEXT

6.2 Power-Up BIT Diagnostics

6.2.3 BP2 Class PROM-Based Power-Up BIT Error Codes (Sheet 13 of 17)

BP2 Class BIT Error Code Analysis

<i>Error Code</i>	<i>Test/Error Description</i>	<i>S.F.A.</i>
38	Floppy Device Interface Test (Cont.)	
3Bxx	Multi-Block read function error Where xx = Specific Operation Status: 02 Floppy Disk Controller (FDC) status error after drive select 04 Device not ready 06 FDC Command phase sequence error 08 No completion interrupt detected 0A No result phase 0C FDC result phase sequence error 0E Error in operation status 82 No device present 84 FDC chip operational failure after reset 86 Invalid unit number requested 88 Device/parameter calculations error	BP, CBL, FI, Media
3E	Expected Interrupt Handler	
3Eyy	Unexpected interrupt, yy = Intel interrupt type service	BP
3EFF	Unexpected interrupt, type unknown	BP, DA

►NEXT

6.2 Power-Up BIT Diagnostics

6.2.3 BP2 Class PROM-Based Power-Up BIT Error Codes (Sheet 14 of 17)

BP2 Class BIT Error Code Analysis

<i>Error Code</i>	<i>Test/Error Description</i>	<i>S.F.A.</i>
40	Bootstrap File Loader	
4000	80186 hung, see program documentation	BP
40x0	Non-VS labeled volume	Media
40x1	Bootstrap device media error (ID, CRC, ECC)	BP, SCSI, Media, DA
40x2	Bootstrap device hardware error (controller or drive)	BP, SCSI, FI, CBL, Media, DA
40x4	Bootstrap device not ready	SCSI, FL, CBL
40x8	Parameter error/BP failure	BP
40xA	Invalid pointer in volume label (non-bootstrap volume)	Media
40xC	Bootstrap file checksum error	Media
40xE	Bootstrap device address computation error	Media

Where x = device/operation:

- 1 Volume label read from external SMD
- 2 Volume label read from floppy
- 3 Volume label read from SCSI
- 9 Bootstrap file read from external SMD
- A Bootstrap file read from floppy
- B Bootstrap file read from SCSI

►NEXT

6.2

TROUBLESHOOTING

Power-Up BIT Diagnostics

6.2.3 BP2 Class PROM-Based Power-Up BIT Error Codes (Sheet 15 of 17)

BP2 Class BIT Error Code Analysis

<i>Error Code</i>	<i>Test/Error Description</i>	<i>S.F.A.</i>
50	SCSI Device Interface Test	
NOTE		
This routine is invoked by the bootstrap loader only if the fixed device (SCSI) is selected as the bootstrap device. SCSI bootstrap currently supports the SCSI device at address 6 only.		
5000	80186 hung, see program documentation	BP
51xx	Device reset function error	BP, SCSI, CBL
52xx	Device identify function error	BP, SCSI, CBL
53xx	Multi-Block read function error	BP, SCSI, CBL
Where xx = Specific Operation Status:		
1x Command completed successfully (See Note 1)		
2x Pause or aborted interrupt (See Note 1)		
4x Terminated interrupt (See Note 1)		
8x Service required interrupt (See Note 1)		
72 Device not ready		
73 Media error (ID, ECC)		
74 Hardware error (controller or drive)		
75 Illegal request or parameter		
76 Unit attention (controller reset or disk changed)		

➡NEXT

6.2 Power-Up BIT Diagnostics

TROUBLESHOOTING

6.2.3 BP2 Class PROM-Based Power-Up BIT Error Codes (Sheet 16 of 17)

BP2 Class BIT Error Code Analysis

<i>Error Code</i>	<i>Test/Error Description</i>	<i>S.F.A.</i>
50	SCSI Device Interface Test (Cont.)	
53xx	Multi-Block read function error (cont.) Where xx = Specific Operation Status: 77 Access to protected block attempt 7B Command aborted by controller 90 Requested device not present 92 Parameter/calculation error 94 Unit busy or reserved C2 Operation completion timeout C4 Device select timeout DC Request sense operation failure (unable to retrieve status) F0 Unknown/undecipherable SCSI error occurred	BP, SCSI, CBL

NOTE 1

Refer to the WD33C93 SCSI Bus Interface Controller Manual for details.

◆NEXT

6.2 Power-Up BIT Diagnostics

6.2.3 BP2 Class PROM-Based Power-Up BIT Error Codes (Sheet 17 of 17)

BP2 Class BIT Error Code Analysis

<i>Error Code</i>	<i>Test/Error Description</i>	<i>S.F.A.</i>
B0	SMD Device Interface Test	
NOTE		
This routine is invoked by the bootstrap loader only if the external device (SMD) is selected as the bootstrap device.		
B000	80186 hung, see program documentation	BP
B1xx	Device reset function error	BP, CBL, SMD DA
B2xx	Device identify function error	BP, CBL, SMD DA
B3xx	Multi-Block read function error Where xx = Specific Operation Status: 04 Drive not ready 12 No DA at specified address 14 Invalid DA port number 22 DA Reset failure 32 Drive select failure 34 Drive fault clear failure 42 No seek complete interrupt on restore 48 No seek complete interrupt on seek 52 Uncorrectable data ECC error 62 No operation complete interrupt on restore 68 No operation complete interrupt on read correction 82 Drive error on restore 84 Drive error on seek 86 Drive error on read 92 Header check error on read 94 General error on read	BP, CBL, SMD DA, Media

● END

6.2 Power-Up BIT Diagnostics

TROUBLESHOOTING

6.2.4 TC Device Adapters Power-Up BIT Diagnostics (Sheet 1 of 3)

TC (Telecommunications) Device Adapters (1-port and 2-port) run PROM-based power-up diagnostics concurrently with the BP power-up diagnostics and completes within ten seconds. The TC Light Panel displays DA status during power-up as follows:

LED 8	LED 7-1	TC DA STATUS
Blinking	All On	Test Running
On	All Off	Test Passed
Blinking	LED 7-1 Some On/ Some Off	Test Failed

Switch SW1 on the 1-Port TC DA and switch SW1 and SW2 on 2-Port TC DA selects various operating modes for BIT diagnostics. SW1/2 switches 7 and 8 are not used for diagnostic purposes. Switch 5 when ON selects Bypass All Power-Up tests. It is recommended that switch 5 remains Open (Off) to allow BIT diagnostics on power-up. If the BIT detects an error, it will stop and display the error number (0060-006F) on the front panel display and TC Light Panel LEDs. The various BIT operating modes as selected by SW1 and SW2 are:

TC DA Bit Options Switch Settings

<i>SW1/SW2 Switch No.</i>	<i>Status</i>	<i>Function</i>
8 and 7		Ignored by BIT.
6	ON OFF	LOOP ON TEST: Repeat current TC DA Test. Normal IPL.
5	ON	BYPASS ALL POWER-UP TESTS:
4	ON	STOP ON ERROR: BIT test halts on error and displays error code on TC LED display and Front Panel display. Requires switch 3 ON.
3	ON	LOOP ON ERROR: Repeat any test in error.
2	ON	EXTERNAL LOOPBACK: Loopback test of RS232 connector. Requires RS232 Loopback Connector.
1	ON	LOOP ON BIT: Repeats TC BIT Diagnostics until switch 1 is set to OFF.

◆NEXT

6.2 Power-Up BIT Diagnostics

TROUBLESHOOTING

6.2.4 TC Device Adapters Power-Up BIT Diagnostics (Sheet 2 of 3)

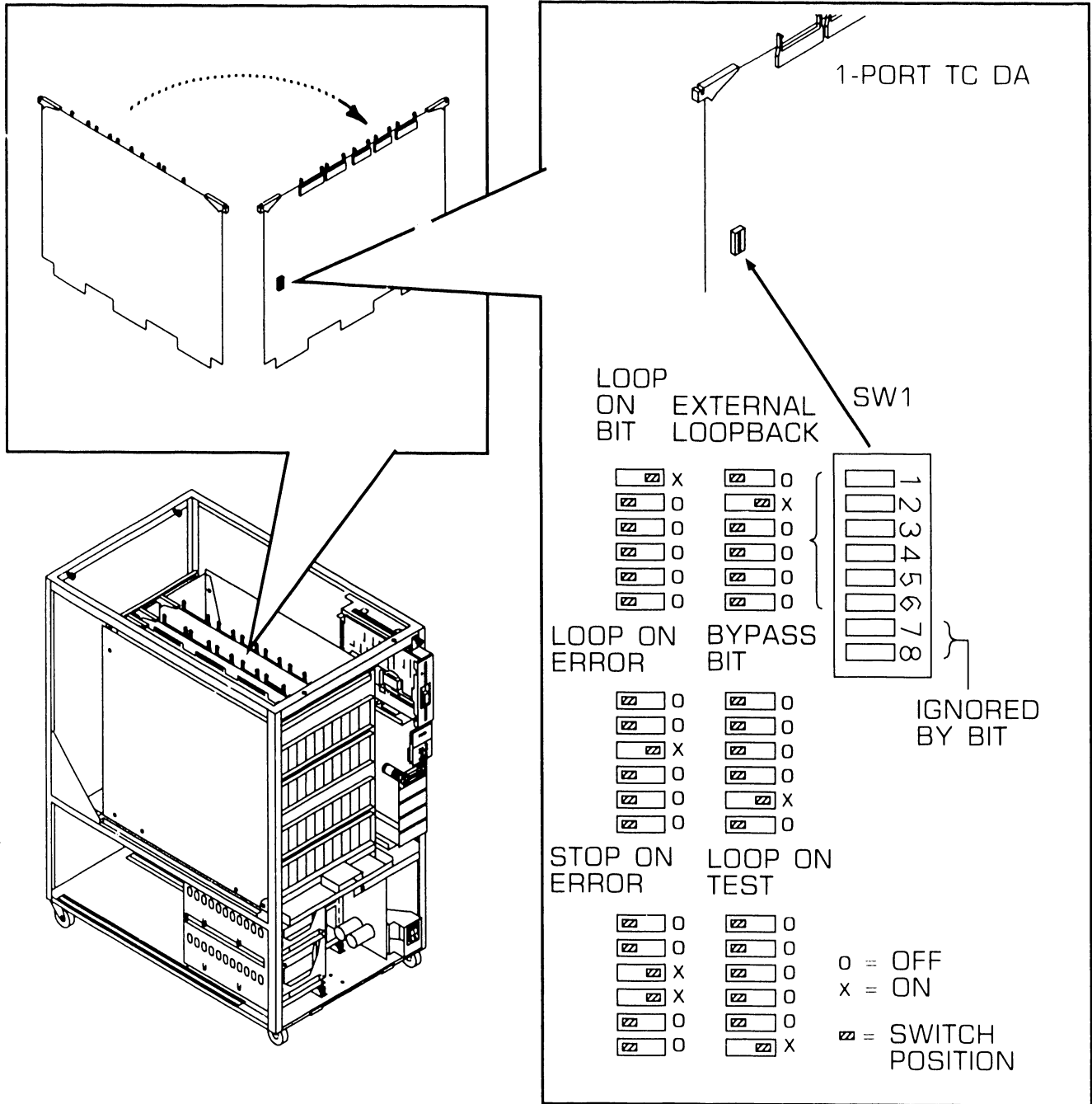

➡ NEXT

6.2 TROUBLESHOOTING

6.2 Power-Up BIT Diagnostics

6.2.4 TC Device Adapters Power-Up BIT Diagnostics (Sheet 3 of 3)

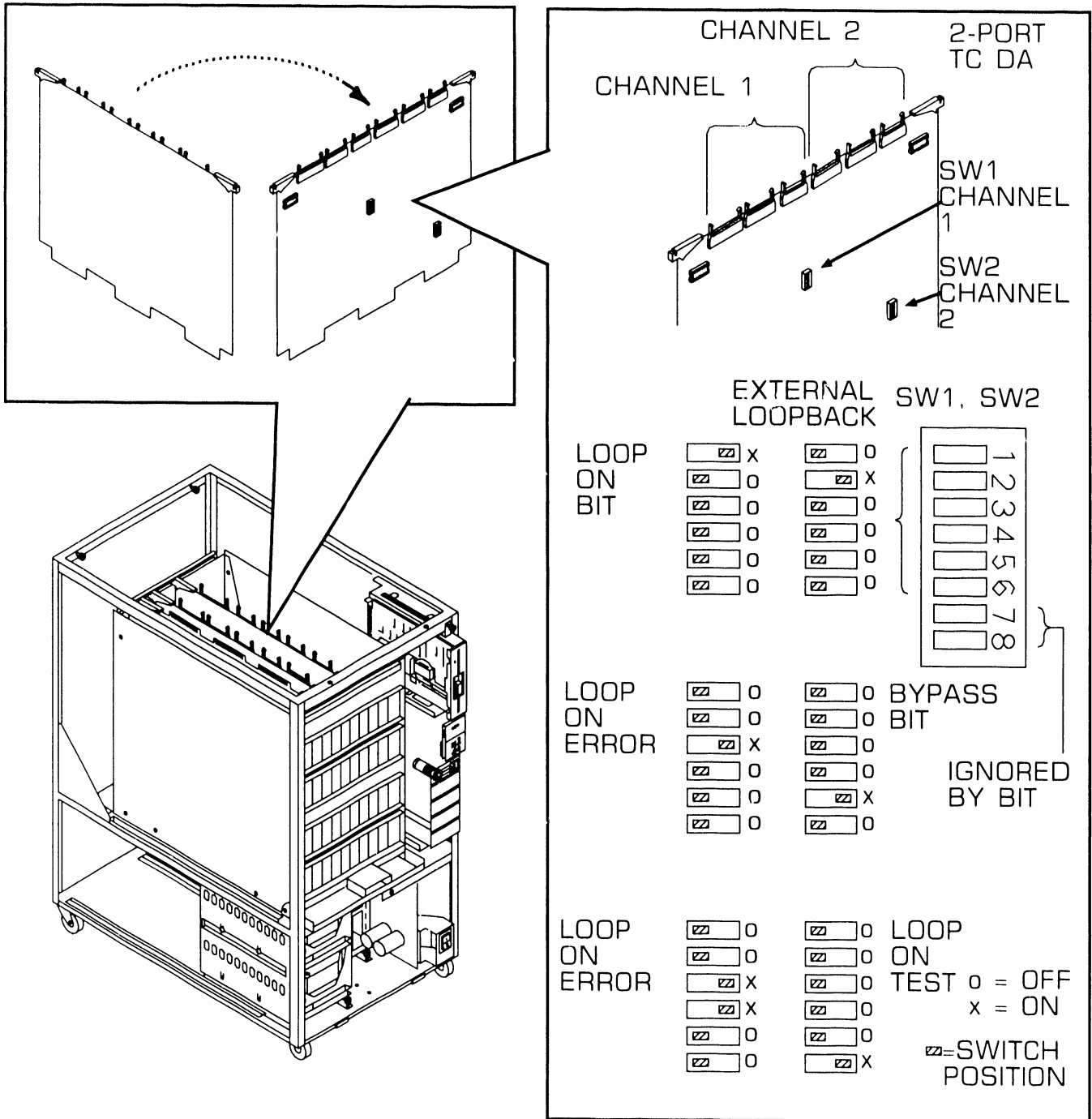

● END

6.2 Power-Up BIT Diagnostics

6.2.5 UISIO Controller Power-Up BIT Diagnostics

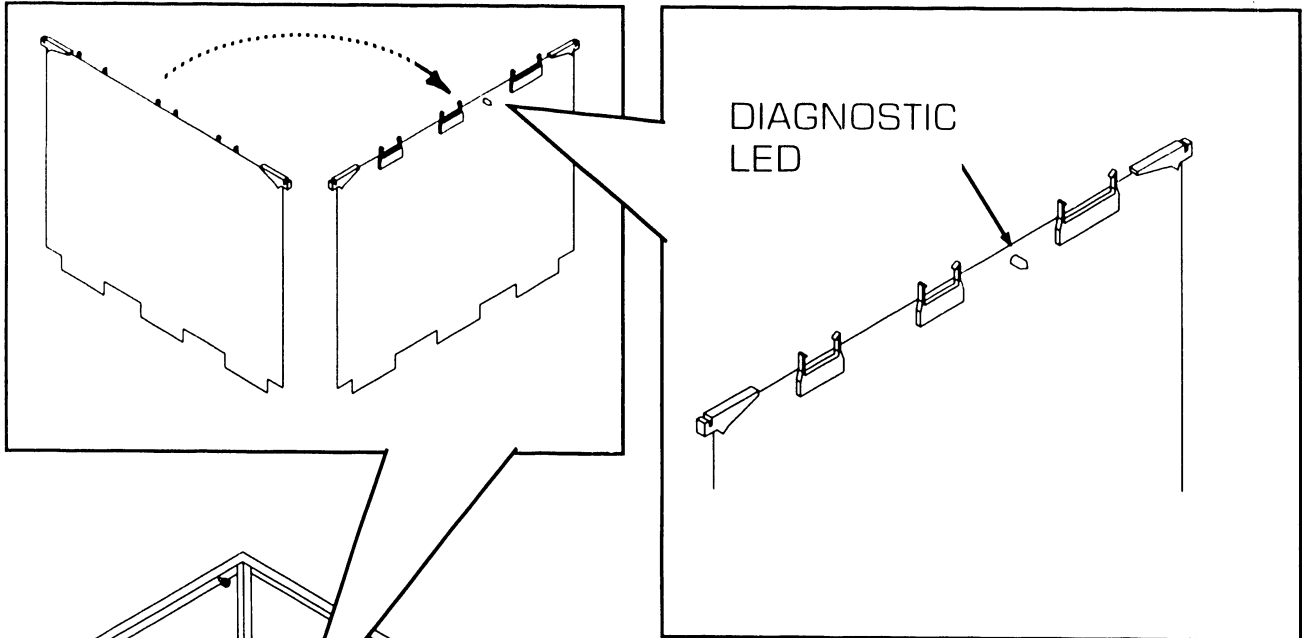

UISIO (Universal Intelligent Serial Input/Output) Controller runs PROM-based power-up diagnostics concurrently with the BP power-up diagnostics and completes in about ten seconds. The status of the UISIO diagnostics is indicated by a LED located at the upper center of the PCA. The LED will light during power-up diagnostics and then go out when the diagnostics have been completed successfully. If the LED stays on, the diagnostics have failed and the PCA may be defective.

● END

6.3 Diskette-Based Diagnostics

6.3.1 Self-Test Diagnostics

Self-Test diagnostics are contained on one 1.2MB diskette (BP2ST) and should be available when troubleshooting at the customer's site to aid in isolating system problems. Self-Test diagnostics are required for the Self-Test sequence of CP7E BP2-Class machines.

The 1.2MB Self-Test diagnostics diskette is bootable and contains the Self-Test monitor files as well as a Monitor Table which may be installed on a SMD or SCSI disk, allowing Self-Test diagnostics to run from the bootstrap volume.

Two optional 360KB diskettes containing Self-Test diagnostics are available, MONST and CP7EST. The 360KB diskettes are not bootable and must be loaded (backed up) on a bootable SMD or SCSI drive. "MONST" contains the diagnostic files required for running Self-Test, the Self-Test monitor software, and two common I/O subsystem Self-Test diagnostics. "CP7EST" contains the Self-Test diagnostics required for the Self-Test sequence of the CP7E BP2-Class machines. In order to operate correctly, both "MONST" and "CP7EST" must be loaded on a bootable drive. (►6.3.4)

● END

6.3 Diskette-Based Diagnostics

6.3.2 Diagnostic Monitor Diagnostics

The Small VS BP2 Class System Diagnostic Package (part number 195-5084-0) is designed for testing the Small VS BP2 Class Hardware configurations. Diagnostic Monitor routines are contained on two 1.2MB diskettes (CP7EDA and BP2IOB) and should be available when troubleshooting at the customer's site to aid in isolating system problems.

The two 1.2MB diagnostic monitor diskettes are bootable and contain the diagnostic monitor files for the CP7E BP2-Class machines. The diagnostic monitor can be loaded on a SMD or SCSI disk drive, allowing the diagnostic monitor to run from the bootstrap volume.

An optional 360KB diskette version is available under part number 195-5285-9. Seven optional 360KB diskettes containing the diagnostic monitor are available; CP7D1, CP7D2, CP7EM1, CP7EM2, BP2IO1, BP2IO2, BP2IO3. The 360KB diskettes must be loaded (backed up) on a bootable SMD or SCSI drive. (►6.3.4) The Self-Test files are included under this part number.

● END

6.3 Diskette-Based Diagnostics

6.3.3 CP7E Diagnostic Monitor Routines (Sheet 1 of 2)

NOTE

When running monitor diagnostics, pressing PF8 to Start an Automatic Sequence runs all tests with Burn-In set to 'Yes'.

Test Configuration for 5.25" Double Sided High Density Floppy Disks

<i>No.</i>	<i>Test No.</i>	<i>Test Name</i>	<i>Burn-In</i>
1	CT1100	CP Control Memory Test	Yes
2	CT2100	BP/CP Communications Test	Yes
3	CT3100	Unconditional Branch	Yes
4	CT4100	Conditional Branch, Subroutine	Yes
5	CT5100	MDR, IREG, PMR, Stack	Yes
6	CT6100	Arithmetic, Mult., CC	Yes
7	CT7100	BNM Operations, BR Tests	Yes
8	MT1200	MAR Operations, TRAM	Yes
9	MT2200	Main Memory, Cache Test	Yes
10	MT3200	DF/DN/BNM Operations	Yes
11	BT2200	BP/MM DMA Diag (CP7)	Yes
12	MT4200	CP/BP MM Data Bus Test	Yes
13	MT5200	CP/BP MM Contention/Cache	Yes
14	CX1100	CPU Tester (CP7)	No
15	BX2000	BP/MM DMA Engr Utility	No

►NEXT

6.3 Diskette-Based Diagnostics

TROUBLESHOOTING

6.3.3 CP7E Diagnostic Monitor Routines (Sheet 2 of 2)

Test Configuration for 5.25" Double Sided High Density Floppy Disks

No.	Test No.	Test Name	Burn-In
1	BT3000	BP Floppy Disk Diag	No
2	RT2200	BP SCSI Subsystem Diag	No
3	ST1000	BP 928 Data Link Diag	No
4	BT1200	BP Async Port/RIPL Diag	No
5	DT1000	SMD Disk DA Diag	No
6	HT1000	RSF DA Diagnostics	No
7	UT1000	Universal ISIO DA Diag	No
8	TT1000	TC DA Single Port Diag	No
9	TT2000	TC DA Two Port Diag	No
10	TT3000	Multi-Line TC DA Diag	No
11	ST3000	8 Port RS232 DA Diag	No
12	ST3000	8 Port EADC DA Diag	No
13	BX0000	BP I/O Engr Utility	No
14	BX2000	BP/MM DMA Engr Utility	No

◆ END

TROUBLESHOOTING

6.3 Diskette-Based Diagnostics

6.3.4 Loading Diagnostic Monitor and Self-Test Onto IPL Drive (Sheet 1 of 2)

To install the diagnostic monitor files and Self-Test files onto the external IPL (non-floppy) drive (SCSI Disk drive set for address 6 or SMD drive located on port 0) perform the following:

1.2MB Diskettes

732-6002A	CP7EDA	CP7E Diagnostics
732-6007A	BP2IOB	I/O Diagnostics
732-6008A	BP2ST	Self-Test Diagnostics

NOTE

For single drive systems, DISKINIT 'RELABEL' function must be performed using Stand-Alone Utilities. (►9.9.4)

- 1 BP SW1 switches 5 - 8 must be in the normal power-up position. (►7.2.7)
- 2 BACKUP Library @DIAGMN@, @DIAGST@, and @SYSTEM@ from the appropriate diskettes listed below to the target drive (SCSI disk drive set for address ID 6 or external SMD drive). Specify 'CLEAR = NO' when Backup utility requests the Output Volume. Specify 'UPDATE' when backup utility queries as to how to handle duplicate files.

►NEXT

6.3 Diskette-Based Diagnostics

6.3.4 Loading Diagnostic Monitor and Self-Test Onto IPL Drive (Sheet 2 of 2)

360KB Diskettes

732-8078A	CP7D1	CP7 Basic
732-8079A	CP7D2	CP Advanced
732-8115A	CP7EM1	CP/MM
732-8116A	CP7EM2	CP/BP/MM
732-8112A	BP2IO1	I/O System
732-8113A	BP2IO2	I/O System
732-8110A	BP2IO3	I/O System
732-8111A	MONST	S/T Monitor
732-8107A	CP7EST	S/T for CP7E

5 Run DISKINIT and perform the RELABEL function on the target disk (disk may be renamed the same volume name).

6 The installation is complete.

3 After backing up library @DIAGMN@, @DIAGST@, and @SYSTEM@ from all the appropriate diskettes, scratch file @MONTBL@ in library @DIAGMN@ on the target disk.

4 Rename file @MONTBLM in library @DIAGMN@ on the target disk to @MONTBL@.

● END

6.3 Diskette-Based Diagnostics

6.3.5 Running Diagnostic Monitor From Bootstrap Volume (Sheet 1 of 5)

Diagnostics monitor should be used when:

- The system is a new installation.
- A fatal error occurs while running Self-Test Diagnostics.
- A non-fatal error occurs and the error code indicated is unclear.

Accessing Diagnostic Monitor can be accomplished:

- During normal power-on procedures by pressing the PF8 key (if loaded on IPL drive). (▶ 6.3.3)
- IPLing directly from one of the 1.2MB diagnostics diskettes.

▶NEXT

6.3 Diskette-Based Diagnostics

TROUBLESHOOTING

6.3.5 Running Diagnostic Monitor From Bootstrap Volume (Sheet 2 of 5)

- 1 Position the Local/Remote Keyswitch in the local position.
- 2 Select boot device by positioning Boot Device Switch to appropriate position. (If floppy is selected, insert the 1.2MB diagnostic diskette 'CP7EDA' in floppy drive and close latch.)
- 3 Power-on mainframe. Press front panel 'Control Mode' pushbutton, then 'Initialize' pushbutton. The Hex display will begin count down from Hex FFFF.
- 4 In about 45 seconds, the Small VS BP2 Class Self Test Package IPL Drive Selection screen will be displayed on WSO.
- 4 The cursor will be positioned next to the bootstrap volume (2270V7 when booted from the floppy). Position cursor next to device diagnostic monitor is to be run from and press PF8. The VS Diagnostic Monitor Disclaimer screen will be displayed.

Small VS BP2 Class Self Test Package Version R2xxx
IPL Drive Selection
Bootstrap Volume = CP7EDA

Device	Capacity	Type	Volume	Status
2270V7	1.2 Mb	Dsket		
■ 2269V4	142 Mb	Dsket	SYSTEM	Crash Tolerant
2269V4	142 Mb	Dsket	DATA	Crash Tolerant

Position Cursor to Indicated Device and Select:

(ENTER)Test & IPL (PF1)IPL Only (PF8)Stand-Alone Diagnostic Monitor

►NEXT

6.3 Diskette-Based Diagnostics

6.3.5 Running Diagnostic Monitor From Bootstrap Volume (Sheet 3 of 5)

5 The Disclaimer Screen will inform the user the Advanced Diagnostic Package was selected and that running this package is at their own risk. At this time, the user has the option of running the diagnostic monitor tests or returning to the Self Test Package Screen by pressing PF16.

6 The Diagnostic Monitor has two modes of operation; Customer Runnable Mode and Customer Engineer Mode.

Customer Runnable Mode

Customer Runnable Mode is selected by entering 'YES' (either upper or lower case) in the fill-in field and pressing RETURN. This mode contains a limited number of non-destructive tests the customer can run. The PF keys descriptors are disabled with the exception of PF16, which returns the user to the Self-Test Package screen.

VS Diagnostic Monitor Package

----- NOTICE -----

This diagnostic package is the property of Wang Laboratories, Inc., and is provided for the use by authorized personnel only. Improper use may cause loss or damage to programs and/or data. This package and related materials may not be disclosed or otherwise made available to third parties without the prior permission of Wang.

In no event shall Wang Laboratories, Inc., or its subsidiaries be liable for incidental or consequential damages in connection with or arising from the use of the diagnostic package, the accompanying manual, or any related materials.

Enter YES to Acknowledge, PF16 to Exit



▶NEXT

6.3

TROUBLESHOOTING

Diskette-Based Diagnostics

6.3.5 Running Diagnostic Monitor From Bootstrap Volume (Sheet 4 of 5)

Customer Engineer Mode

Customer Engineer Mode is selected by entering 'CSG' (upper case dependent) in the fill-in field and pressing RETURN. This mode contains all the diagnostic tests as previously described for the diskette loaded. PF keys descriptors are enabled.

- 7 Enter 'CSG' in the fill-in field and press RETURN.

The Program Selection Menu will be displayed.

NOTE

The screen load displayed will be loaded from the SCSI/SMD drive. When loaded from the floppy drive, the tests listed for the diskette will be displayed. (▶6.3.3).

Small VS BP2 Class Monitor Package Version R2xxx
Test Selection Option

To Select Tests, Position Cursor and Press any NON-BLANK key. Press SPACE or DELETE to Deselect a Test. Press PF8 to Start An Automatic Sequence. Press ENTER to Begin Testing. Press PF16 to Terminate.

Test Name	Test Name
■ 1 CP Control Memory Test	■ 16 BP SCSI Subsystem Diag
■ 2 BP/CP Communication Test	■ 17 BP 928 Data Link Diag
■ 3 Unconditional Branch	■ 18 BP Async Port/RIPL Diag
■ 4 Cond. Branch, Subroutine	■ 19 SMD Disk DA Diag
■ 5 MDR, IREG, PMR, Stack	■ 20 RSF DA Diag
■ 6 Arithmetic, Mult., CC	■ 21 Universal ISIO DA Diag
■ 7 BNM Operations, BR Tests	■ 22 1 Port TC DA Diag
■ 8 MAR Operations, TRAM	■ 23 2 Port TC DA Diag
■ 9 Main Memory, Cache Test	■ 24 Multi-Line TC DA Diag
■ 10 OF/DN/BNM Operations	■ 25 8 Port RS232 DA Diag
■ 11 BP,MM DMA Diag (CP7)	■ 26 8 Port EADC DA Diag
■ 12 CP/BP MM Data Bus Test	■ 27 BP I/O Engr Utility
■ 13 CP/BP MM Contention/Cache	■ 28 BP/MM DMA Engr Utility
■ 14 CPU Tester (CP7)	
■ 15 BP Floppy Disk Diag	

▶NEXT

6.3 Diskette-Based Diagnostics

6.3.5 Running Diagnostic Monitor From Bootstrap Volume (Sheet 5 of 5)

- 8 Select the tests to be run and press ENTER to begin testing or press PF8 to begin the automatic sequence. Run diagnostics for one complete, error free pass. The Run-Time screen will be displayed.
- 9 For floppy loaded diagnostic monitor test, remove CP7EDA diskette from the floppy drive and insert diskette BP210. Press Initialize. When the Small VS BP2 Class Self Test Package Screen appears on WSO, press PF8 to select the Diagnostic Monitor. Enter 'CSG' to acknowledge the disclaimer screen.
- 10 Select the tests to be run and press ENTER. Run the diagnostics for one complete, error free pass.
- 11 If an error occurs, display the Diagnostic Monitor Error Log at the end of one complete pass (►6.3.5.3). This is accomplished by pressing the PF13 key.
- 12 If no error is detected, press the PF16 key to return to the Diagnostic Monitor Program Selection screen. Press PF16 again to terminate and return to the IPL Drive Selection screen.
- 13 Select the desired disk drive and press ENTER to IPL and Self-Test or PF1 to IPL only and complete the system IPL sequence.

CAUTION

EXERCISE EXTREME CAUTION WHEN ATTEMPTING TO USE BP210 DISKETTE. THE ABILITY TO WRITE TO ANY DISK ATTACHED TO THE SYSTEM IS MADE AVAILABLE. VALUABLE CUSTOMER DATA MAY BE DAMAGED.

● END

6.3

TROUBLESHOOTING

Diskette-Based Diagnostics

6.3.5.1 Running Selected Monitor Diagnostics

Select the diagnostics to be run by positioning the cursor next to the test desired and press any Non-Blank character key. This can be accomplished by using either the Up/Down arrow keys or the TAB key.

Deselect tests by positioning the cursor next to the test to be deselected and press the SPACE Bar.

Once the test are selected, press ENTER to display the Run-Time menu and to start the diagnostic tests in the order selected. If testing is not altered by the operator or by hardware failure, the monitor automatically cycles on the set of selected diagnostic programs.

◆ END

6.3 Diskette-Based Diagnostics

TROUBLESHOOTING

6.3.5.2 Run-Time Menu Screen Commands And Descriptors (sheet 1 of 3)

Run-Time Screen contains nine commands and eight descriptors. The operator uses the Run-Time screen to monitor test results and the PF function key commands (a description of the commands are contained in paragraph 6.5.5.1) and alternate action commands to control test performance. Selecting the commands initiates the functioning of the command and places an asterisk (*) in the appropriate pseudo space on the screen. The next time the command is selected, it becomes an alternate action command and will cause the original command to be deselected.

NOTE

Fields 'Error Code, Error Count, Routine Loop Count, and Program Loop Count' are displayed only when an error occurs and/or when Loop Count Routine and Program Loop Count are selected.

The current diagnostic program writes error messages and prompts in the lower half of the screen. If more than one error occurs, only the last error message will be displayed, although the error count and the Diagnostic Monitor Error Log are updated for each error.

Small VS BP2 Class Monitor Package Version R2xxx

**** **** **** ****

Program Name: R1610ADPCP7 Cntrl Mem Diag	Error Count:	= 00000
Routine Name:	Routine Loop Count	= 00000
Error Code	Program Loop Count	= 00000
Program Status: Test in Progress	Monitor Pass Count	= 00002

Messages:

➡NEXT

6.3 Diskette-Based Diagnostics

6.3.5.2 Run-Time Menu Screen Commands And Descriptors (sheet 2 of 3)

The pseudo spaces are defined as follows:

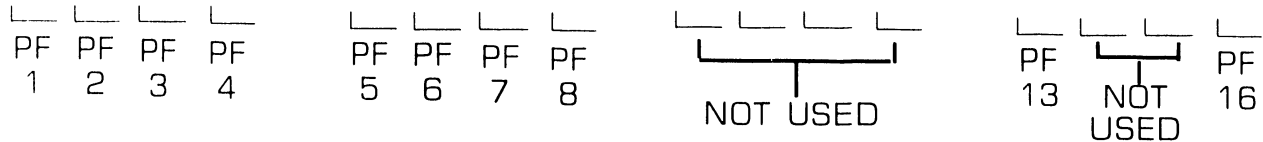

<i>Key</i>	<i>Command</i>	<i>Description</i>
PF1	Error Loop	Loop on routine in which the next failure occurs.
PF2	Routine Loop	Loop on current test routine.
PF3	Stop On Error	Stop the program when the next failure is detected.
PF4	Loop On Program	Loop on current diagnostic program.
PF5	Pause	Halt program prior to the next test routine.
PF6	Scope Loop	Loop on next test routine in which hardware failure occurs. Identical to ERROR LOOP except that error reporting is omitted after the first error.
PF7	Step	Used to step pass a selected option (PF1-PF5). That is a STEP through PAUSE, Program or Routine Loop, or STOP-ON-ERROR without deselecting the command.
PF8	Clear All Settings	Resets all other test control commands.
PF13	Display Error Log	Displays the 23 most recent errors in error buffer. Pressing ENTER returns the user to the Run-Time Menu with no effect on the error log buffer.
PF16	Exit	Terminates the Diagnostic Monitor program and the Test selection screen is re-entered.

➡NEXT

6.3

Diskette-Based Diagnostics

TROUBLESHOOTING

6.3.5.2 Run-Time Menu Screen Commands And Descriptors (sheet 3 of 3)

<i>Descriptor</i>	<i>Description</i>
PROGRAM NAME	The name of the program currently being executed. A program name consists of one or more test routines.
ROUTINE NAME	The name of the test routine currently being executed.
ERROR CODE	The code of the most recently detected error.
PROGRAM STATUS	The status of the diagnostic currently being performed. (e.g. TEST-IN-PROGRESS, STOP ON ERROR, PROGRAM PAUSE, STEP, etc.).
ERROR COUNT	A decimal count of the number of errors which have been detected. The count is cumulative and is reset only by re-IPLing or returning to Program Selection Menu (PF16).
ROUTINE LOOP COUNT	A decimal count of the number of loops which have been made through the diagnostic routine currently being performed. This value is only displayed when LOOP-ON-ROUTINE is in effect. It is cleared when the LOOP-ON-ROUTINE option is deselected.
PROGRAM LOOP COUNT	Identical to Routine Loop Count with the exception that this count applies to diagnostic programs rather than to routines.
MONITOR PASS COUNT	A decimal count of the number of loops which have been made through a set of diagnostic programs. Cleared by re-IPLing or returning to Program Selection Menu (PF16).

● END

TROUBLESHOOTING

6.3 Diskette-Based Diagnostics

6.3.5.3 Interpreting the Diagnostic Monitor Error Log (Sheet 1 of 2)

Display the Diagnostic Monitor Error Log by pressing PF13 key. This log contains up to 23 of the most recent errors. The errors are listed as 8-character codes followed by up to 18 Hex characters.

The first two characters identifies the PCA (or unit) being tested and the program, routine, or error notation. The second two characters (hex notation) identify the program number, the third two characters (hex notation) identify the test routine within the program, the fourth two characters (hex notation) identify the error within the routine, and the remaining 18 characters (hex notation) contain the error message code.

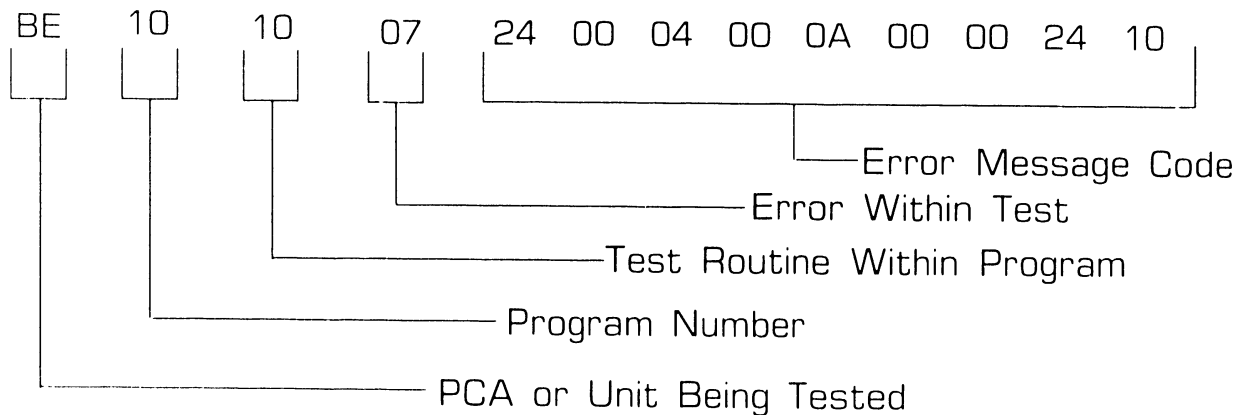

➡NEXT

TROUBLESHOOTING

6.3 Diskette-Based Diagnostics

6.3.5.3 Interpreting the Diagnostic Monitor Error Log (Sheet 2 of 2)

To decipher the failing unit, observe the first error code character contained in the last entry of the error log. For the example, the error code is BE101007 24 00 04 00 0A 00 00 00 24 10. Using the table below, compare the first error code character (in this example 'B', Bus Processor) to the table to find the failing unit.

<i>First Error Character Code</i>	<i>Failing Unit</i>
B	Bus Processor DA
C	Central Processor Device Adapter PCA
D	Internal Fixed or External Disk Drive and/or DA
M	Main Memory and Cache Memory Device Adapter PCA
S	Serial I/O (SIO/ISIO/UISIO [928]) PCA or WSO
T	Telecommunications Device Adapter PCA

● END

6.3 Diskette-Based Diagnostics

6.3.6 Running Self-Test Diagnostic

Self-Test Diagnostic (STD) software is always loaded from the selected IPL volume. The STD software is loaded into the BP's Code RAM (CRAM) from library @DIAGST@. It verifies all logic necessary to IPL the system; CP Control Memory; data path to BP, instructions, status bits CP/Cache/Main Memory communication, Dual Processor functionality, and the BP's ability to communicate with WS-0 are tested.

The STD software are run from the BP2 Class Self Test Package - IPL Drive Selection Screen by pressing the 'ENTER' key (▶4.2). The STD is maintained in library @DIAGST@ on the system default disk drive (if loaded) and on the stand-alone bootable Self-Test Diagnostic diskette.

If an error is detected, the error codes will be displayed on the Front Panel HEX display and on WS-0 screen (▶6.4.4). When no error is detected, the STD will complete its testing in about one minute per megabyte of memory, and then will begin system IPL. The system must pass the Self-Test Diagnostic programs for IPL to begin.

● END

6.4 TROUBLESHOOTING

6.4 Error Codes and Descriptions

6.4.1 BP2 Class Microcode Error/Status Codes And Description (Sheet 1 of 6)

BP2 Class Error Code Analysis

<i>Error Code</i>	<i>Test/Error Description</i>
-------------------	-------------------------------

BP OS Generated Error/Status Codes

0002	Divide Exception
0003	Invalid Task Reference
0004	Invalid Semaphore Use
0005	Invalid Priority
0006	No More Memory
0007	Unexpected Error
0008	Invalid Sender
0009	Wild Branch

SCSI Error Codes

0030	Invalid Command
0031	Invalid Count
0032	Invalid Address
0033	Invalid Device Address
0034	Data Compare Error
0035	Parity Error
0036	Addressing Error
0037	DMA Timeout
0038	Hardware Error
0039	Invalid State Error
003A	Check Error
003B	Disconnect Error
003C	Select Timeout
003D	Reselect Timeout
003E	Not Used
003F	ISR Error

◆NEXT

6.4 TROUBLESHOOTING

6.4 Error Codes and Descriptions

6.4.1 BP2 Class Microcode Error/Status Codes And Description (Sheet 2 of 6)

BP2 Class Error Code Analysis

<i>Error Code</i>	<i>Test/Error Description</i>
25V36 (DE) Generated Error Codes	
0040	Undefined Error
0041	The DA has made a request of the BP that is not valid under the current context
0042	The DA is not considered to be running by the BP and therefore the receive IOCW can not be processed
0043	The transfer of the request from the DA to the BP failed to complete
0044	The transfer of the IOCW from the BP to the DA failed to complete
0045	There was no response (request) from DA to begin processing the outstanding IOCW
0046	The DA has specified an invalid address in the requested transfer
0047	The DA has requested a transfer which exceeds the top of its memory
0048	The DA has requested the transfer of more data than specified in the IOCW
0049	The DA has not gone ready after being reset within the given amount of time
004A	A parity error has occurred on a BP/DA interface
004B	An addressing error has occurred on a transfer involving main memory
004C	A parity error has occurred on a transfer involving main memory
004D	The IOCW received is invalid
004E	The DRT received is invalid
004F	A parity error has occurred on the DA during a transfer between MM and the DA

►NEXT

6.4 Error Codes and Descriptions

6.4.1 BP2 Class Microcode Error/Status Codes And Description (Sheet 3 of 6)

BP2 Class Error Code Analysis

<i>Error Code</i>	<i>Test/Error Description</i>
25V96 MLTC Generated Error Codes	
0050	Invalid DTR
0051	DA not running
0052	Memory address used is not 32-bit aligned, or entries in IAL are not 2K aligned
0053	Hardware detected parity error on last DMA
0054	Hardware detected an addressing error on last DMA
0055	IOCW received is not supported or invalid
0056	A quit request has been received from the DA indicating the DA no longer running and must be reloaded/restarted
0057	DMA timeout, hardware detected parity error or addressing error
0058	DA request is invalid
0059	DA could not be reset
005A	DA RAM address in the DA request is invalid
005B	DA RAM address and the data count exceeds top of DA RAM
005C	DA is requesting the transfer of more data than specified
005D	DMA of data between DA and Main Memory Failed
005E	DA has not made request to execute the previously issued command within a reasonable amount of time
005F	DA has indicated via its status register that a hardware failure on the DA has occurred

►NEXT

6.4 TROUBLESHOOTING

6.4 Error Codes and Descriptions

6.4.1 BP2 Class Microcode Error/Status Codes And Description (Sheet 4 of 6)

BP2 Class Error Code Analysis

<i>Error Code</i>	<i>Test/Error Description</i>
22V76-1 And 27V76-2 (TC) Generated Error Codes	
0060	No DCT has been loaded prior to receiving a SIO or Load Code. A load DCT CIO must be the 1st IOCW sent to the DA after powerup
0061	A IOCW was received that requires the DA to be running to process it, but the DA is not running
0062	The MM address to be used in the next MM DA is not 32-bit (VS word) aligned, or entries in the IAL are not 2K aligned
0063	The hardware has detected a parity error on the last DMA
0064	The hardware has detected an addressing error on the last DMA
0065	The IOCW received is not supported or not valid in current program
0066	A Quit request has been received from the DA indicating the DA is no longer running and must be reloaded/restarted
0067	The DMA of the CMD from the BP to the DA failed. (DMA timeout, hardware detected parity or addressing error)
0068	The DA request is not valid in the current program text
0069	The IOCW specified a DMA transfer out of main memory while the DA requested a transfer into main memory
006A	The DA RAM address in the DA request is invalid
006B	The DA RAM address plus data count exceeds the top of the DA's RAM
006C	The DA is requesting the transfer of more data than specified in the IOCW
006D	The DMA of data between the DA and main memory failed (DMA timeout, hardware detecting parity or address error)
006E	The DA has not made a request to execute the previously issued CMD within a reasonable amount of time
006F	The DA has indicated via its status register that a hardware failure has occurred

►NEXT

6.4 TROUBLESHOOTING

6.4 Error Codes and Descriptions

6.4.1 BP2 Class Microcode Error/Status Codes And Description (Sheet 5 of 6)

BP2 Class Error Code Analysis

<i>Error Code</i>	<i>Test/Error Description</i>
-------------------	-------------------------------

25V37, 25V67 (ISIO, UISIO) Generated Error Codes (Control Mode)

0070	Undefined Error
0071	BP Parity Error
0072	Unknown Command received from device
0073	WS Code failed to be loaded
0074	DA Code failed to be loaded
0075	DA Response Command time out
0076	Protocol Error
0077	Main Memory ECC Error
0078	Main Memory Address Error

25V37, 25V67 (ISIO, UISIO) LED Error Codes (Non-Control Mode)

0080	Undefined Error
0081	A request was received from the DA which is invalid under the current program
0082	An IOCW was received that requires DA to be running to complete processing but the DA is not running
0082	A Quit request was received by the task from the DA. Outstanding I/O is error completed and IT Msgs are sent to all other tasks on the same DA notifying them to error complete any outstanding I/O they may have
0082	Notifies task it's DA is not running and to error complete outstanding I/O
0083	The DMA of CMD/data from the BP to the DA timed out or a parity error was detected during the transfer
0084	The DMA of data between Main memory and the DA timed out, or a parity error occurred during the transfer

◆NEXT

6.4 TROUBLESHOOTING

6.4 Error Codes and Descriptions

6.4.1 BP2 Class Microcode Error/Status Codes And Description (Sheet 6 of 6)

BP2 Class Error Code Analysis

<i>Error Code</i>	<i>Test/Error Description</i>
25V37, 25V67 (ISIO, UISIO) LED Error Codes (Non-Control Mode) (Cont.)	
0085	A CMD was issued to the DA and DA did not respond with the appropriate request within the given amount of time
0088	The length of the transfer requested by the DA extended past the starting Main Memory Address plus the count specified in the IOCW.
0089	After the DA hardware was reset via an out issued by the BP, the hardware ready status bit was not set by hardware within the given amount of time
008A	BP parity error detected
008B	The Source/destination address alignment for the requested DMA transfer is invalid, or an IAL entry is invalid
008C	A parity error was detected on the DMA transfer to/from Main Memory
008D	The CMD specified in the IOCW is not supported, or a parameter within the IOCW is out of range
008E	The Drt length specified in the IOCW is not 1024
25V27 (DSIO) Generated Error Codes	
0091	More than 2 tape devices attached on a DSIO (only the last 2 will operate in extended MSEM mode)
Crash Task Generated Error Codes	
0093	A BP task has crashed
Floppy Task Generated Error Codes	
0095	The floppy disk controller chip could not be reset

● END

6.4 TROUBLESHOOTING

6.4 Error Codes and Descriptions

6.4.2 BP2 Class System Error/Status Codes And Description

BP2 Class System Error Code Analysis

<i>Error Code</i>	<i>Test/Error Description</i>
00E0	Unable to load code to workstation 0. (Power the workstation off and on to attempt to clear the condition)
00E1	Main Memory parity error occurred during a CODE RAM DAM
00E2	Main Memory DMA attempted to access a non-existent address
00E3	BP DATA RAM parity error has occurred
00E4	PDA of IPL disk (passed from diagnostics) not found in PDA table
00E5	A Pascal exception of unknown origin has occurred
00E6	An invalid device adapter type value has been detected
00E7	DMA operation between DATA RAM and Main Memory timed out
00E8	The CP set an illegal command out area code
00E9	Repeated DMA attempts for the command out area failed, BP initiates entry into control mode
00EA	Repeated DMA attempts for the processor interrupt area failed, BP initiates entry into control mode
00EB	A SIO/CIO raced with an EC or NC IOSW (possible OS failure), BP initiates entry into control mode
00EC	An IRQ/DAR raced with an EC or NC IOSW (possible OS failure), BP initiates entry into control mode
00ED	Main Memory error correction count exceeds its limit (i.e. 1), BP initiates entry into control mode
00EE	File not found (Control Mode)
00EF	Library not found (Control Mode)
00F0	Device not found (Control Mode)
00F1	File not open (Control Mode)
00F2	VTOC Error (Control Mode)
00F3	End of file (Control Mode)
00F4	IPL device returned damage status (Control Mode)
00F5	IPL device was not-ready - intervention required (Control Mode)
00F6	BP memory or disk address error while accessing IPL device (Control Mode)
00F7	File error in getting control mode pointers

● END

6.4 TROUBLESHOOTING

6.4 Error Codes and Descriptions

6.4.3 BP2 Class Diagnostic Monitor Error Codes And Description (Sheet 1 of 17)

BP2 Class Diagnostic Monitor Error Code Analysis

Error Code	Test/Error Description	Comments
41	Bootstrap Loader (@MCBOOT@)	
4110	Unlabeled Volume (VOL1 Missing)	
4111	Media Error Label	Volume Label
4112	Controller Hardware Error	Volume Label
4114	Drive Not Ready	Volume Label
4116	Program Error (Divide)	Volume Label
4118	Program Error (Data)	Volume Label
4119	Media Error	Bit Map
411A	Controller Hardware Error	Bit Map
411C	Drive Not Ready	Bit Map
411E	Program Error (Divide)	Bit Map
4120	Program Error (Data)	Bit Map
4121	Media Error	VTOC
4122	Controller Hardware Error	VTOC
4124	Drive Not Ready	VTOC
4126	Program Error (Divide)	VTOC
4128	Program Error (Data)	VTOC
412A	FDX1 ID Does Not Match	VTOC
412B	FDX2 ID Does Not Match	VTOC
412C	FDR1 ID Does Not Match	VTOC
Self-Test Monitor = @NORMAL@ in @DIAGST@		
4131	Media Error	Self Test Monitor
4132	Controller Hardware Error	Self Test Monitor
4133	Checksum Does Not Match	Self Test Monitor
4134	Drive Not Ready	Self Test Monitor
4136	Program Error (Divide)	Self Test Monitor
4138	Program Error (Data)	Self Test Monitor
413A	Library Not Found	Self Test Monitor
413B	File Not Found	Self Test Monitor
413C	FDR1 Not Found	Self Test Monitor
413E	Extents Greater Than 3	Self Test Monitor

►NEXT

6.4 TROUBLESHOOTING

6.4 Error Codes and Descriptions

6.4.3 BP2 Class Diagnostic Monitor Error Codes And Description (Sheet 2 of 17)

BP2 Class Diagnostic Monitor Error Code Analysis

<i>Error Code</i>	<i>Test/Error Description</i>	<i>Comments</i>
Diagnostic Monitor = @MONITOR in @DIAGMN@		
4141	Media Error	Diagnostic Monitor
4142	Controller Hardware Error	Diagnostic Monitor
4143	Checksum Does Not Match	Diagnostic Monitor
4144	Drive Not Ready	Diagnostic Monitor
4146	Program Error (Divide)	Diagnostic Monitor
4148	Program Error (Data)	Diagnostic Monitor
414A	Library Not Found	Diagnostic Monitor
414B	File Not Found	Diagnostic Monitor
414C	FDR1 Not Found	Diagnostic Monitor
414E	Extents Greater Than 3	Diagnostic Monitor
System Loader = @MCIPL@ in @SYSTEM@		
4151	Media Error	System Loader
4152	Controller Hardware Error	System Loader
4153	Checksum Does Not Match	System Loader
4154	Drive Not Ready	System Loader
4156	Program Error (Divide)	System Loader
4158	Program Error (Data)	System Loader
415A	Library Not Found	System Loader
415B	File Not Found	System Loader
415C	FDR1 Not Found	System Loader
415E	Extents Greater Than 3	System Loader
41F3	Invalid Hardware Configuration	
41F4	Floppy Status Error	
41FD	BP RAM Parity Error	
41FE	BP RAM Parity Error	
41FF	Unknown Interrupt on BP	

►NEXT

6.4 Error Codes and Descriptions

6.4.3 BP2 Class Diagnostic Monitor Error Codes And Description (Sheet 3 of 17)

BP2 Class Diagnostic Monitor Error Code Analysis

Error Code	Test/Error Description	Comments
42	Self-Test Monitor (@NORMAL@ in @DIAGST@)	
420F	Incompatible Version of Self-Test Code	
4210	Unlabeled Volume (VOL1 Missing)	
4211	Media Error	Volume Label
4212	Controller Hardware Error	Volume label
4214	Drive Not Ready	Volume label
4216	Program Error (Divide)	Volume label
4218	Program Error (Data)	Volume label
4219	Media Error	Bit Map
421A	Controller Hardware Error	Bit Map
421C	Drive Not Ready	Bit Map
421E	Program Error (Divide)	Bit Map
4220	Program Error (Data)	Bit Map
4221	Media Error	VTOC
4222	Controller Hardware Error	VTOC
4224	Drive Not Ready	VTOC
4226	Program Error (Divide)	VTOC
4228	Program Error (Data)	VTOC
422A	FDX1 ID Does Not Match	VTOC
422B	FDX2 ID Does Not Match	VTOC
422C	FDR1 ID Does Not Match	VTOC
	Workstation File = @MONISIO@ in @DIAGST@ (SIO)	
4231	Media Error	Workstation File
4232	Controller Hardware Error	Workstation File
4233	Checksum Does Not Match	Workstation File
4234	Drive Not Ready	Workstation File
4236	Program Error (Divide)	Workstation File
4238	Program Error (Data)	Workstation File
423A	Library Not Found	Workstation File
423B	File Not Found	Workstation File
423C	FDR1 Not Found	Workstation File
423E	Extents Greater Than 3	Workstation File

►NEXT

6.4 TROUBLESHOOTING

6.4 Error Codes and Descriptions

6.4.3 BP2 Class Diagnostic Monitor Error Codes And Description (Sheet 4 of 17)

BP2 Class Diagnostic Monitor Error Code Analysis

<i>Error Code</i>	<i>Test/Error Description</i>	<i>Comments</i>
Workstation File = @MONISIO@ in @DIAGST@ (USIO)		
4241	Media Error	Workstation File
4242	Controller Hardware Error	Workstation File
4243	Checksum Does Not Match	Workstation File
4244	Drive Not Ready	Workstation File
4246	Program Error (Divide)	Workstation File
4248	Program Error (Data)	Workstation File
424A	Library Not Found	Workstation File
424B	File Not Found	Workstation File
424C	FDR1 Not Found	Workstation File
424E	Extents Greater Than 3	Workstation File
42 Self-Test Diag. Test 2 = @BT0500@ in @DIAGST@		
4261	Media Error	Diagnostic Test 2
4262	Controller Hardware Error	Diagnostic Test 2
4263	Checksum Does Not Match	Diagnostic Test 2
4264	Drive Not Ready	Diagnostic Test 2
4266	Program Error (Divide)	Diagnostic Test 2
4268	Program Error (Data)	Diagnostic Test 2
426A	Library Not Found	Diagnostic Test 2
426B	File Not Found	Diagnostic Test 2
426C	FDR1 Not Found	Diagnostic Test 2
426E	Extents Greater Than 3	Diagnostic Test 2

►NEXT

6.4 Error Codes and Descriptions

6.4.3 BP2 Class Diagnostic Monitor Error Codes And Description (Sheet 5 of 17)

BP2 Class Diagnostic Monitor Error Code Analysis

<i>Error Code</i>	<i>Test/Error Description</i>	<i>Comments</i>
Self-Test Diag. Test 3 = @CT0500@/@CT0100@ in @DIAGST@		
4271	Media Error	Diagnostic Test 3
4272	Controller Hardware Error	Diagnostic Test 3
4273	Checksum Does Not Match	Diagnostic Test 3
4274	Drive Not Ready	Diagnostic Test 3
4276	Program Error (Divide)	Diagnostic Test 3
4278	Program Error (Data)	Diagnostic Test 3
427A	Library Not Found	Diagnostic Test 3
427B	File Not Found	Diagnostic Test 3
427C	FDR1 Not Found	Diagnostic Test 3
427E	Extents Greater Than 3	Diagnostic Test 3
Self-Test Diag. Test 4 = @CT0800@/@CT0200@ in @DIAGST@		
4281	Media Error	Diagnostic Test 4
4282	Controller Hardware Error	Diagnostic Test 4
4283	Checksum Does Not Match	Diagnostic Test 4
4284	Drive Not Ready	Diagnostic Test 4
4286	Program Error (Divide)	Diagnostic Test 4
4288	Program Error (Data)	Diagnostic Test 4
428A	Library Not Found	Diagnostic Test 4
428B	File Not Found	Diagnostic Test 4
428C	FDR1 Not Found	Diagnostic Test 4
428E	Extents Greater Than 3	Diagnostic Test 4

►NEXT

6.4 Error Codes and Descriptions

6.4.3 BP2 Class Diagnostic Monitor Error Codes And Description (Sheet 6 of 17)

BP2 Class Diagnostic Monitor Error Code Analysis

<i>Error Code</i>	<i>Test/Error Description</i>	<i>Comments</i>
Self-Test Diag. Test 5 = @CT0B00@/@CT0300@ in @DIAGST@		
4291	Media Error	Diagnostic Test 5
4292	Controller Hardware Error	Diagnostic Test 5
4293	Checksum Does Not Match	Diagnostic Test 5
4294	Drive Not Ready	Diagnostic Test 5
4296	Program Error (Divide)	Diagnostic Test 5
4298	Program Error (Data)	Diagnostic Test 5
429A	Library Not Found	Diagnostic Test 5
429B	File Not Found	Diagnostic Test 5
429C	FDR1 Not Found	Diagnostic Test 5
429E	Extents Greater Than 3	Diagnostic Test 5
Self-Test Diag. Test 6 = @MT0500@/@MT0100@ in @DIAGST@		
42A1	Media Error	Diagnostic Test 6
42A2	Controller Hardware Error	Diagnostic Test 6
42A3	Checksum Does Not Match	Diagnostic Test 6
42A4	Drive Not Ready	Diagnostic Test 6
42A6	Program Error (Divide)	Diagnostic Test 6
42A8	Program Error (Data)	Diagnostic Test 6
42AA	Library Not Found	Diagnostic Test 6
42AB	File Not Found	Diagnostic Test 6
42AC	FDR1 Not Found	Diagnostic Test 6
42AE	Extents Greater Than 3	Diagnostic Test 6

►NEXT

6.4 TROUBLESHOOTING

6.4 Error Codes and Descriptions

6.4.3 BP2 Class Diagnostic Monitor Error Codes And Description (Sheet 7 of 17)

BP2 Class Diagnostic Monitor Error Code Analysis

<i>Error Code</i>	<i>Test/Error Description</i>	<i>Comments</i>
Self-Test Diag. Test 7 = @BT0800@/@BT0900@ in @DIAGST@		
42B1	Media Error	Diagnostic Test 7
42B2	Controller Hardware Error	Diagnostic Test 7
42B3	Checksum Does Not Match	Diagnostic Test 7
42B4	Drive Not Ready	Diagnostic Test 7
42B6	Program Error (Divide)	Diagnostic Test 7
42B8	Program Error (Data)	Diagnostic Test 7
42BA	Library Not Found	Diagnostic Test 7
42BB	File Not Found	Diagnostic Test 7
42BC	FDR1 Not Found	Diagnostic Test 7
42BE	Extents Greater Than 3	Diagnostic Test 7
Self-Test Diag. Test 8 = @MT0200@ in @DIAGST@		
42C1	Media Error	Diagnostic Test 8
42C2	Controller Hardware Error	Diagnostic Test 8
42C3	Checksum Does Not Match	Diagnostic Test 8
42C4	Drive Not Ready	Diagnostic Test 8
42C6	Program Error (Divide)	Diagnostic Test 8
42C8	Program Error (Data)	Diagnostic Test 8
42CA	Library Not Found	Diagnostic Test 8
42CB	File Not Found	Diagnostic Test 8
42CC	FDR1 Not Found	Diagnostic Test 8
42CE	Extents Greater Than 3	Diagnostic Test 8
42E0	SIO Time Out	
42E1	SIO Overrun	
42E2	SIO Data RAM Parity Error	
42E3	SIO Serial Parity Error	
42E4	(U)ISIO Time Out	
42E5	(U)ISIO Memory Parity	
42E6	(U)ISIO Data RAM Parity Error	
42E7	(U)ISIO Power Up Failed	
42E8	(U)ISIO Data Link Time Out	

►NEXT

6.4 TROUBLESHOOTING

6.4 Error Codes and Descriptions

6.4.3 BP2 Class Diagnostic Monitor Error Codes And Description (Sheet 8 of 17)

BP2 Class Diagnostic Monitor Error Code Analysis

<i>Error Code</i>	<i>Test/Error Description</i>	<i>Comments</i>
Self-Test Diag. Test 8 = @MT0200@ in @DIAGST@ (Con.t)		
42E9	(U)ISIO FIFO Parity	
42EA	Workstation Powered Off	
42EB	Workstation Coaxial Parity Error	
42EC	Workstation Memory Parity Error	
42ED	Workstation Has No Code	
42EE	Workstation Status Invalid	
42F2	CPU Failure	
42F3	Invalid Hardware Configuration	
42F4	Floppy Status Error	
42F5	No Terminal ID Byte Found	
43 Self-Test Diagnostic Test 1.1 = @ST0500@ in @DIAGST@		
4351	Media Error	Diagnostic Test 1.1 (SIO)
4352	Controller Hardware Error	Diagnostic Test 1.1 (SIO)
4353	Checksum Does Not Match	Diagnostic Test 1.1 (SIO)
4354	Drive Not Ready	Diagnostic Test 1.1 (SIO)
4356	Program Error (Divide)	Diagnostic Test 1.1 (SIO)
4358	Program Error (Data)	Diagnostic Test 1.1 (SIO)
435A	Library Not Found	Diagnostic Test 1.1 (SIO)
435B	File Not Found	Diagnostic Test 1.1 (SIO)
435C	FDR1 Not Found	Diagnostic Test 1.1 (SIO)
435E	Extents Greater Than 3	Diagnostic Test 1.1 (SIO)

►NEXT

6.4 TROUBLESHOOTING

6.4 Error Codes and Descriptions

6.4.3 BP2 Class Diagnostic Monitor Error Codes And Description (Sheet 9 of 17)

BP2 Class Diagnostic Monitor Error Code Analysis

<i>Error Code</i>	<i>Test/Error Description</i>	<i>Comments</i>
Self-Test Diag. Test 1.2 = @ST0800@ in @DIAGST@		
4361	Media Error	Diagnostic Test 1.2 (ISIO)
4362	Controller Hardware Error	Diagnostic Test 1.2 (ISIO)
4363	Checksum Does Not Match	Diagnostic Test 1.2 (ISIO)
4364	Drive Not Ready	Diagnostic Test 1.2 (ISIO)
4366	Program Error (Divide)	Diagnostic Test 1.2 (ISIO)
4368	Program Error (Data)	Diagnostic Test 1.2 (ISIO)
436A	Library Not Found	Diagnostic Test 1.2 (ISIO)
436B	File Not Found	Diagnostic Test 1.2 (ISIO)
436C	FDR1 Not Found	Diagnostic Test 1.2 (ISIO)
436E	Extents Greater Than 3	Diagnostic Test 1.2 (ISIO)
Self-Test Overlay 4 = @CM0800@/@CM0200@ in @DIAGST@		
4381	Media Error	Overlay 4
4382	Controller Hardware Error	Overlay 4
4383	Checksum Does Not Match	Overlay 4
4384	Drive Not Ready	Overlay 4
4386	Program Error (Divide)	Overlay 4
4388	Program Error (Data)	Overlay 4
438A	Library Not Found	Overlay 4
438B	File Not Found	Overlay 4
438C	FDR1 Not Found	Overlay 4
438E	Extents Greater Than 3	Overlay 4

➡ NEXT

6.4 TROUBLESHOOTING

6.4 Error Codes and Descriptions

6.4.3 BP2 Class Diagnostic Monitor Error Codes And Description (Sheet 10 of 17)

BP2 Class Diagnostic Monitor Error Code Analysis

<i>Error Code</i>	<i>Test/Error Description</i>	<i>Comments</i>
Self-Test Overlay 5 = @CMOB00@/@CM0300@ in @DIAGST@		
4391	Media Error	Overlay 5
4392	Controller Hardware Error	Overlay 5
4393	Checksum Does Not Match	Overlay 5
4394	Drive Not Ready	Overlay 5
4396	Program Error (Divide)	Overlay 5
4398	Program Error (Data)	Overlay 5
439A	Library Not Found	Overlay 5
439B	File Not Found	Overlay 5
439C	FDR1 Not Found	Overlay 5
439E	Extents Greater Than 3	Overlay 5
Self-Test Overlay 6 = @MM0500@/@MM0100@ in @DIAGST@		
43A1	Media Error	Overlay 6
43A2	Controller Hardware Error	Overlay 6
43A3	Checksum Does Not Match	Overlay 6
43A4	Drive Not Ready	Overlay 6
43A6	Program Error (Divide)	Overlay 6
43A8	Program Error (Data)	Overlay 6
43AA	Library Not Found	Overlay 6
43AB	File Not Found	Overlay 6
43AC	FDR1 Not Found	Overlay 6
43AE	Extents Greater Than 3	Overlay 6

►NEXT

6.4 Error Codes and Descriptions

TROUBLESHOOTING

6.4.3 BP2 Class Diagnostic Monitor Error Codes And Description (Sheet 11 of 17)

BP2 Class Diagnostic Monitor Error Code Analysis

<i>Error Code</i>	<i>Test/Error Description</i>	<i>Comments</i>
44	IPL System Loader (@MCIPL@ in @SYSTEM@)	
440F	Incompatible Version of Self-Test Code	
4410	Unlabeled Volume (VOL1 Missing)	Volume Label
4411	Media Error	Volume Label
4412	Controller Hardware Error	Volume Label
4414	Drive Not Ready	Volume Label
4416	Program Error (Divide)	Volume Label
4418	Program Error (Data)	Bit Map
4419	Media Error	Bit Map
441A	Controller Hardware Error	Bit Map
441C	Drive Not Ready	Bit Map
441E	Program Error (Divide)	Bit Map
4420	Program Error (Data)	VTOC
4421	Media Error	VTOC
4422	Controller Hardware Error	VTOC
4424	Drive Not Ready	VTOC
4426	Program Error (Divide)	VTOC
4428	Program Error (Data)	VTOC
442A	FDX1 ID Does Not Match	VTOC
442B	FDX2 ID Does Not Match	VTOC
442C	FDR1 ID Does Not Match	Workstation File
4431	Media Error	Workstation File
4432	Controller Hardware Error	Workstation File
4433	Checksum Does Not Match	Workstation File
4434	Drive Not Ready	Workstation File
4436	Program Error (Divide)	Workstation File
4438	Program Error (Data)	Workstation File
443A	Library Not Found	Workstation File
443B	File Not Found	Workstation File
443C	FDR1 Not Found	Workstation File
443E	Extents Greater Than 3	

►NEXT

6.4 Error Codes and Descriptions

6.4.3 BP2 Class Diagnostic Monitor Error Codes And Description (Sheet 12 of 17)

BP2 Class Diagnostic Monitor Error Code Analysis

<i>Error Code</i>	<i>Test/Error Description</i>	<i>Comments</i>
System File = @MCCP5@/@MCCP7@ in @SYSTEM@		
4461	Media Error	CP Microcode File
4462	Controller Hardware Error	CP Microcode File
4463	Checksum Does Not Match	CP Microcode File
4464	Drive Not Ready	CP Microcode File
4466	Program Error (Divide)	CP Microcode File
4468	Program Error (Data)	CP Microcode File
446A	Library Not Found	CP Microcode File
446B	File Not Found	CP Microcode File
446C	FDR1 Not Found	CP Microcode File
446E	Extents Greater Than 3	CP Microcode File
System File = @MCBP2@ in @SYSTEM@		
44C1	Media Error	@MCBP2@ File
44C2	Controller Hardware Error	@MCBP2@ File
44C3	Checksum Does Not Match	@MCBP2@ File
44C4	Drive Not Ready	@MCBP2@ File
44C6	Program Error (Divide)	@MCBP2@ File
44C8	Program Error (Data)	@MCBP2@ File
44CA	Library Not Found	@MCBP2@ File
44CB	File Not Found	@MCBP2@ File
44CC	FDR1 Not Found	@MCBP2@ File
44CE	Extents Greater Than 3	@MCBP2@ File

►NEXT

6.4 TROUBLESHOOTING

6.4 Error Codes and Descriptions

6.4.3 BP2 Class Diagnostic Monitor Error Codes And Description (Sheet 13 of 17)

BP2 Class Diagnostic Monitor Error Code Analysis

<i>Error Code</i>	<i>Test/Error Description</i>	<i>Comments</i>
System File = @MCBP2@ in @SYSTEM@ (Cont.)		
44E0	SIO Time Out	
44E1	SIO Overrun	
44E2	SIO Data RAM Parity Error	
44E3	SIO Serial Parity Error	
44E4	(U)ISIO Time Out	
44E5	(U)ISIO Memory Parity	
44E6	(U)ISIO Data RAM Parity Error	
44E7	(U)ISIO Power Up Failed	
44E8	(U)ISIO Data Link Time Out	
44E9	(U)ISIO FIFO Parity	
44EA	Workstation Powered Off	
44EB	Workstation Coaxial Parity Error	
44EC	Workstation Memory Parity Error	
44ED	Workstation Has No Code	
44EE	Workstation Status Invalid	
44F0	DMA Time Out	
44F1	DMA Failure	
44F2	CPU Failure	
44F3	Invalid Hardware Configuration	
44F4	Floppy Status Error	
45 Diagnostic Monitor = @MONITOR@ in @DIAGMN@		
4505	Monitor Message Buffer Overflow	
450F	Incompatible Version Of Diagnostic Code	
4510	Unlabeled Volume (VOL1 Missing)	Volume Label
4511	Media Error	Volume Label
4512	Controller Hardware Error	Volume Label
4514	Drive Not Ready	Volume Label
4516	Program Error (Divide)	Volume Label
4518	Program Error (Data)	Bit Map
4519	Media Error	

►NEXT

6.4 Error Codes and Descriptions

TRUBLESHOOTING

6.4.3 BP2 Class Diagnostic Monitor Error Codes And Description (Sheet 14 of 17)

BP2 Class Diagnostic Monitor Error Code Analysis

<i>Error Code</i>	<i>Test/Error Description</i>	<i>Comments</i>
45	Diagnostic Monitor = @MONITOR@ in @DIAGMN@ (Cont.)	
451A	Controller Hardware Error	Bit Map
451C	Drive Not Ready	Bit Map
451E	Program Error (Divide)	Bit Map
4520	Program Error (Data)	Bit Map
4521	Media Error	VTOC
4522	Controller Hardware Error	VTOC
4524	Drive Not Ready	VTOC
4526	Program Error (Divide)	VTOC
4528	Program Error (Data)	VTOC
452A	FDX1 ID Does Not Match	VTOC
452B	FDX2 ID Does Not Match	VTOC
452C	FDR1 ID Does Not Match	VTOC
Test Table File = @MONTBL@ in @DIAGMN@		
4531	Media Error	Test Table File
4532	Controller Hardware Error	Test Table File
4533	Checksum Does Not Match	Test Table File
4534	Drive Not Ready	Test Table File
4536	Program Error (Divide)	Test Table File
4538	Program Error (Data)	Test Table File
453A	Library Not Found	Test Table File
453B	File Not Found	Test Table File
453C	FDR1 Not Found	Test Table File
453E	Extents Greater Than 3	Test Table File

➡NEXT

6.4 TROUBLESHOOTING

6.4 Error Codes and Descriptions

6.4.3 BP2 Class Diagnostic Monitor Error Codes And Description (Sheet 15 of 17)

BP2 Class Diagnostic Monitor Error Code Analysis

<i>Error Code</i>	<i>Test/Error Description</i>	<i>Comments</i>
Workstation File = @MONWSO@ in @DIAGMN@		
4541	Media Error	Workstation File
4542	Controller Hardware Error	Workstation File
4543	Checksum Does Not Match	Workstation File
4544	Drive Not Ready	Workstation File
4546	Program Error (Divide)	Workstation File
4548	Program Error (Data)	Workstation File
454A	Library Not Found	Workstation File
454B	File Not Found	Workstation File
454C	FDR1 Not Found	Workstation File
454E	Extents Greater Than 3	Workstation File
ISIO File = @MONISIO@ in @DIAGMN@		
4551	Media Error	ISIO File
4552	Controller Hardware Error	ISIO File
4553	Checksum Does Not Match	ISIO File
4554	Drive Not Ready	ISIO File
4556	Program Error (Divide)	ISIO File
4558	Program Error (Data)	ISIO File
455A	Library Not Found	ISIO File
455B	File Not Found	ISIO File
455C	FDR1 Not Found	ISIO File
455E	Extents Greater Than 3	ISIO File
45E0	SIO Time Out	
45E1	SIO Overrun	
45E2	SIO Data RAM Parity Error	
45E3	SIO Serial Parity Error	

◆NEXT

6.4 TROUBLESHOOTING

6.4 Error Codes and Descriptions

6.4.3 BP2 Class Diagnostic Monitor Error Codes And Description (Sheet 16 of 17)

BP2 Class Diagnostic Monitor Error Code Analysis

<i>Error Code</i>	<i>Test/Error Description</i>	<i>Comments</i>
ISIO File = @MONISIO@ in @DIAGMN@		
45E4	{U}ISIO Time Out	
45E5	{U}ISIO Memory Parity	
45E6	{U}ISIO Data RAM Parity Error	
45E7	{U}ISIO Power Up Failed	
45E8	{U}ISIO Data Link Time Out	
45E9	{U}ISIO FIFO Parity	
45EA	Workstation Powered Off	
45EB	Workstation Coaxial Parity Error	
45EC	Workstation Memory Parity Error	
45ED	Workstation Has No Code	
45EE	Workstation Status Invalid	
45F0	DMA Time Out	
45F1	DMA Failure	
45F2	CPU Failure	
45F3	Invalid Hardware Configuration	
45F4	Floppy Status Error	
45F5	No Terminal ID Byte Found	
45FA	Lost Data Set Ready	
45FB	Transmit Data Error	
45FC	Receive Data Error	
46 Diagnostic Monitor Test Files		
46X1	Media Error	Test File X
46X2	Controller Hardware Error	Test File X
46X3	Checksum Does Not Match	Test File X
46X4	Drive Not Ready	Test File X
46X6	Program Error (Divide)	Test File X
46X8	Program Error (Data)	Test File X
46XA	Library Not Found	Test File X
46XB	File Not Found	Test File X
46XC	FDR1 Not Found	Test File X
46XE	Extents Greater Than 3	Test File X

◆NEXT

6.4 Error Codes and Descriptions

TROUBLESHOOTING

6.4.3 BP2 Class Diagnostic Monitor Error Codes And Description (Sheet 17 of 17)

BP2 Class Diagnostic Monitor Error Code Analysis

<i>Error Code</i>	<i>Test/Error Description</i>	<i>Comments</i>
47	Diagnostic Monitor Test Files	
47X1	Media Error	Test File X + 15
47X2	Controller Hardware Error	Test File X + 15
47X3	Checksum Does Not Match	Test File X + 15
47X4	Drive Not Ready	Test File X + 15
47X6	Program Error (Divide)	Test File X + 15
47X8	Program Error (Data)	Test File X + 15
47XA	Library Not Found	Test File X + 15
47XB	File Not Found	Test File X + 15
47XC	FDR1 Not Found	Test File X + 15
47XE	Extents Greater Than 3	Test File X + 15
48	Diagnostic Monitor Overlay Files	
48X1	Media Error	Test File X
48X2	Controller Hardware Error	Test File X
48X3	Checksum Does Not Match	Test File X
48X4	Drive Not Ready	Test File X
48X6	Program Error (Divide)	Test File X
48X8	Program Error (Data)	Test File X
48XA	Library Not Found	Test File X
48XB	File Not Found	Test File X
48XC	FDR1 Not Found	Test File X
48XE	Extents Greater Than 3	Test File X
49	Diagnostic Monitor Overlay Files	
49X1	Media Error	Test File X + 15
49X2	Controller Hardware Error	Test File X + 15
49X3	Checksum Does Not Match	Test File X + 15
49X4	Drive Not Ready	Test File X + 15
49X6	Program Error (Divide)	Test File X + 15
49X8	Program Error (Data)	Test File X + 15
49XA	Library Not Found	Test File X + 15
49XB	File Not Found	Test File X + 15
49XC	FDR1 Not Found	Test File X + 15
49XE	Extents Greater Than 3	Test File X + 15

● END

6.4 Error Codes and Descriptions

6.4 Error Codes and Descriptions

6.4.4 Self-Test Diagnostic Execution Error Codes And Description (Sheet 1 of 20)

Self-Test Diagnostic Error Code Analysis

Error Code *Test/Error Description*

**4B CP Control Memory And Communications Self-Test
[@CT0100@ from @DIAGST@ Execution]**

4B80 Central Processor does not respond to HALT command from Bus Processor or CP, MIC cannot be loaded to zero (0) from BP

4B81 Data miscompare on low halfword of Control Memory

4B82 Central Processor External Bus error

4B83 Unable to Read/Write Control Memory

4B84 Data miscompare on middle halfword of Control Memory

4B85 Data miscompare on high halfword of Control Memory

4B86 Central Processor MIC data miscompare

4B87 Data bit and possible addressing error when accessing low halfword of Control Memory

4B88 Data bit and possible addressing error when accessing middle halfword of Control Memory

4B89 Data bit and possible addressing error when accessing high halfword of Control Memory

4B8A Error in address line, Control Memory low halfword overwritten

4B8B Error in address line, Control Memory middle halfword overwritten

4B8C Error in address line, Control Memory high halfword overwritten

►NEXT

6.4

TROUBLESHOOTING

Error Codes and Descriptions

6.4.4 Self-Test Diagnostic Execution Error Codes And Description (Sheet 2 of 20)

Self-Test Diagnostic Error Code Analysis

Error Code Test/Error Description

4B CP Control Memory And Communications Self-Test (Cont.)

4B8D Data miscompare in Read/Write sequence for Control Memory low halfword

4B8E Data miscompare in Read/Write sequence for Control Memory middle halfword

4B8F Data miscompare in Read/Write sequence for Control Memory high halfword

4B90 Possible memory pattern sensitivity error (noise) on Control Memory low halfword

4B91 Possible memory pattern sensitivity error (noise) on Control Memory middle halfword

4B92 Possible memory pattern sensitivity error (noise) on Control Memory high halfword

4B93 Central Processor hardware status register error: Bit 0 not set after issuing halt

4B94 Central Processor hardware status register error: Bit 1 not reset when comparator disabled

4B95 Central Processor hardware status register error: Bit 1 not set when comparator enabled

4B96 Central Processor hardware status register error: Bit 0 not set after execution of NOP instruction which should indicate halt

►NEXT

6.4 TROUBLESHOOTING

6.4 Error Codes and Descriptions

6.4.4 Self-Test Diagnostic Execution Error Codes And Description (Sheet 3 of 20)

Self-Test Diagnostic Error Code Analysis

Error Code *Test/Error Description*

4B CP Control Memory And Communications Self-Test (Cont.)

4B97 Central Processor Halted interrupt not detected after execution of NOP instruction

4B98 CP hardware status register error: Central Processor CIO 7 status bit (bit 3) not set after execution of a NOP instruction

4B99 CP Halted interrupt not detected when a CIO 7 instruction executed

4B9A CP hardware status register error: Central Processor CIO 7 status bit (bit 3) not reset after execution of a NOP instruction

4B9B Sync interrupt not detected when comparator was enabled and MIC and comparator address should have been the same

4B9C Forced parity error not detected

4B9D Control Memory parity check error, Possible open on data line for low halfword of control memory

4B9E Control Memory parity check error, Possible open on data line for middle halfword of control memory

4B9F Control Memory parity check error, Possible open on data line for high halfword of control memory

4BA0 Central Processor MIC value incorrect after step

4BA1 Central Processor IO3 status bit not cleared

4BA2 BP IO3 status bit not reset

►NEXT

6.4 Error Codes and Descriptions

6.4 Error Codes and Descriptions

6.4.4 Self-Test Diagnostic Execution Error Codes And Description (Sheet 4 of 20)

Self-Test Diagnostic Error Code Analysis

<i>Error Code</i>	<i>Test/Error Description</i>
4B	CP Control Memory And Communications Self-Test (Cont.)
4BA3	Central Processor IO4 status bit not cleared
4BA4	BP IO4B status bit not set after clear IO4B executed by CP
4BA5	BP IO4B status bit not cleared by Central Processor
4BA6	BP IO3 status bit not set
4BA7	BP IO4B status bit not set
4BA8	IO4B status bit not set by BP command
4BA9	IO3 status bit not set by BP command
4BAA	IO3 interrupt not detected when IO3 cleared
4BAB	IO4B interrupt not detected when IO4B cleared
4BAC	Central Processor not halted at CIO 7 instruction
4BAD	Sync interrupt not received with comparator disables
4BAE	MIC incorrect after CIO 7 executed
4BAF	Central Processor not halted at Sync address with Sync halt enable
4BB0	Sync interrupt not taken with sync halt enable
4BB1	Halt interrupt not taken with sync halt enable
4BB2	Unexpected C-Bus latch contents after ORI instruction
4BB3	Multiple Halt interrupts occurred
4BB4	Multiple IO4B interrupts occurred
4BB5	Multiple IO3 interrupts occurred
4BB6	Multiple Sync interrupts occurred
4BB7	Time-out on Free-Running Test, Halt interrupt should have occurred

►NEXT

6.4 TROUBLESHOOTING

6.4 Error Codes and Descriptions

6.4.4 Self-Test Diagnostic Execution Error Codes And Description (Sheet 5 of 20)

Self-Test Diagnostic Error Code Analysis

Error Code Test/Error Description

**4C Central Processor Operational Self-Test
(@CT0200@ from @DIAGST@ Execution)**

4C80 Time-out error; Central Processor did not halt when expected or halt interrupt was not detected, Probable CP or Main Memory failure

4C90 CP detected error in Central Processor or Main Memory

4CFC Multiple Halt interrupts occurred

4CFD Multiple IO3 interrupts occurred

4CFE Multiple IO4B interrupts occurred

4CFF Multiple Sync interrupts occurred

**4D Central Processor Integrity Self-Test
(@CT0300@ from @DIAGST@ Execution)**

4D80 Time-out error; Central Processor did not halt when expected or halt interrupt was not detected, Probable CP or Main Memory failure

4D90 Central Processor detected error in Central Processor or Main Memory

4DFC Multiple Halt interrupts occurred

4DFD Multiple IO3 interrupts occurred

4DFE Multiple IO4B interrupts occurred

4DFF Multiple Sync interrupts occurred

►NEXT

6.4 Error Codes and Descriptions

TROUBLESHOOTING

6.4.4 Self-Test Diagnostic Execution Error Codes And Description (Sheet 6 of 20)

Self-Test Diagnostic Error Code Analysis

Error Code *Test/Error Description*

**4Ex CP/Cache/Main Memory (Integrity) Self-Test
(@MT0100@ from @DIAGST@ Execution)**

4E80 Time-out error; Central Processor did not halt when expected or halt interrupt was not detected, Probable CP or Main Memory failure

4E90 Central Processor detected error in Central Processor or Main Memory PCA

4EFC Multiple Halt interrupts occurred

4EFD Multiple IO3 interrupts occurred

4EFE Multiple IO4B interrupts occurred

4EFF Multiple Sync interrupts occurred

**4EA Dual Processor (BP and CP) to Main Memory/Cache Self-Test
(@MM0200@ from @DIAGST@ Execution)**

4EA0 Central Processor detected error in CP or Main Memory PCA

4EA1 BP detected incomplete DMA during Main Memory WRITE operation

4EA3 BP detected incomplete DMA during Main Memory READ operation

4EA4 BP detected data miscompare in READ/WRITE sequence for Main Memory

4EA5 BP detected data miscompare in READ/WRITE sequence for Main Memory

4EA6 BP detected data miscompare in READ/WRITE sequence for Main Memory

►NEXT

6

TROUBLESHOOTING

4 Error Codes and Descriptions

6.4.4 Self-Test Diagnostic Execution Error Codes And Description (Sheet 7 of 20)

Self-Test Diagnostic Error Code Analysis

<i>Error Code</i>	<i>Test/Error Description</i>
4EA	Dual Processor (BP and CP) to Main Memory/Cache Self-Test (Cont.)
4EA7	BP detected data miscompare in READ/WRITE sequence for Main Memory
4EAA	Time-out error; Central Processor did not HALT when expected or HALT interrupt was not detected, (Probable CP or MM failure)
4EAC	Central Processor HALTed at an undefined location
4EAD	Unrecoverable (Fatal) error occurred
4EAE	Central Processor HALTed at an incorrect location
4EAF	Multiple interrupts occurred
4F	Bus Processor/Main Memory DMA Self-Test (@BT0900@ from @DIAGST@ Execution)
4F01	Continuous Main Memory error correction count interrupt
4F02	Continuous Bus Processor/Main Memory DMA interrupt
4F03	Continuous Central Processor sync interrupt
4F11	DRAM MAR data compare failure
4F21	DRAM MAR changed after diagnostic ripple with ripple controls equal to 'zero'
4F22	DRAM MAR incorrect value after diagnostic ripple with ripple controls equal to 'one'
4F23	DRAM MAR incorrect value after diagnostic ripple with ripple controls equal to 'two'

►NEXT

6.4 Error Codes and Descriptions

TROUBLESHOOTING

6.4.4 Self-Test Diagnostic Execution Error Codes And Description (Sheet 8 of 20)

Self-Test Diagnostic Error Code Analysis

<i>Error Code</i>	<i>Test/Error Description</i>
4F	Bus Processor/Main Memory DMA Self-Test (Cont.)
4F31	Main Memory MAR low data compare failure
4F32	Main Memory MAR high data compare failure
4F41	Main Memory MAR low incorrect value after diagnostic ripple
4F42	Main Memory MAR high incorrect value after diagnostic ripple
4F81	No DMA completion interrupt on transfer from DRAM to Main Memory address 'zero'
4F82	No DMA completion interrupt on transfer from Main Memory address 'zero' to DRAM address displayed
4F83	No data transferred on DMA from Main Memory address 'zero'
4F84	DRAM addressing failure: Actual address of transfer displayed not equal to expected address
4F91	No DMA completion interrupt on transfer from DRAM to Main Memory address 'zero'
4F92	No DMA completion interrupt on transfer from Main Memory to DRAM address 'zero'
4F93	Data bus failure: Received data not equal to expected data
4F94	Bus Processor DMA error status bits set on transfer from DRAM to Main Memory address 'zero', (Bus Processor status displayed)
4F95	Bus Processor DMA error status bits set on transfer from Main Memory to DRAM address 'zero', (Bus Processor status displayed)
4FA1	No DMA completion interrupt on transfer from DRAM to Main Memory address 'zero'

◆NEXT

6.4

TROUBLESHOOTING

Error Codes and Descriptions

6.4.4 Self-Test Diagnostic Execution Error Codes And Description (Sheet 9 of 20)

Self-Test Diagnostic Error Code Analysis

<i>Error Code</i>	<i>Test / Error Description</i>
4F	Bus Processor/Main Memory DMA Self-Test (Cont.)
4FA2	Bus Processor DMA error status bits set on transfer from DRAM to Main Memory address 'zero', (Bus Processor status displayed)
4FA3	No DMA completion interrupt on transfer from Main Memory to DRAM address 'zero'
4FA4	BP DMA error status bits set on transfer from DRAM to Main Memory address 'zero'
4FA5	Data received from Main Memory did not match expected data
4FA6	No DMA completion interrupt on transfer from DRAM address 'zero' to Main Memory address displayed
4FA7	BP DMA error status bits set on transfer from DRAM address 'zero' to Main Memory address displayed
4FA8	Main Memory Invalid Memory Address (IMA) status bit set on access to valid Main Memory location
4FA9	DRAM data altered on Main Memory IMA fault
4FAA	No DMA completion interrupt on transfer from DRAM address 'zero' to Main Memory scan address displayed
4FAB	Bus Processor DMA error status bits set on transfer from DRAM address 'zero' to Main Memory scan address displayed
4FAC	Main Memory addressing failure: Data received from Main Memory scan location did not match expected data
4FAD	Main Memory addressing failure: Data received from Main Memory test location did not match expected data
4FAE	DRAM data altered by DMA to Main Memory test location
4FAF	Access to Main Memory address greater than Lowest Word Address (LWA) set by Central Processor; sizing did not generate IMA fault

►NEXT

6.4 Error Codes and Descriptions

TROUBLESHOOTING

6.4.4 Self-Test Diagnostic Execution Error Codes And Description (Sheet 10 of 20)

Self-Test Diagnostic Error Code Analysis

<i>Error Code</i>	<i>Test/Error Description</i>
4F	Bus Processor/Main Memory DMA Self-Test (Cont.)
4FD8	No DMA completion interrupt on multiword transfer from DRAM to Main Memory with MAR ripple equal to one
4FD9	DMA register count fault: Received Value did not equal Expected Value
4FE1	Unexpected interrupt from Main Memory ECC logging counter after initial programming
4FE2	No DMA completion interrupt on 2K halfword transfer from DRAM to Main Memory
4FE3	Bus Processor DMA error status bits set on 2K halfword transfer from DRAM to Main Memory
4FE4	Unexpected interrupt from ECC logging counter on 2K halfword transfer from DRAM to Main Memory
4FE5	No DMA completion interrupt on 2K halfword transfer from DRAM to Main Memory while operating in the non-ECC mode
4FE6	Bus Processor DMA error status bits set on 2K halfword transfer from DRAM to Main Memory while operating in the non-ECC mode
4FE7	Unexpected interrupt from ECC logging counter on 2K halfword transfer from DRAM to Main Memory while operating in the non-ECC mode
4FE8	No DMA completion interrupt on 2K halfword transfer to DRAM from MM
4FE9	Bus Processor DMA error status bits set on 2K halfword transfer to DRAM from Main Memory

►NEXT

6.4 Error Codes and Descriptions

6.4.4 Self-Test Diagnostic Execution Error Codes And Description (Sheet 11 of 20)

Self-Test Diagnostic Error Code Analysis

Error Code Test/Error Description

4F Bus Processor/Main Memory DMA Self-Test (Cont.)

4FEA	Single-bit Main Memory error not corrected on 2K DMA transfer
4FEB	Incorrect number or error corrections logged on 2K DMA transfer
4FEC	No DMA completion interrupt on 2K halfword transfer from DRAM to Main Memory while operating in the non-ECC mode
4FED	Bus Processor DMA error status bits set on 2K halfword transfer from DRAM to Main Memory while operating in the non-ECC mode
4FEE	Unexpected interrupt from ECC logging counter on 2K halfword transfer from DRAM to Main Memory while operating in the non-ECC mode
4FEF	No DMA completion interrupt on attempted 2K halfword transfer to DRAM from Main Memory with uncorrectable data
4FF0	BP Main Memory ECC status bit not set after Main Memory read of uncorrectable data
4FF1	Correctable ECC logging interrupt did not occur with limit count equal to transfer length and single-bit error correction attempted
4FF2	DMA operation did not abort on Main Memory uncorrectable ECC error
4FF3	No DMA completion interrupt on attempted transfer from Main Memory address 100000 HEX to DRAM
4FF4	Bus Processor Main Memory Invalid Memory Address (IMA) status bit not set after attempted access to Main Memory location 100000 HEX

►NEXT

6.4 Error Codes and Descriptions

6.4 Error Codes and Descriptions

6.4.4 Self-Test Diagnostic Execution Error Codes And Description (Sheet 12 of 20)

Self-Test Diagnostic Error Code Analysis

Error Code Test/Error Description

4F Bus Processor/Main Memory DMA Self-Test (Cont.)

4FF5	DMA operation did not abort on Main Memory IMA error
4FF6	No DMA completion interrupt on attempted 2K halfword DRAM to Main Memory transfer with bad DRAM parity
4FF7	Bus Processor Main Memory DSB status bit not set after attempted read of DRAM with bad parity
4FF8	DMA operation did not abort on DRAM parity error
4FF9	No DMA completion interrupt on DRAM to Main Memory transfer after correcting DRAM parity
4FFA	Bus Processor DMA error status bit set on DRAM to Main Memory transfer after correcting DRAM parity
4FFB	Unexpected interrupt from ECC logging counter on DRAM to Main Memory transfer after correcting DRAM parity
4FFC	No DMA completion interrupt on two-halfword transfer to DRAM from Main Memory to start PIT clock
4FFD	No DMA completion interrupt on two-halfword transfer from DRAM to Main Memory rewrite "bad" data
4FFE	Bus Processor DMA error status bits set on two-halfword transfer from DRAM to Main Memory

►NEXT

6.4 TROUBLESHOOTING

6.4 Error Codes and Descriptions

6.4.4 Self-Test Diagnostic Execution Error Codes And Description (Sheet 13 of 20)

Self-Test Diagnostic Error Code Analysis

<i>Error Code</i>	<i>Test/Error Description</i>
70-76	Universal ISIO DAC Self-Test (@ST0800@ from @DIAGST@ Execution)
7010	UISIO (928W) PCA identification not found on system
7011	Device adapter ready bit failed to be set, software status register indicates that the internal power-up failed; (Software status register has not been tested at this time)
7012	Device adapter ready bit failed to be set
7013	Device adapter ready bit failed to be reset
7014	Device adapter request bit failed to be set
7016	Device adapter request interrupt failed to be detected
7017	Illegal interrupt detected (DA request interrupt expected)
7018	Device adapter request bit failed to be reset
701A	Device adapter request failed to be set
701C	Device adapter ready interrupt failed to be detected
701D	Illegal interrupt detected (DA ready interrupt was expected)
701E	Software status register failed walking ones pattern
7020	Local DMA Controller Buffer Full, Flip-Flop (F/F) failed to reset
7021	LDCBF, F/F failed to be set
7022	UISIO (or 928W) failed to internally detect a completion interrupt

►NEXT

6.4 TROUBLESHOOTING

6.4 Error Codes and Descriptions

6.4.4 Self-Test Diagnostic Execution Error Codes And Description (Sheet 14 of 20)

Self-Test Diagnostic Error Code Analysis

<i>Error Code</i>	<i>Test/Error Description</i>
70-76	Universal ISIO DAC Self-Test (Cont.)
7023	Local DMA Controller Byte Counter (LDCBC) F/F failed to be reset
7024	UISIO (or 928W) failed to internally detect LDCBC F/F being reset
7025	Static RAM Byte Counter (SRBC) F/F failed to be reset
7026	SRBC F/F failed to be set
7027	Device adapter completion interrupt failed to be detected
7028	Illegal interrupt detected
7029	UISIO (or 928W) failed to internally detect a completion interrupt
702A	SRBC F/F failed to be reset
702B	UISIO (or 928W) failed to detect SRBC F/F being reset
702C	Loading of LDCBC (with control register equal to SR/DR) failed to reset LDCBC F/F
702D	Loading of SRBC (with control register equal to 0) failed to prevent SRBC F/F from resetting
702E	Loading of SRBC (with control register equal to 0) failed to reset SRBC F/F
702F	UISIO (or 928W) failed to set up for DMA operations
703C	UISIO (or 928W) failed to select Static RAM (SR) Bank 1
7042	Dynamic RAM (DR) to SR Bank 1 (SRB-1) DMA: completion interrupt failed to be detected

►NEXT

6.4 Error Codes and Descriptions

TROUBLESHOOTING

6.4.4 Self-Test Diagnostic Execution Error Codes And Description (Sheet 15 of 20)

Self-Test Diagnostic Error Code Analysis

<i>Error Code</i>	<i>Test/Error Description</i>
70-76	Universal ISIO DAC Self-Test (Cont.)
7044	DR to SRB-1 DMA: ready interrupt failed to be detected
7046	DR to SRB-1 DMA: request interrupt failed to be detected
7048	DR to SRB-1 DMA: hardware status bits failed
704A	DR to SRB-1 DMA: software status bits failed
7052	Dynamic RAM to Z80 and SRB-1 to Main Memory concurrent DMAs: completion interrupt failed to be detected
7058	DR to Z80 and SRB-1 to Main Memory concurrent DMAs: hardware status bits failed
705A	DR to Z80 and SRB-1 to Main Memory concurrent DMAs: software status bits failed
705E	DR to Z80 and SRB-1 to Main Memory concurrent DMAs: interrupts failed (expected one Completion, two Readys, and two Requests)
706C	UISIO (or 928W) failed to select SR Bank 2 (SRB-2)
7072	Z80 to DR and Main Memory to SRB-2 concurrent DMAs: completion interrupt failed to be detected
7078	Z80 to DR and Main Memory to SRB-2 concurrent DMAs: hardware status bits failed
707A	Z80 to DR and Main Memory to SRB-2 concurrent DMAs: software status bits failed
707E	Z80 to DR and Main Memory to SRB-2 concurrent DMAs: interrupts failed (expected one Completion, two Readys, and two Requests)

►NEXT

6.4

TROUBLESHOOTING

Error Codes and Descriptions

6.4.4 Self-Test Diagnostic Execution Error Codes And Description (Sheet 16 of 20)

Self-Test Diagnostic Error Code Analysis

<i>Error Code</i>	<i>Test/Error Description</i>
70-76	Universal ISIO DAC Self-Test (Cont.)
7082	SR Bank 2 to DR DMA: completion interrupt failed to be detected
7084	SRB-2 to DR DMA: ready interrupt failed to be detected
7086	SRB-2 to DR DMA: request interrupt failed to be detected
7088	SRB-2 to DR DMA: hardware status bits failed
708A	SRB-2 to DR DMA: software status bits failed
7090	Data transfer failure
70B0	Failure to enable microcode loading step 1
70B2	Failure to enable microcode loading step 2
70B4	Failure to enable microcode loading step 3
70B6	Failure to enable microcode loading step 4
70FD	Unexpected trap
70FE	Unexpected SIO interrupt
70FF	Get control of workstation failure
7101	Address latch integrity error
71FE	Unexpected SIO interrupt (See Note)

NOTE

This error code is also given instead of error code '4500' when the Local/Remote Diagnostic/Remote Control switch is in the Remote Diagnostic position because the Diagnostic Monitor is not on the system disk.

◆NEXT

6.4 Error Codes and Descriptions

6.4 Error Codes and Descriptions

6.4.4 Self-Test Diagnostic Execution Error Codes And Description (Sheet 17 of 20)

Self-Test Diagnostic Error Code Analysis

<i>Error Code</i>	<i>Test/Error Description</i>
70-76	Universal ISIO DAC Self-Test (Cont.)
7201	Write byte completion interrupt failure
7202	Read byte completion interrupt failure
7203	Read and test data; (Also indicates 'Workstation Zero inoperable')
7204	SIO status error
7205	Static RAM MAR (SMAR) ripple failure
72FF	Get control of workstation failure
7301	Write 256 completion interrupt failure
7302	Read 256 completion interrupt failure
7303	Read and test data
7304	SIO status error
7305	SMAR ripple failure
73FF	Get control of workstation failure
7601	Give status completion interrupt failure
7602	Status unchanged
7603	Valid status
7604	Valid device type
76FF	Get control of workstation failure

◆NEXT

6.4 TROUBLESHOOTING

6.4 Error Codes and Descriptions

6.4.4 Self-Test Diagnostic Execution Error Codes And Description (Sheet 18 of 20)

Self-Test Diagnostic Error Code Analysis

<i>Error Code</i>	<i>Test/Error Description</i>
90	Serial Input/Output Device Adapter Self-Test (@ST0500@ from @DIAGST@ Execution)
9011	Workstation powered-off (or disconnected) status
9015	Coaxial parity failure, parity error, or not running status

NOTE

Diagnostic Error Codes 98xx, B0xx and D0xx are PROM-based diagnostics executed during power-up sequence.

98	Diskette Device Self-Test Diagnostic (PROM-Based)
9820	Diskette drive not ready; (Also indicates 'No floppy in IPL/Boot Device')
9821	Failure on initial Diskette recalibration
9822	Failure on Diskette seek to maximum track (track 77)
9823	Failure on Diskette seek to track 00

►NEXT

6.4 Error Codes and Descriptions

TROUBLESHOOTING

6.4.4 Self-Test Diagnostic Execution Error Codes And Description (Sheet 19 of 20)

Self-Test Diagnostic Error Code Analysis

<i>Error Code</i>	<i>Test/Error Description</i>
A4	Serial Input/Output Self-Test Diagnostic (@ST0100@ from @DIAGST@ Execution)
A400	SIO or WS-0 hung on Self-Test Diagnostic entry
A401	SIO or WS-0 identification not found
A402	SMAR data integrity failure
A4FD	Unexpected trap
A4FE	Unexpected SIO interrupt
A4FF	Get control of workstation failure
B0	External Disk Drive Device Adapter Self-Test (PROM-Based)
B000	Hung on entry to disk drive device adapter Self-Test Diagnostic
B004	Ready status bit failed to set
B012	Disk drive device adapter not found on the system
B014	Disk drive device adapter port specified does not exist
B016	Disk drive device adapter at an illegal address (0400 HEX, 0500 HEX, or 0600 HEX)
B022	Disk drive device adapter could not be properly reset
B032	Disk drive could not be selected
B034	Drive Fault could not be cleared
B042	Seek interrupt not detected after a restore (RTZ - Return to Track Zero) operation
B048	Seek interrupt not detected after a Seek to Track operation

►NEXT

6.4 Error Codes and Descriptions

6.4 Error Codes and Descriptions

6.4.4 Self-Test Diagnostic Execution Error Codes And Description (Sheet 20 of 20)

Self-Test Diagnostic Error Code Analysis

<i>Error Code</i>	<i>Test/Error Description</i>
B0	External Disk Drive Device Adapter Self-Test (PROM-Based) (Cont.)
B052	ECC error could not be corrected
B062	Operation complete interrupt not detected after a read operation
B068	Operation complete interrupt not detected after an ECC correction operation
B082	Drive status error after restore (RTZ) operation
B084	Drive status error after seek operation
B086	Drive status error after read operation
B092	Read sector operation failed (HCE - Header Check Error)
B094	Read sector operation failed
D0	Hardware Related Failure (PROM-Based)
DEAD	Program trap for attempted execution from nonexistent memory space (GRAM address branch leads to address in 80286 PROM)
XX	Miscellaneous Error Codes
xxFD	Unexpected trap
xxFE	Unexpected SIO interrupt
xxFF	Get control of Workstation Zero failure

◆ END

6.5 Troubleshooting Flowcharts

6.5.1 Power-Up Procedure (Sheet 1 of 6)

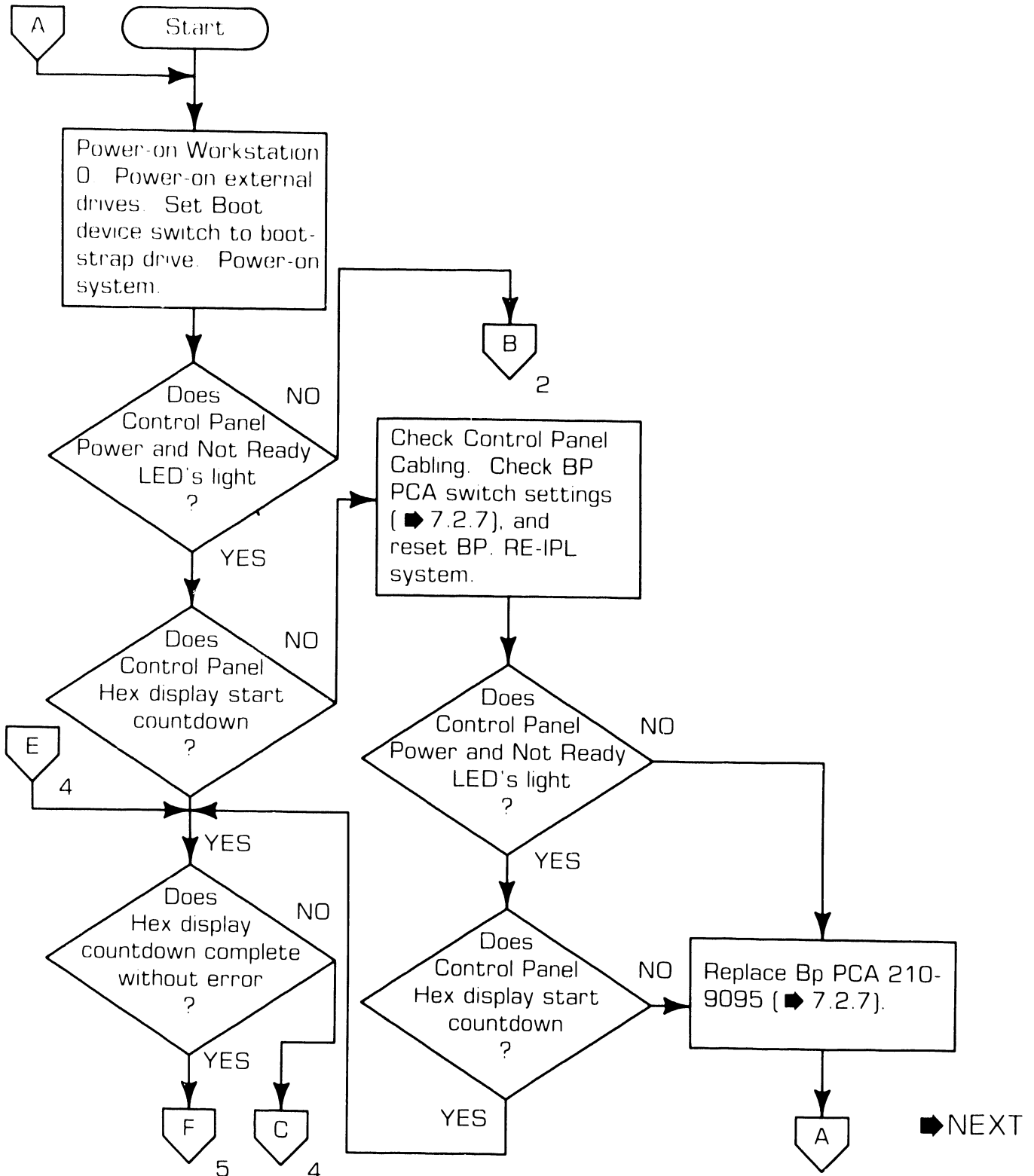

6.5 Troubleshooting Flowcharts

6.5.1 Power-Up Procedure (Sheet 2 of 6)

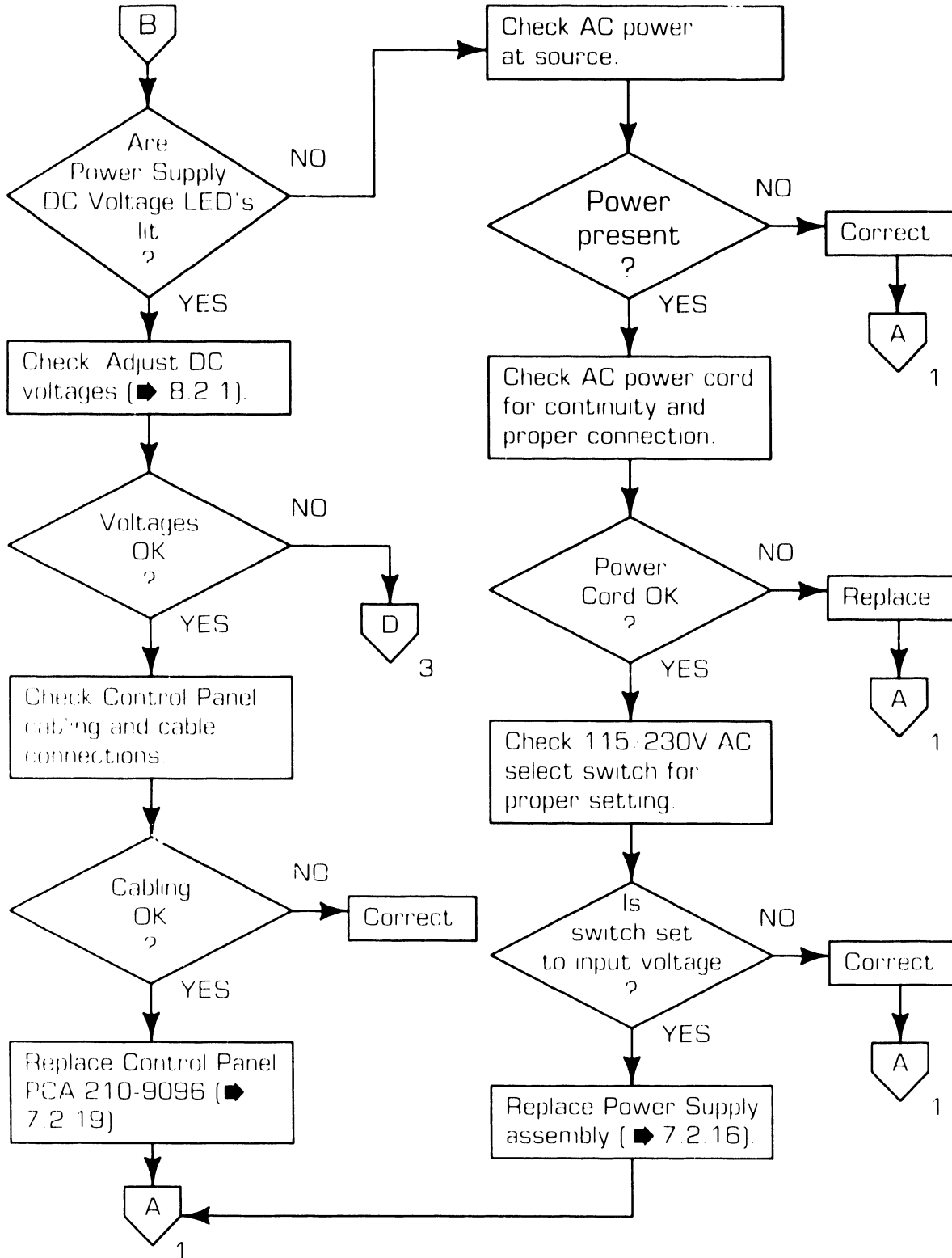

➡ NEXT

6.5 Troubleshooting Flowcharts

6.5.1 Power-Up Procedure (Sheet 3 of 6)

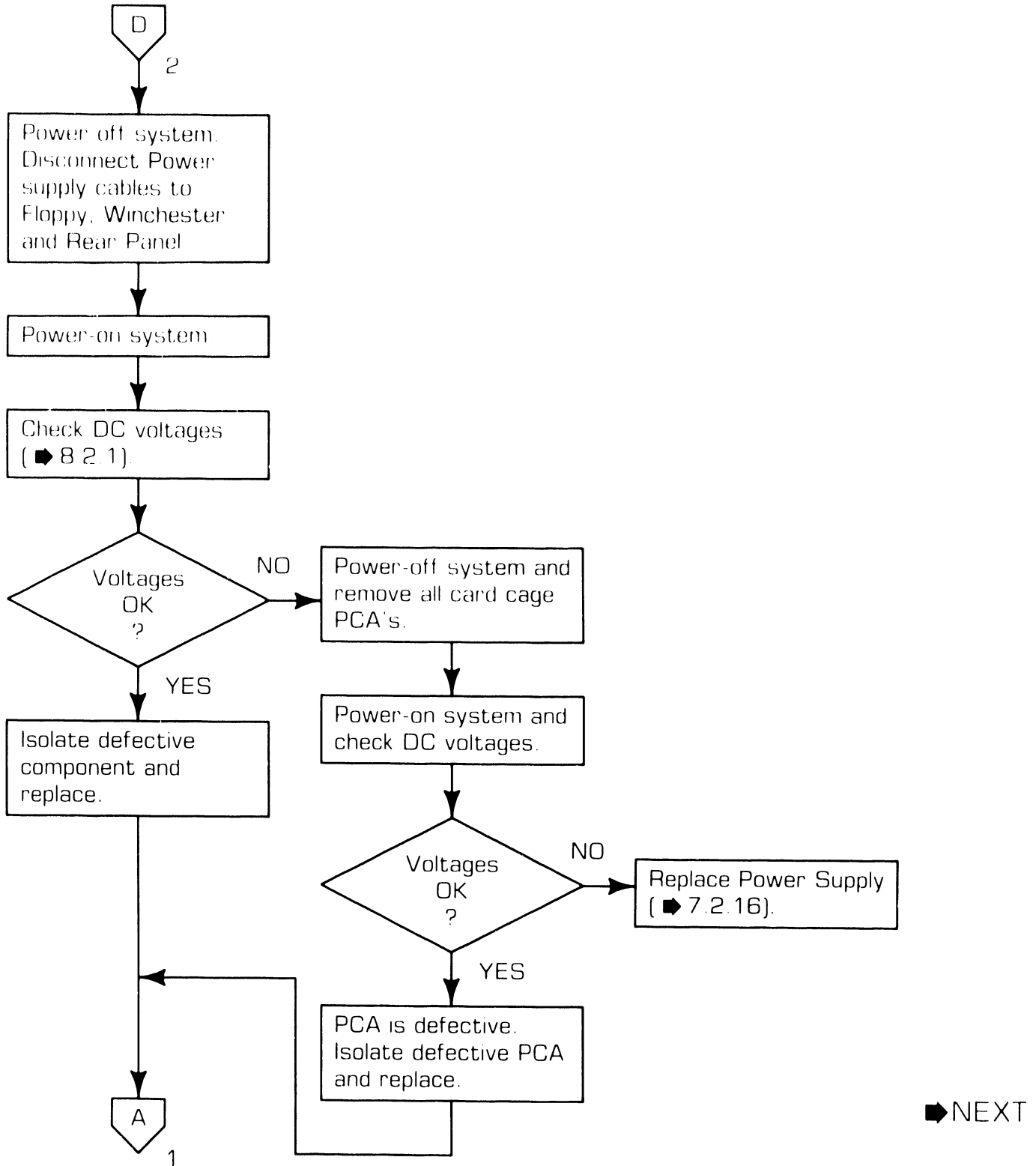

6.5 Troubleshooting Flowcharts

6.5.1 Power-Up Procedure (Sheet 4 of 6)

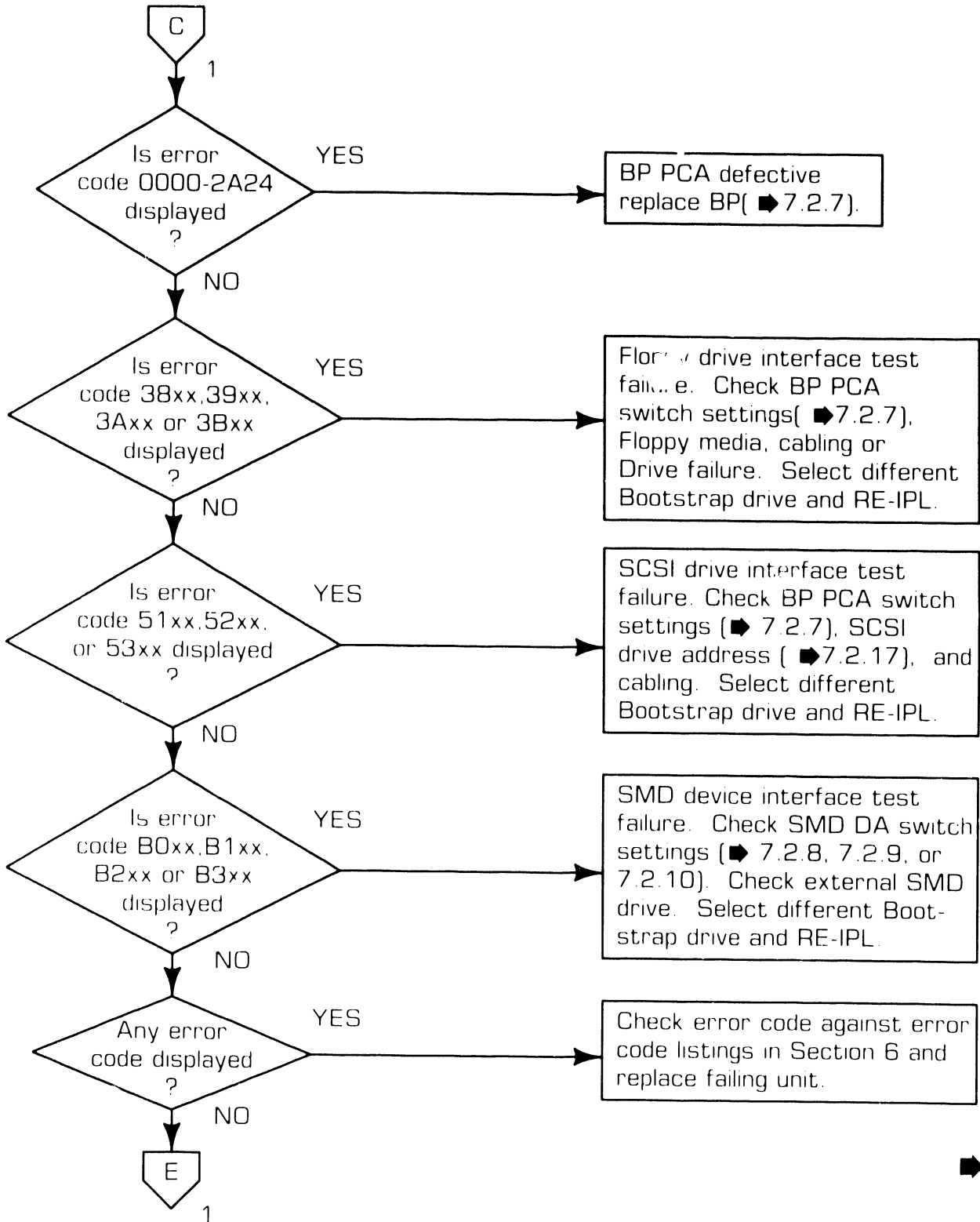

6.5 Troubleshooting Flowcharts

6.5.1 Power-Up Procedure (Sheet 5 of 6)

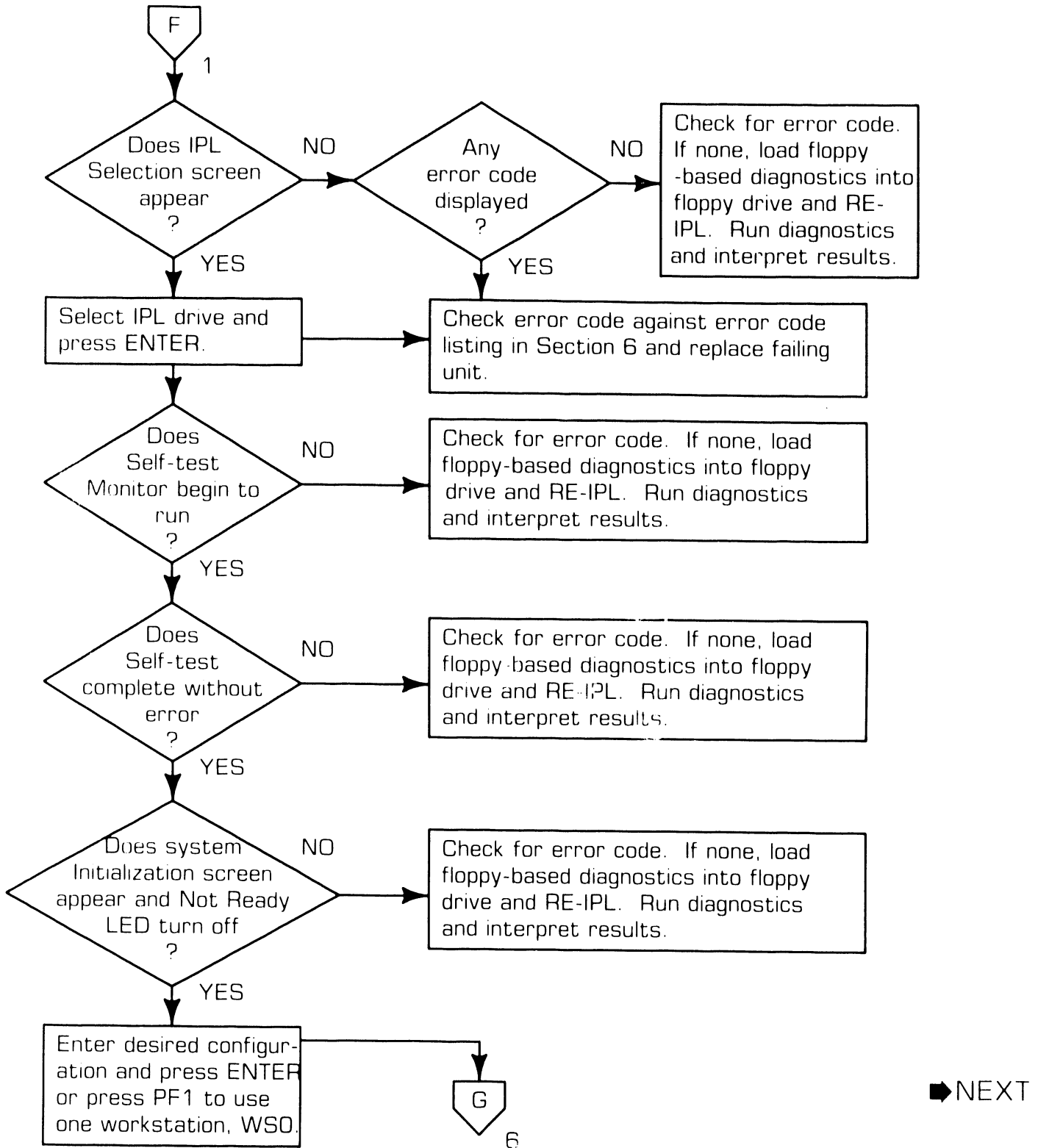

6.5 TROUBLESHOOTING

6.5.1 Power-Up Procedure (Sheet 6 of 6)

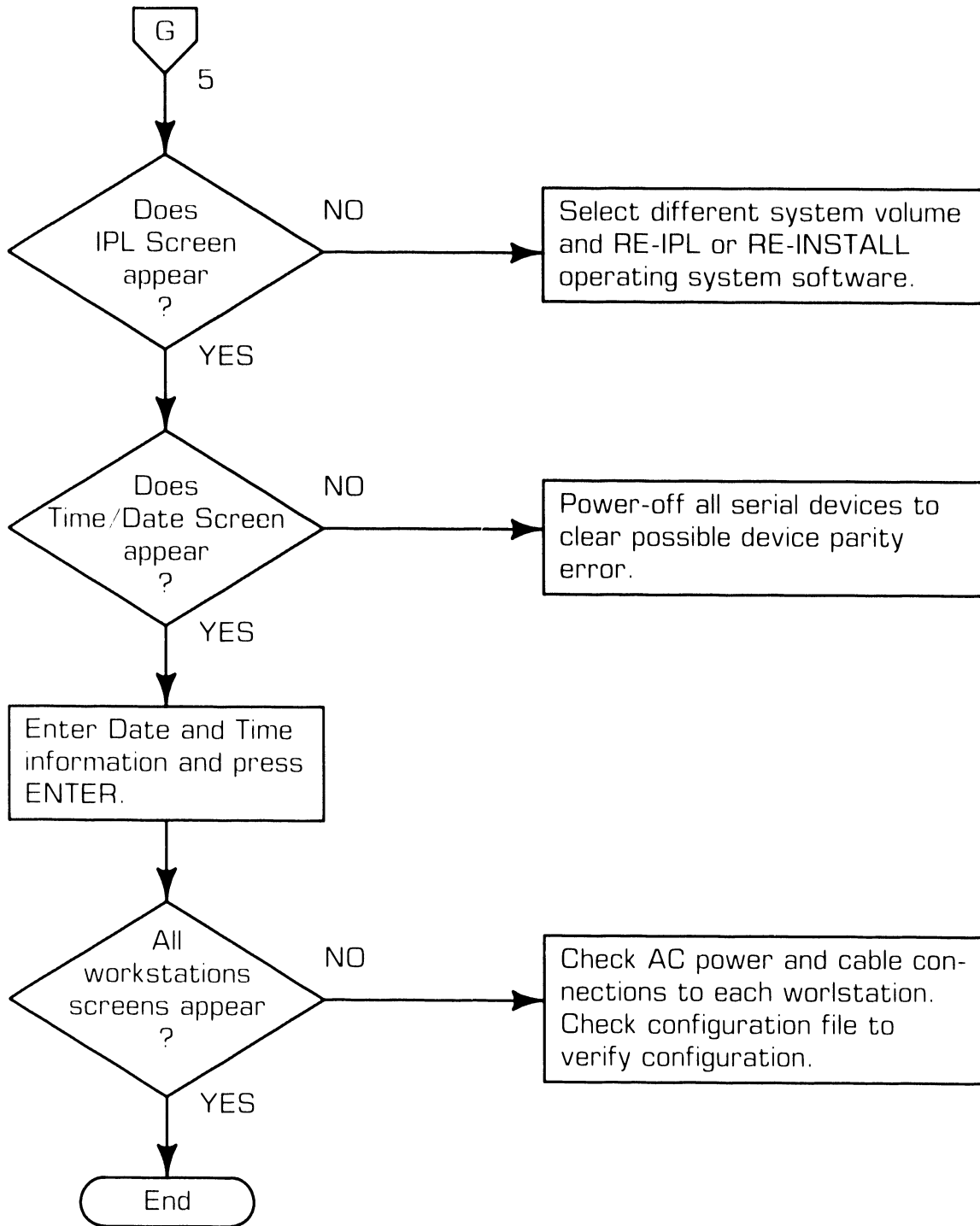

● END

SECTION

7

REPAIR

SECTION 7 CONTENTS

SECTION 7 REPAIR

	<u>Page</u>
7.1 TOOLS AND TEST EQUIPMENT	7-1
7.2 REMOVAL PROCEDURES	7-2
7.2.1 Top Cover Removal	7-2
7.2.2 Front Cover Removal	7-3
7.2.3 Side Covers Removal	7-4
7.2.4 General PCB Removal	7-5
7.2.5 Main Memory Board Removal	7-7
7.2.6 Central Processor Board Removal	7-10
7.2.7 Bus Processor Board (BP) Removal	7-11
7.2.8 SMD 2-Port Board (25V50-2) Removal	7-16
7.2.9 SMD 4-Port Board (25V50-4) Removal	7-19
7.2.10 High-Speed 4-Port Board (25V98-4) Removal	7-22
7.2.11 1-Port TC Controller (25V76-1) Removal	7-25
7.2.12 2-Port TC Controller (25V76-2) Removal	7-28
7.2.13 UISIO Controller (25V67) Removal	7-31
7.2.14 RSF Controller (25V14) Removal	7-34
7.2.15 Async Controller (25V36) Removal	7-38
7.2.16 Power Supply Removal	7-41
7.2.17 Winchester Drive Removal	7-45
7.2.18 Floppy Drive Removal	7-51
7.2.19 Keylock Assembly Removal	7-54
7.2.20 Front Panel Removal	7-55
7.2.21 TC Light Panel Removal	7-56
7.2.22 Motherboard Removal	7-57
7.2.23 Half-Panel Removal	7-60
7.2.24 SCSI Interface Cable Removal	7-62
7.2.25 Dc Fan Assembly Removal	7-63

7.1 Tools And Test Equipment

REPAIR

No special tools or test equipment are required to repair the VS-75E Computer system. All necessary repair can be accomplished using the Wang CE tool kit (WLI# 726-9401).

◆ END

7.2 Removal Procedures

REPAIR

7.2.1 Top Cover Removal

- 1 Power off the VS-75E and disconnect ac power.
(▶ 4.2)

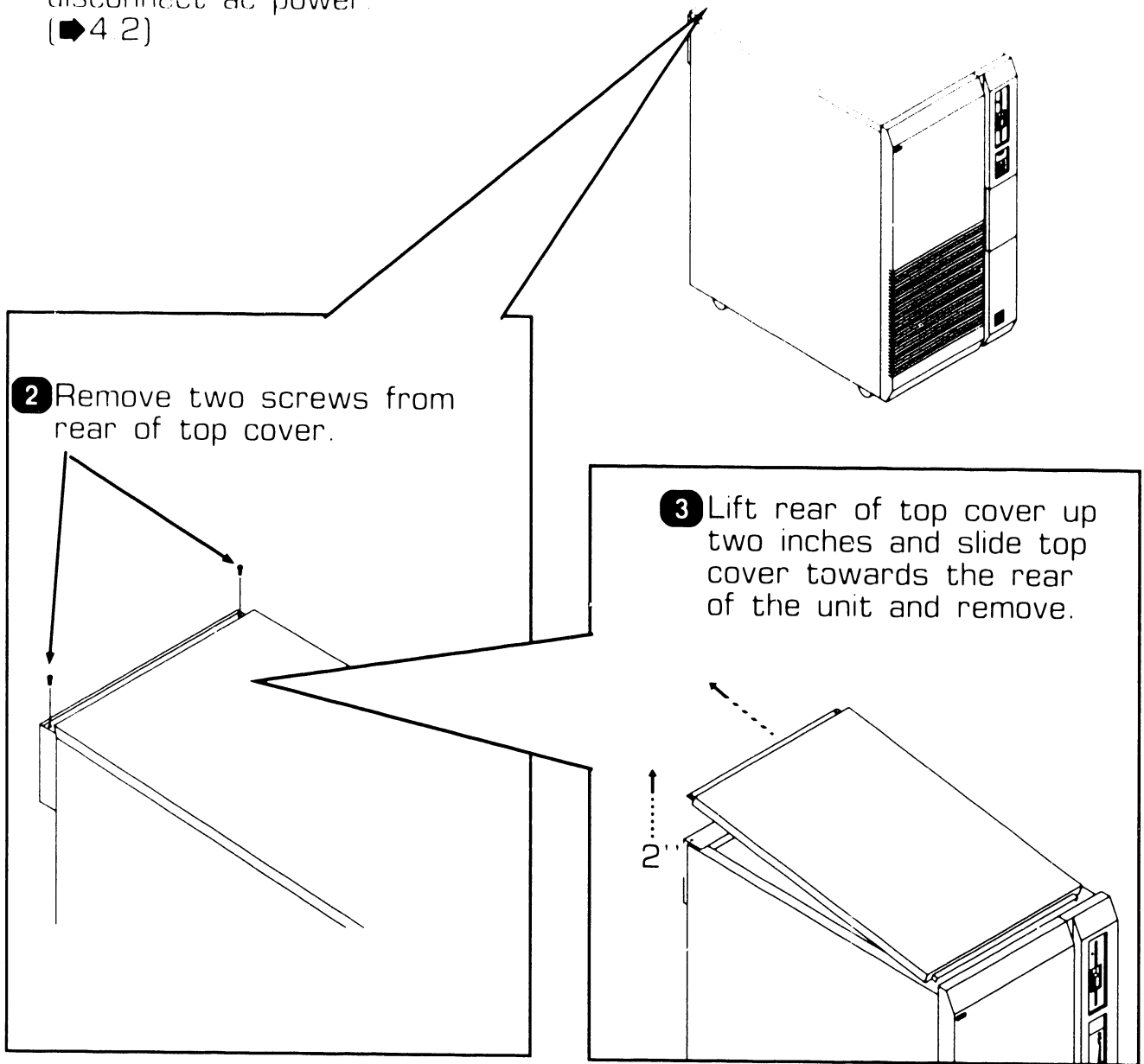

● END

7.2 Removal Procedures

REPAIR

7.2.2 Front Cover Removal

- 1 Power-off the VS-75E and disconnect ac power. (➡ 7.2)
- 2 Remove top cover. (➡ 7.2.1)

- 3 Loosen two screws securing front cover. Tilt front cover forward enough to clear screws and lift cover off.

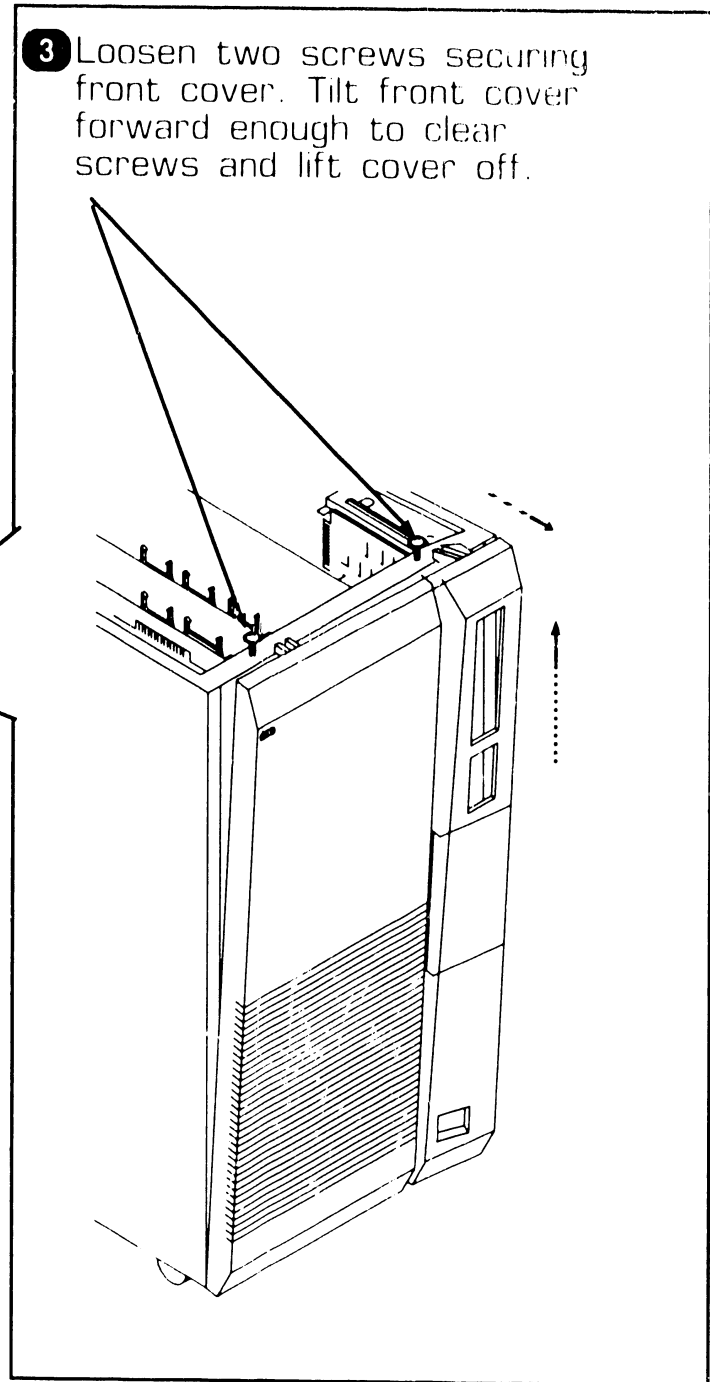
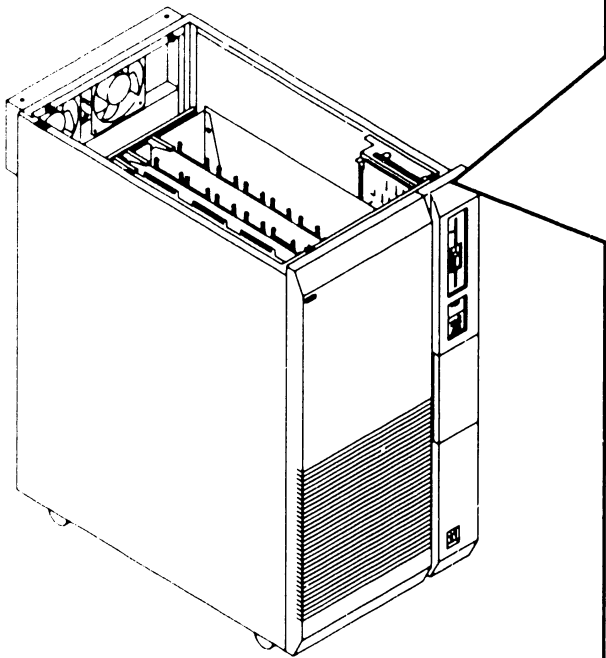

● END

7.2 Removal Procedures

REPAIR

7.2.3 Side Covers Removal

- 1 Power-off the VS-75E and disconnect ac power. (▶4.2)
- 2 Remove top cover. (▶7.2.1)
- 3 Remove front cover. (▶7.2.2)

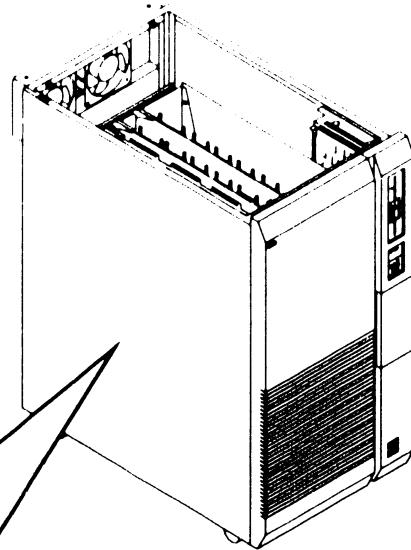

- 4 Lift side cover upward two inches to disengage panel tabs and remove.

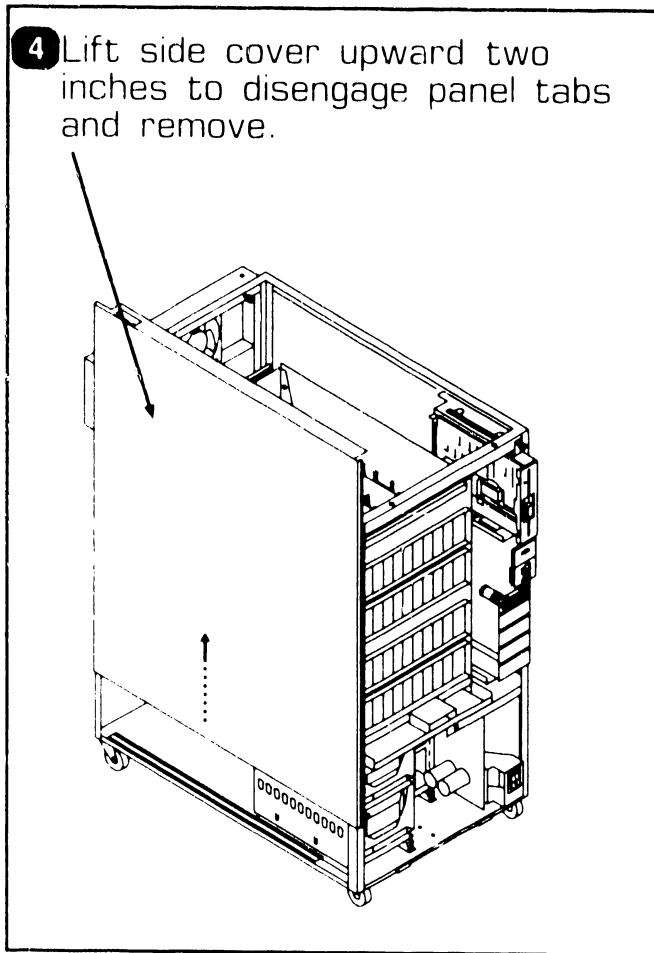

● END

7.2 Removal Procedures

REPAIR

7.2.4 General PCB Removal (Sheet 1 of 2)

- 1 Power-off the VS-75E and disconnect ac power. (▶4.2)
- 2 Remove top cover. (▶7.2.1)
- 3 Remove front cover. (▶7.2.2)

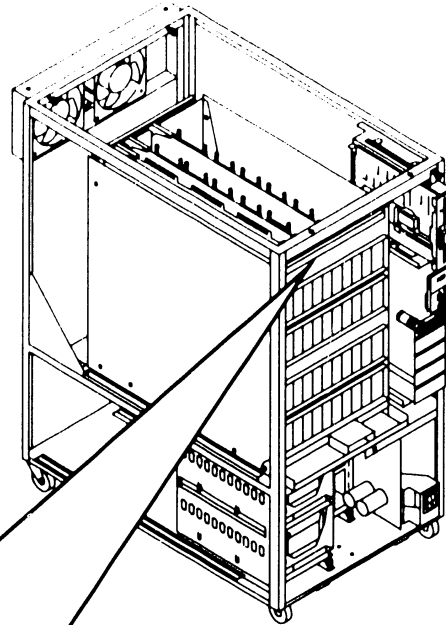

- 4 Remove two screws securing PCB Holddown Device to cardcage.

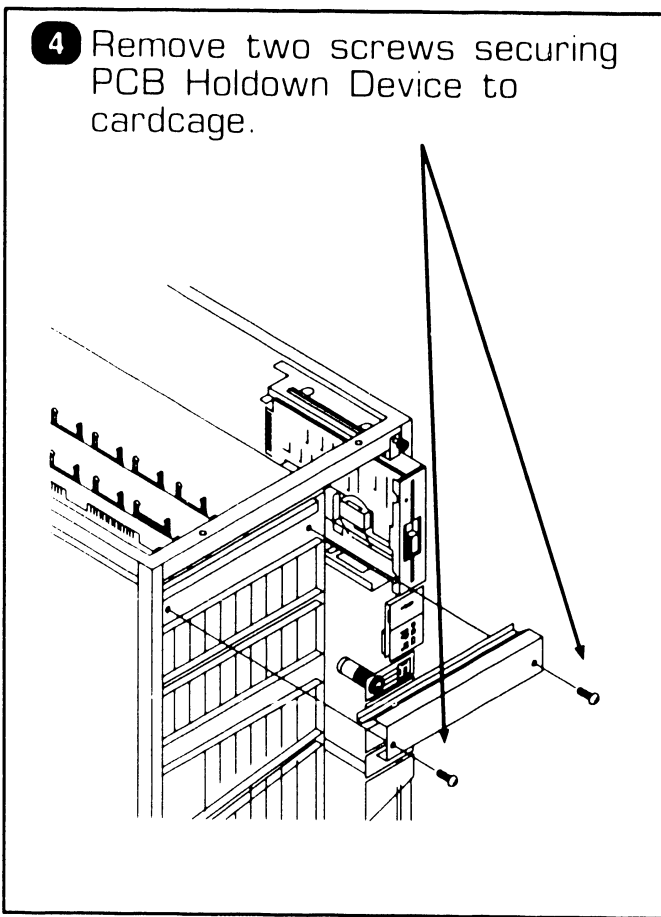

▶NEXT

7.2 Removal Procedures

REPAIR

7.2.4 General PCB Removal (Sheet 2 of 2)

- 5 Note cable routing and location and remove cables from PCB connectors.

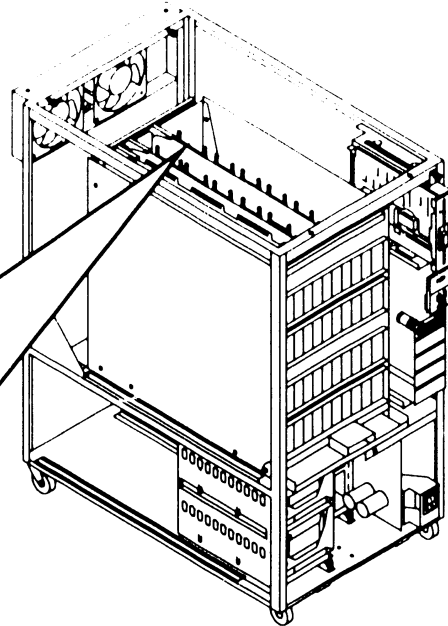

- 6 Position PCA lever clamps to open position by pulling clamp away from board.

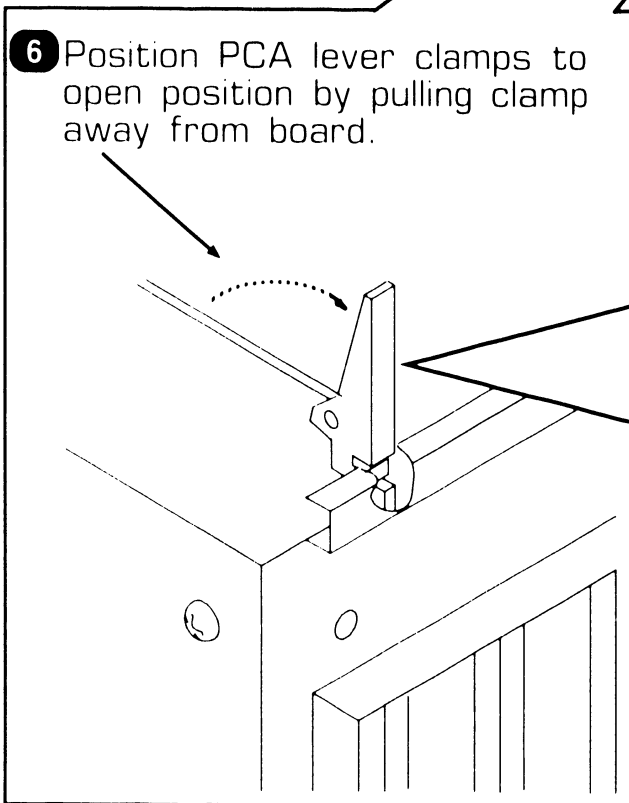

- 7 Pull board out of card cage by sliding on guide rails.

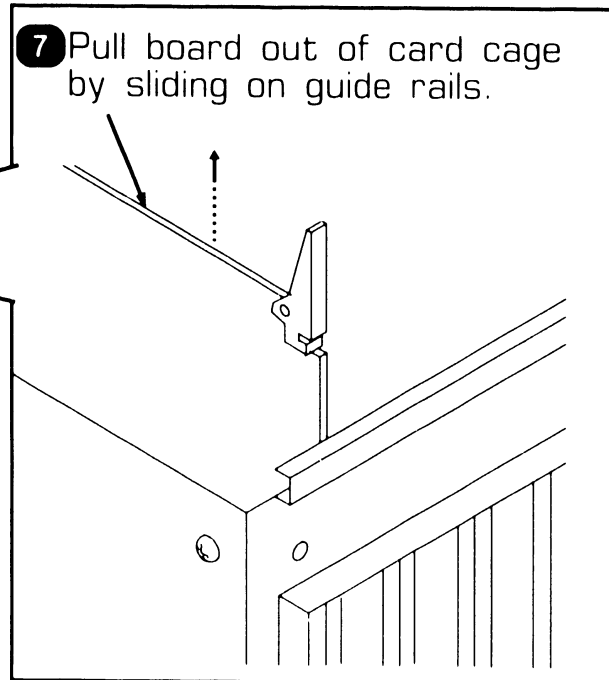

● END

7.2 Removal Procedures

REPAIR

7.2.5 Main Memory Board Removal (Sheet 1 of 3)

- 1 Power off the VS 75E and disconnect ac power. (➡4.2)
- 2 Remove top cover. (➡7.2.1)
- 3 Remove PCB Holddown device. (➡7.2.4)

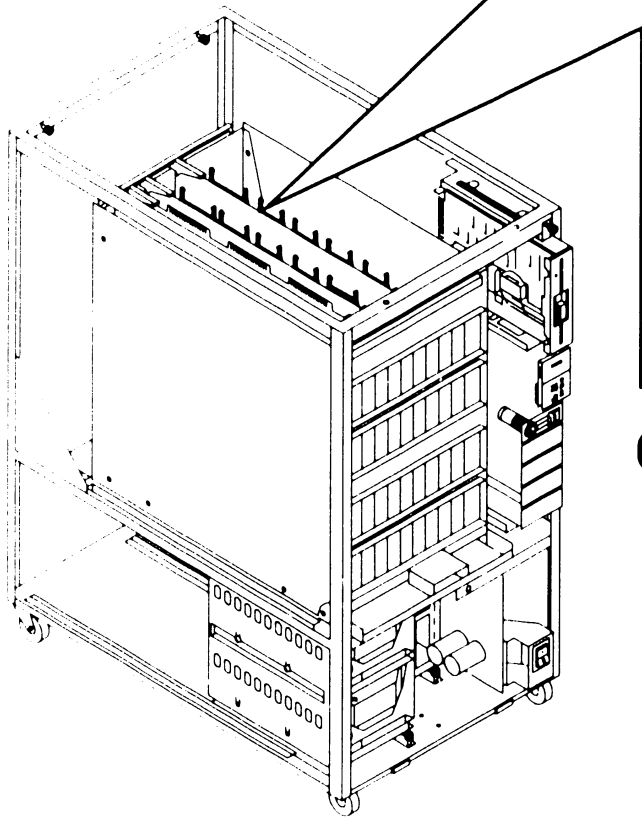
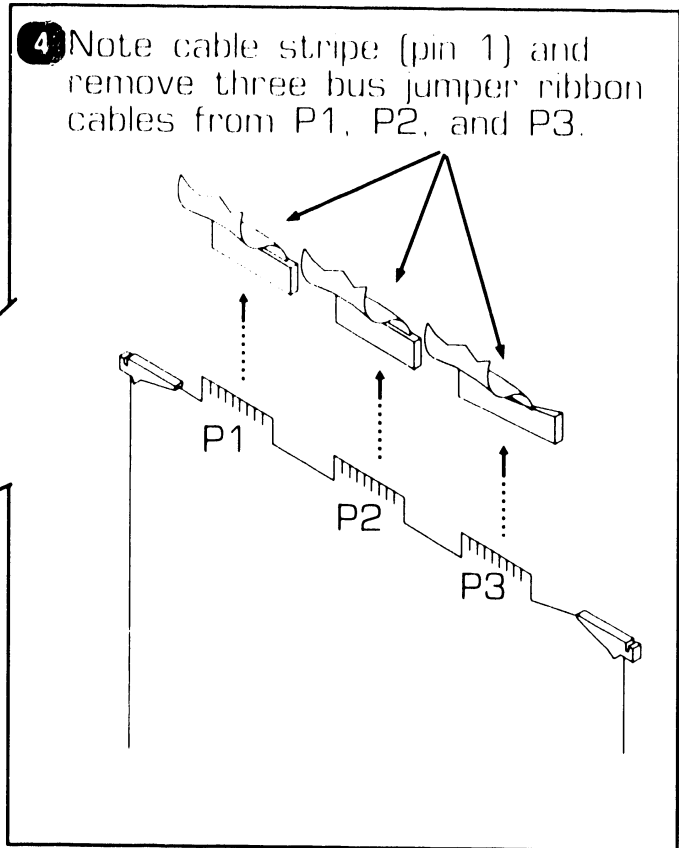

- 5 Remove Main Memory board from card cage. (➡7.2.4)

➡NEXT

7.2 Removal Procedures

7.2.5 Main Memory Board Removal (Sheet 2 of 3)

6 Verify memory SIMMs devices used. 256K devices are labeled "256" and 1M devices are labeled "1024".

JP1
SW1

7 Verify proper Jumper JP1 position for 256K SIMMs memory devices.

8 Verify switch SW1 for memory size setting for 256K SIMMs memory devices used.

2 MEG
210-9094-A

<input checked="" type="checkbox"/>	1	x
<input checked="" type="checkbox"/>	2	x
<input checked="" type="checkbox"/>	3	x
<input type="checkbox"/>	4	o
<input checked="" type="checkbox"/>	5	x
<input checked="" type="checkbox"/>	6	x
<input type="checkbox"/>	7	o
<input type="checkbox"/>	∞	o

4 MEG
210-9094-1A

<input checked="" type="checkbox"/>	1	x
<input checked="" type="checkbox"/>	2	x
<input type="checkbox"/>	3	o
<input checked="" type="checkbox"/>	4	o
<input checked="" type="checkbox"/>	5	x
<input checked="" type="checkbox"/>	6	x
<input type="checkbox"/>	7	o
<input checked="" type="checkbox"/>	∞	o

Switch Position
 x Contacts Closed
 o Contacts Open

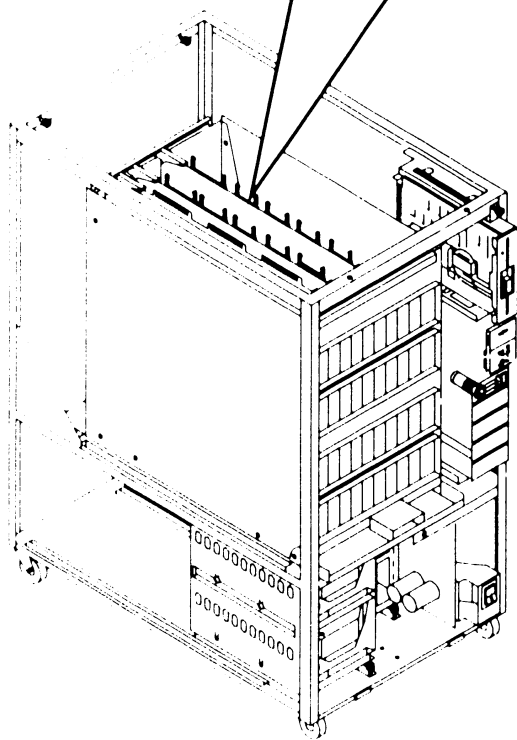

➡ NEXT

7.2 Removal Procedures

REPAIR

7.2.5 Main Memory Board Removal (Sheet 3 of 3)

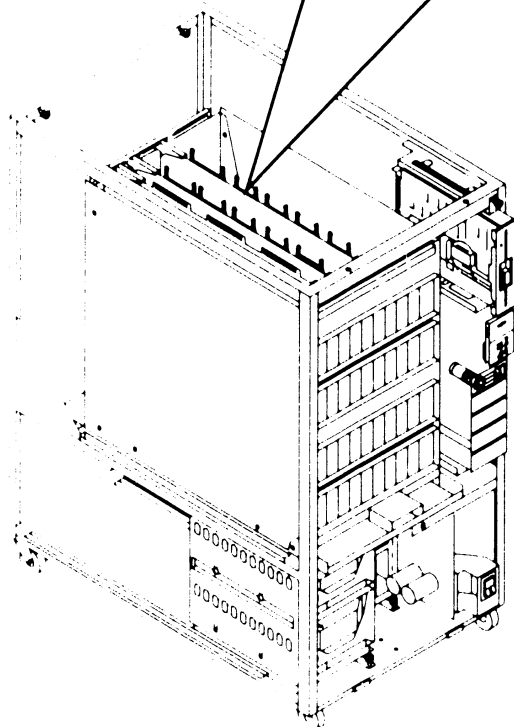
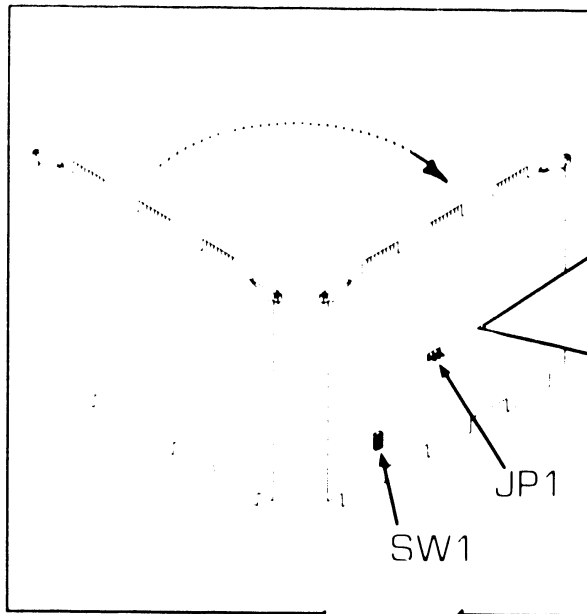

9 Verify proper Jumper JP1 position for 1M SIMMs memory devices

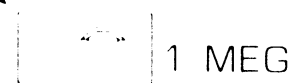

10 Verify switch SW1 for memory size setting for 1M SIMMs memory devices used.

8 MEG
210-9094-2A

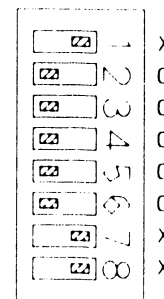

Switch Position
 x Contacts Closed
 o Contacts Open

● END

7.2 Removal Procedures

REPAIR

7.2.6 Central Processor Board (CPU) Removal

- 1 Power-off the VS-75E and disconnect ac power. (➡4.2)
- 2 Remove top cover. (➡7.2.1)
- 3 Remove PCB Holddown device. (➡7.2.4)

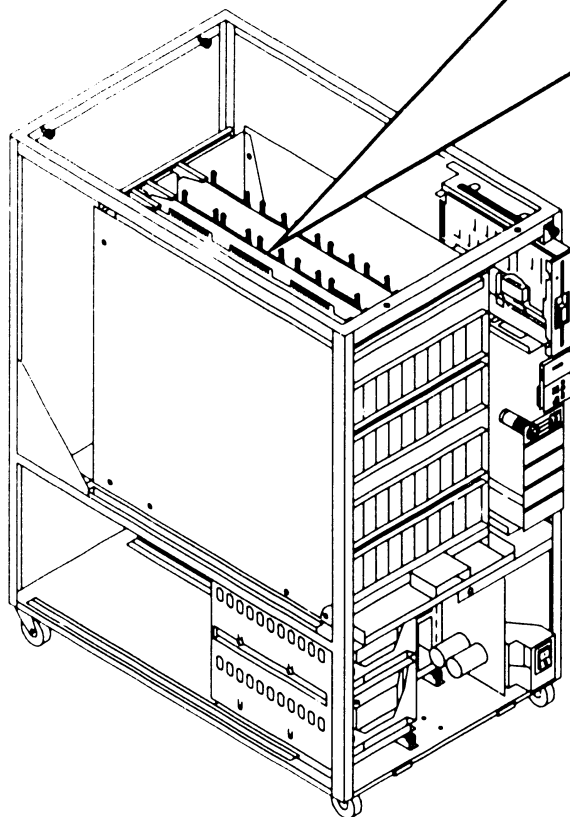
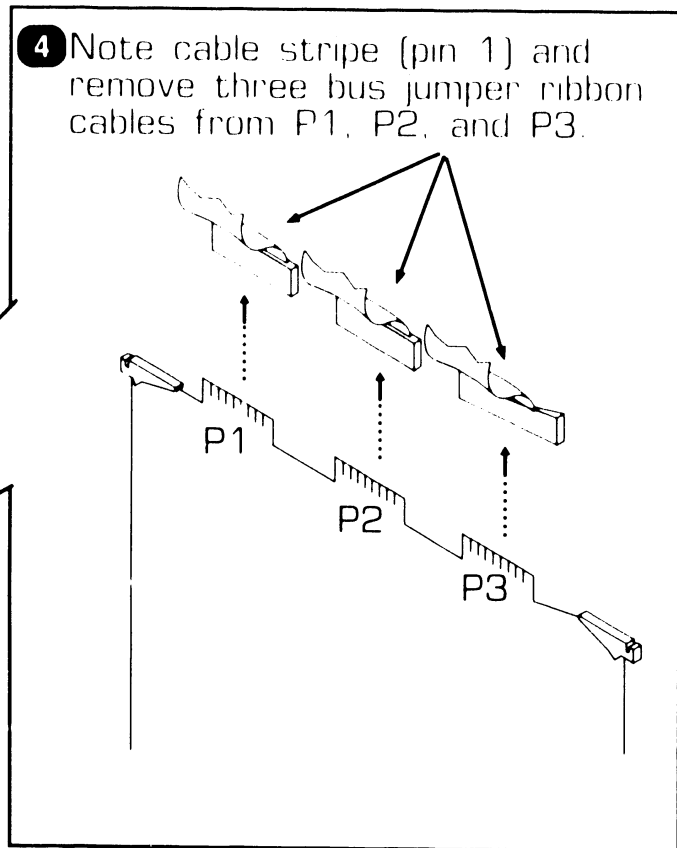

- 5 Remove CPU board from card cage. (➡7.2.4)

● END

7.2 Removal Procedures

REPAIR

7.2.7 Bus Processor Board (BP) Removal (Sheet 1 of 5)

- 1 Power off the VS-75E and disconnect ac power. (➡4.2)
- 2 Remove top cover. (➡7.2.1)
- 3 Remove PCB Holddown device. (➡7.2.4)

- 4 Note cable stripe (pin 1) and remove the following cables:
 - a) 34-pin Floppy connector
 - b) 26-pin Remote connector
 - c) 20-pin TC connector
 - d) 34-pin MUX connector
 - e) 50-pin SCSI connector
 - f) 30-pin Front Panel connector

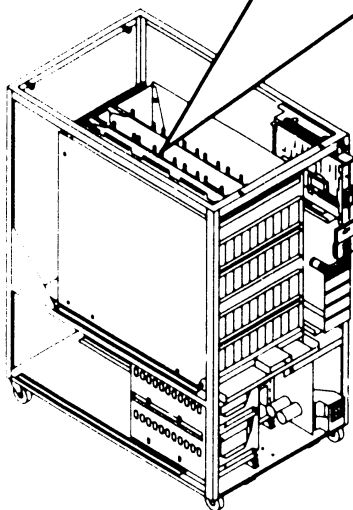
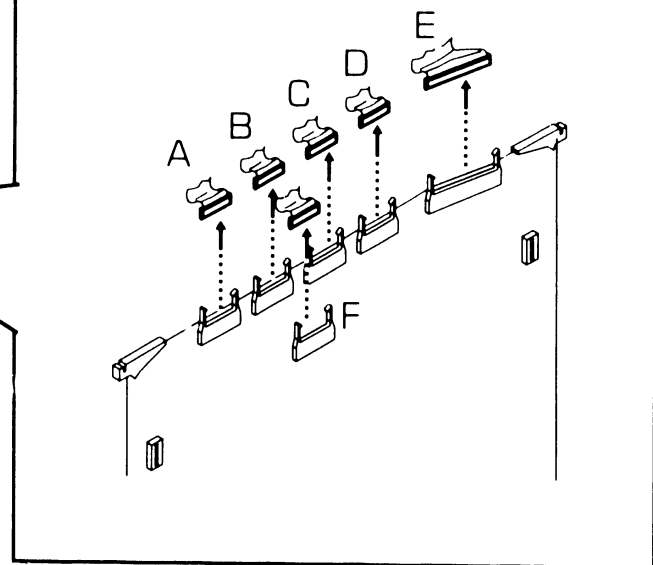
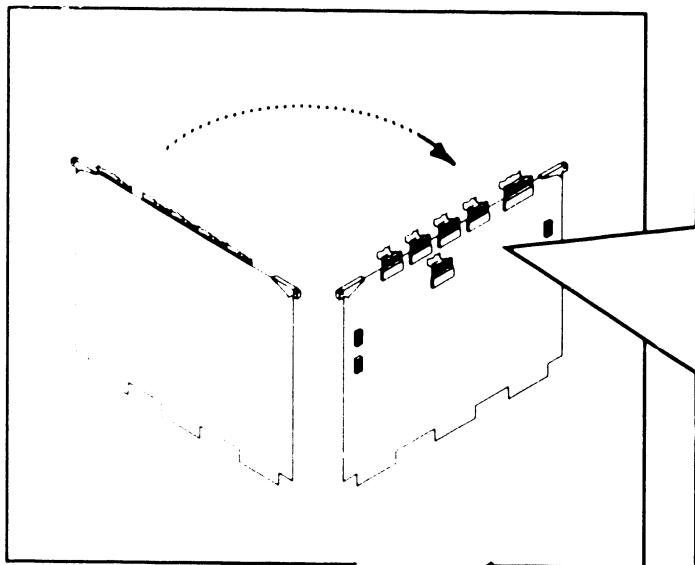

- 5 Remove BP from card cage. (➡7.2.4)

➡NEXT

7.2 Removal Procedures

REPAIR

7.2.7 Bus Processor Board (BP) Removal (Sheet 2 of 5)

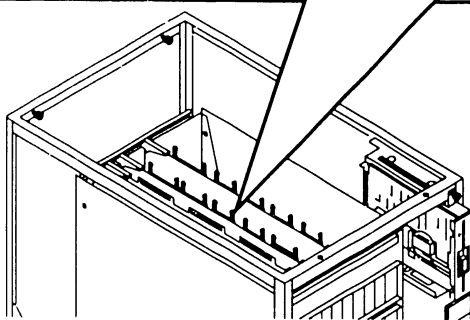
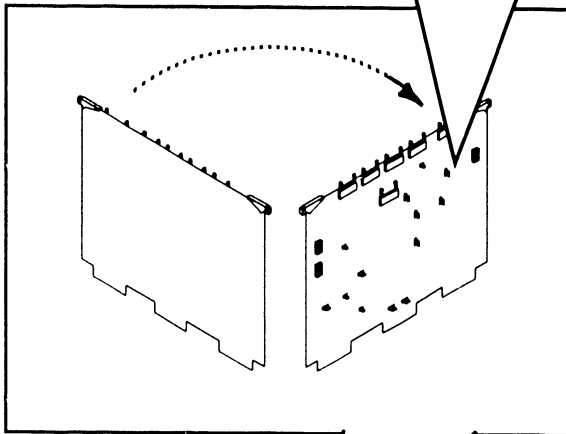
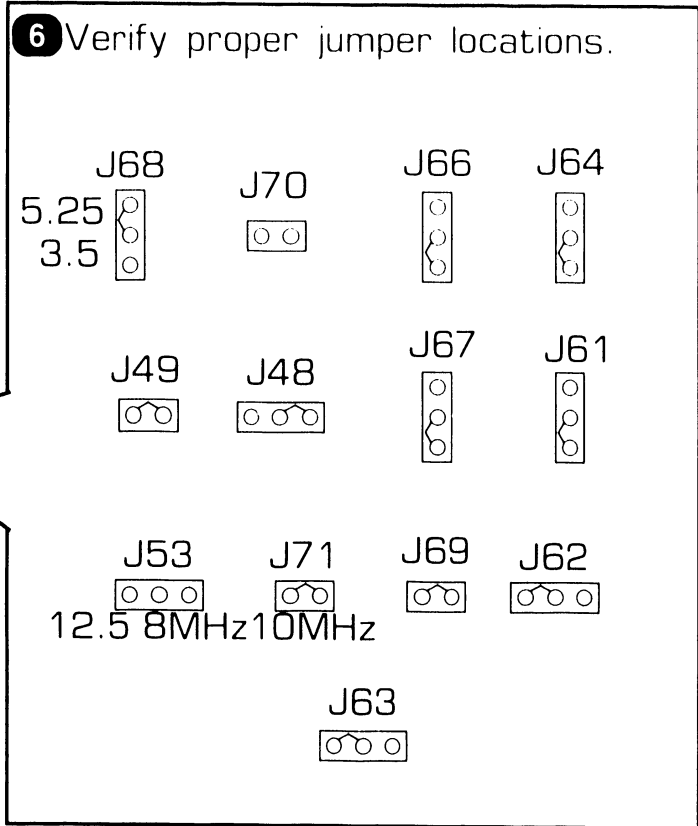
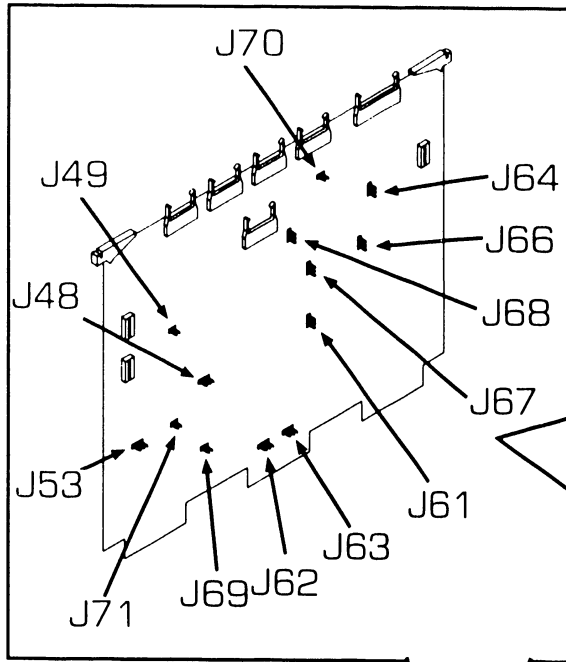

NOTES

1. J70 has jumper removed.
2. J53 used for 12.5 MHz Clock Speed. For 12.5 MHz CPU operation, remove jumper from J71 (10 MHz) and install on J53 (12.5 MHz).

➡ NEXT

7.2 Removal Procedures

REPAIR

7.2.7 Bus Processor Board (BP) Removal (Sheet 3 of 5)

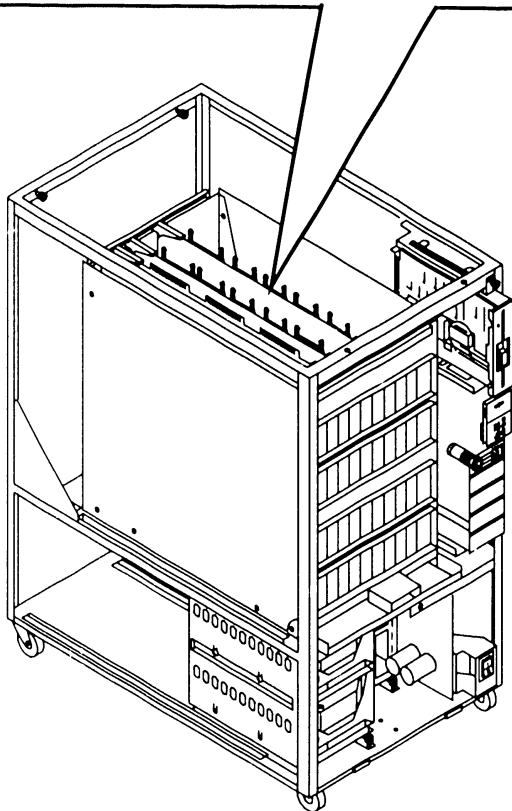
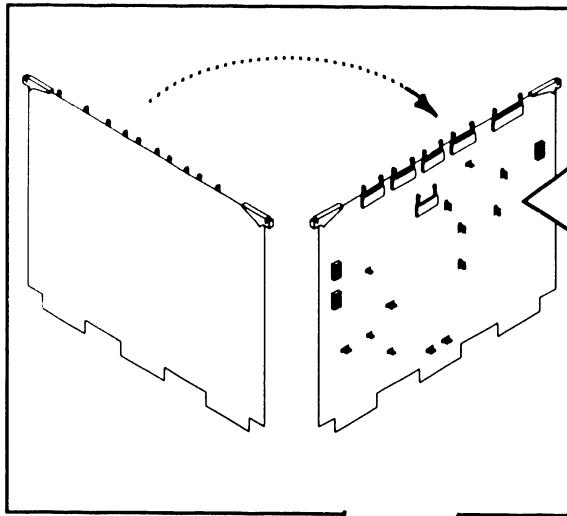

7 Verify proper switch settings (refer to Switch Settings Tables SW1 and SW2 for additional switch setting configurations).

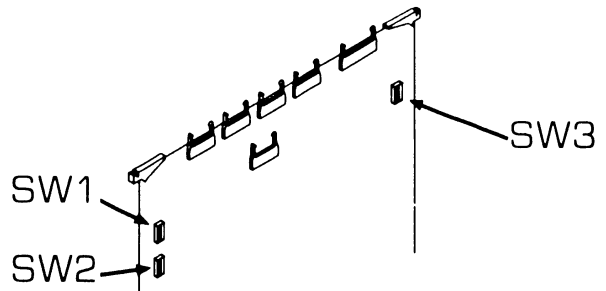

SW1	SW3	10 MHz	12.5 MHz
<input checked="" type="checkbox"/> 1	<input type="checkbox"/> 1	<input checked="" type="checkbox"/> X	<input type="checkbox"/> 0
<input checked="" type="checkbox"/> 2	<input type="checkbox"/> 2	<input checked="" type="checkbox"/> X	<input type="checkbox"/> 0
<input checked="" type="checkbox"/> 3	<input type="checkbox"/> 3	<input checked="" type="checkbox"/> 0	<input type="checkbox"/> X
<input checked="" type="checkbox"/> 4	<input type="checkbox"/> 4	<input checked="" type="checkbox"/> 0	<input type="checkbox"/> X
<input checked="" type="checkbox"/> 5	<input type="checkbox"/> 5	<input checked="" type="checkbox"/> X	<input type="checkbox"/> X
<input checked="" type="checkbox"/> 6	<input type="checkbox"/> 6	<input checked="" type="checkbox"/> 0	<input type="checkbox"/> 0
<input checked="" type="checkbox"/> 7	<input type="checkbox"/> 7	<input checked="" type="checkbox"/> 0	<input type="checkbox"/> 0
<input checked="" type="checkbox"/> 8	<input type="checkbox"/> 8	<input checked="" type="checkbox"/> 0	<input type="checkbox"/> 0

SW2	12.5 MHz	10 MHz
<input checked="" type="checkbox"/> 1	<input type="checkbox"/> 0	<input checked="" type="checkbox"/> X
<input checked="" type="checkbox"/> 2	<input type="checkbox"/> 0	<input type="checkbox"/> 0
<input checked="" type="checkbox"/> 3	<input type="checkbox"/> 0	<input type="checkbox"/> 0
<input checked="" type="checkbox"/> 4	<input type="checkbox"/> 0	<input type="checkbox"/> 0
<input checked="" type="checkbox"/> 5	<input type="checkbox"/> 0	<input type="checkbox"/> 0
<input checked="" type="checkbox"/> 6	<input type="checkbox"/> 0	<input type="checkbox"/> 0
<input checked="" type="checkbox"/> 7	<input type="checkbox"/> 0	<input type="checkbox"/> 0
<input checked="" type="checkbox"/> 8	<input type="checkbox"/> 0	<input type="checkbox"/> 0

= Switch Position
 0 = Contacts Open
 X = Contacts Closed

NOTE

SW2 switch 3 setting must correspond to the clock frequency of the 80186 microprocessor (10 MHz or 12.5 MHz). SW3 must be set according to processor speed.

➡ NEXT

7.2 Removal Procedures

REPAIR

7.2.7 Bus Processor Board (BP) Removal (Sheet 4 of 5)

Table 7-2. VS-75E Bus Processor Switch Bank SW1 Settings.

SW8	SW7	SW6	SW5	SW4	SW3	SW2	SW1	Floppy Drive Type
								Closed Closed - 1.2MB, (Note 1)
								Closed Open - 720KB, (Note 2)
								Open Closed - 1.2MB, (Note 3)
								Open Open - 360KB, 5-1/4 In.
								Internal SCSI Device ID = 6
								Closed Closed - Reserved
								Closed Open - Reserved
								Open Closed - WD-1003A (Note 4)
								Open Open - Self Identifying
								Internal SCSI Device ID = 5
								Closed Closed - Reserved
								Closed Open - Reserved
								Open Closed - WD-1003A (Note 4)
								Open Open - Self Identifying
								Internal SCSI Device ID = 4
								Closed Closed - Reserved
								Closed Open - Reserved
								Open Closed - WD-1003A (Note 4)
								Open Open - Self Identifying

NOTES

1. 1.2MB 3-1/2 inch floppy drive.
2. 720KB 3-1/2 inch floppy drive.
3. 1.2MB 5-1/4 inch floppy drive.
4. WD-1003A is the SCSI-to-ST506 winchester interface controller with 67.5 MB Micropolis drive(s).

➡ NEXT

7.2 Removal Procedures

REPAIR

7.2.7 Bus Processor Board (BP) Removal (Sheet 5 of 5)

Table 7-2. VS-75E Bus Processor Switch Bank SW2 Settings.

SW8	SW7	SW6	SW5	SW4	SW3	SW2	SW1	WSO Location
								Closed Closed - Reserved Closed Open - BP RS232 Port Open Closed - DA Port 0 at Bus Address 400 Open Open - BP 928 Datalink
								80186 Clock Closed - 10 MHz Open - 12.5 MHz
								BIT Error Control Closed- Loop on Error Open - Halt on Error
								BIT Loop Control Closed- Loop on BIT Open - Boot on Successful BIT Completion
								IPL Control Closed N/A - Bypass Power-Up, Load Diagnostic Monitor Open Closed- Bypass Power-Up and Self-Test Open Open - Execute Power-Up and Self-Test, Normal IPL
								IPL Control Enable Closed - Enables Switches 5, 6, and 7 Open - Forces Normal IPL, Ignores Switches 5, 6, and 7

● END

7.2 Removal Procedures

REPAIR

7.2.8 SMD 2-Port Board (25V50-2) Removal (Sheet 1 of 3)

- 1 Power-off the VS-75E and disconnect ac power. (➡4.2)
- 2 Remove top cover. (➡7.2.1)
- 3 Remove PCB Holdown device. (➡7.2.4)

- 4 Note cable stripe (pin 1) and remove the following cables:
 - a) 50-pin A-Cable connector J1
 - b) 26-pin B-Cable connectors J2 and J3

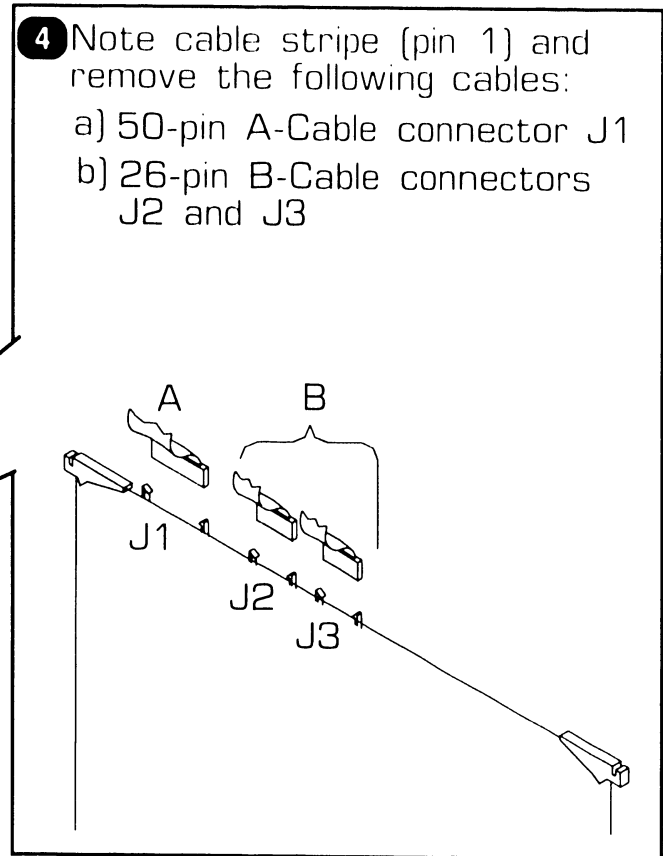
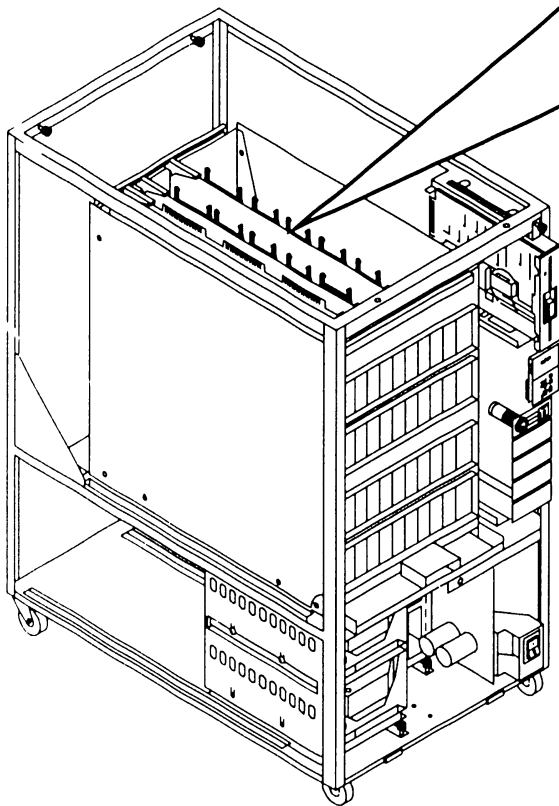

- 5 Remove SMD 2-Port board from card cage. (➡7.2.4)

➡NEXT

7.2 Removal Procedures

REPAIR

7.2.8 SMD 2-Port Board (25V50-2) Removal (Sheet 2 of 3)

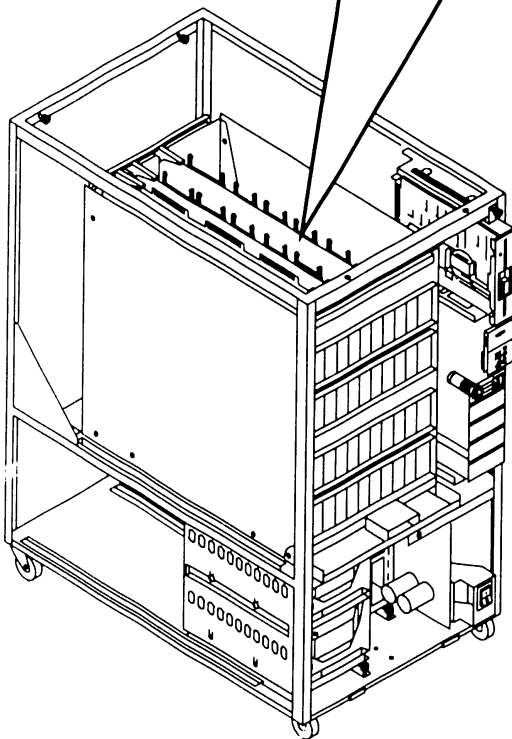
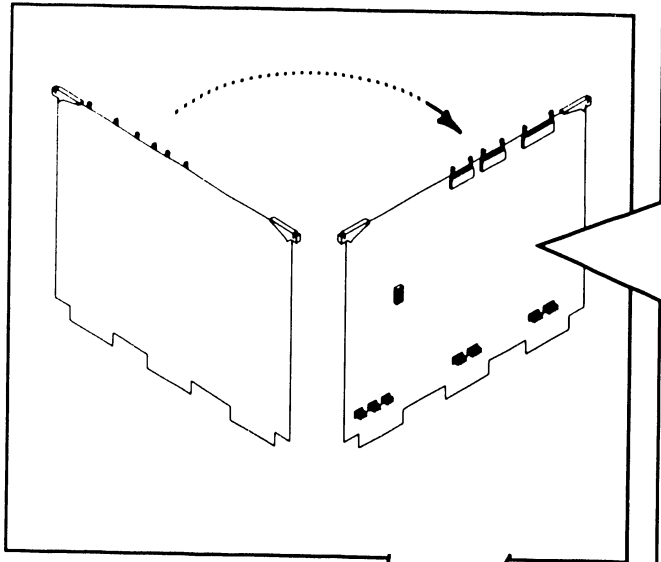

6 Verify proper jumper positions.

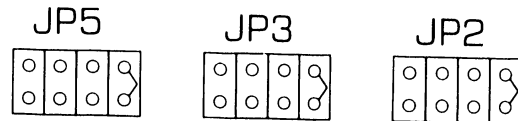
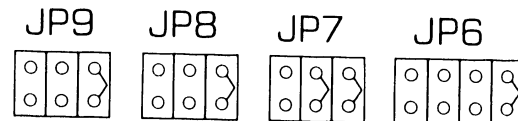
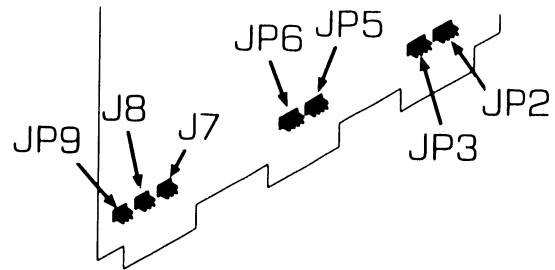

Address 0100

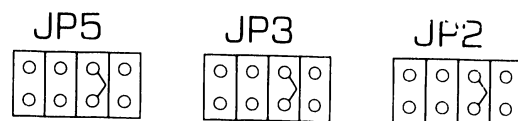
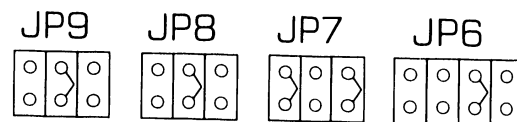

Address 0200

NOTE

Address 0100 is reserved for the primary SMD Controller Board (bootable drive when the Boot Device Switch is EXT mode). Address 0200 is used for the additional SMD Controller.

➡ NEXT

7.2 Removal Procedures

REPAIR

7.2.8 SMD 2-Port Board (25V50-2) Removal (Sheet 3 of 3)

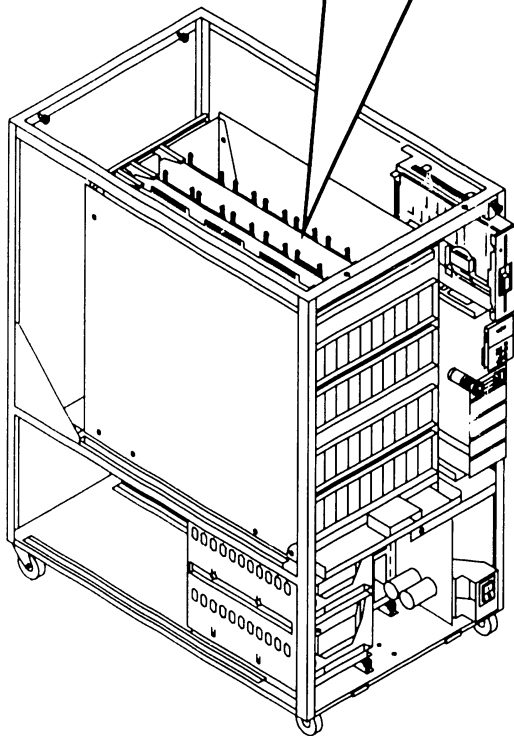
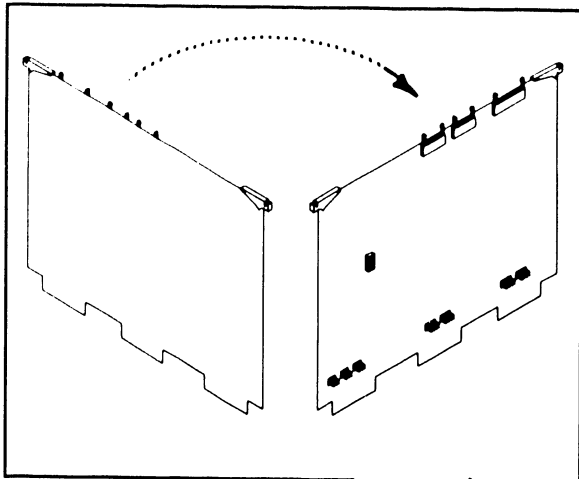

7 Verify proper switch settings for drive-types (or no drive) installed.

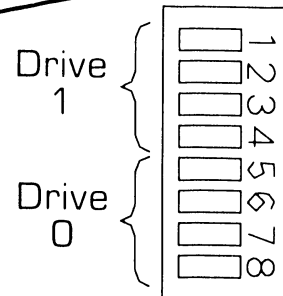
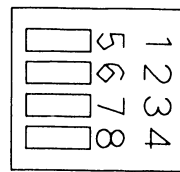
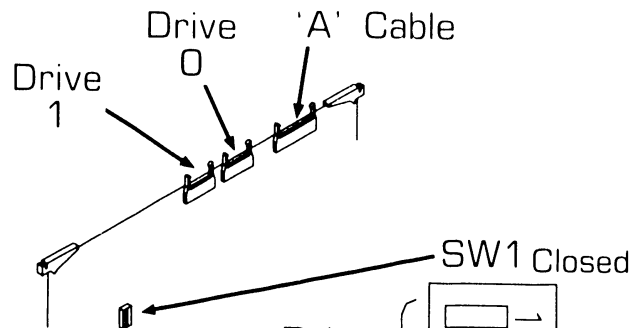

90M CMD	60M CMD	30M CMD	288M SMD	75M CMD	CMD 76M RSD
<input checked="" type="checkbox"/> 0	<input checked="" type="checkbox"/> 0	<input checked="" type="checkbox"/> 0	<input checked="" type="checkbox"/> 0	<input checked="" type="checkbox"/> 0	<input checked="" type="checkbox"/> 0
<input checked="" type="checkbox"/> x	<input checked="" type="checkbox"/> x	<input checked="" type="checkbox"/> x	<input checked="" type="checkbox"/> 0	<input checked="" type="checkbox"/> 0	<input checked="" type="checkbox"/> 0
<input checked="" type="checkbox"/> x	<input checked="" type="checkbox"/> 0	<input checked="" type="checkbox"/> 0	<input checked="" type="checkbox"/> 0	<input checked="" type="checkbox"/> 0	<input checked="" type="checkbox"/> 0
<input checked="" type="checkbox"/> 0	<input checked="" type="checkbox"/> x	<input checked="" type="checkbox"/> 0	<input checked="" type="checkbox"/> x	<input checked="" type="checkbox"/> 0	<input checked="" type="checkbox"/> 0
314M FSD	NO DRIVE	147M NEC	76M NEC	620M FMD	
<input checked="" type="checkbox"/> x	<input checked="" type="checkbox"/> x	<input checked="" type="checkbox"/> x	<input checked="" type="checkbox"/> x	<input checked="" type="checkbox"/> x	
<input checked="" type="checkbox"/> x	<input checked="" type="checkbox"/> x	<input checked="" type="checkbox"/> 0	<input checked="" type="checkbox"/> 0	<input checked="" type="checkbox"/> 0	
<input checked="" type="checkbox"/> 0	<input checked="" type="checkbox"/> x	<input checked="" type="checkbox"/> x	<input checked="" type="checkbox"/> 0	<input checked="" type="checkbox"/> x	
<input checked="" type="checkbox"/> x	<input checked="" type="checkbox"/> x	<input checked="" type="checkbox"/> 0	<input checked="" type="checkbox"/> x	<input checked="" type="checkbox"/> x	

= Switch Position

0 = Contacts Open

X = Contacts Closed

● END

7.2 Removal Procedures

REPAIR

7.2.9 SMD 4-Port Board (25V50-4) Removal (Sheet 1 of 3)

- 1 Power-off the VS-75E and disconnect ac power. (➡4.2)
- 2 Remove top cover. (➡7.2.1)
- 3 Remove PCB Holddown device. (➡7.2.4)

- 4 Note cable stripe (pin 1) and remove the following cables:
 - a) 50-pin A-Cable connector J1.
 - b) 26-pin B-Cable connectors J2, J3, J4 and J5.

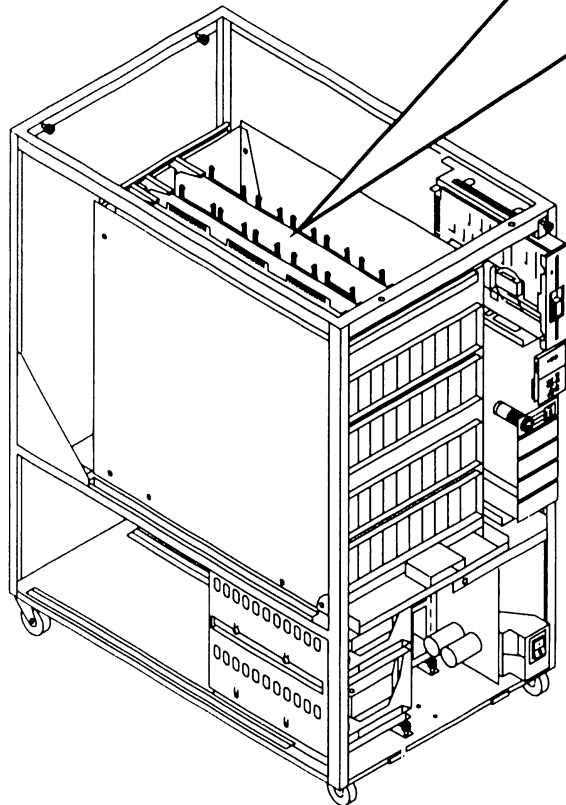
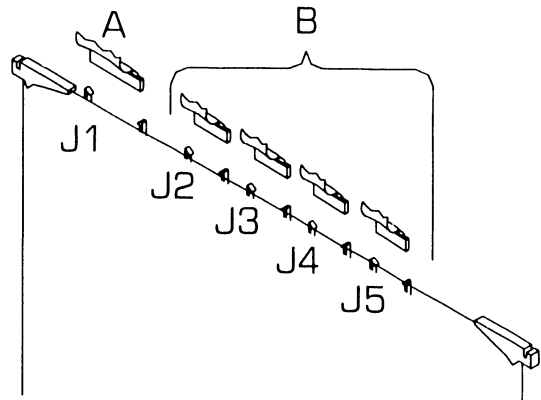

- 5 Remove SMD 4-port board from card cage. (➡7.2.4)

➡NEXT

7.2 Removal Procedures

REPAIR

7.2.9 SMD 4-Port Board (25V50-4) Removal (Sheet 2 of 3)

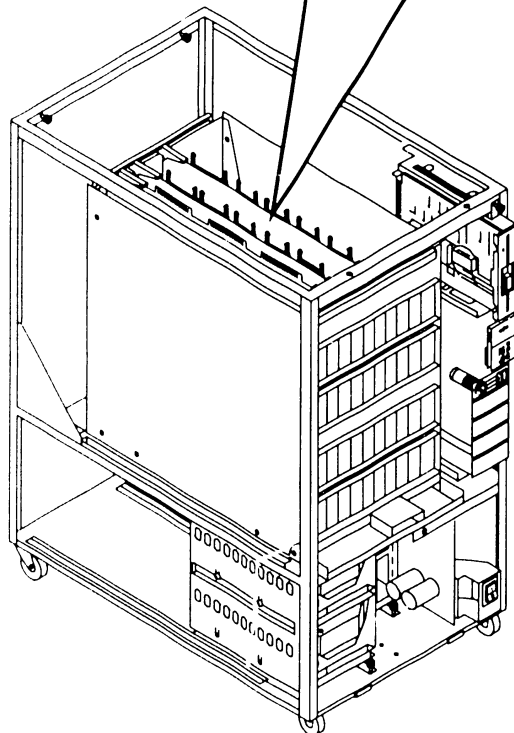
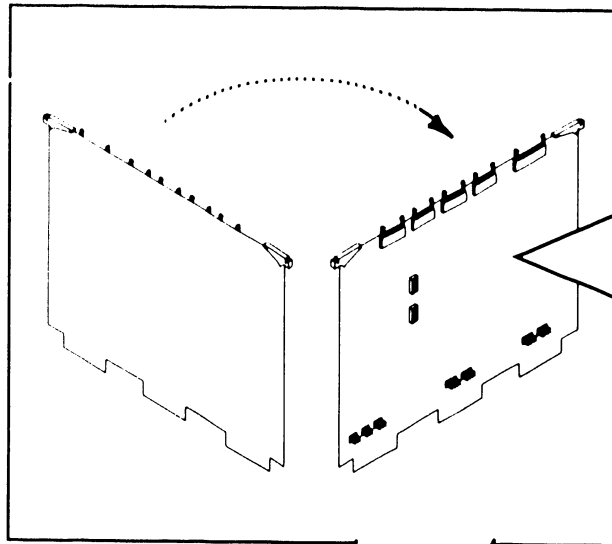

6 Verify proper jumper positions.

JP9	JP8	JP7	JP6
JP5	JP3	JP2	
Address 0100			
JP9	JP8	JP7	JP6
JP5	JP3	JP2	
Address 0200			

NOTE

Address 0100 is reserved for the primary SMD Controller Board (bootable drive when the Boot Device Switch is EXT mode). Address 0200 is used for the additional SMD Controller.

➡NEXT

7.2 Removal Procedures

REPAIR

7.2.9 SMD 4-Port Board (25V50-4) Removal (Sheet 3 of 3)

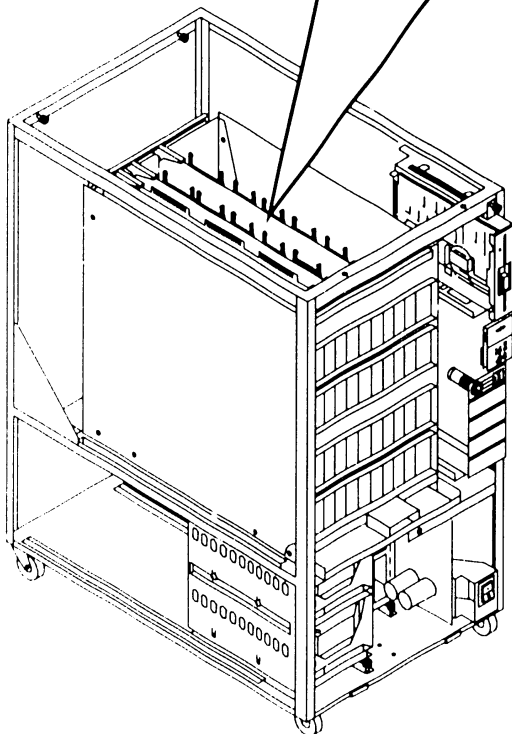
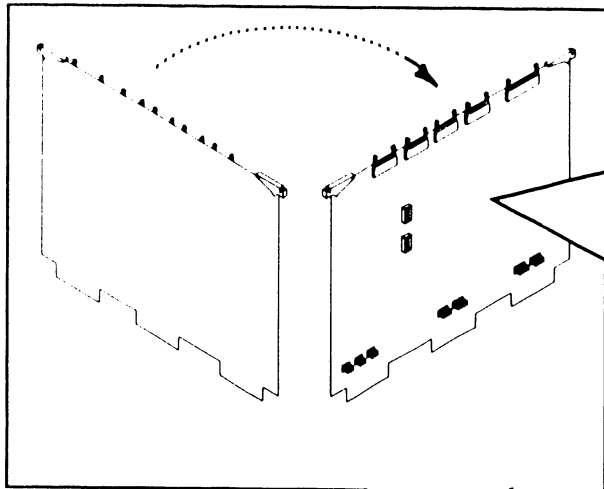

7 Verify proper switch settings for drive-types (or No Drive) installed.

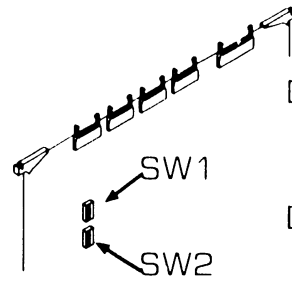

SW1

Drive 1

Drive 0

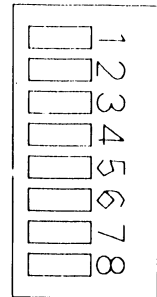

SW2

Drive 3

Drive 2

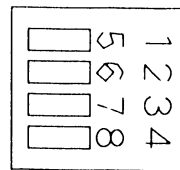
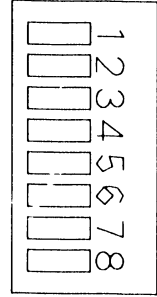

90M CMD	60M CMD	30M CMD	288M SMD	75M SMD	76M RSD
<input checked="" type="checkbox"/> 0	<input checked="" type="checkbox"/> 0	<input checked="" type="checkbox"/> 0	<input checked="" type="checkbox"/> 0	<input checked="" type="checkbox"/> 0	<input checked="" type="checkbox"/> 0
<input checked="" type="checkbox"/> x	<input checked="" type="checkbox"/> x	<input checked="" type="checkbox"/> x	<input checked="" type="checkbox"/> 0	<input checked="" type="checkbox"/> 0	<input checked="" type="checkbox"/> 0
<input checked="" type="checkbox"/> x	<input checked="" type="checkbox"/> 0	<input checked="" type="checkbox"/> 0	<input checked="" type="checkbox"/> 0	<input checked="" type="checkbox"/> 0	<input checked="" type="checkbox"/> 0
<input checked="" type="checkbox"/> 0	<input checked="" type="checkbox"/> x	<input checked="" type="checkbox"/> 0	<input checked="" type="checkbox"/> x	<input checked="" type="checkbox"/> 0	<input checked="" type="checkbox"/> 0

314M FSD	NO DRIVE	147M NEC	76M NEC	620M FMD
<input checked="" type="checkbox"/> x	<input checked="" type="checkbox"/> x	<input checked="" type="checkbox"/> x	<input checked="" type="checkbox"/> x	<input checked="" type="checkbox"/> x
<input checked="" type="checkbox"/> x	<input checked="" type="checkbox"/> x	<input checked="" type="checkbox"/> 0	<input checked="" type="checkbox"/> 0	<input checked="" type="checkbox"/> 0
<input checked="" type="checkbox"/> 0	<input checked="" type="checkbox"/> x	<input checked="" type="checkbox"/> x	<input checked="" type="checkbox"/> 0	<input checked="" type="checkbox"/> x
<input checked="" type="checkbox"/> x	<input checked="" type="checkbox"/> x	<input checked="" type="checkbox"/> 0	<input checked="" type="checkbox"/> x	<input checked="" type="checkbox"/> x

= Switch Position
 0 = Contacts Open
 x = Contacts Closed

● END

7.2 Removal Procedures

REPAIR

7.2.10 High-Speed SMD 4-Port Board (25V98-4) Removal (Sheet 1 of 3)

- 1 Power-off the VS-75E and disconnect ac power. (➡4.2)
- 2 Remove top cover. (➡7.2.1)
- 3 Remove PCB Holddown device. (➡7.2.4)

- 4 Note cable stripe (pin 1) and remove the following cables:
 - a) 50-pin A-Cable connector J1.
 - b) 26-pin B-Cable connectors J2, J3, J4 and J5.

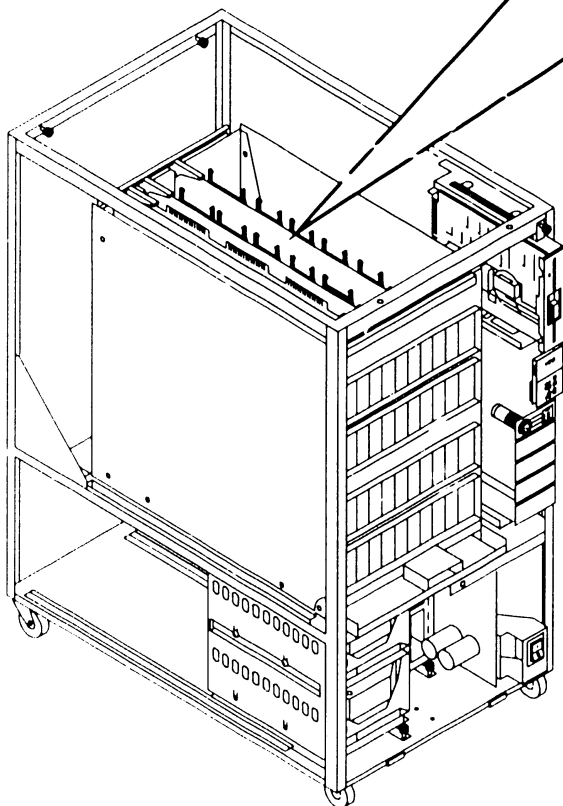
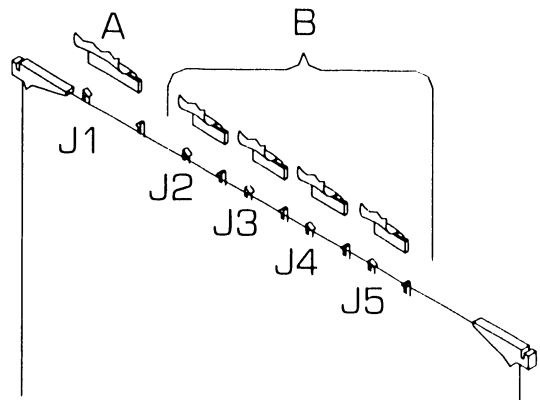

- 5 Remove SMD 4-port board from card cage. (➡7.2.4)

➡NEXT

7.2 Removal Procedures

REPAIR

7.2.10 High-Speed SMD 4-Port Board (25V98-4) Removal (Sheet 2 of 3)

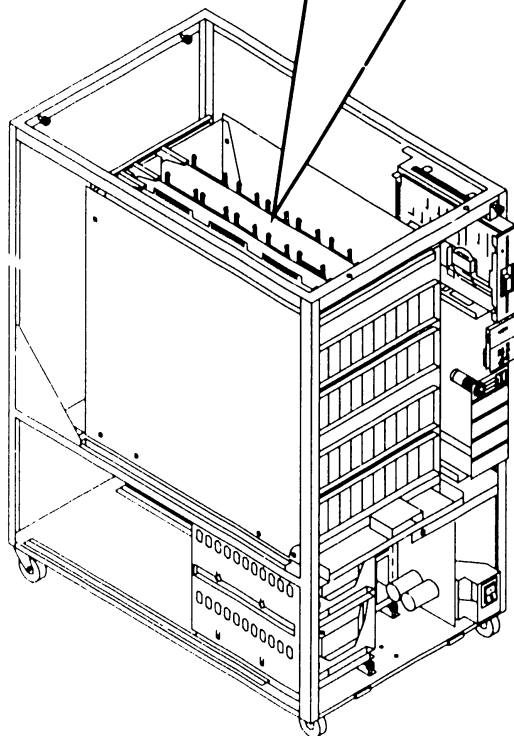
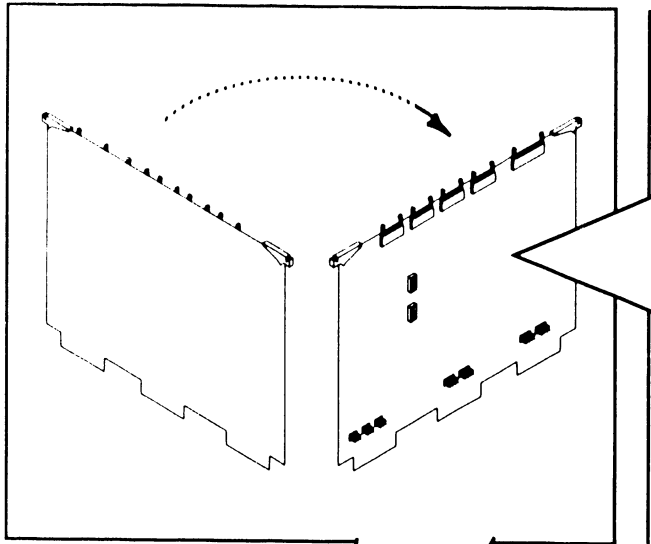

6 Verify proper jumper positions.

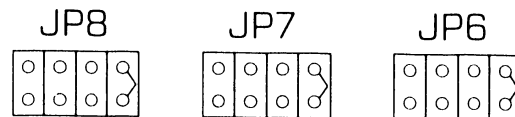
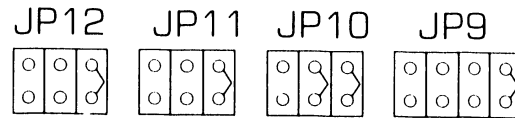
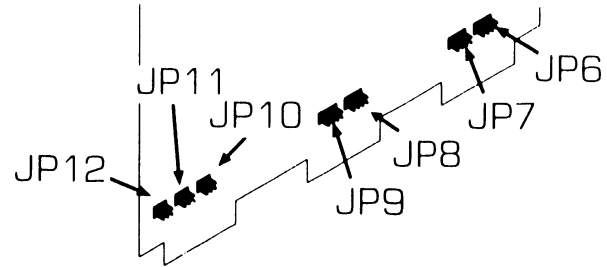

Address 0100

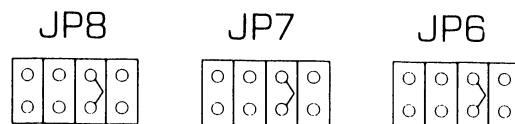
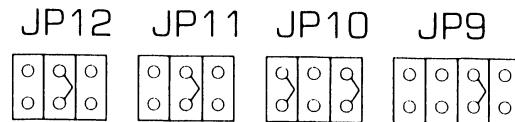

Address 0200

NOTE

Address 0100 is reserved for the primary SMD Controller Board (bootable drive when the Boot Device Switch is EXT mode). Address 0200 is used for the additional SMD Controller.

➡NEXT

7.2 Removal Procedures

REPAIR

7.2.10 High-Speed SMD 4-Port Board (25V98-4) Removal (Sheet 3 of 3)

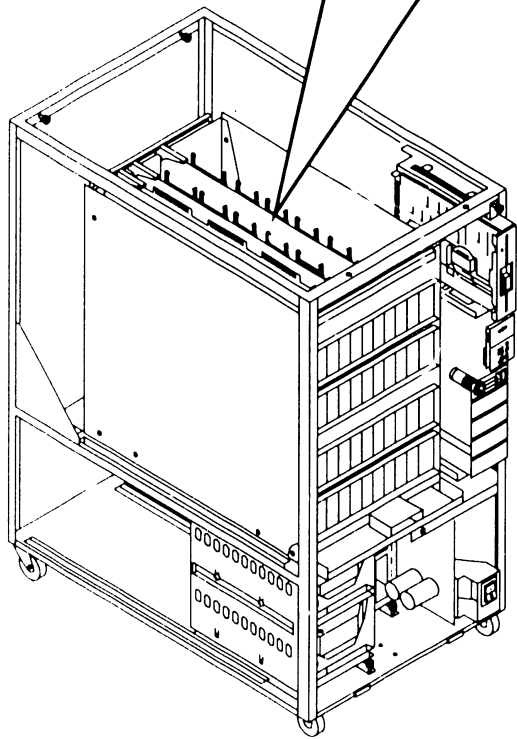
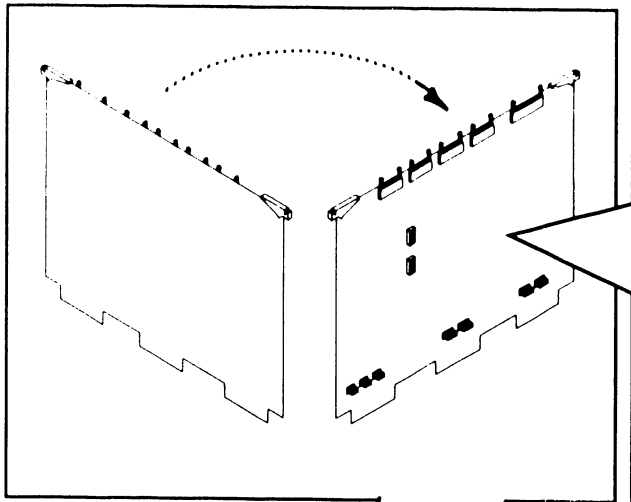

7 Verify proper switch settings for drive-types (or No Drive) installed.

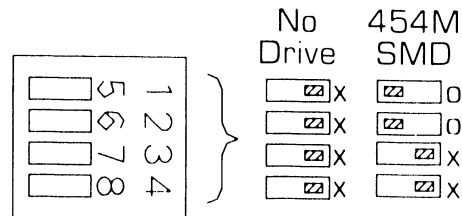
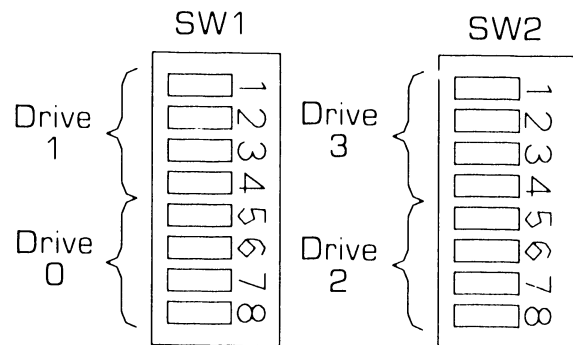
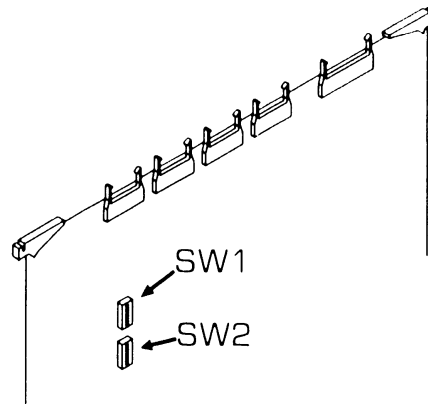

■ = Switch Position
 o = Contacts Open
 x = Contacts Closed

● END

7.2 Removal Procedures

REPAIR

7.2.11 1-Port TC Controller (25V76-1) Removal (Sheet 1 of 3)

- 1 Power-off the VS-75E and disconnect ac power. (➡4.2)
- 2 Remove top cover. (➡7.2.1)
- 3 Remove PCB Holdown device. (➡7.2.4)

NOTE

RS449 Connector J1 is not used.

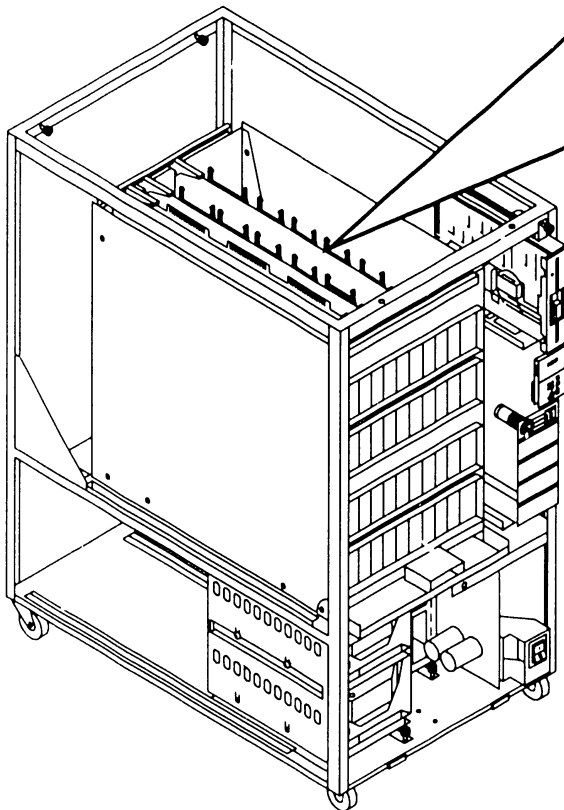

- 4 Note cable stripe (pin 1) and remove the following cables:

- a) 20-pin Light Panel Connector J4.
- b) RS366 Connector J3.
- c) RS232 Connector J2.
- d) X.21 Connector J13.

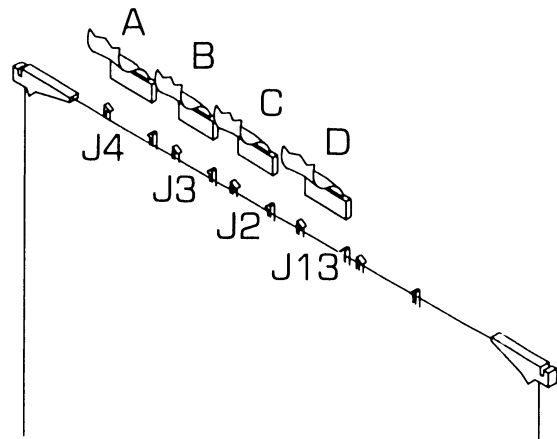

- 5 Remove 1-port TC board from card cage. (➡7.2.4)

➡NEXT

7.2 Removal Procedures

REPAIR

7.2.11 1-Port TC Controller (25V76-1) Removal (Sheet 2 of 3)

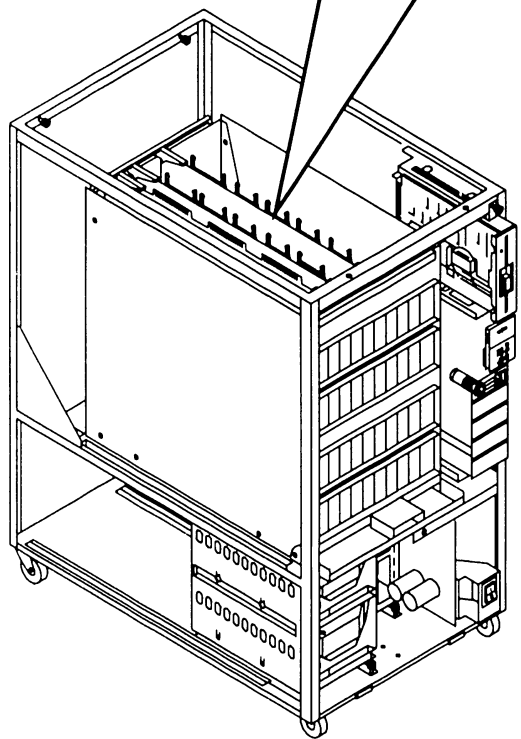
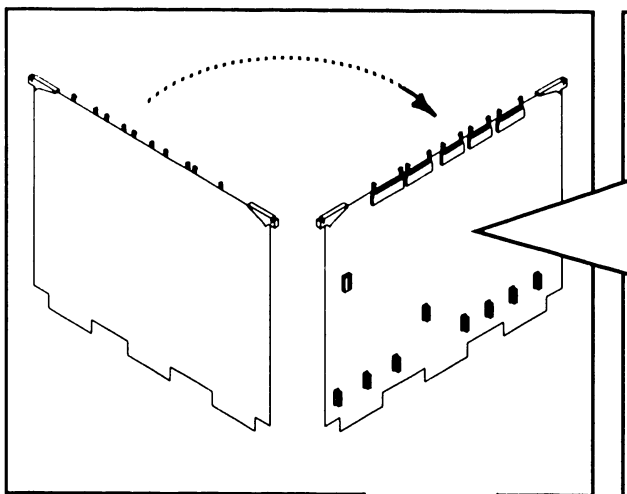

6 Verify proper switch settings for normal operation.

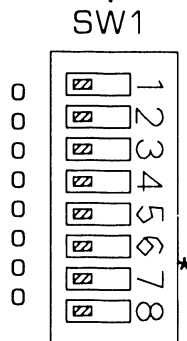
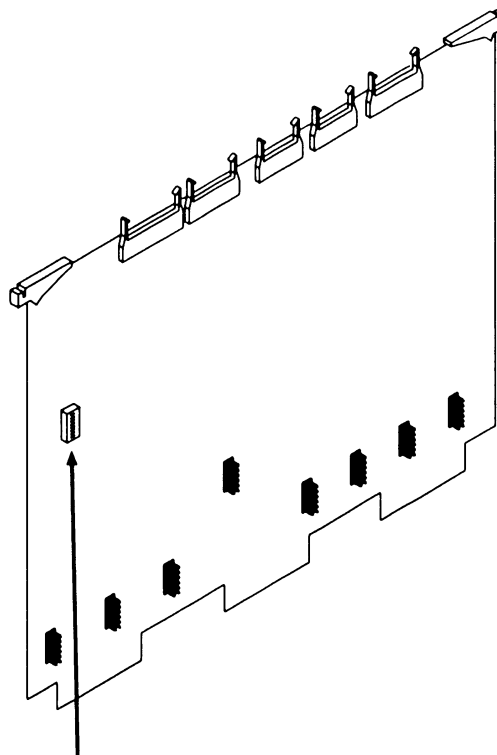

* Switch 7 Enables/
Disables X.21 option
 = X.21 Disabled
 = X.21 Enabled

▨ = Switch Position
 o = Contacts Open
 x = Contacts Closed

➡ NEXT

7.2 Removal Procedures

REPAIR

7.2.11 1-Port TC Controller (25V76-1) Removal (Sheet 3 of 3)

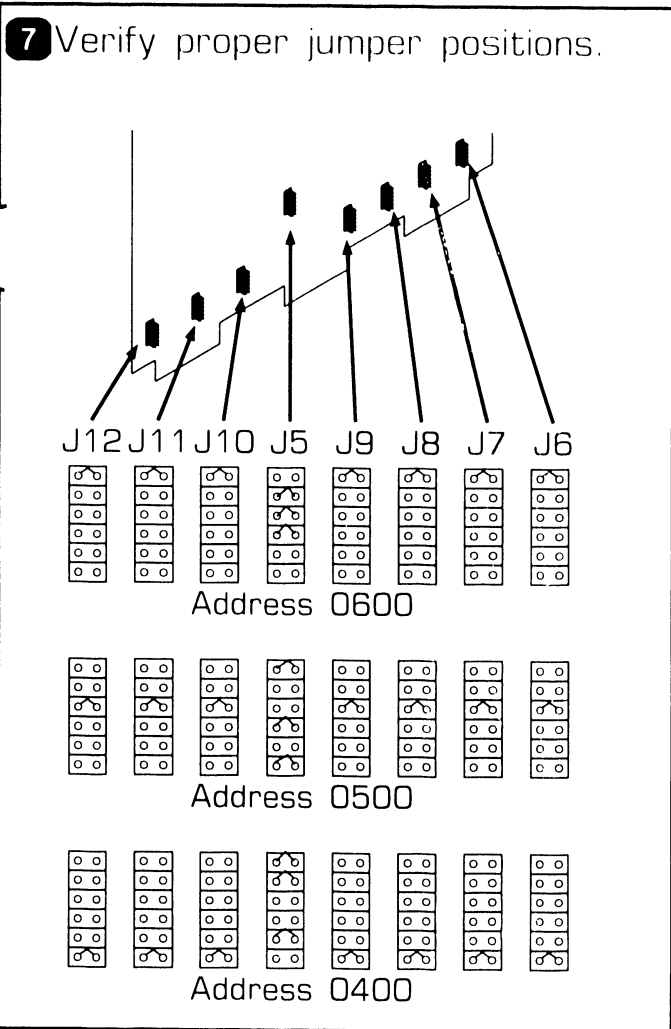
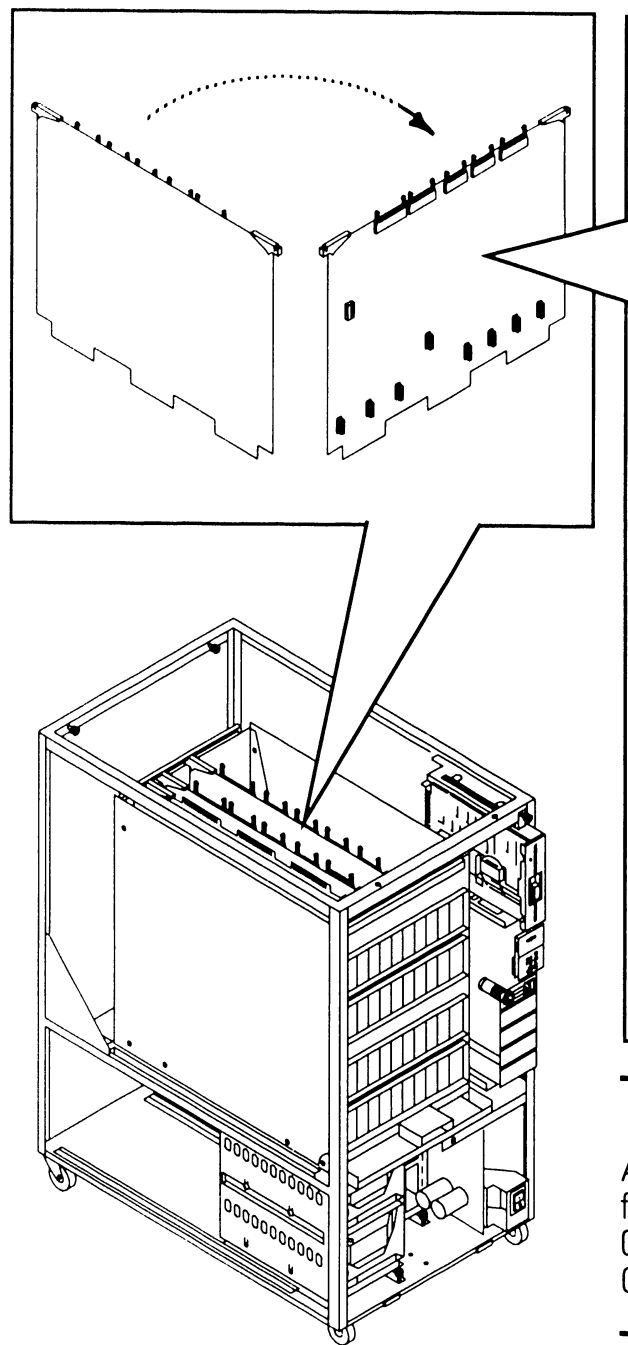

NOTE

Address 0600 is preferred for the first TC Controller. Address 0500 and 0400 are used for additional TC Controllers.

● END

7.2 Removal Procedures

REPAIR

7.2.12 2-Port TC Controller (25V76-2) Removal (Sheet 1 of 3)

- 1 Power-off the VS-75E and disconnect ac power. (➡4.2)
- 2 Remove top cover. (➡7.2.1)
- 3 Remove PCB Holddown device. (➡7.2.4)

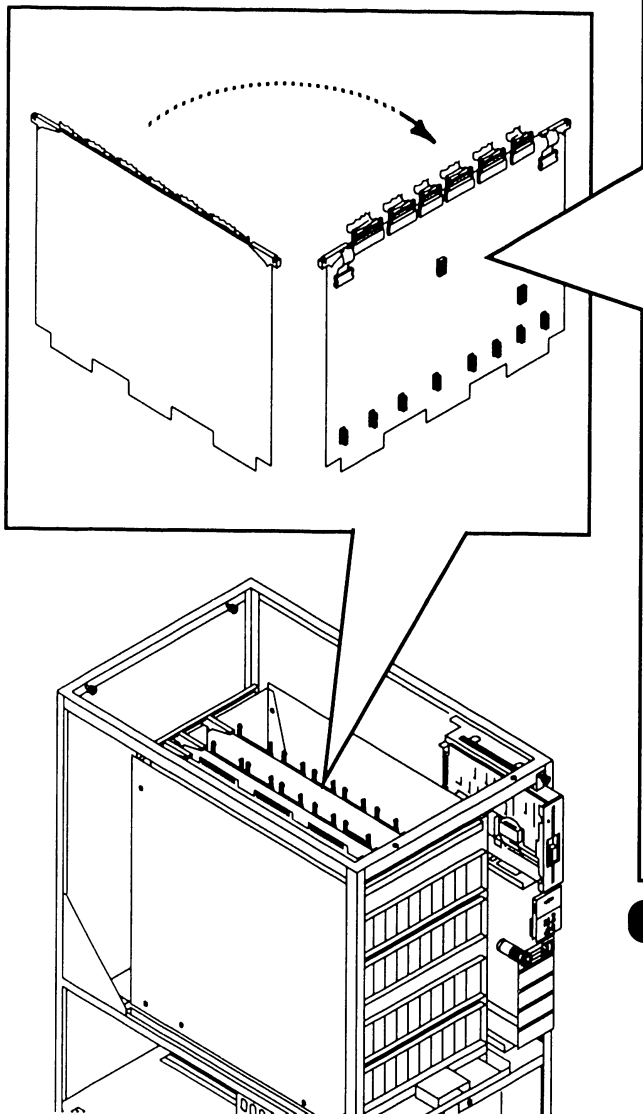

- 4 Note cable stripe (pin 1) and remove the following cables:
 - a) 16-pin Light Panel Connectors S1 and S2.
 - b) RS366 Connector J3A and J3B.
 - c) RS232 Connector J2A and J2B.
 - d) X.21 Connector J13A and J13B.

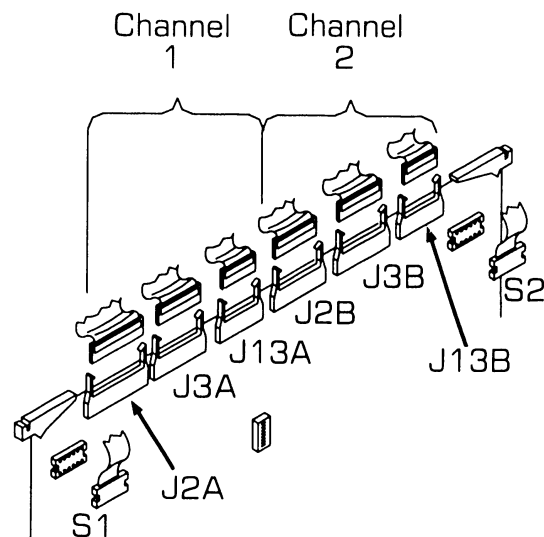

- 5 Remove 2-Port TC board from card cage. (➡7.2.4)

➡NEXT

7.2 Removal Procedures

REPAIR

7.2.12 2-Port TC Controller (25V76-2) Removal (Sheet 2 of 3)

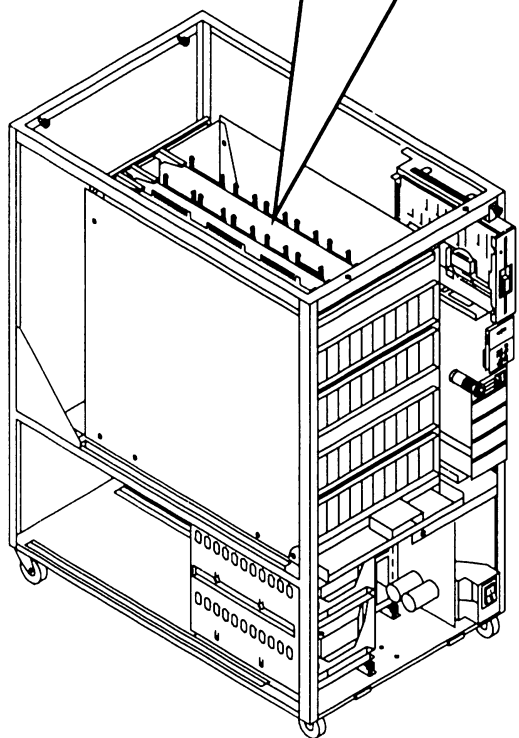
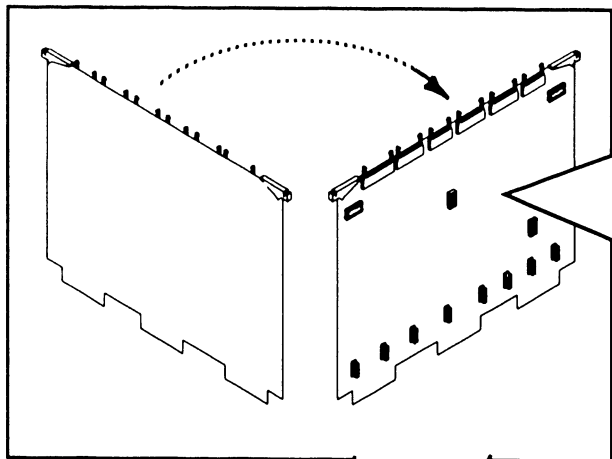

6 Verify proper switch settings for normal channel (1 and 2) operation.

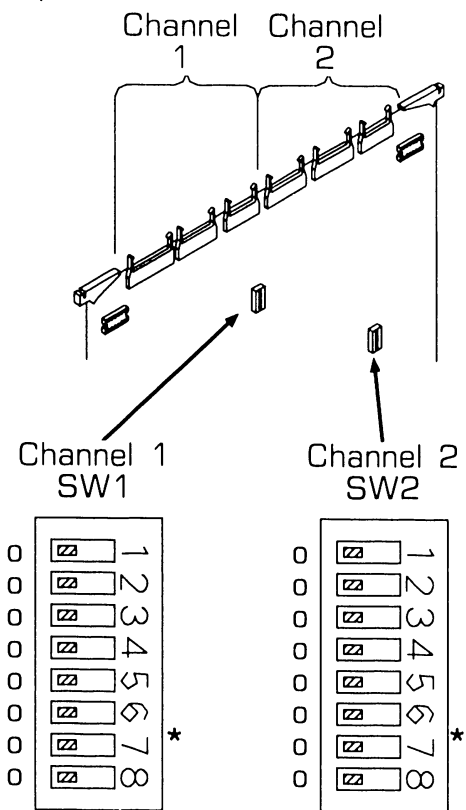

* Switch 7 Enables/Disables X.21 Option

= X.21 Disabled
 = X.21 Enabled

= Switch Position
o = Contacts Open
x = Contacts Closed

➡ NEXT

7.2 Removal Procedures

REPAIR

7.2.12 2-Port TC Controller (25V76-2) Removal (Sheet 3 of 3)

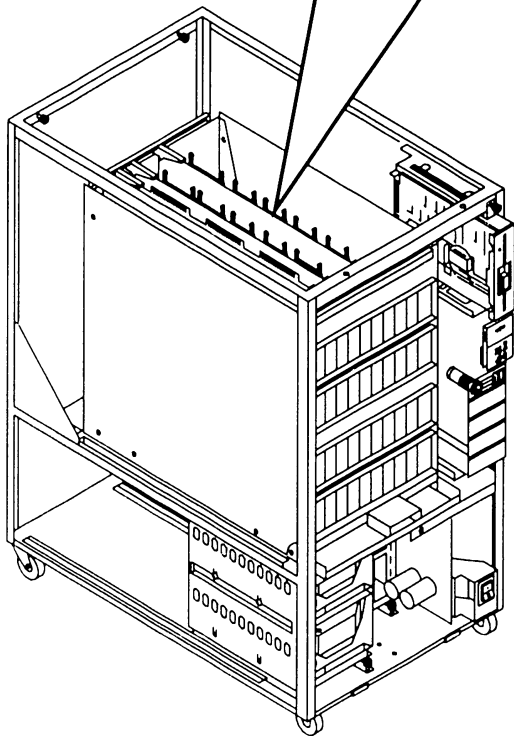
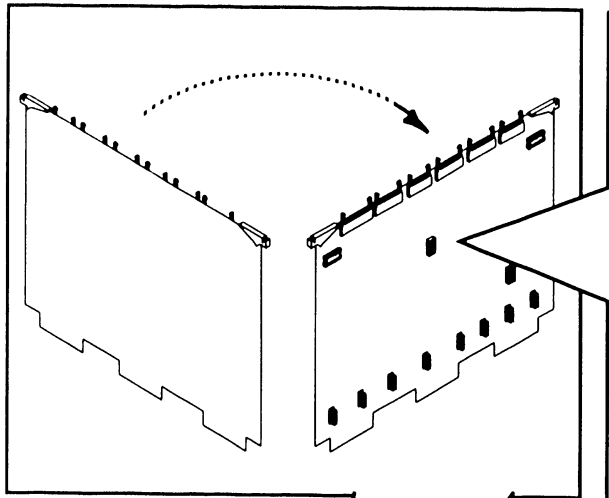

7 Verify proper jumper positions.

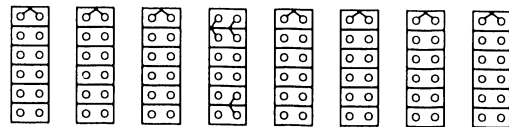
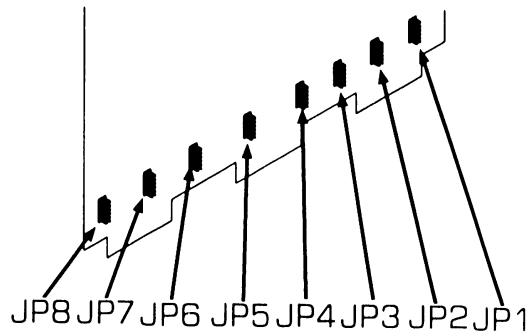

Address 0600

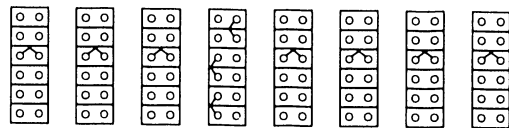

Address 0500

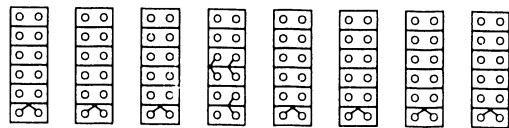

Address 0300

NOTE

Address 0600 is preferred for the first TC Controller. Address 0500 and 0300 are used for additional TC controllers.

● END

7.2 Removal Procedures

REPAIR

7.2.13 UISIO Controller (25V67) Removal (Sheet 1 of 3)

- 1 Power-off the VS-75E and disconnect ac power. (➡4.2)
- 2 Remove top cover. (➡7.2.1)
- 3 Remove PCB Holddown device. (➡7.2.4)

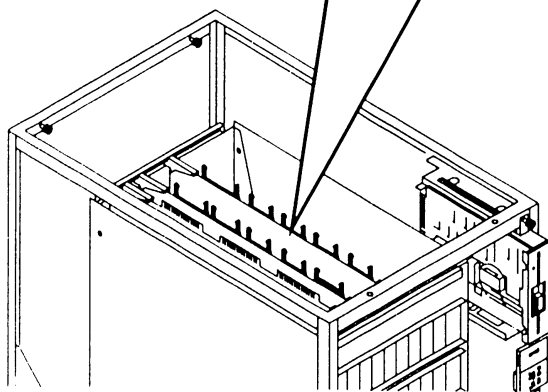
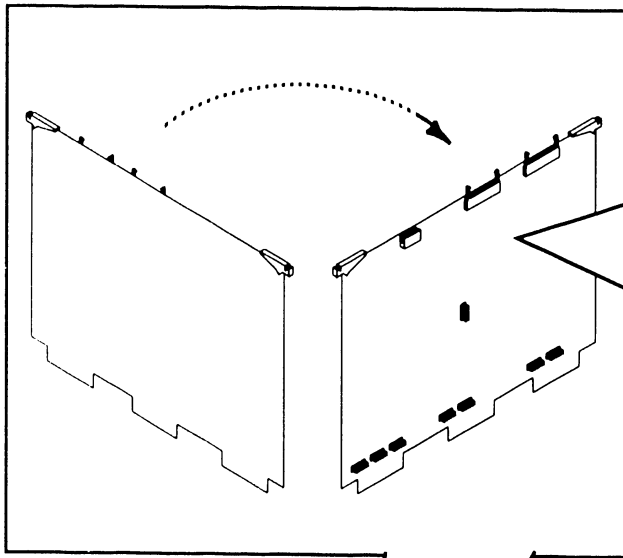

- 4 Note cable stripe (pin 1) and remove the following cable:

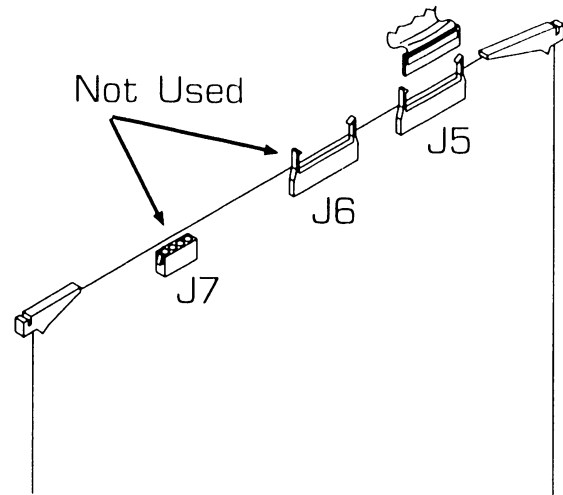

NOTE

The Global Modem MuxBus connector J6 and Global Modem Power connector J7 are not used.

a) 34-pin MuxBus Connector J5.

- 5 Remove UISIO Controller from card cage. (➡7.2.4)

➡NEXT

7.2 Removal Procedures

REPAIR

7.2.13 UISIO Controller (25V67) Removal (Sheet 2 of 3)

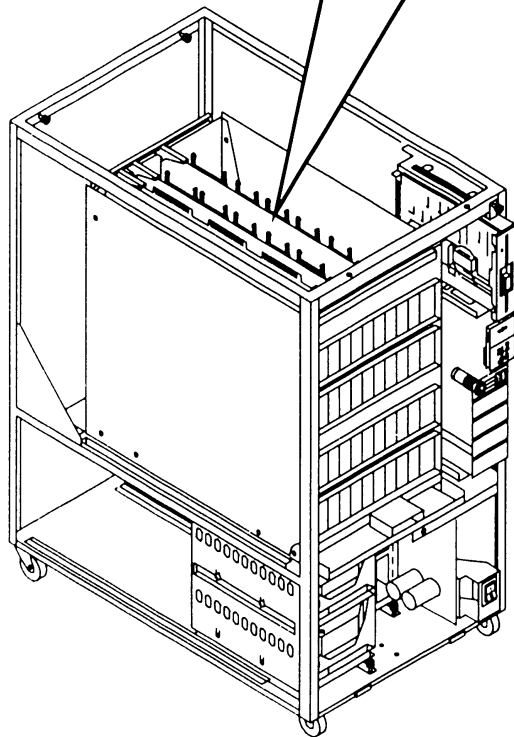
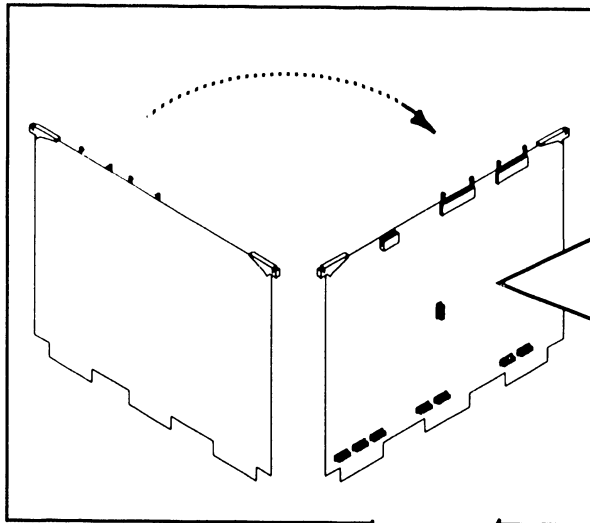

6 Verify proper jumper positions.

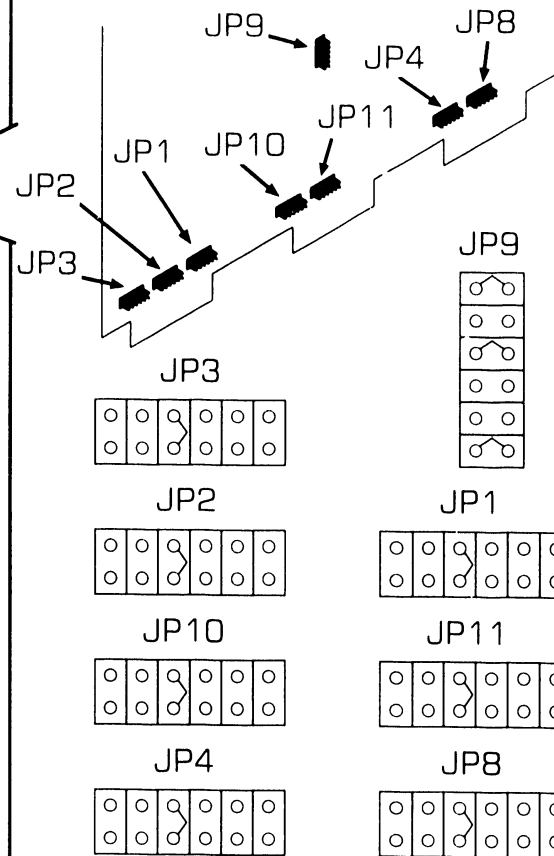

Address 0400

NOTE

Address 0400 is preferred for the UISIO Controller. Address 0500, 0400, or 0300 may be used.

▶NEXT

7.2 Removal Procedures

REPAIR

7.2.13 UISIO Controller (25V67) Removal (Sheet 3 of 3)

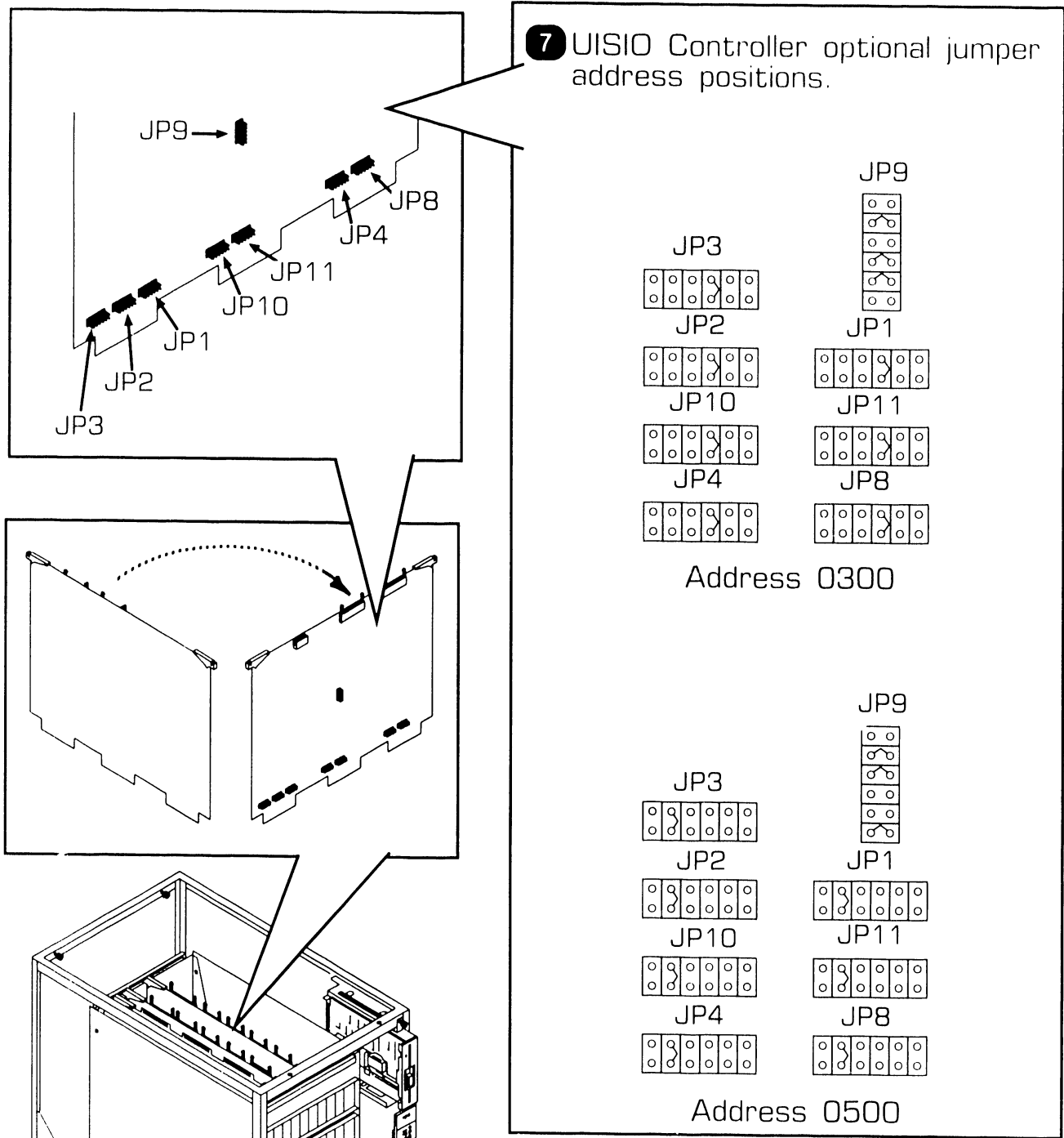

● END

7.2 Removal Procedures

REPAIR

7.2.14 RSF Controller (25V14) Removal (Sheet 1 of 4)

- 1 Power-off the VS-75E and disconnect ac power. (➡4.2)
- 2 Remove top cover. (➡7.2.1)
- 3 Remove PCB Holddown device. (➡7.2.4)

- 4 Note the cable stripe (pin 1) and remove the following cable:

a) 60-pin MuxBus Connector J1.

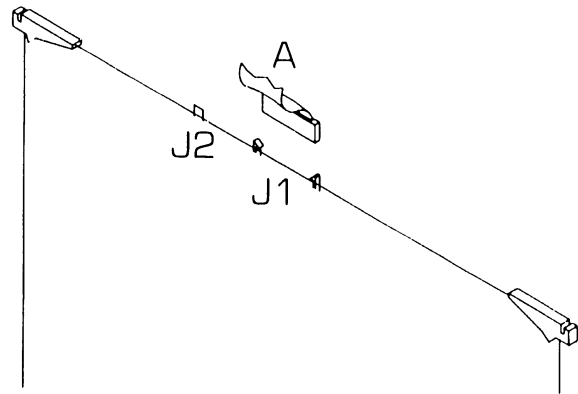

- 5 Remove RSF Controller from card cage. (➡7.2.4)

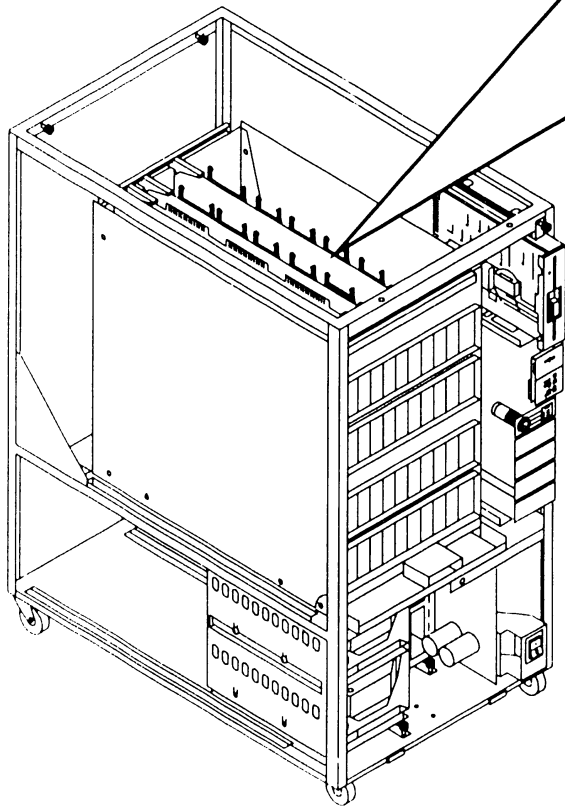

➡NEXT

7.2 Removal Procedures

REPAIR

7.2.14 RSF Controller (25V14) Removal (Sheet 2 of 4)

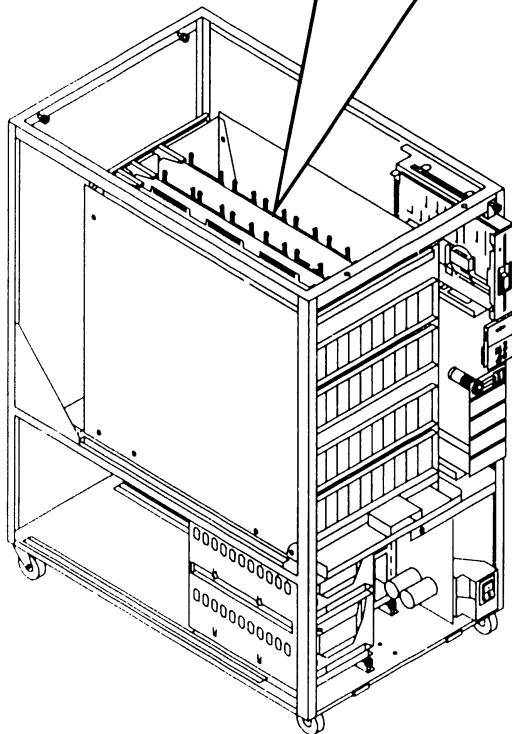
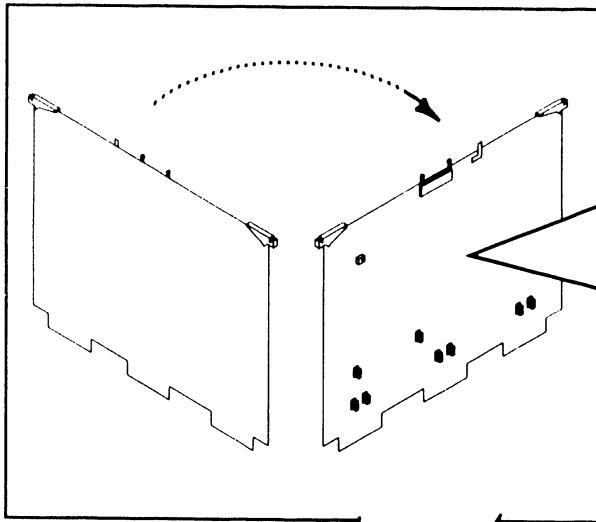

6 Verify proper jumper positions.

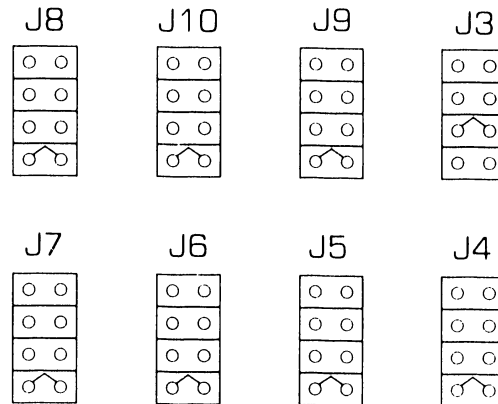
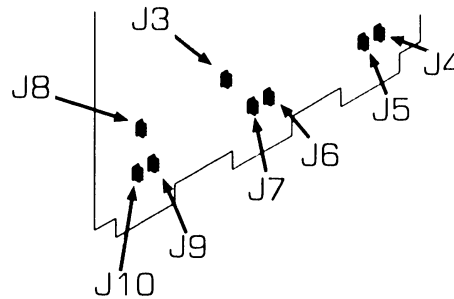

Address 0600

NOTE

Address 0600 is preferred for the RSF Controller. Address 0500, 0400, or 0300 may be used.

➡ NEXT

7.2 Removal Procedures

REPAIR

7.2.14 RSF Controller (25V14) Removal (Sheet 3 of 4)

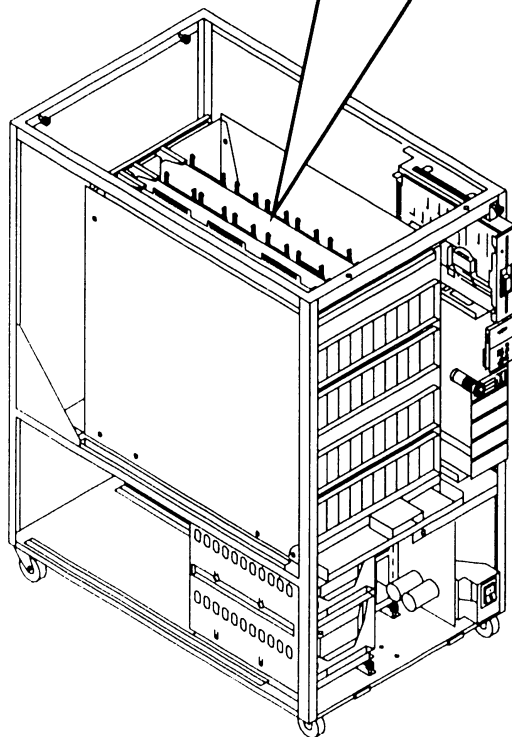
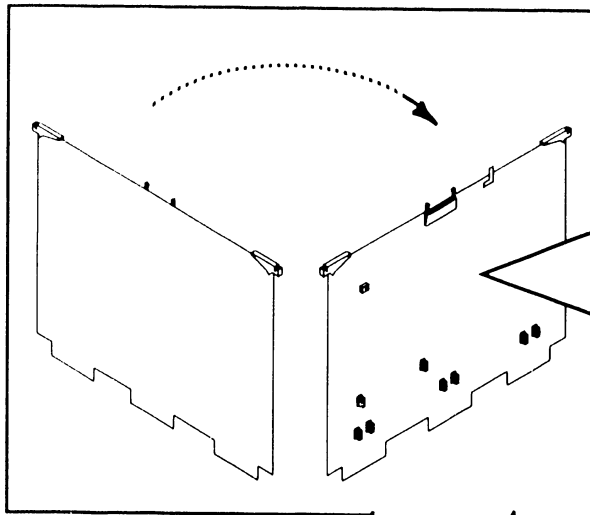

7 RSF Controller optional jumper address positions.

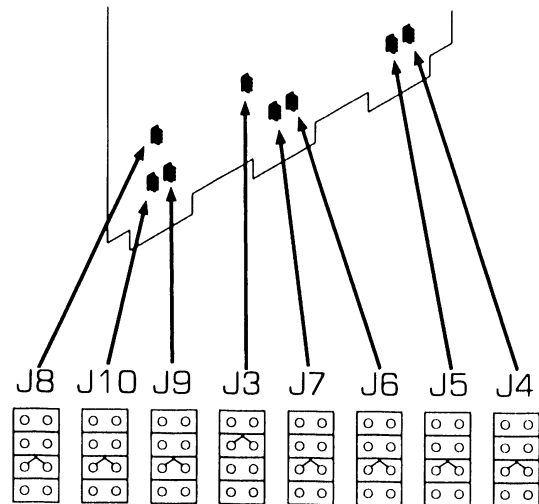

Address 0500

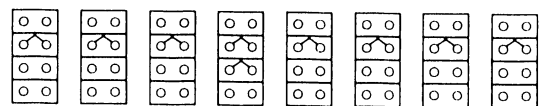

Address 0400

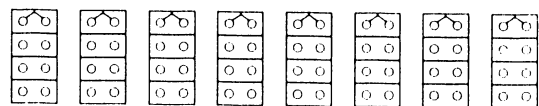

Address 0300

➡ NEXT

7.2 Removal Procedures

REPAIR

7.2.14 RSF Controller (25V14) Removal (Sheet 4 of 4)

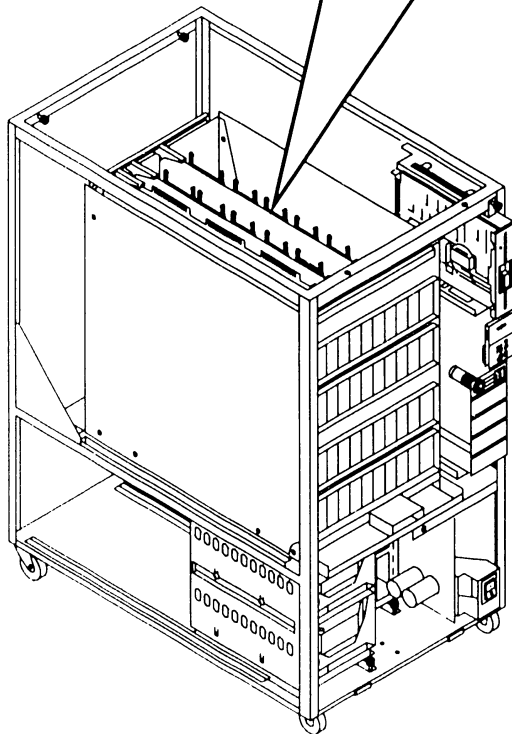
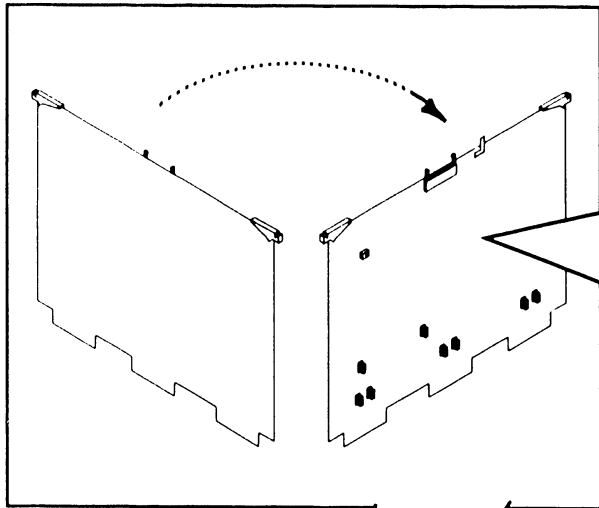

8 Verify proper switch settings.

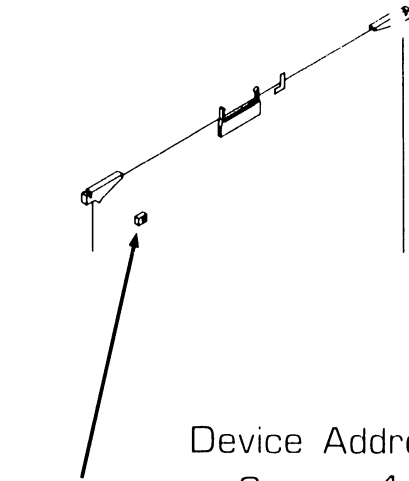

Device Address

0

1

X
 X

X
 0

2

3

0
 X

0
 0

= Switch Position
o = Contacts Open
x = Contacts Closed

NOTE

Device Address 0 is the highest priority device on the RSF bus.

● END

7.2 Removal Procedures

REPAIR

7.2.15 Async Controller (25V36) Removal (Sheet 1 of 3)

- 1 Power-off the VS-75E and disconnect ac power. (➡4.2)
- 2 Remove top cover. (➡7.2.1)
- 3 Remove PCB Holdown device. (➡7.2.4)

- 4 Note cable stripe (pin 1) and remove the following cables:

a) 40-pin Driver Board Connectors J1, J2, J3, and J4.

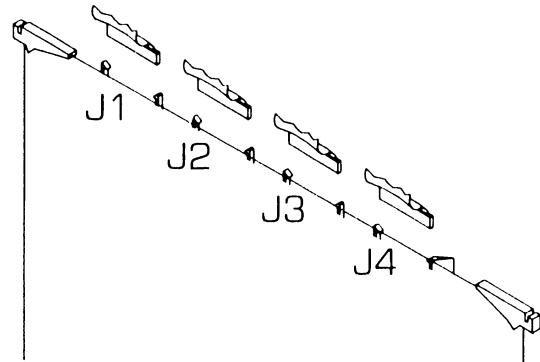

- 5 Remove Async Controller from card cage. (➡7.2.4)

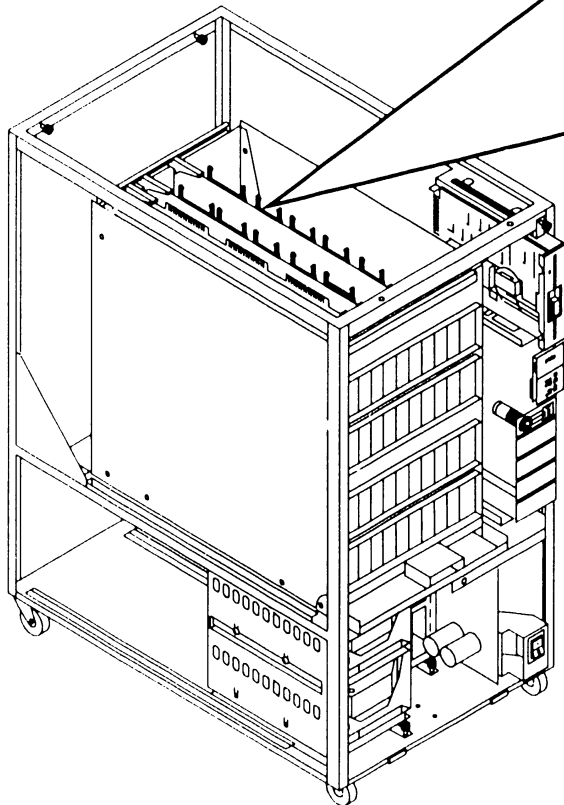

➡NEXT

7.2 Removal Procedures

REPAIR

7.2.15 Async Controller (25V36) Removal (Sheet 2 of 3)

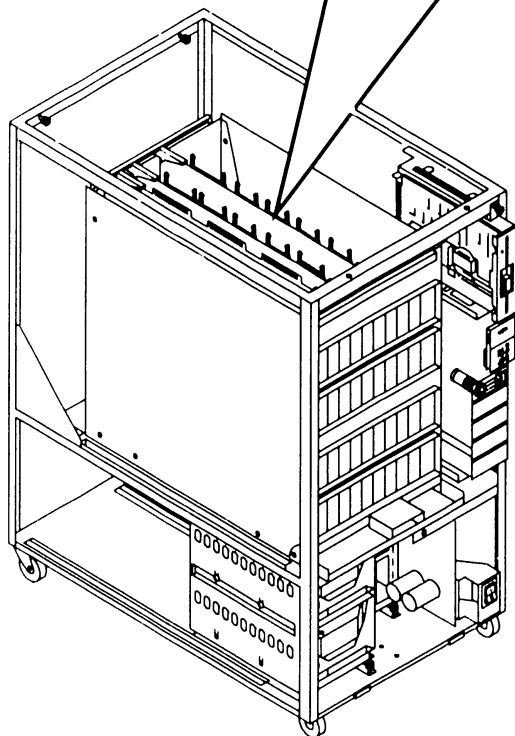
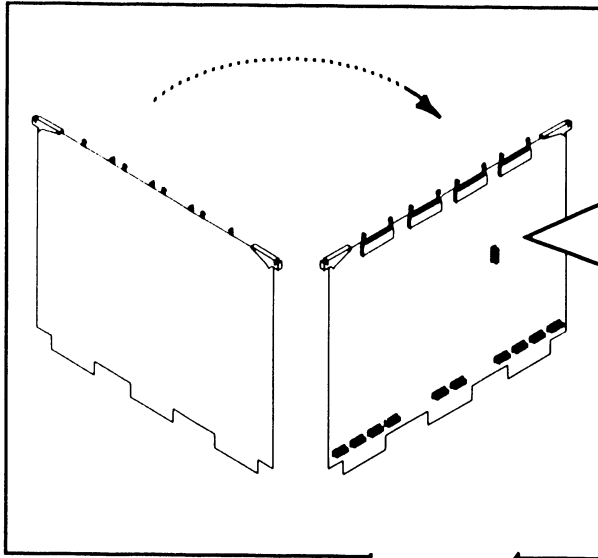

6 Verify proper jumper positions.

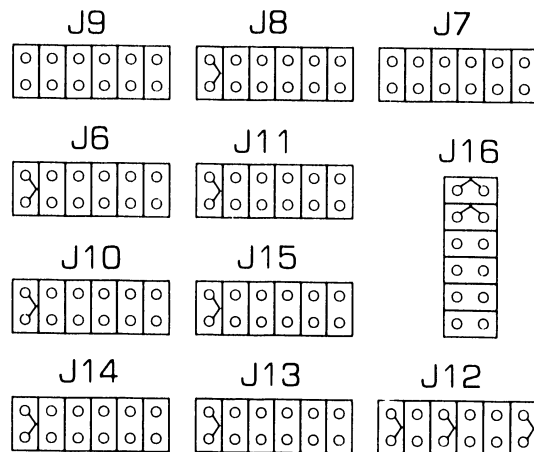
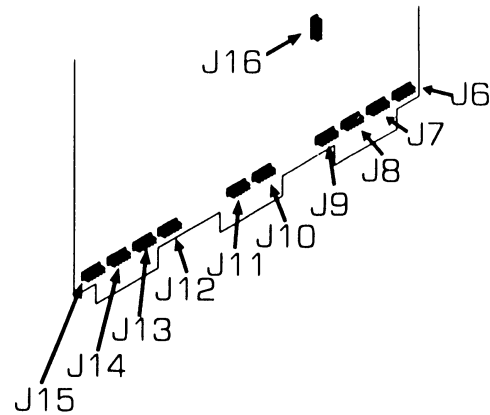

Address 0600

NOTE

Address 0600 is preferred for the Async Controller. Address 0500, 0400, or 0300 may be used.

Jumper headers J7 and J9 have all Jumpers removed.

➡ NEXT

7.2 Removal Procedures

REPAIR

7.2.15 Async Controller (25V36) Removal (Sheet 3 of 3)

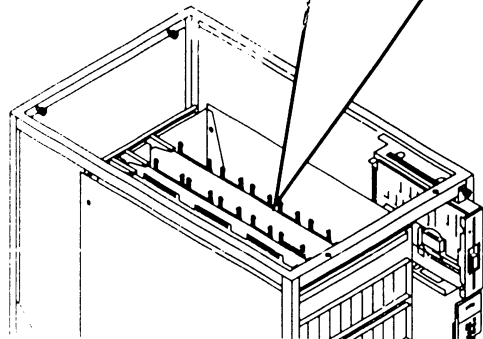
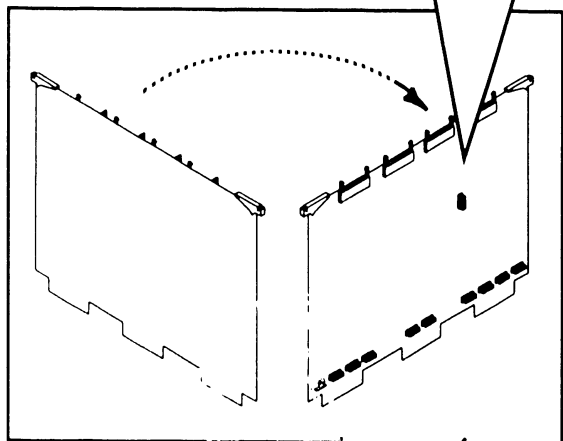
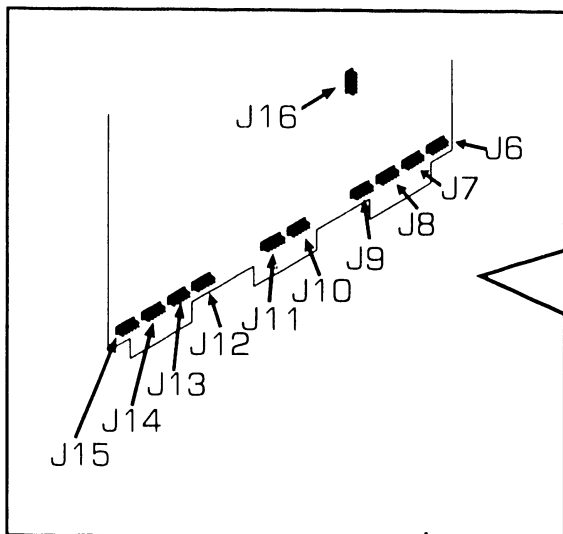

7 Optional jumper address positions for Async Controller.

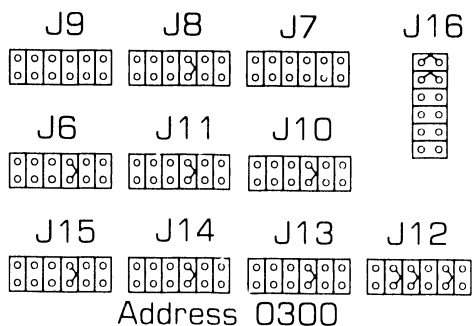
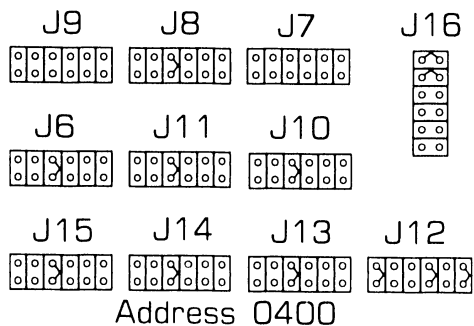
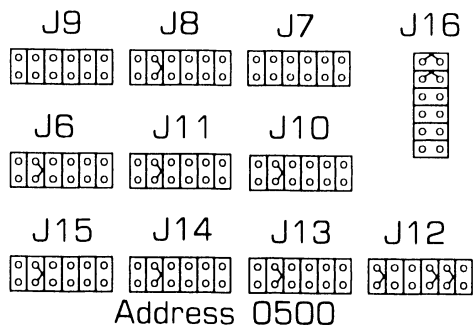

● END

7.2 Removal Procedures

REPAIR

7.2.16 Power Supply Removal (Sheet 1 of 4)

WARNING

DO NOT OPEN SWITCHING POWER SUPPLY UNDER ANY CIRCUMSTANCE. EXTREMELY DANGEROUS VOLTAGE AND CURRENT LEVELS, IN EXCESS OF 300 VOLTS DC AND UNLIMITED CURRENT, ARE PRESENT WITHIN POWER SUPPLY. DO NOT ATTEMPT TO REPAIR POWER SUPPLY; IT IS FIELD REPLACEABLE ONLY.

- 1 Power-off the VS-75E and disconnect ac power. (▶4.2)
- 2 Remove top cover. (▶7.2.1)
- 3 Remove front cover (▶7.2.2) and side covers. (▶7.2.3)

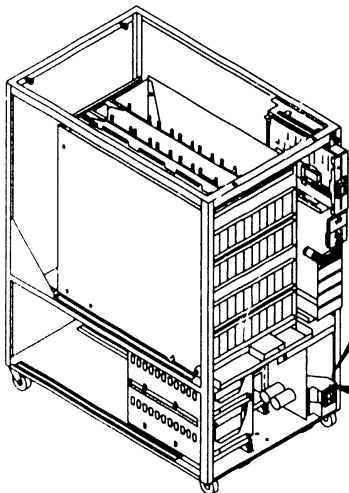

- 4 Remove quick-disconnect chassis ground lug.

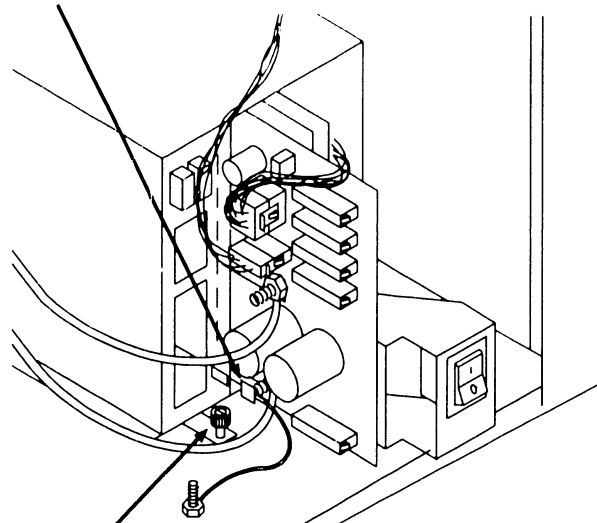

- 5 Loosen knurled screw securing power supply to chassis.

- 6 Slide power supply out about 3 inches.

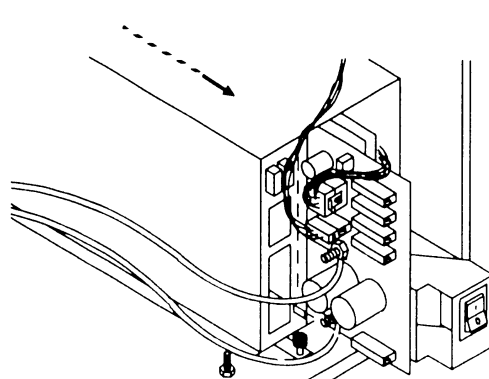

▶NEXT

7.2 Removal Procedures

REPAIR

7.2.16 Power Supply Removal (Sheet 2 of 4)

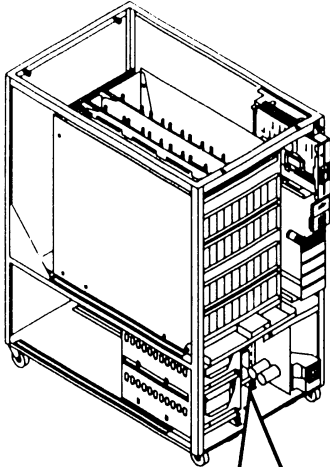

- 7** Remove nuts securing +5V Buss and +/-0V Buss leads to power supply and remove leads.

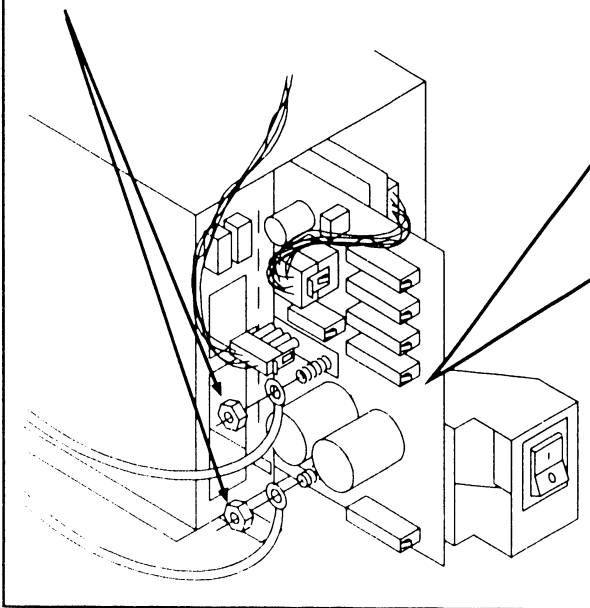

NOTE

Do Not remove cable from PDU connector J9. This cable is replaced with the power supply.

- 8** Remove DC Fan assembly cable from PDU connector J12.

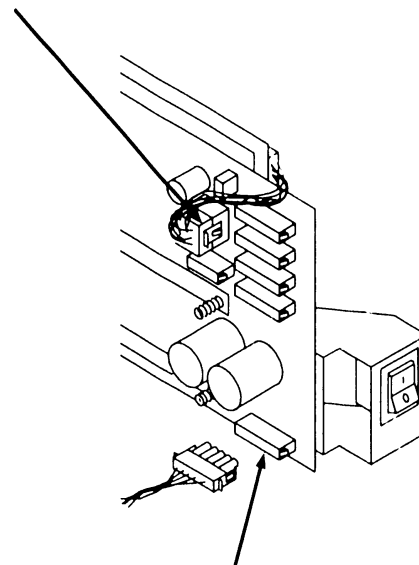

- 9** Remove all optional rear panel assemblies power cables (if any) from PDU connectors J1, J7, J8, J11, and J13.

▶ NEXT

7.2 Removal Procedures

REPAIR

7.2.16 Power Supply Removal (Sheet 3 of 4)

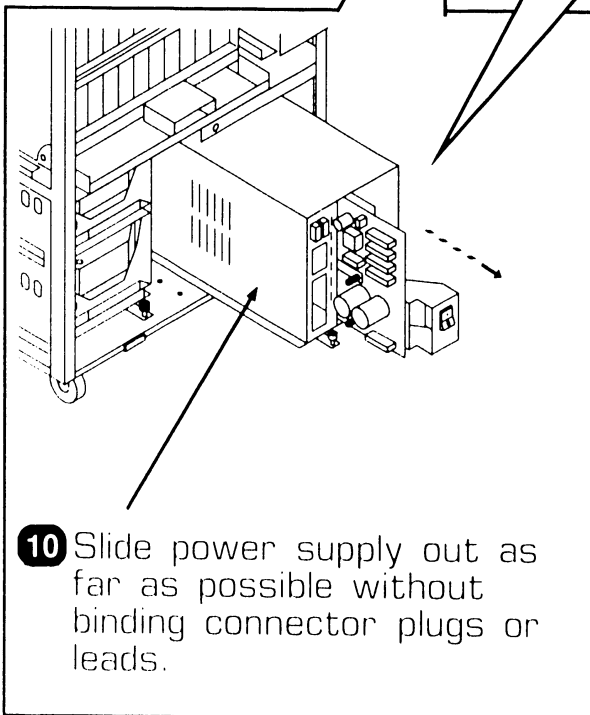
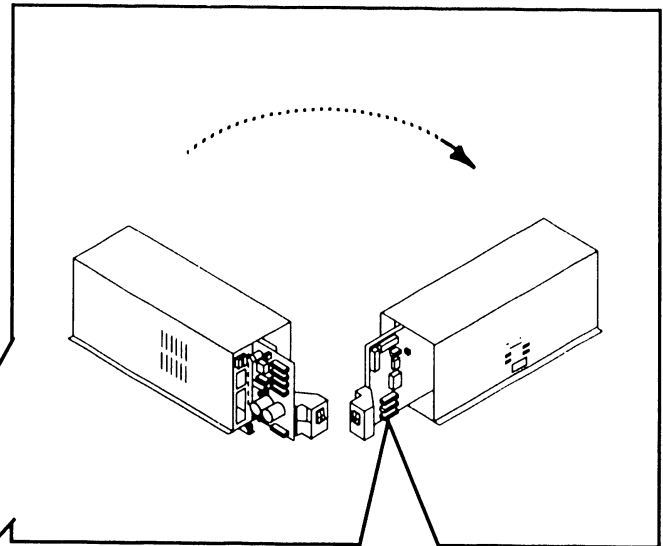
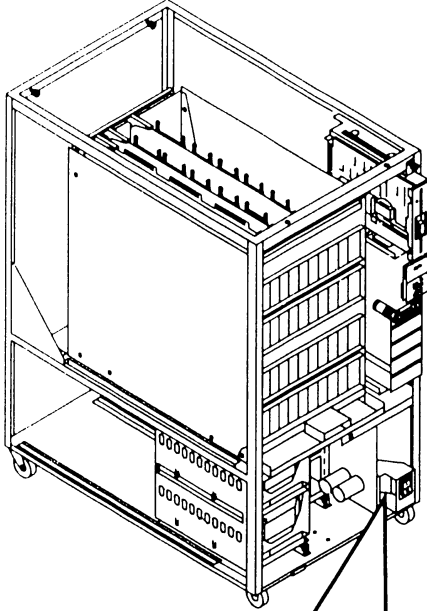

10 Slide power supply out as far as possible without binding connector plugs or leads.

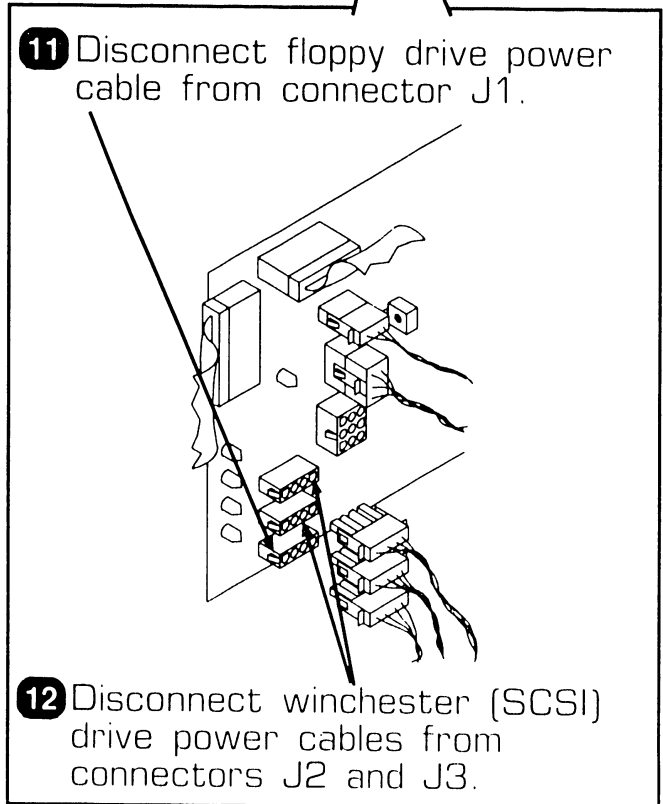

11 Disconnect floppy drive power cable from connector J1.

12 Disconnect winchester (SCSI) drive power cables from connectors J2 and J3.

➡ NEXT

7.2 Removal Procedures

7.2.16 Power Supply Removal (Sheet 4 of 4)

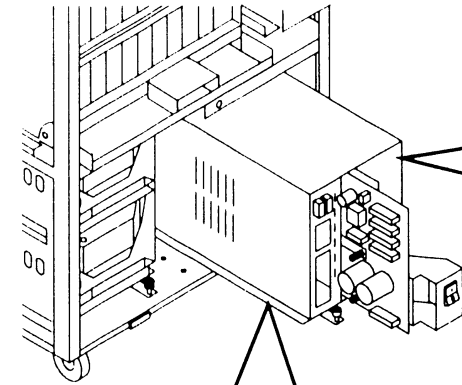

15 Remove power supply from chassis.

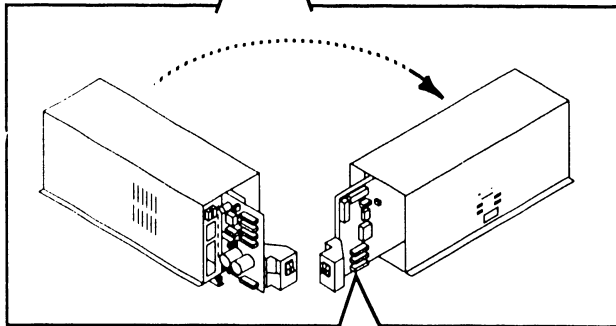
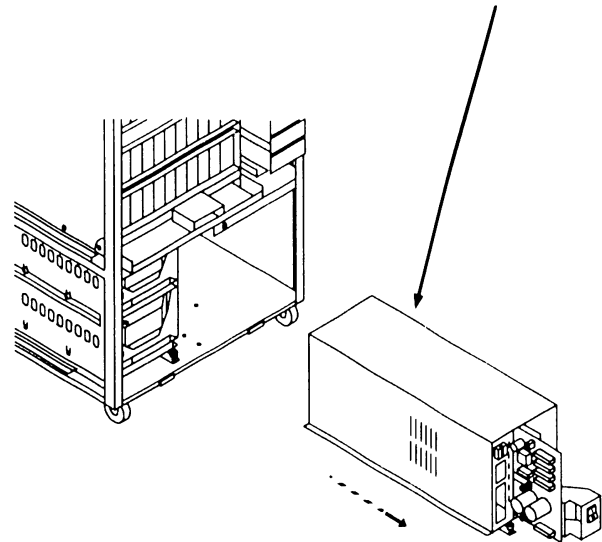

13 Disconnect EAPA power cable from connector J7.

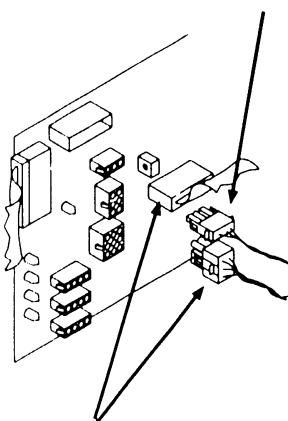

14 Disconnect Motherboard power/signal cables from connectors J5 and J8.

NOTE

Before replacing power supply, verify power supply line voltage select is set to match incoming power source. (►3.3.1)

● END

7.2 Removal Procedures

REPAIR

7.2.17 Winchester Drive Removal (Sheet 1 of 6)

- 1 Power-off the VS-75E and disconnect ac power. (▶4.2)
- 2 Remove top cover. (▶7.2.1)
- 3 Remove front cover (▶7.2.2) and side covers. (▶7.2.3)

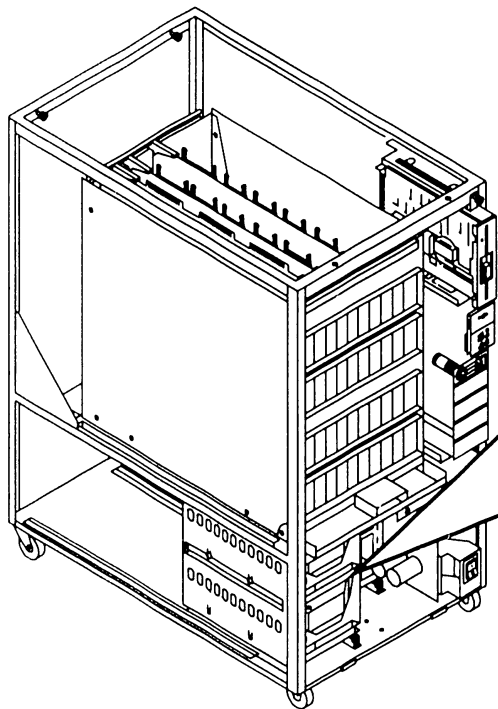

4 Remove SCSI Control cable from drive 0 and drive 1.

5 Remove drive 0 power cable.

6 Remove drive 1 power cable.

A detailed inset diagram showing two drive bays, drive 0 and drive 1. An arrow points to the SCSI control cable connected to both drives. Two other arrows point to the power cables for drive 0 and drive 1, respectively.

▶NEXT

7.2 Removal Procedures

7.2.17 Winchester Drive Removal (Sheet 2 of 6)

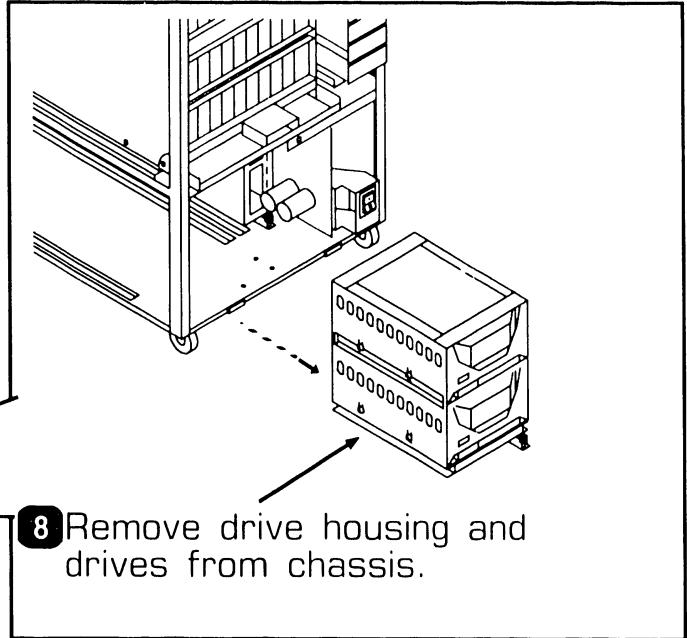
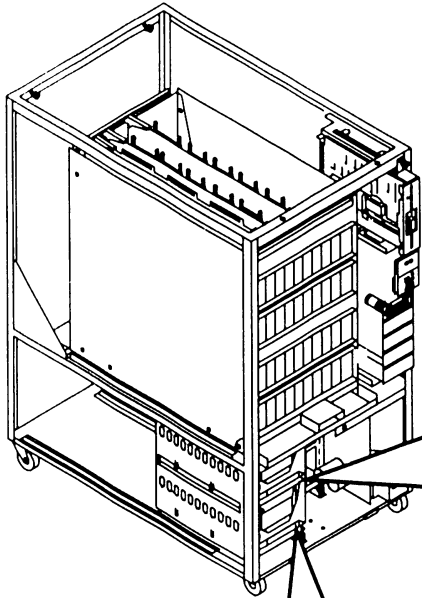

8 Remove drive housing and drives from chassis.

7 Loosen knurled screw securing winchester drive housing to chassis.

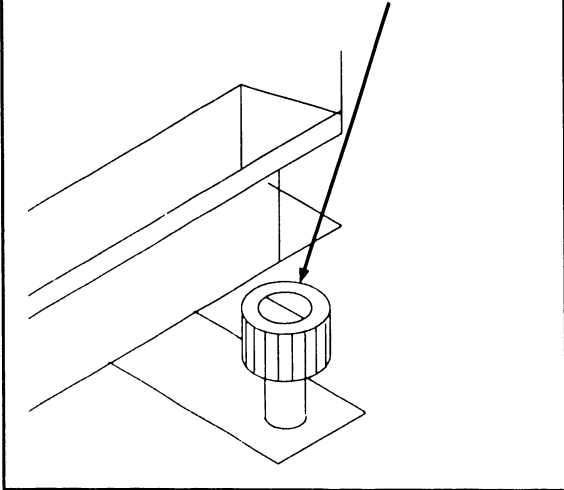

▶ NEXT

7.2 Removal Procedures

REPAIR

7.2.17 Winchester Drive Removal (Sheet 3 of 6)

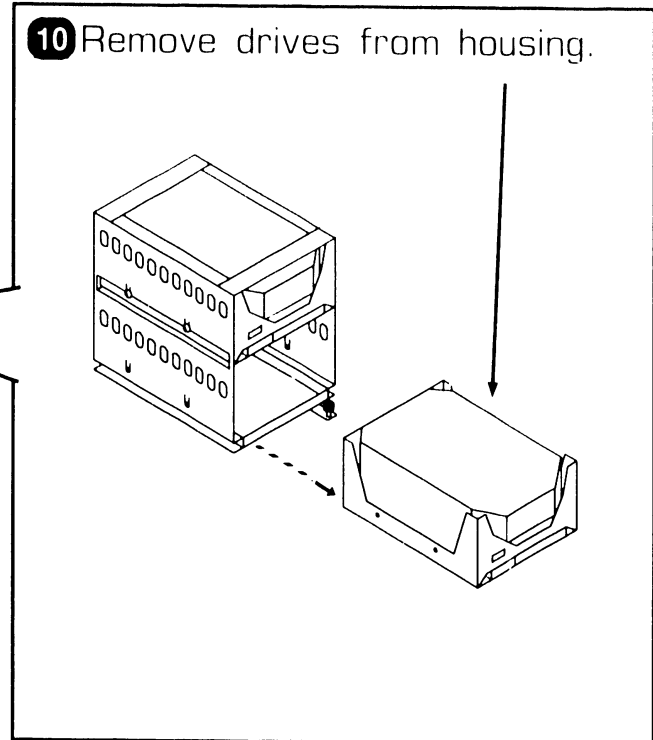
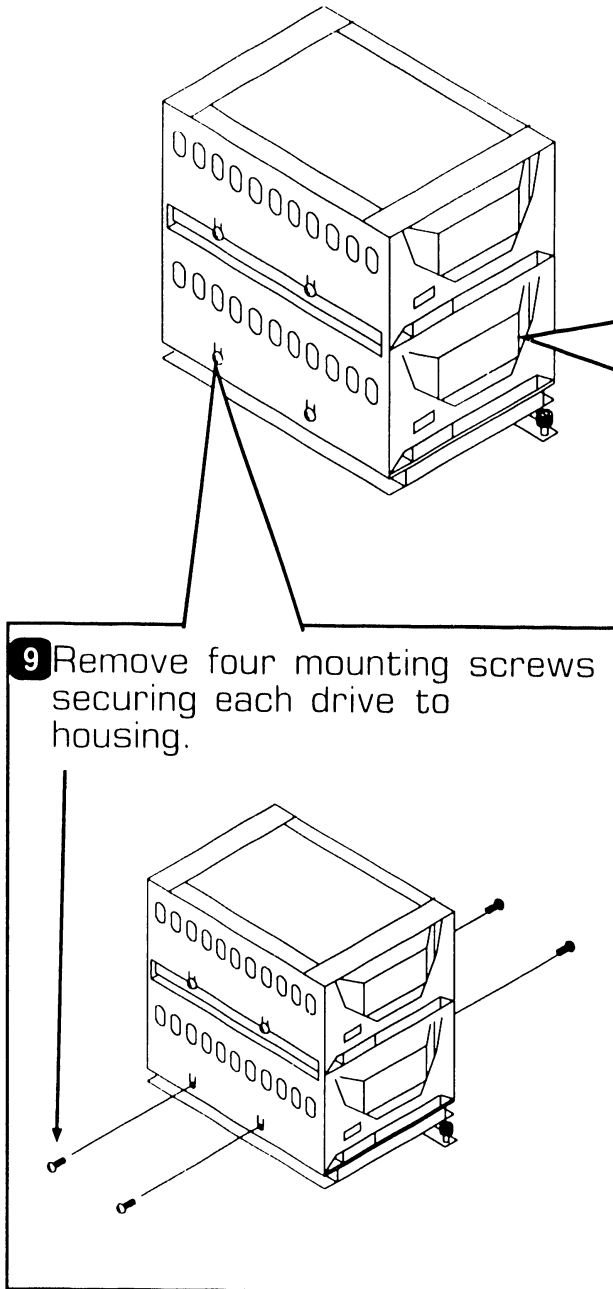

▶ NEXT

7.2 Removal Procedures

REPAIR

7.2.17 Winchester Drive Removal (Sheet 4 of 6)

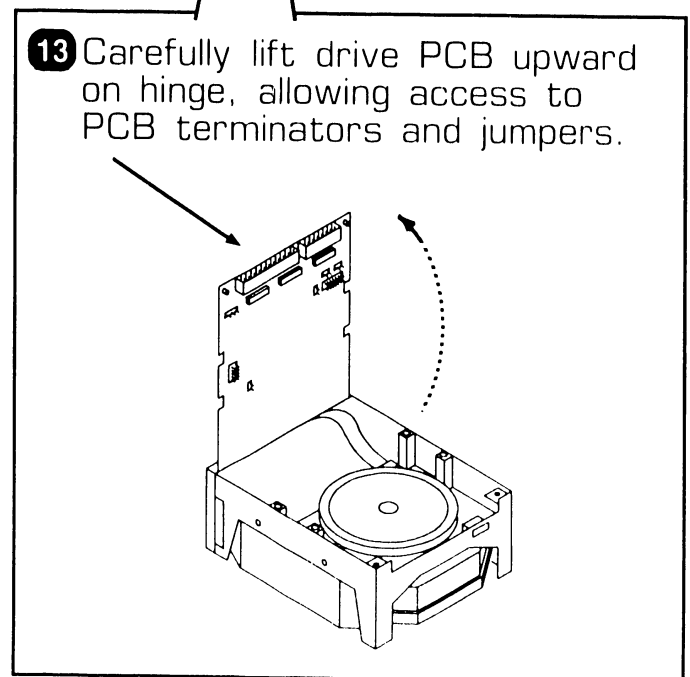
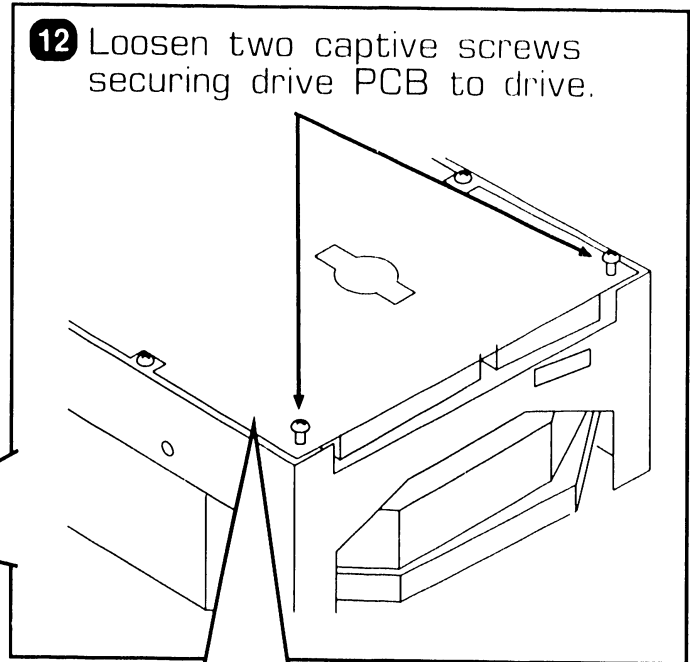
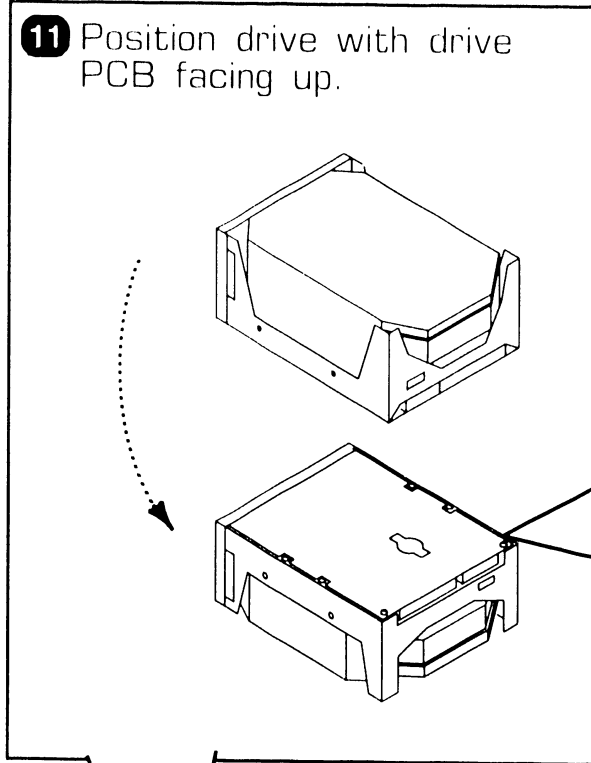

➡ NEXT

7.2 Removal Procedures

REPAIR

7.2.17 Winchester Drive Removal (Sheet 5 of 6)

- 14** Verify drive PCB terminators are removed from locations RN1, RN7, and RN8.

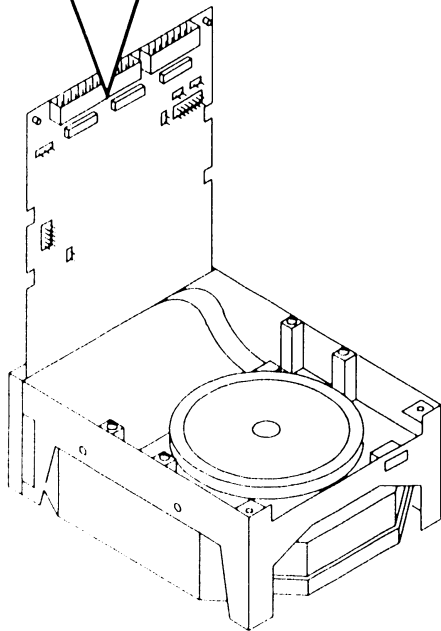
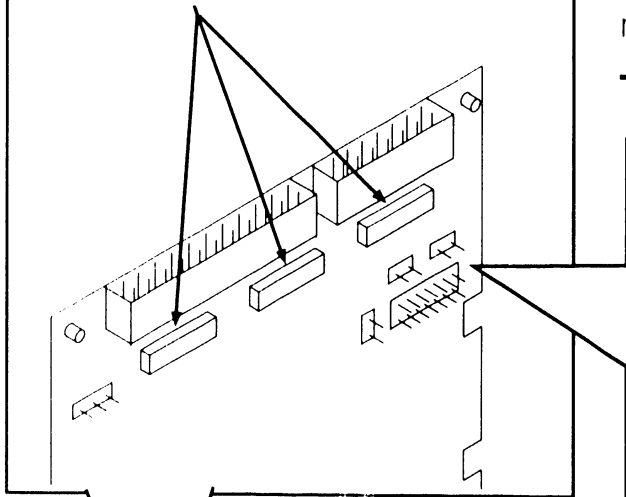

NOTE

Jumper Headers W9, W10, W11, W12, W13, W15, and W16 have jumpers removed.

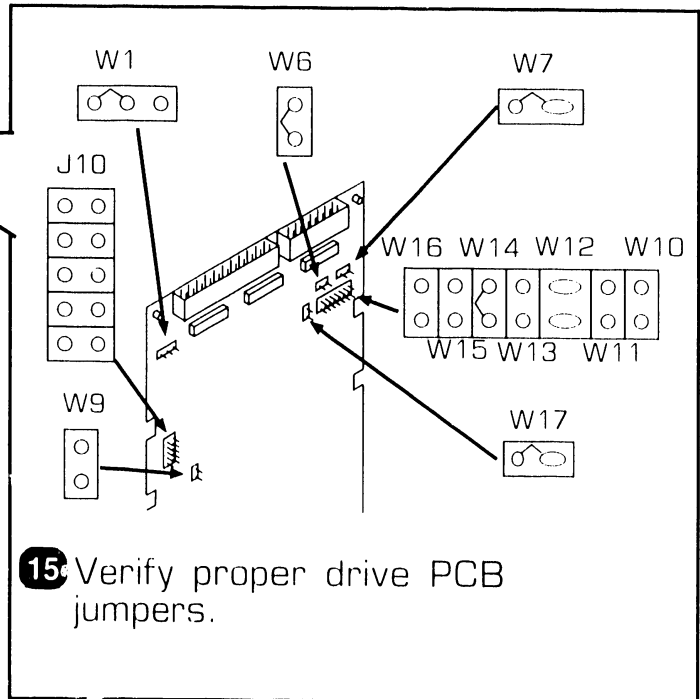

- 15** Verify proper drive PCB jumpers.

- 16** Secure drive PCB to drive.
(▶ 7.2.17-4 reverse steps 12 & 13)

▶ NEXT

7.2 Removal Procedures

REPAIR

7.2.17 Winchester Drive Removal (Sheet 6 of 6)

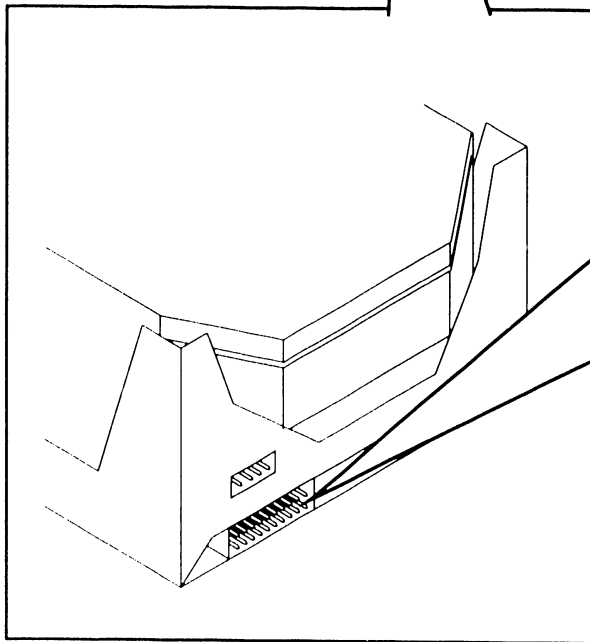
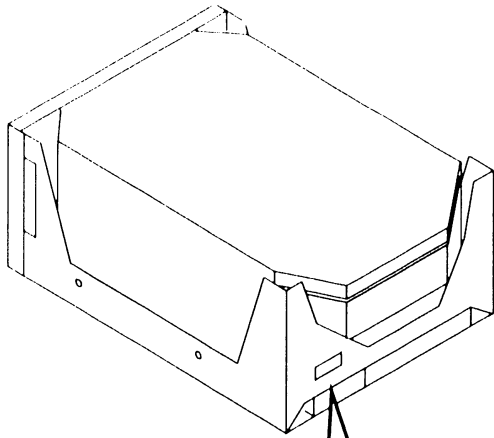

17 Verify connector J2 drive ID address.

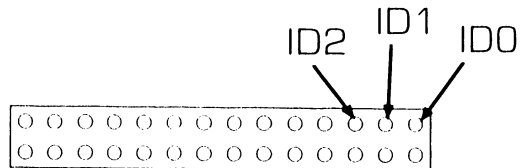

ID Address 6 { } { } { }

ID Address 5 { } { } { }

ID Address 4 { } { } { }

ID Address 3 { } { } { }

NOTE

The SCSI drive that contains IPL Boot files must be assigned ID address 6. Additional SCSI drives ID address can be either ID 5, 4, or 3.

● END

7.2 Removal Procedures

REPAIR

7.2.18 Floppy Drive Removal (Sheet 1 of 3)

- 1 Power-off the VS-75E and disconnect ac power. (▶4.2)
- 2 Remove top cover. (▶7.2.1)
- 3 Remove front cover (▶7.2.2) and side covers. (▶7.2.3)

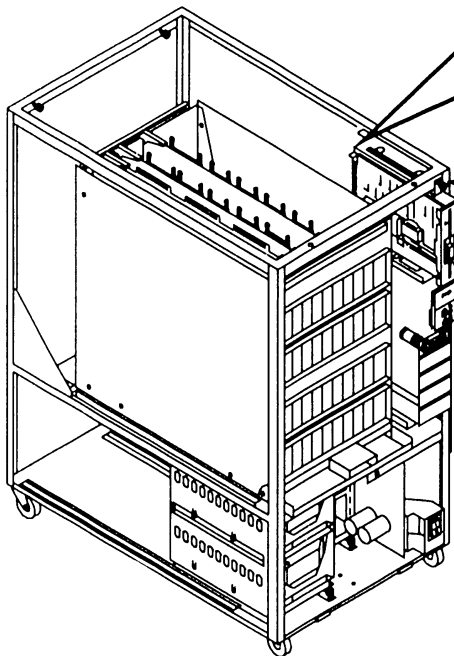

- 4 Remove floppy signal cable from drive connector J1.

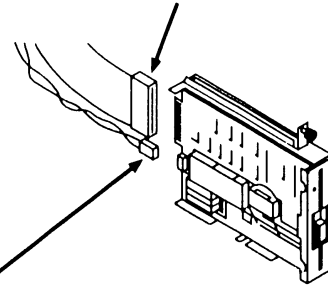

- 5 Remove floppy power cable from drive connector J2.

- 6 Loosen knurled screw securing floppy drive assembly to chassis.

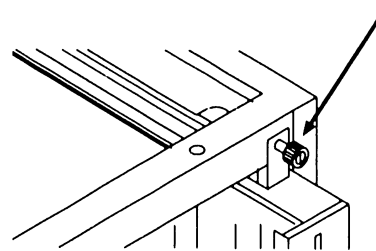

- 7 Remove floppy drive assembly from chassis.

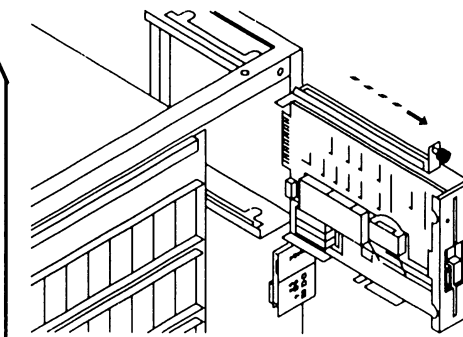

▶NEXT

7.2 Removal Procedures

REPAIR

7.2.18 Floppy Drive Removal (Sheet 2 of 3)

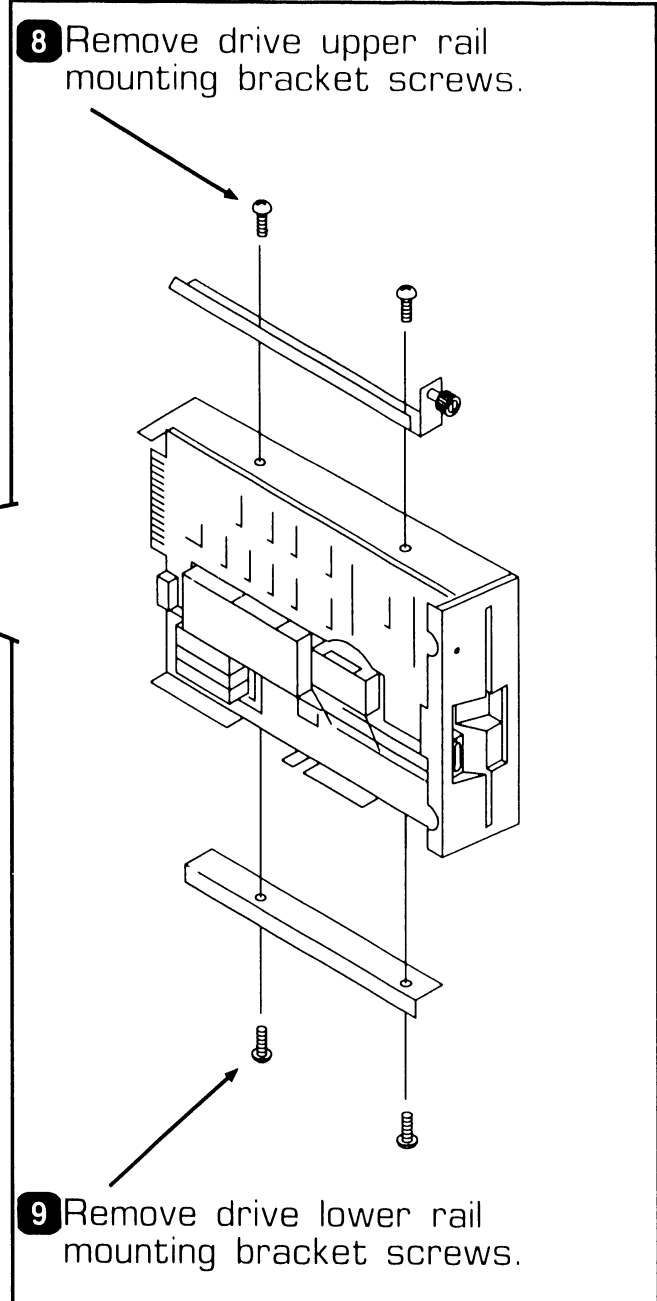
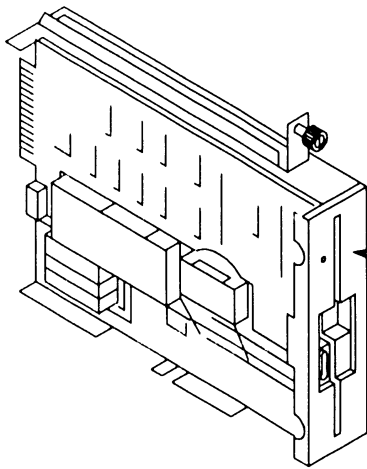

➡ NEXT

7.2 Removal Procedures

REPAIR

7.2.18 Floppy Drive Removal (Sheet 3 of 3)

10 Verify drive PCB terminator is installed in location RP1.

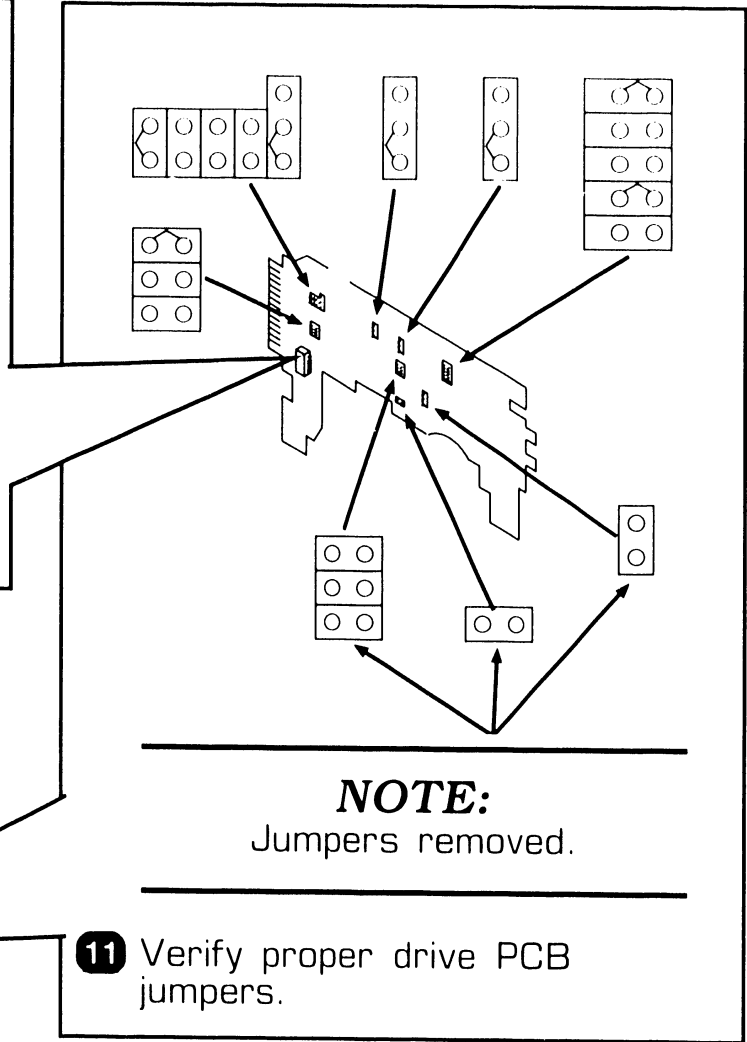
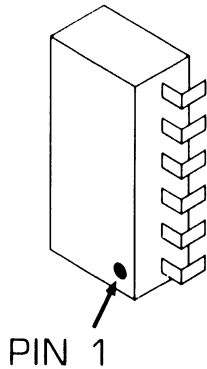

NOTE:

Jumpers removed.

11 Verify proper drive PCB jumpers.

● END

7.2 Removal Procedures

REPAIR

7.2.19 Keylock Assembly Removal

NOTE

Keylock Assembly (keylock/boot device switch) is replaced as an assembly.

- 1 Power-off the VS-75E and disconnect ac power. (▶4.2)
- 2 Remove top cover. (▶7.2.1)
- 3 Remove front cover (▶7.2.2) and side covers. (▶7.2.3)

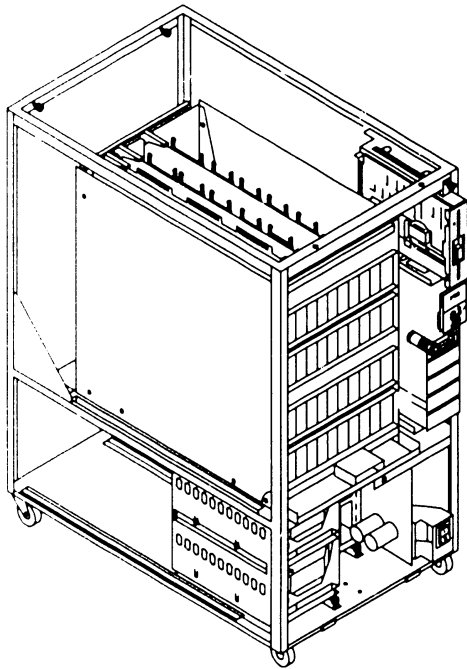

- 4 Remove Keylock Assembly cable connector from Front Panel board.

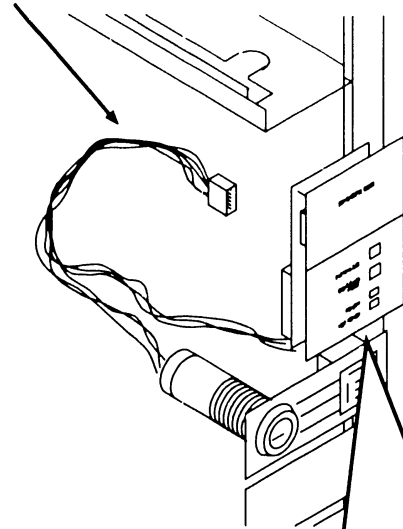

- 5 Remove two screws securing Keylock Assembly to chassis.

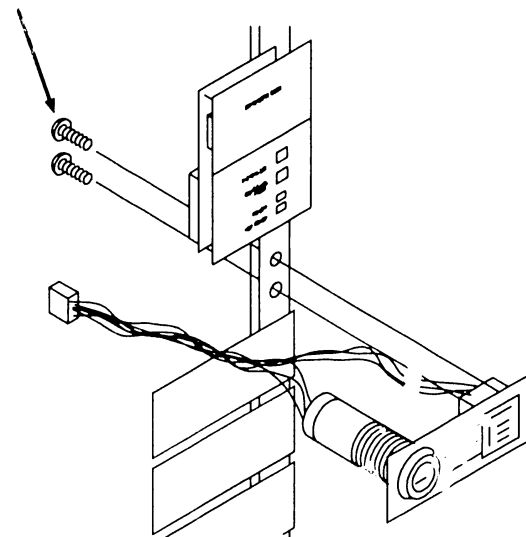

● END

7.2 Removal Procedures

REPAIR

7.2.20 Front Panel Removal

- 1 Power-off the VS-75E and disconnect ac power. (➡4.2)
- 2 Remove top cover. (➡7.2.1)
- 3 Remove front cover (➡7.2.2) and side covers. (➡7.2.3)
- 4 Remove Keylock cable connector from front panel PCB. (➡7.2.19)

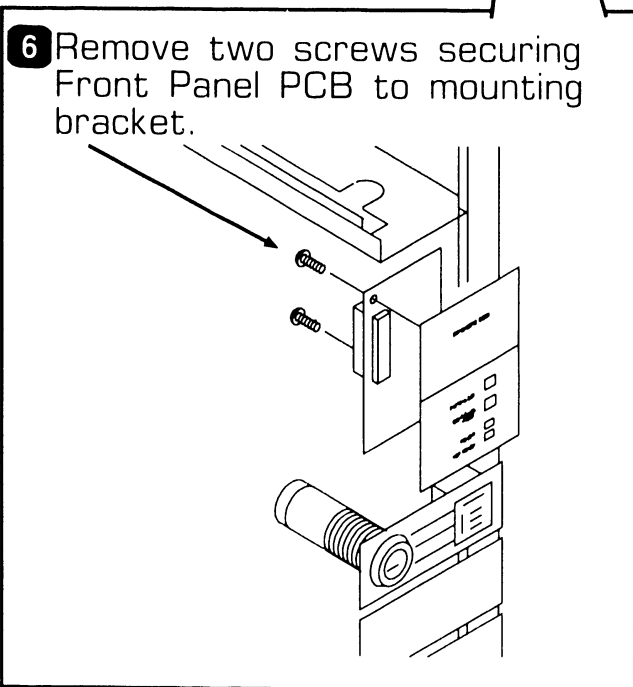
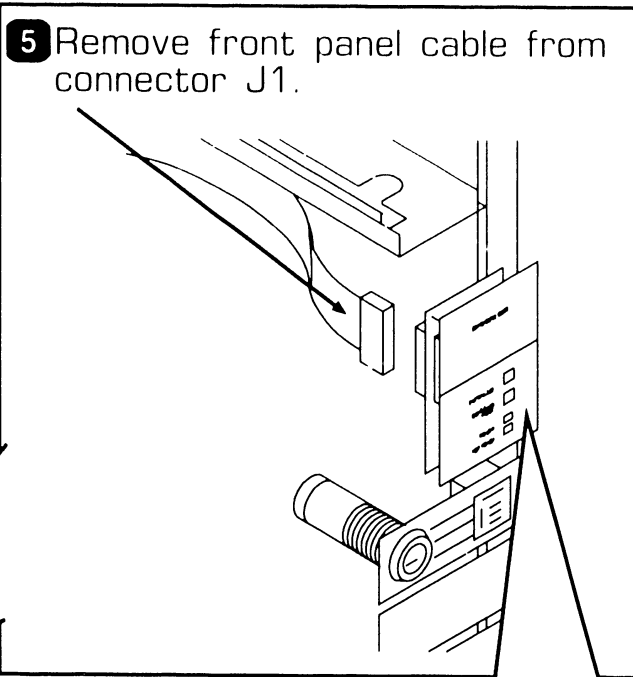
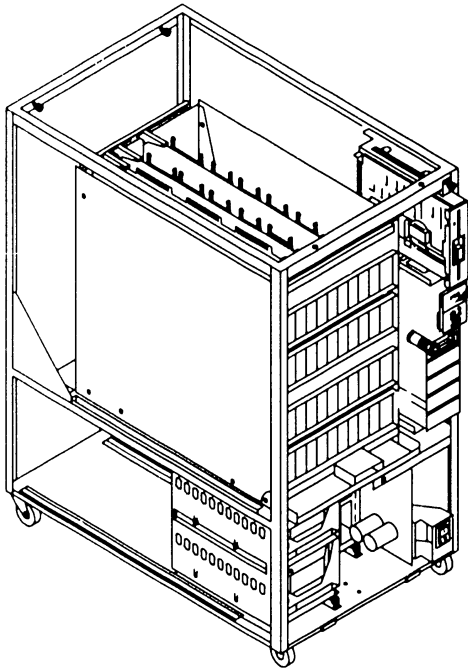

● END

7.2 Removal Procedures

REPAIR

7.2.21 TC Light Panel Removal

- 1 Power-off the VS-75E and disconnect ac power. (▶4.2)
- 2 Remove top cover. (▶7.2.1)
- 3 Remove front cover (▶7.2.2) and side covers. (▶7.2.3)

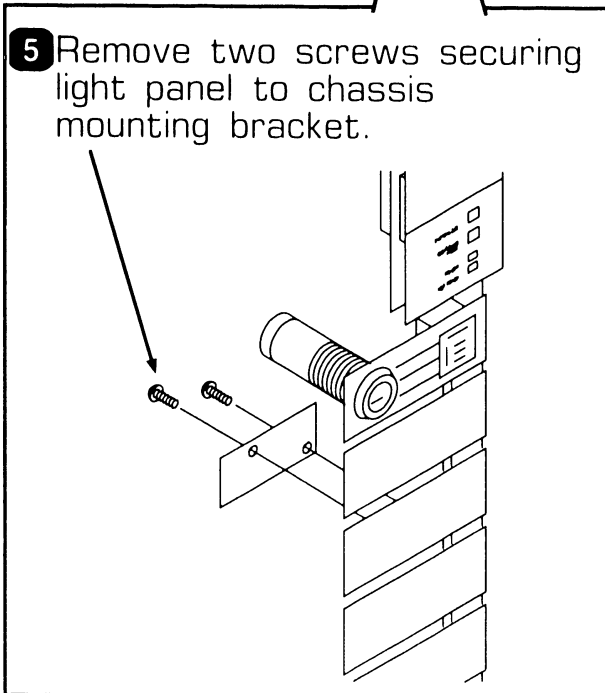
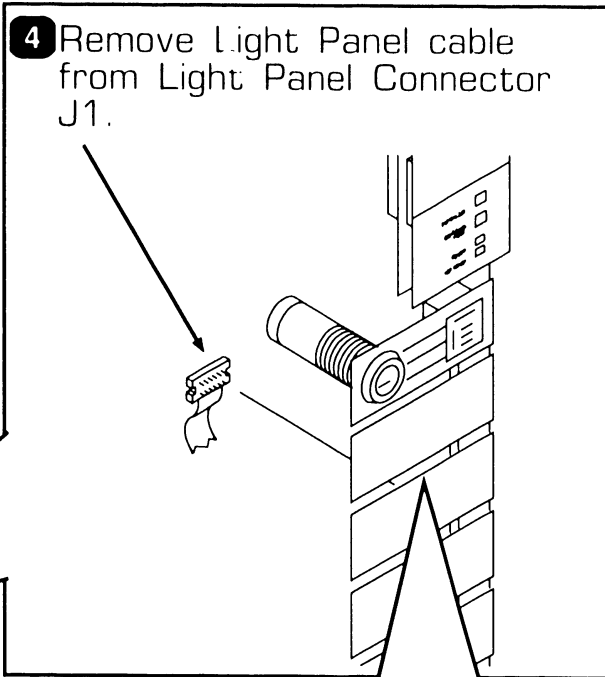
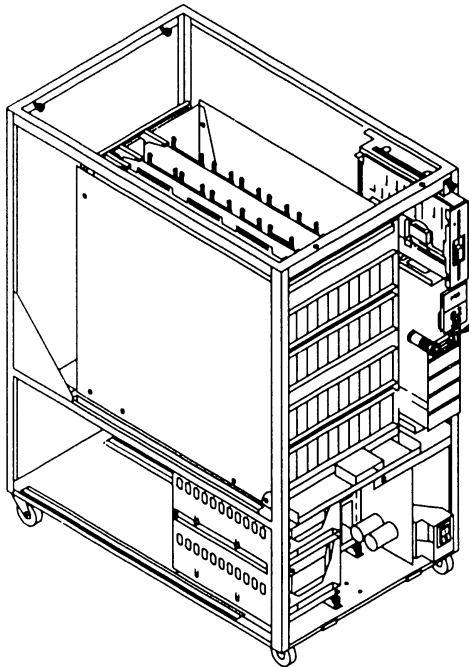

● END

7.2 Removal Procedures

REPAIR

7.2.22 Motherboard Removal (Sheet 1 of 3)

- 1 Power-off the VS-75E and disconnect ac power. (➡4.2)
- 2 Remove top cover. (➡7.2.1)
- 3 Remove front cover (➡7.2.2) and side covers. (➡7.2.3)
- 4 Remove all boards in card cage. (➡7.2.4)

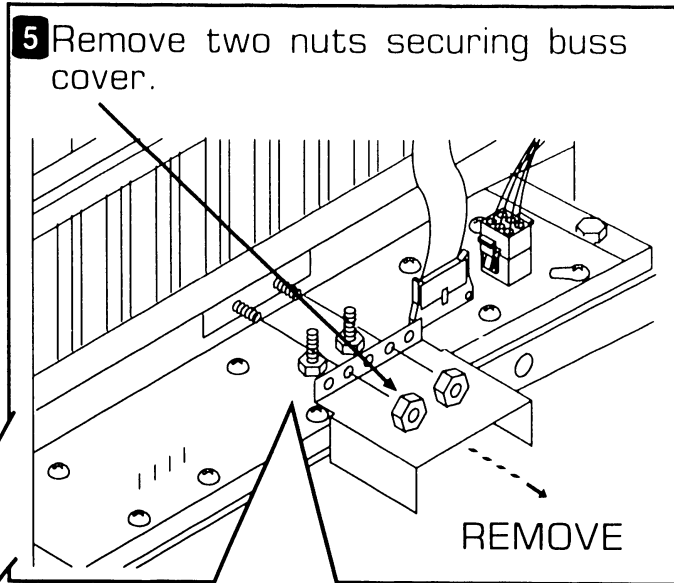
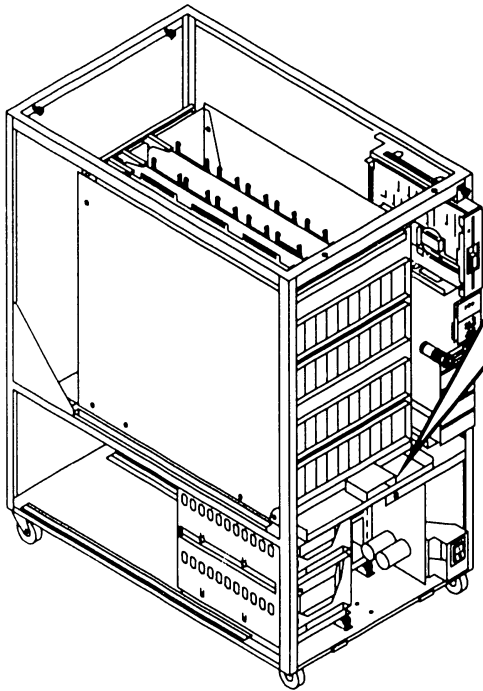

- 6 Note cable routing and remove the following cables:
- A. +5V Buss
 - B. +/-0V Buss
 - C. J30
 - D. J31

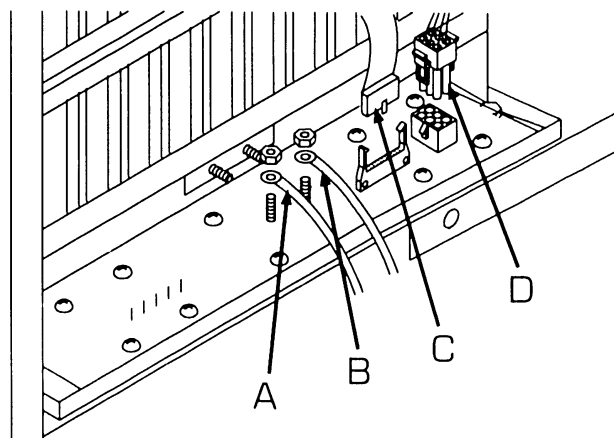

➡NEXT

7.2 Removal Procedures

REPAIR

7.2.22 Motherboard Removal (Sheet 2 of 3)

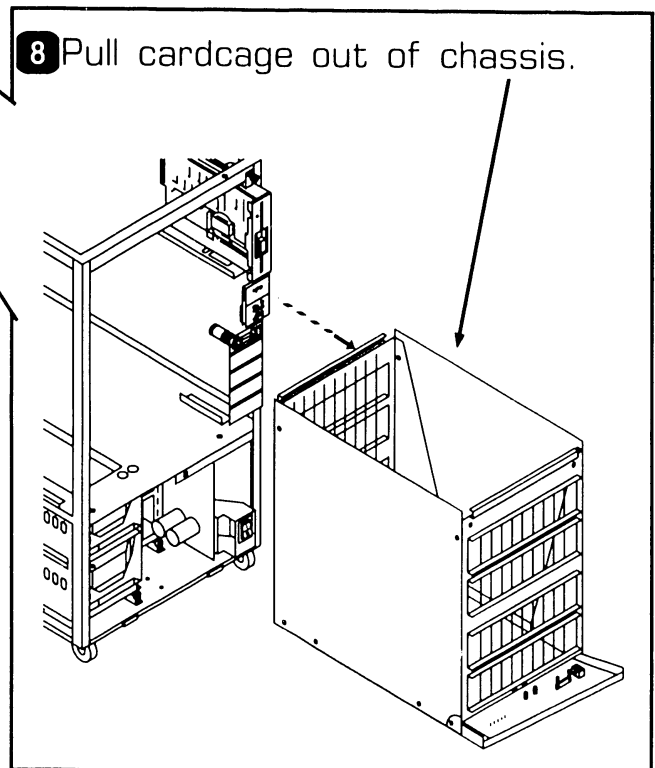
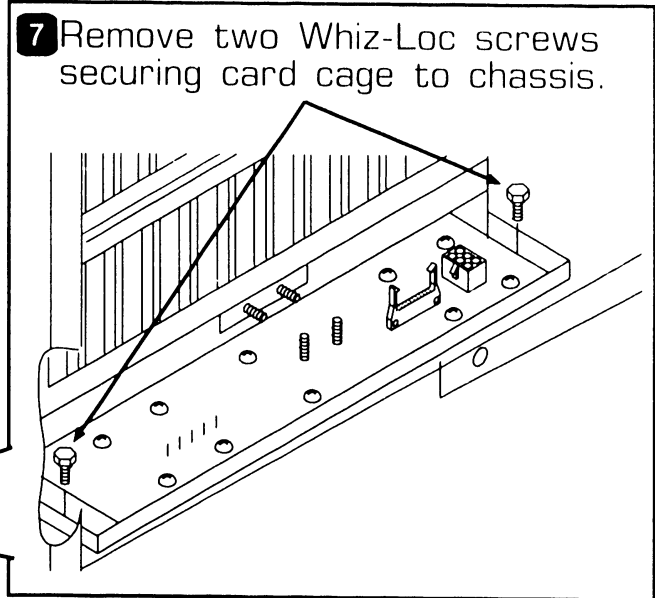
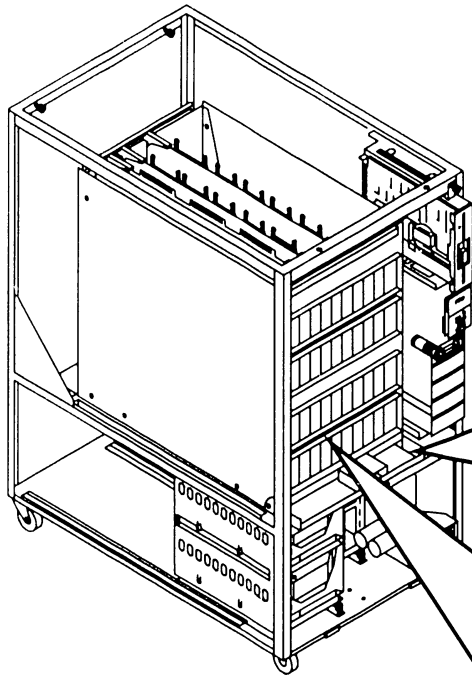

▶ NEXT

7.2 Removal Procedures

7.2.22 Motherboard Removal (Sheet 3 of 3)

9 Remove eight motherboard/base assembly mounting screws (four each side).

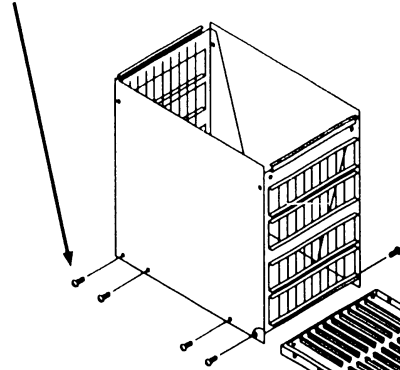

10 Slide motherboard/base assembly out of card cage.

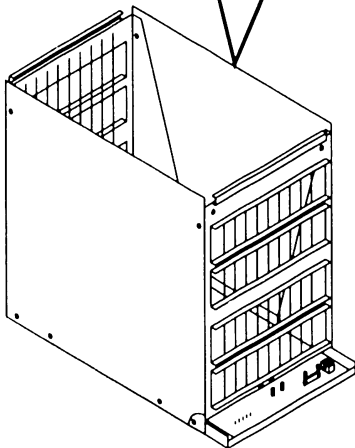

11 Remove 30 screws securing motherboard to base assembly.

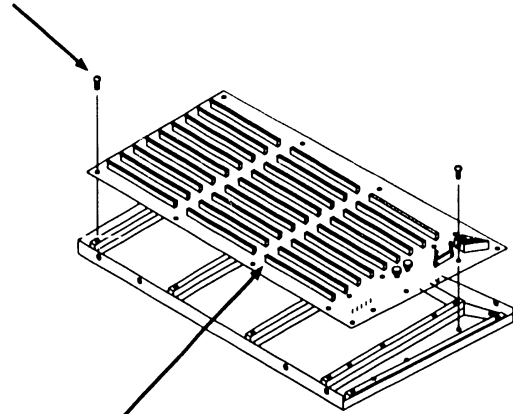

12 Remove motherboard.

● END

7.2 Removal Procedures

REPAIR

7.2.23 Half-Panel Removal (Sheet 1 of 2)

NOTE

Half-panels are interlocking. Adjacent half-panels must be loosened in order to remove and install half-panels.

Rear Panel Assembly does not have to be removed for half-panel removal.

- 1 Power-off the VS-75E and disconnect ac power. (➡4.2)
- 2 Remove top cover. (➡7.2.1)

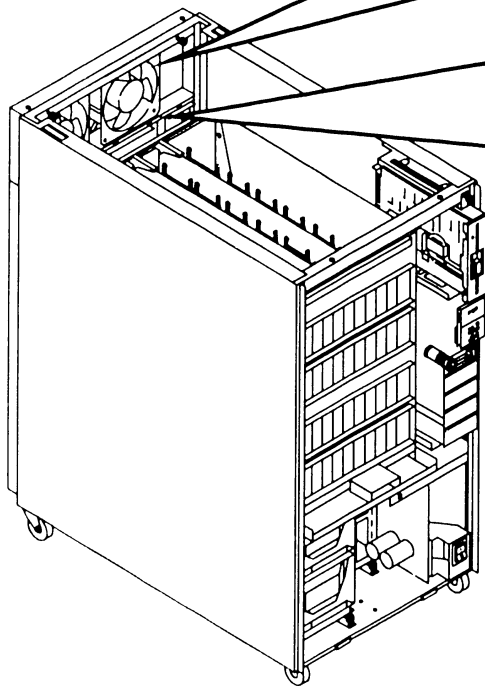

- 3 Completely loosen two captive screws securing rear panel assembly to chassis.

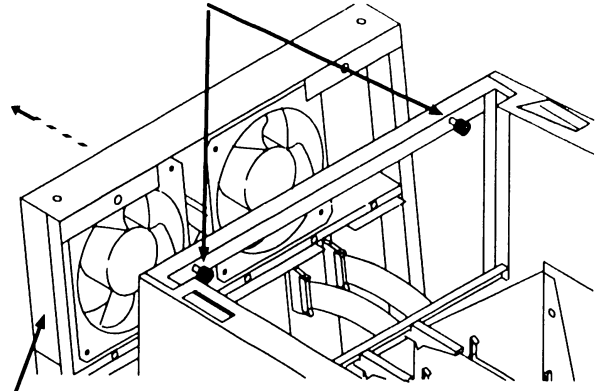

- 4 Tilt rear panel assembly out about seven inches and support in place.

- 5 Note cable locations and remove all cables attached to half-panel being replaced.

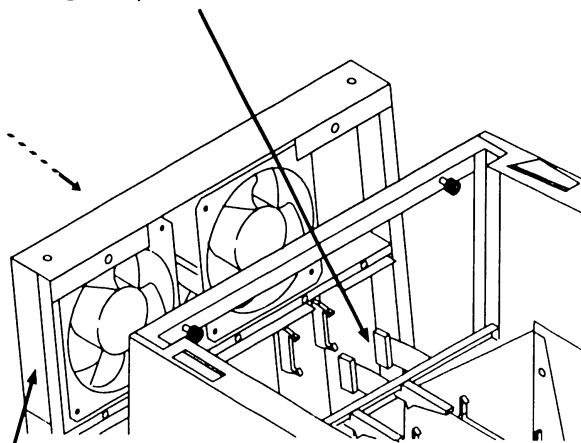

- 6 Raise and secure rear panel assembly in place.

➡NEXT

7.2 Removal Procedures

REPAIR

7.2.23 Half-Panel Removal (Sheet 2 of 2)

7 Loosen mounting screws that secure adjacent half-panels to rear panel assembly.

8 Remove two mounting screws securing half-panel being removed.

9 Remove half-panel.

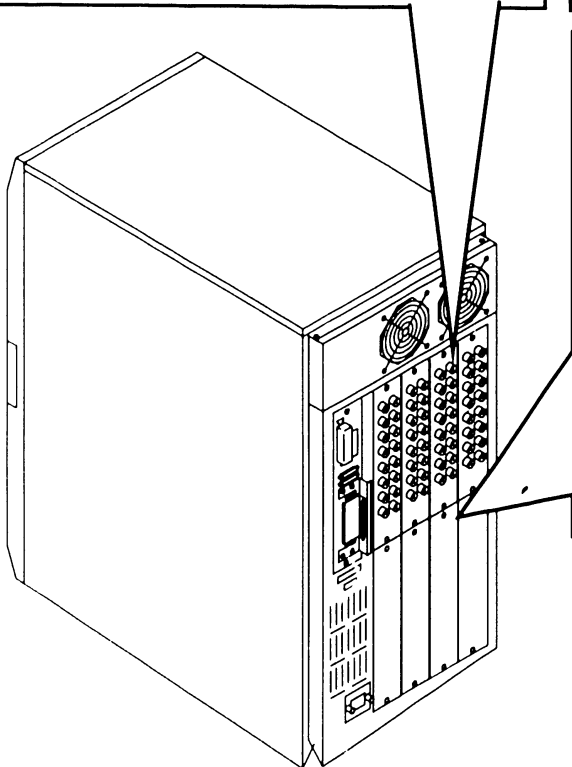

PANEL INTERLOCK

● END

7.2 Removal Procedures

REPAIR

7.2.24 SCSI Interface Cable Removal

- 1 Power-off the VS-75E and disconnect ac power. (➡4.2)
- 2 Remove top cover. (➡7.2.1)
- 3 Remove front cover (➡7.2.2) and side covers. (➡7.2.3)
- 4 Remove SCSI Interface cable from Bus Processor connector J5. (➡7.2.7)
- 5 Remove SCSI Interface cable from winchester drives. (➡7.2.7)

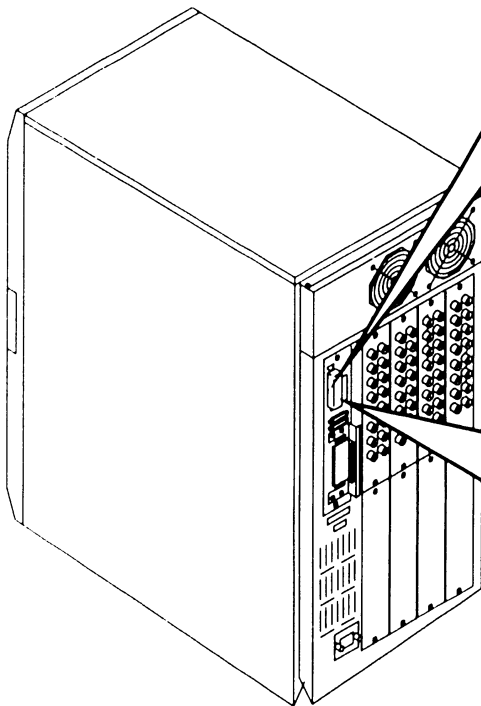

- 6 Remove SCSI port terminator.

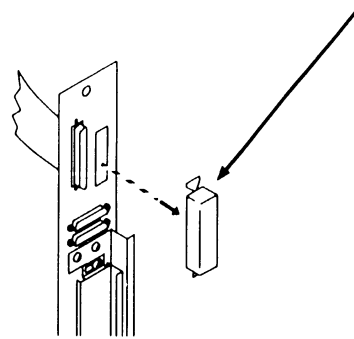

- 7 Lower rear panel assembly enough to access SCSI Interface Cable connector. (➡7.2.23)

- 8 Remove two screws securing SCSI interface cable to SCSI half-panel.

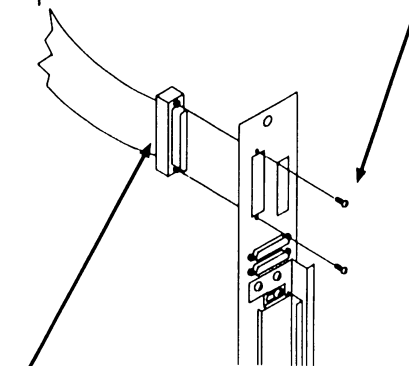

- 9 Remove SCSI cable through front of chassis.

◆ END

7.2 Removal Procedures

REPAIR

7.2.25 Dc Fan Assembly Removal

NOTE

Dc fans are replaced as an assembly.

- 1 Power-off the VS-75E and disconnect ac power. (▶4.2)
- 2 Remove top cover. (▶7.2.1)

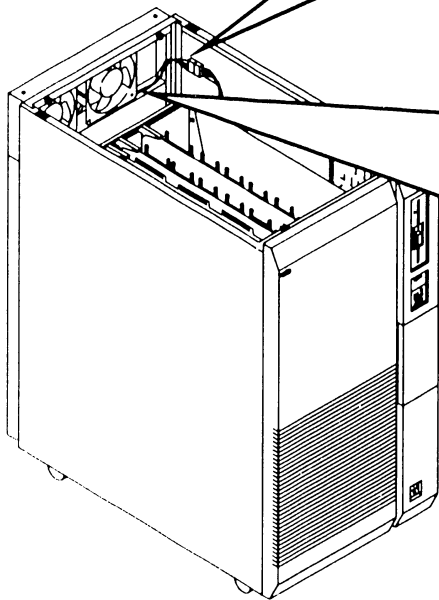

- 3 Disconnect Dc fan power cable.

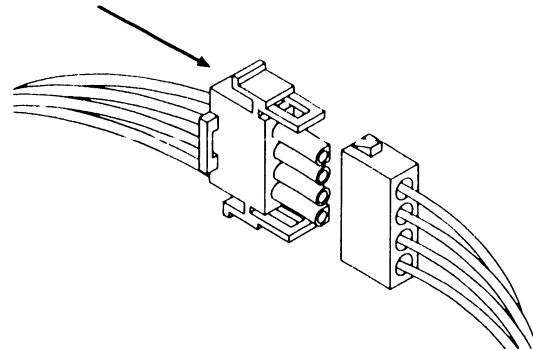

- 4 Remove eight screws (4 per fan) securing Dc fan assembly to rear panel assembly.

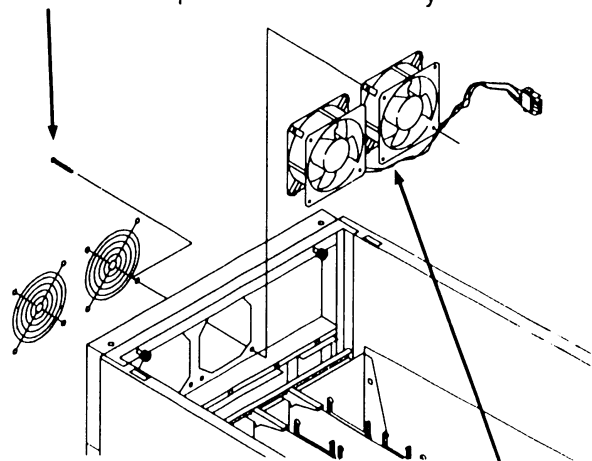

- 5 Remove Dc fan assembly from rear panel assembly.

◆ END

SECTION

8

ADJUSTMENTS

SECTION 8 CONTENTS

SECTION 8 ADJUSTMENTS

	<u>Page</u>
8.1 TOOLS AND EQUIPMENT	8-1
8.1.1 Special Tools	8-1
8.2 ELECTRICAL ADJUSTMENTS	8-2
8.2.1 Power Supply Voltage Adjustments	8-2

8.1 Tools and Equipment

8.1.1 Special Tools

No special tools or equipment are required to perform alignments and adjustments on the VS-75E main-frame. All adjustments and alignments can be accomplished using a standard Wang CE tool kit which includes:

- Small flat blade plastic screwdriver
- Digital multimeter

● END

8.2 Electrical Adjustments

ADJUSTMENTS

8.2.1 Power Supply Voltage Adjustments (sheet 1 of 3)

WARNING

DO NOT OPEN SWITCHING POWER SUPPLY UNDER ANY CIRCUMSTANCE. EXTREMELY DANGEROUS VOLTAGE AND CURRENT LEVELS, IN EXCESS OF 300 VOLTS DC AND UNLIMITED CURRENT, ARE PRESENT WITHIN POWER SUPPLY. DO NOT ATTEMPT TO REPAIR POWER SUPPLY; IT IS FIELD REPLACEABLE ONLY.

- 1 Power down mainframe. (➡4.2)
- 2 Remove top cover. (➡7.2.1)
- 3 Remove front cover. (➡7.2.2)

- 5 Power-up VS-75E mainframe. (➡4.1)
- 6 Connect common lead of DVM to TP1 of motherboard.

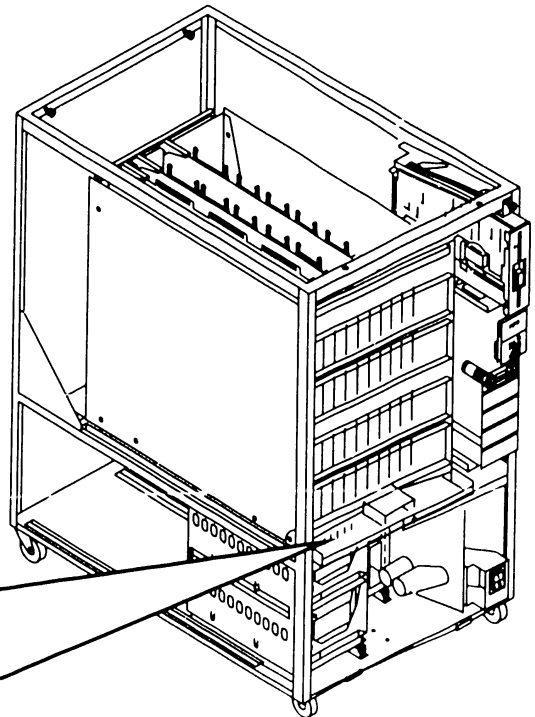
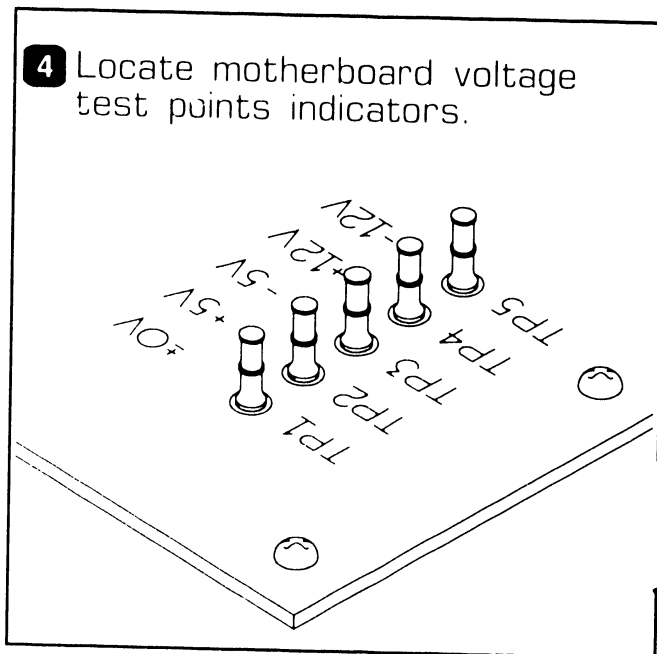

➡NEXT

8.2 Electrical Adjustments

ADJUSTMENTS

8.2.1 Power Supply Voltage Adjustments (sheet 2 of 3)

- 7 Connect DVM to TP2 - TP5 on motherboard to verify DC voltage limits.

Test Point	Voltage	Limits (VDC)
TP2	+5V (ADJ)	+4.95V to +5.05V
TP3	-5V (Fixed)	-4.95 to -5.05V
TP4	+12V (ADJ)	+11.85 to +12.15
TP5	-12V (Fixed)	-11.85 to -12.15

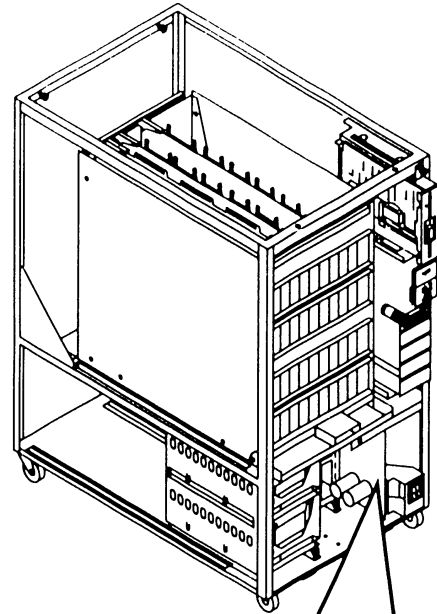

- 8 Adjust +5V ADJ pot to acceptable voltage levels.

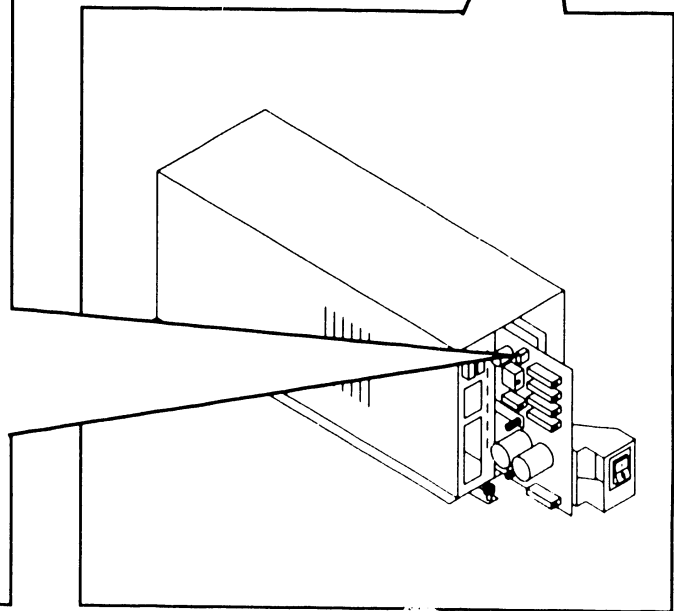
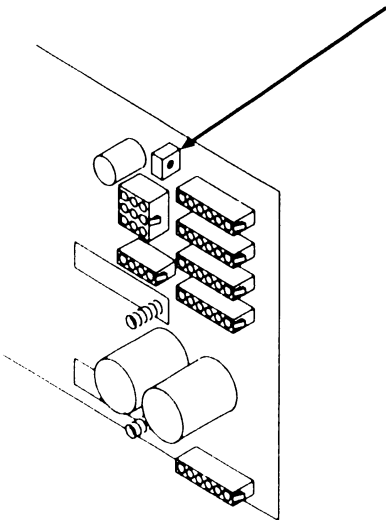

◆ NEXT

8.2 Electrical Adjustments

ADJUSTMENTS

8.2.1 Power Supply Voltage Adjustments (sheet 3 of 3)

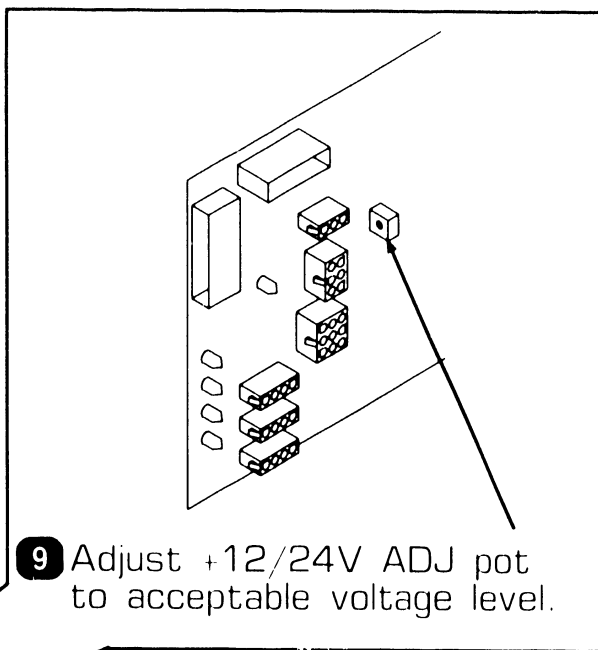
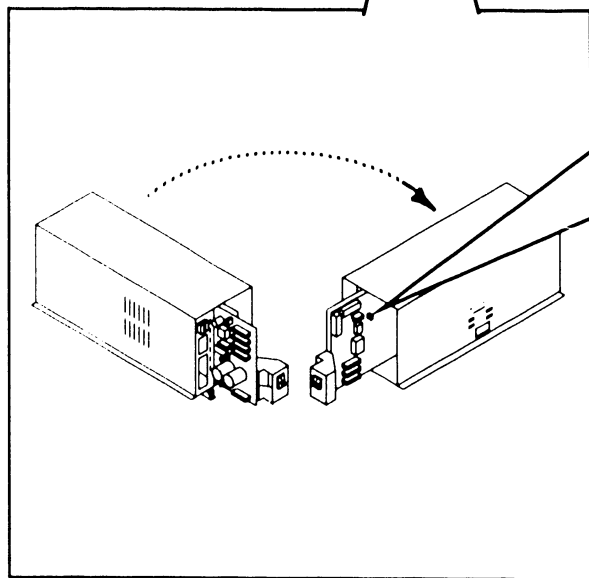
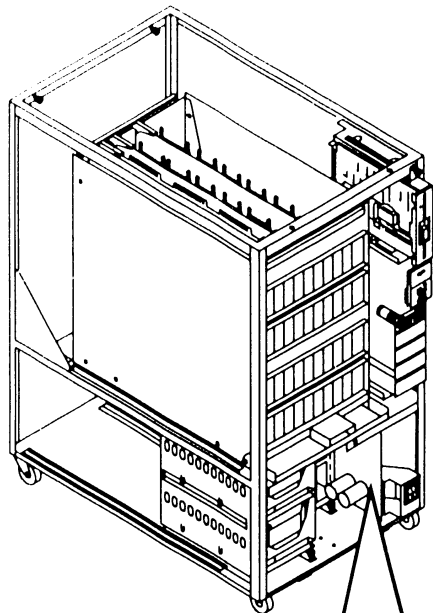

9 Adjust +12/24V ADJ pot to acceptable voltage level.

10 Power-down mainframe (➡4.2).

11 Replace covers.

● END

SECTION

9

UNPACKING

AND

SETUP

SECTION 9 CONTENTS

SECTION 9 UNPACKING AND SET-UP

	<u>Page</u>
9.1 INSTALLATION SITE CHECK	9-1
9.2 TOOLS AND EQUIPMENT	9-2
9.3 UNPACKING PROCEDURES	9-3
9.3.1 Unpacking And Inspecting VS-75E Computer System	9-3
9.3.2 Unpacking Peripherals	9-5
9.3.3 Claims Information	9-6
9.3.4 Initial Set-Up	9-7
9.4 INSPECTION	9-8
9.4.1 VS-75E Mainframe Inspection	9-8
9.4.2 Peripheral Inspection	9-10
9.4.3 VS-75E Power Service Requirements	9-11
9.5 SWITCH SETTING	9-13
9.5.1 Line Voltage Select Switch	9-13
9.6 CONNECTIONS	9-14
9.6.1 Mainframe AC Power Connection	9-14
9.6.2 Workstation 0 Connection	9-15
9.7 INITIAL MAINFRAME DC VOLTAGE CHECK	9-16

SECTION 9 CONTENTS

SECTION 9

UNPACKING AND SET-UP (CONT.)

	<u>Page</u>
9 8 SOFTWARE INSTALLATION	9-17
9 8 1 Initial Program Load (IPL)	9-17
9 8 2 System Generation (GENEDIT) Procedures	9-29
9 9 STAND-ALONE UTILITIES (SAU)	9-36
9 9 1 Copy Utility	9-37
9 9 2 Loading SAU	9-38
9 9 3 Running SAU	9-39
9 9 4 SAU Relabel Procedures	9-48
9 10 REMOTE MAINTENANCE	9-50
9 11 OPTION BOARD UPGRADE INSTALLATION	9-51
9 11 1 Async Option (25V36) Installation	9-52
9 11 2 1-Port TC DA Option (25V76-1) Installation	9-54
9 11 3 2-Port TC DA Option (25V76-2) Installation	9-57
9 11 4 2-Port SMD DA Option (25V50-2) Installation	9-60
9 11 5 4-Port SMD DA Option (25V50-4) Installation	9-62
9 11 6 High-Speed 4-Port SMD DA Option (25V98-4) Installation ..	9-64
9 11 7 UISIO Board Option (25V67) Installation	9-66
9 11 8 RSF Board Option (25V14) Installation	9-68
9 12 VS-75E UPGRADE KITS	9-70
9 13 VS SMALL CABLE CONCENTRATOR	9-71
9 14 LATEST PCB REVISIONS	9-72

9.1 UNPACKING AND SETUP

Installation Site Check

Proper equipment location and site preparation are important for reliable operation of the VS-75E Computer System. The Customer Engineer is responsible for installation of all models of the VS-75E Computer System and peripherals. The following conditions must be met:

- All site plans should have been approved by both the customer and a Customer Service Representative.
- All building alterations must have been completed and inspected.
- All electrical wiring, air conditioning, and telecommunications (TC) modifications must have been installed and tested. (The following TC equipment should have been ordered for remote maintenance support, if option is elected:)

d. One of the following modular connecting blocks for the telephone:

1. RJ11C for desk top telephone
2. RF11W for flush mount wall telephone

Pre-installation inspection is to be performed two weeks prior to delivery of equipment. At this time, the service representative will check the site for compliance with VS site specifications. The service representative will bring any unsatisfactory conditions noted to the attention of the customer for correction.

NOTE

Items b, c, and d are not required if the modem used is a Wang Telemodem, WTM2400.

- a. Telephone line (Dedicated line is not required.)
- b. Telephone, rotary or pushbutton
- c. WA3451 Modem

◆ END

9.2 UNPACKING AND SETUP

Tools and Equipment

- Standard CE tool kit
WUI#: 726 9401
- Digital Multimeter

◆ END

9.3 UNPACKING AND SETUP

9.3 Unpacking Procedures

9.3.1 Unpacking and Inspecting VS-75E Computer System (Sheet 1 of 2)

WARNING

The VS-75E Computer System weighs approximately 135 pounds (61.4 Kg). Be sure adequate help is available to perform any cabinet movement required.

NOTES

Part number prefix 157 50Hz ac line frequency mainframes
Part number prefix 177 60Hz ac line frequency mainframes

- 1 Check all packing slips to make sure the proper equipment has been delivered. Refer to model number information contained in the following table. After checking packing slips, inspect all shipping containers for damage (crushed corners, punctures, etc.). If damage is noted, notify your manager.

VS-75E Models

<i>Model Number</i>	<i>WLI/P/N</i>	<i>Description</i>
VS75E-2DM	157 177-7545	VS-75E, 2MB Main Memory, One 145 MB Disk
VS75E-4DM	157 177-7546	VS-75E, 4MB Main Memory, One 145 MB Disk
VS75E-8DM	157 177-7547	VS-75E, 8MB Main Memory, One 145 MB Disk

►NEXT

9.3 UNPACKING AND SETUP

9.3 Unpacking Procedures

9.3.1 Unpacking and Inspecting VS-75E Computer System (Sheet 2 of 2)

- 2 Cut plastic straps securing top cover and carton tube to pallet.
- 3 Remove top cover, top cushion and carton tube.
- 4 Remove two cushion blocks at base of cabinet.
- 5 Remove plastic bag covering cabinet.
- 6 Remove two shipping bolts.
- 7 Roll (and slide) cabinet off the pallet.
- 8 Visually inspect the unit for external damage.

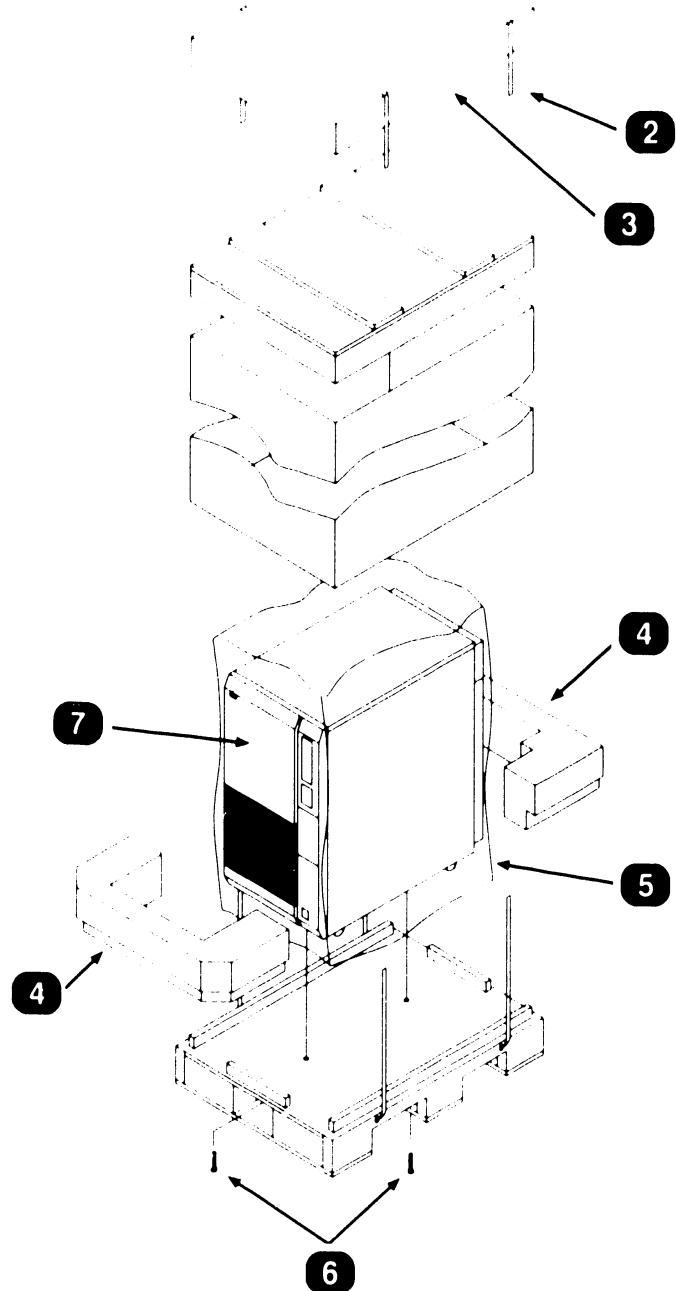

● END

9.3 UNPACKING AND SETUP

9.3 Unpacking Procedures

9.3.2 Unpacking Peripherals

- 1 Unpack all peripherals according to the procedures outlined in the applicable maintenance manuals. As each unit is unpacked, check it for any obvious shipping damage. If damage is noted, notify your manager.

● END

9.3 UNPACKING AND SETUP

9.3 Unpacking Procedures

9.3.3 Claims Information

If damage is discovered during unpacking or inspection, notify your service manager.

● END

9.3 UNPACKING AND SETUP

9.3 Unpacking Procedures

9.3.4 Initial Set-Up

- 1 Move the cabinet to its permanent location.
- 2 Once the cabinet is in place, check service clearances to be at least 4 feet by 4 feet (1.2 meters by 1.2 meters).

CAUTION

THIS COMPUTER EQUIPMENT HAS BEEN VERIFIED AS FCC CLASS A. IN ORDER TO MAINTAIN COMPLIANCE WITH FCC CLASS A VERIFICATION, THE FOLLOWING CONDITIONS MUST BE ADHERED TO DURING NORMAL OPERATION OF EQUIPMENT.

- ALL COVERS MUST BE ON THE SYSTEM AND SECURED IN THE PROPER MANNER.
 - ALL INTERNAL CABLES MUST BE ROUTED IN THE ORIGINAL MANNER WITHIN THE CABLE CLAMPS PROVIDED FOR THAT PURPOSE.
 - ALL EXTERNAL CABLES MUST BE SECURED AND THE PROPER CABLE USED TO ENSURE THAT CABLE SHIELDING IS PROPERLY GROUNDED TO THE CABLE CLAMPS PROVIDED.
 - ALL HARDWARE IS PROPERLY SECURED.
-

● END

9.4 UNPACKING AND SETUP

9.4 Inspection

9.4.1 VS-75E Mainframe Inspection (Sheet 1 of 2)

NOTE

Quality assurance procedures and tests have shown that VS mainframes arriving on customer's premises require only visual inspection, voltage checks, software loading, and cabling. Therefore, the following inspection and installation procedures for all VS mainframe products are in effect.

DO NOT REMOVE PRINTED CIRCUIT BOARD FOR INSPECTION

DO NOT CLEAN PRINTED CIRCUIT BOARD CONTACTS
WITH AN ERASER

INSPECT CPU MAINFRAME VISUALLY

REPORT INSTALLATION PROBLEMS ON THE INSTALLATION REPORT
AND STATE SPECIFIC CAUSES OF FAILURE

- 1 Remove top cover (➡7.2.1)
- 2 Remove front cover (➡7.2.2) and side covers (➡7.2.3)
- 3 Remove the shipping protector from the floppy diskette drive.
- 4 Inspect the interior of mainframe for packing material and shipping damage such as broken connectors and loose fastening hardware.

9.4 UNPACKING AND SETUP

9.4 Inspection

9.4.1 VS-75E Mainframe Inspection (Sheet 2 of 2)

- 5 Refer to the shipping list to make sure that the correct circuit boards have been shipped.
- 6 Make sure all circuit boards are properly seated in the backplane.
- 7 Inspect the power supply for damage and loose connections. At this time make sure all power supply connections are tight.
- 8 If necessary, vacuum clean the unit. (►5.4)
- 9 Do not reassemble the mainframe at this time.
- 10 If damage is discovered at any time during the inspection, follow the reporting procedure (►9.3.3).

● END

9.4 UNPACKING AND SETUP

9.4 Inspection

9.4.2 Peripheral Inspection

Inspect each peripheral according to procedures outlined in the applicable maintenance manuals. If damage is discovered at any time during the peripheral inspection, follow the reporting procedure (▶9.3.3).

● END

9.4 UNPACKING AND SETUP

9.4 Inspection

9.4.3 VS-75E Power Service Requirements (Domestic) (Sheet 1 of 2)

The inspection and electrical checks are required to make sure the power source and receptacle meet all specified requirements before proceeding with the mainframe and peripheral installation.

NOTE

The following procedures are for domestic 115 Vac, 60 Hz installation. Installation outside the continental USA, requiring other configurations and voltages, must be dealt with on a site by site basis.

The neutral and ground leads must be connected together and to earth ground at the building main input power panel.

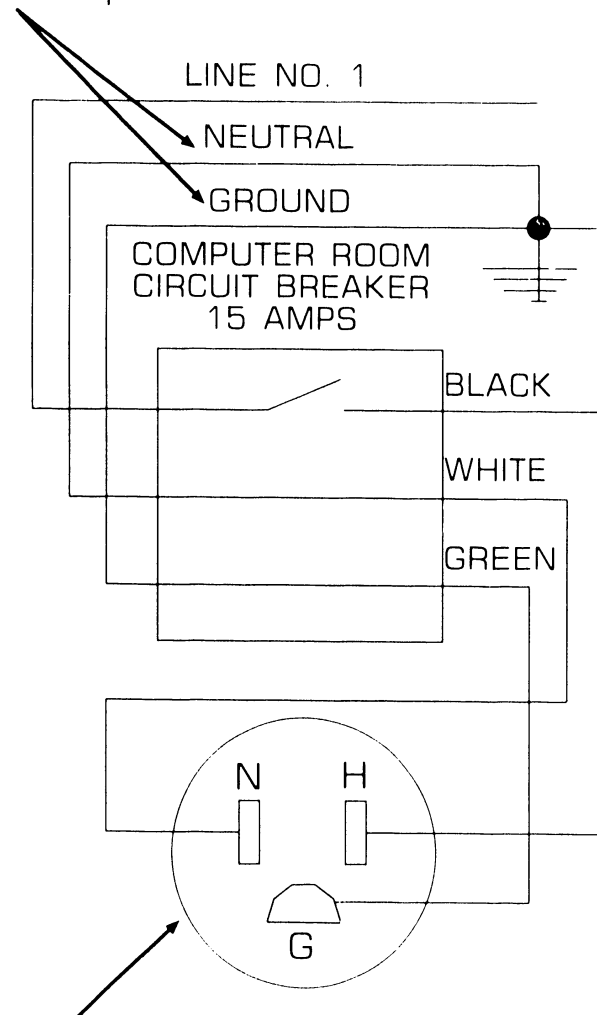

NEMA 5-151G, 120V, 15A, 60Hz,
SGL Phase 2-Pole, 3 wire.

Ground lead must be same or
heavier gauge than hot lead.

➡NEXT

9.4 UNPACKING AND SETUP

9.4 Inspection

9.4.3 VS-75E Power Service Requirements (Domestic) (Sheet 2 of 2)

CAUTION

Failure to verify input power service can result in serious damage to the mainframe circuits and to connected peripherals.

- 1 Using a digital voltmeter, perform ac receptacle input voltage checks as outlined in the following table.

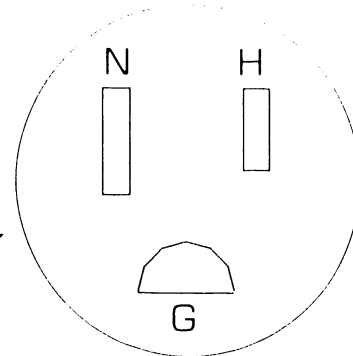

5-151G

Test Points	Voltage Measurements
-------------	----------------------

H to N	102 to 132 Vac
H to G	102 to 132 Vac
G to N	-0.5 to +0.5 Vac (See Note)

NOTE

If a difference in potential of more than 0.5 Vac exists between ground and neutral, notify the responsible electrician that the power source is **NOT ACCEPTABLE**.

● END

9.5 UNPACKING AND SETUP

9.5.1 Switch Settings

9.5.1 Line Voltage Select Switch

- 1 Remove top cover. (➔7.2.2)
- 2 Remove front cover. (➔7.2.3)
- 3 Remove side cover. (➔7.2.4)

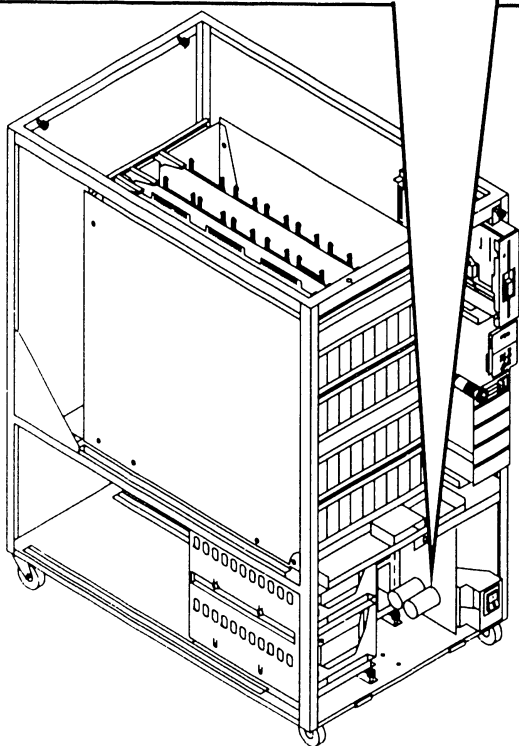
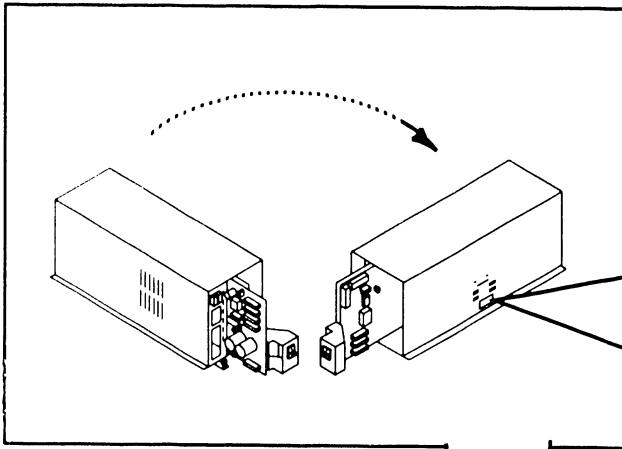

- 4 Verify/set power supply voltage select switch to correct line voltage setting.

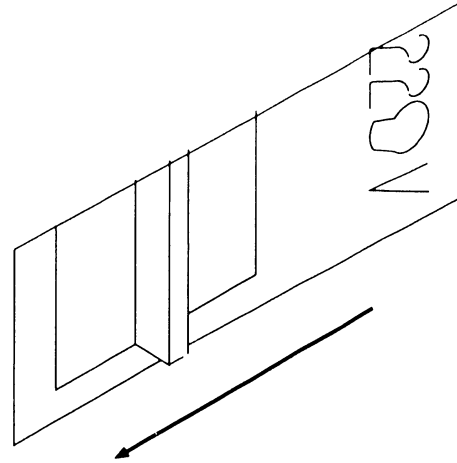

Set for 220 Vac

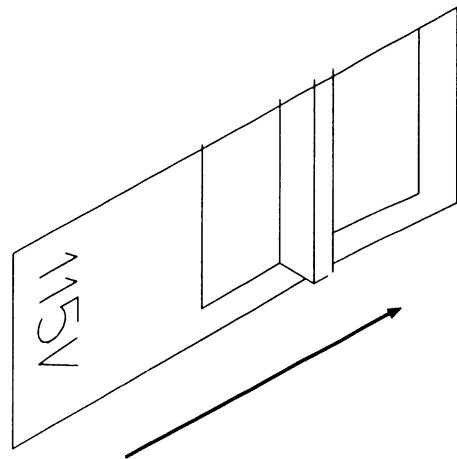

Set for 115 Vac

◆ END

9.6 UNPACKING AND SETUP

9.6.1 Connections

9.6.1 Mainframe AC Power Connection

- 1** Plug power supply power cable in power supply receptacle. Secure with screws provided.

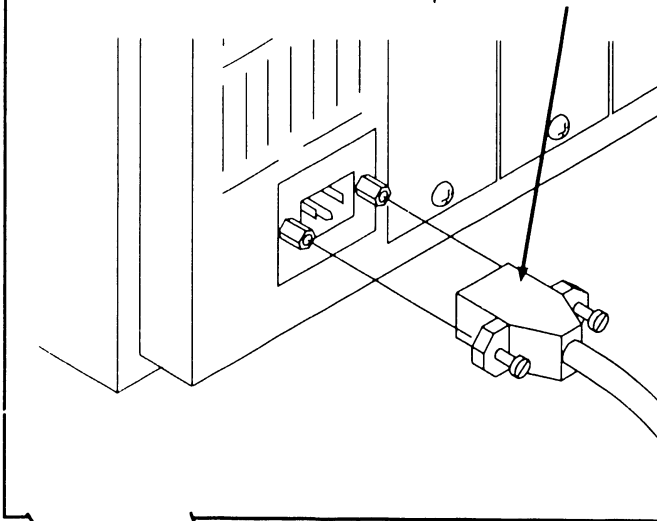

- 2** Be sure the mainframe AC On/Off Switch is in the Off (0) position. Plug the power connector into the power source receptacle.

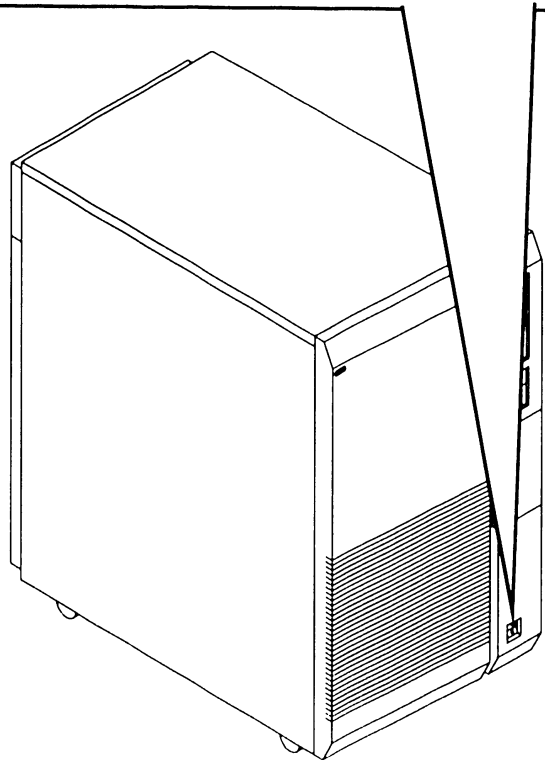
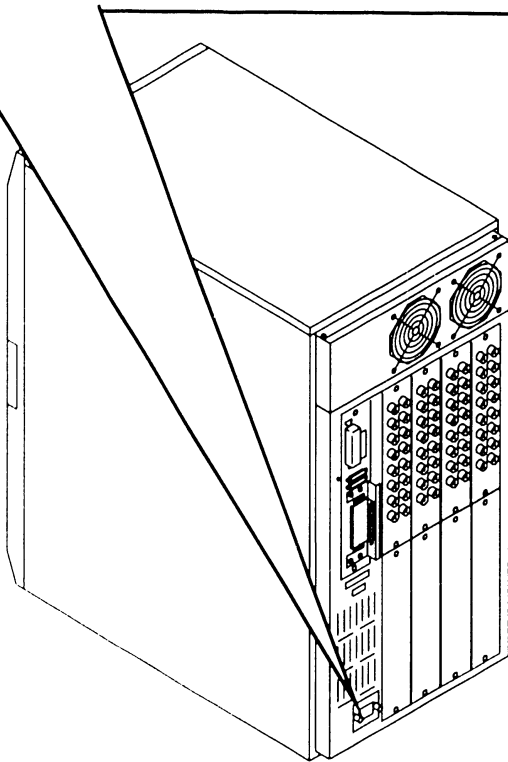
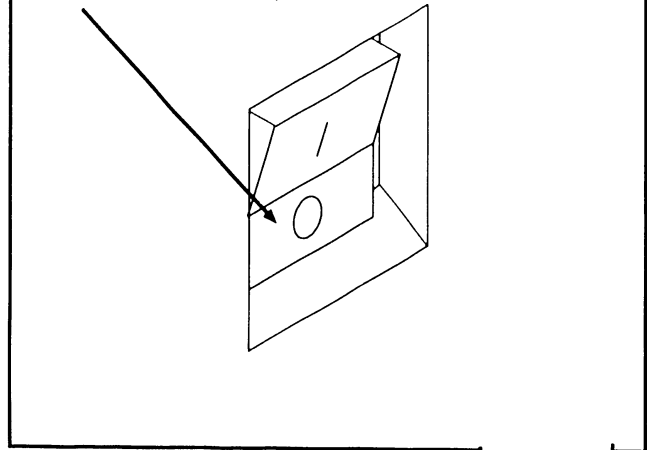

◆ END

9.6 UNPACKING AND SETUP

9.6.2 Connections

9.6.2 Workstation 0 Connection

NOTES

Workstation 0 must be a serial workstation with a minimum of 32K memory.

If Remote Maintenance Option is installed, Workstation 0 must be a Professional Computer.

- 1 Connect Workstation 0 to EAPA 0 port 0 BNC/TNC connectors.

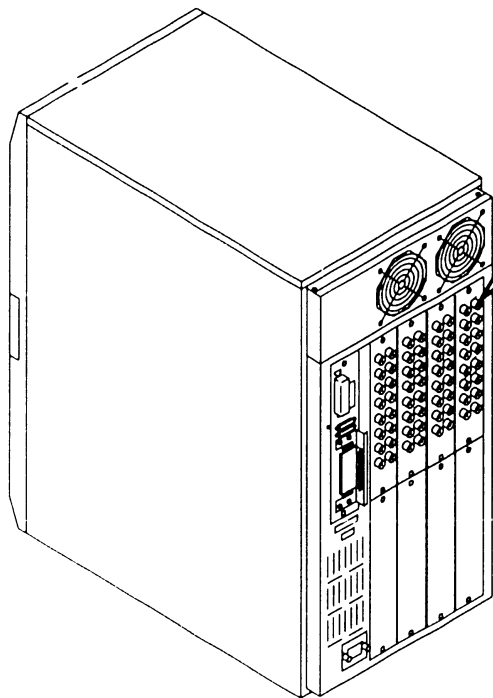
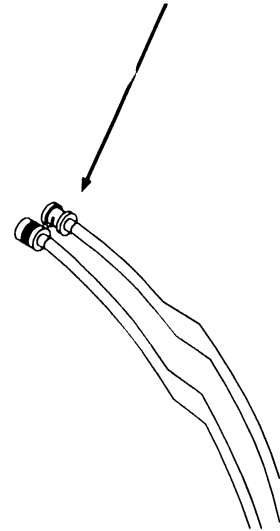

● END

9.7 UNPACKING AND SETUP

Initial Mainframe DC Voltage Check

- 1 Remove top cover (▶7.2.1).
- 2 Remove front cover (▶7.2.2).
- 3 Power-on mainframe (▶4.2).
- 4 Verify power supply LEDs are illuminated (▶3.4.2).
- 5 Check/adjust power supply voltages (▶8.2).
- 6 If voltages cannot be brought within tolerance, replace power supply (▶7.2.16).
- 7 If the voltages are correct, the system can be IPL'ed (▶9.8).

◆ END

9.8 UNPACKING AND SETUP

9.8 Software Installation

9.8.1 Initial Program Load (IPL) (Sheet 1 of 12)

CAUTION

Never switch mainframe power ON or OFF when a floppy diskette is mounted in the drive.

Perform power-on procedures as follows. Improper power-on procedure may damage disk drive VTOC.

- 1 Power-on external disk drives.
- 2 Power-on workstation 0.

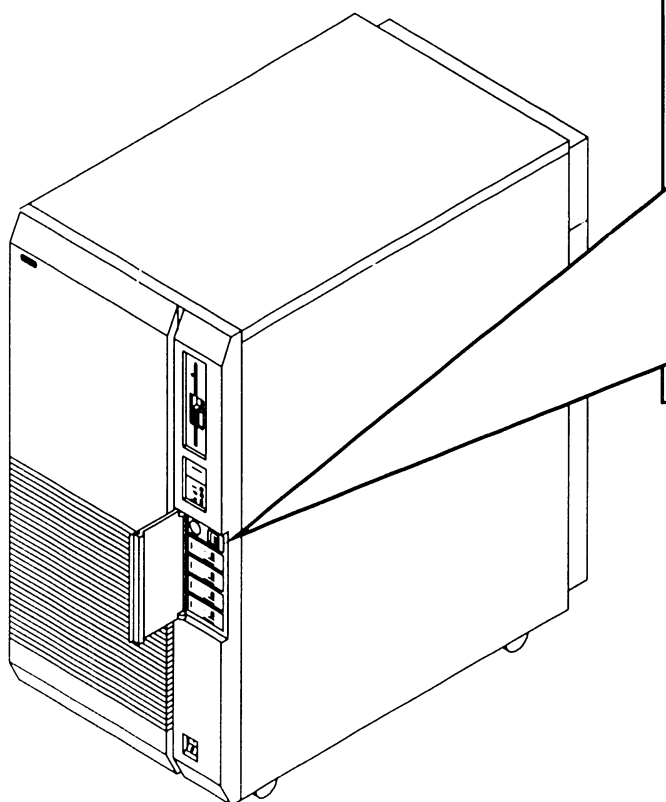

3 Set Boot Device Switch to selected boot drive.

Floppy = Floppy Drive
Fixed = SCSI-embedded Drive at address 6
EXT. = External drive on SMD port 0

A detailed diagram of the control panel shown in the previous image. It features a circular dial on the left with a pointer. To the right of the dial are three indicator lights labeled 'LOCAL CONTROL', 'REMOTE DIAGNOSTIC', and 'REMOTE CONTROL'. Further right is a 'BOOT DEVICE' switch with three positions: 'FLOPPY', 'FIXED', and 'EXT.'. An arrow points from the 'EXT.' label in the text above to the 'EXT.' position of the switch.

▶NEXT

9.8 UNPACKING AND SETUP

9.8 Software Installation

9.8.1 Initial Program Load (IPL) (Sheet 2 of 12)

- 4** Set Local/Remote Diagnostic/Remote Control keyswitch to Local position.

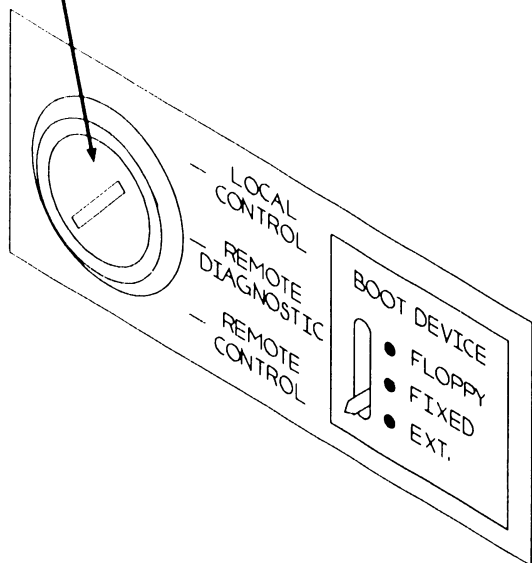

- 5** Press '1' on VS-75E cabinet Ac power switch.

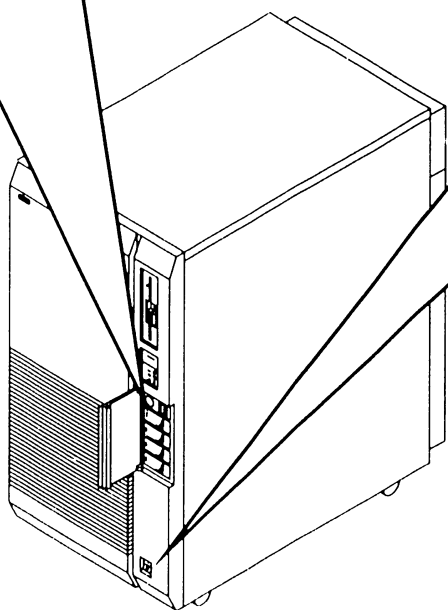
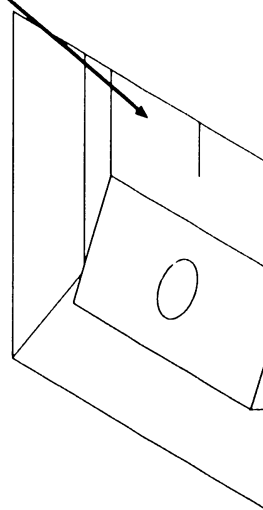

▶NEXT

9.8 UNPACKING AND SETUP

9.8.1 Software Installation

9.8.1 Initial Program Load (IPL) (Sheet 3 of 12)

- 6 Make 'ready' external drives.
- 7 Diagnostic LEDs cycle through Bus Processor BIT tests error codes for 45 seconds or display error code (▶6.2.3). The following message is displayed on WSO.

IPL MONITOR

Initialization in Progress

- 8 Small VS BP2 Class Self Test Package IPL Drive Selection screen is displayed on WSO at end of successful completion of BIT power-up test.

NOTE

When screen prompt "Default Test and IPL in Several Seconds" is displayed, pressing any key except Space Bar, Up Arrow, Down Arrow, PF1, PF8, or RETURN will halt the automatic IPL sequence allowing additional time for drive selection.

Small VS BP2 Class Self Test Package Version R2xxx
IPL Drive Selection
Bootstrap Volume = SYSTEM

Device	Capacity	Type	Volume	Status
2270V4	1.2 MB	Dsket		
■2269V4	145 MB	Fixed	SYSTEM	
2269V4	145 MB	Fixed	DATA	

Default Test and IPL in Several Seconds, System Hardware Status

Position Cursor to Indicated Device and Select:

(ENTER)Test & IPL (PF1)IPL Only (PF8)Stand Alone Diagnostic Monitor

▶NEXT

9.8 UNPACKING AND SETUP

9.8 Software Installation

9.8.1 Initial Program Load (IPL) (Sheet 4 of 12)

- 9 Position cursor next to drive the operating system is to be loaded from. Press ENTER. Small VS BP2 Class Self-Test Monitor Screen is displayed and Self-Test begins to run.

```
Small VS BP2 Class Self Test Monitor Package   Version Rxxxx
System hardware Status
System Volume = SYSTEM
```

Status	Diagnostic
Passed	(SIO) Serial Data Link Test
Passed	(BP) USART Loopback Verification Test
Running	(CP7) CM/Communications Test
	(CP7) Operational Test
	(CP7) Integrity Test
	(MM) CPU/Cache/Main Memory Test
	(BP) BP/Main Memory DMA Test
	(MM) Dual Processor M/M Test

- 10 Self-Test monitor screen indicates the VS-75E is testing system components. Status of each test is displayed with the message sequence: 'Loading', 'Running', 'Passed', 'Non-Fatal Error', or 'Fatal Error'. If the status is 'Passed' the system is ready to begin initialization.

NOTE

Non-Fatal Error messages and Fatal Error messages will display the error code (▶6.4.4).

▶NEXT

9.8 UNPACKING AND SETUP

9.8 Software Installation

9.8.1 Initial Program Load (IPL) (Sheet 5 of 12)

- 11** When Self-Test Monitor completes, all intelligent PCAs in the system report their Self-Test status (pass or fail) via the Small VS BP2 Class Self Test Package Option Board Status screen. The message 'Loading Operating System in 10 seconds' will then be displayed.

```
Small VS BP2 Class Self Test Package   Version Rxxxx
System hardware Status
System Volume = SYSTEM
```

Status	Option Board
Passed	25V76-1

Loading Operating System in 10 seconds

- 12** Press 'ENTER' to bypass the 10 second delay and load operating system immediately or wait the 10 seconds. The following message is displayed.

Loading System Microcode

►NEXT

9.8 UNPACKING AND SETUP

9.8 Software Installation

9.8.1 Initial Program Load (IPL) (Sheet 6 of 12)

- 13 In about 60 seconds, the following message appears on WSO and the Not Read LED turns off.

Loading Complete, Beginning System Initialization

▶NEXT

9.8 UNPACKING AND SETUP

9.8 Software Installation

9.8.1 Initial Program Load (IPL) (Sheet 7 of 12)

14 The SYSGEN Screen is displayed on WSO.

15 The SYSGEN screen displays the name of the configuration file last used (SYSFILE Field). Enter a valid configuration file name in the field 'SYSFILE'. If the system is using communications, specify the communications configuration file name and library.

NOTE

If a configuration file has not been created, the system should be IPL'ed as one workstation and one disk (PF1 key) to allow system configuration file creation using GENEDIT (►9.8.2).

* * * MESSAGE M001 BY SYSGEN

INFORMATION REQUIRED BY PROGRAM @SYSGEN@

Active Subprogram is @SYSGEN@

Copyright, Wang Laboratories, INC. 1985

Specify the name of the system configuration file and press (ENTER)

-or-

Press [1] to use one workstation and one disk.

SYSFILE= _____
SYSLIB = _____

Specify the communications configuration file to be used, if any

COMMFIL = _____
COMMLIB = _____

Inhibit logons at all workstations?
Load Microcode to all Devices?
Inhibit Dumping Continuable Halts?

LOGONS = NO
LMCODE = NO
CNDUMP = NO

►NEXT

9.8 UNPACKING AND SETUP

9.8 Software Installation

9.8.1 Initial Program Load (IPL) (Sheet 8 of 12)

16 Respond to prompts as follows:

'Inhibit Logons at all workstations? Logons NO□'

This prompt offers the options to inhibit logon operations for all workstations. If YES is answered, all workstations except WSO will be inhibited from logon operations. Default value is NO.

'Load Microcode to all Devices? LMCODE = NO□'

This prompt allows optional loading of microcode to all devices on the system with loadable microcode, including remote workstations. (Note that most devices load microcode when the device is first powered-on). If YES is selected, the system loads microcode to all microcode loadable devices, thus slowing down the IPL process significantly. Default value is NO.

'Inhibit Dumping Continuable Halts? CNDUMP = NO□'

This prompt enables or disables continuable dumps. If YES is selected, the system does not run continuable dumps, the error remains and system operation may be affected. Default value is NO.

17 Press 'ENTER'. The Initial Program Load (IPL) screen will be displayed.

◆NEXT

9.8 UNPACKING AND SETUP

9.8 Software Installation

9.8.1 Initial Program Load (IPL) (Sheet 9 of 12)

```
*****
*
* WWWWW      WWWWW      A      NNN      NNN      GGGGGG
* WW         WW         AAAA   NNN      NN      GG   GG
* WW         WW         AA  AA  NN  N   NN      GG   GG
* WW      WW  WW      AA  AA  NN  N   NN      GG
* WW      WW  WW      AA  AA  NN  N   NN      GG   GGGG
* WW WWWWW WW      AAAA  AAAA  NN  N   NN      GG   GG
* WWWWW WWWWW      AA    AA  NN      NNN      GG   GG
*   WW   WW      AAA    AAA  NNN      NNN      GGGGGG
*
* *****
```

(c) Copyright Wang Laboratories, Inc. 1985

O.S. xx.xx.xx **System Generation In Progress** CP: xx.xx.xx

```

VVV  VVV      SSSSSS
VV   VV      SSS  SSS
VV   VV      SSS
VV   VV      SSSSS
VV   VV      SSSSS
VV  VV      SSS
VVVV  VVV  SSS  SSS
VV      SSSSSS
```

- 18** The message 'System Generation In Progress' will be displayed in the center of the screen. In about one minute, the Time and Date Screen will be displayed.

➡ NEXT

9.8 UNPACKING AND SETUP

9.8 Software Installation

9.8.1 Initial Program Load (IPL) (Sheet 10 of 12)

*** MESSAGE WN3 BY IPL

INFORMATION REQUIRED BY PROGRAM @SYSGEN@

SET DATE AND TIME

YEAR	YY	MONTH	MM	DAY	DD
HOUR	HH	MINUTE	MM	SECOND	SS

Memory Size 02048 K

- 19** Enter the date in the YY MM DD format.
Enter the current time using the 24-hour clock format. Press ENTER.

- 20** System initialization will begin. The screen will display the message:

System Initialization In Progress

- 21** When system initialization is completed successfully (about one minute), the Operator's console screen will be displayed.

➡ NEXT

9.8 UNPACKING AND SETUP

9.8 Software Installation

9.8.1 Initial Program Load (IPL) (Sheet 11 of 12)

* * * Wang VS Operator's Console * * *

10:12 AM Monday August 03, 1987

Position to (*) and Press (ENTER) to Provide Immediate Operator Service:

*MSG from QVR: Queue Verification Routine Complete 10:12

Press (1) to Return to User Mode

-or-

Use the Function Keys to Manage:

- | | |
|--------------------------|------------------------|
| 2) PRINT Queue | 9) PRINTERS |
| 3) PROCEDURE Queue | 10) DISKS |
| 4) TRANSMIT Queue | 11) TAPES |
| 5) RETRIEVE Queue | 12) TELECOMMUNICATIONS |
| | 13) WORKSTATIONS |
| 6) INTERACTIVE Tasks | |
| 7) NON-INTERACTIVE Tasks | 14) SYSTEM Options |

Press (HELP) at Any Time to Return to the Operator Console Menu

22 When message 'Queue Verification Routine Complete' appears (about 20 to 30 seconds) acknowledge message by positioning the cursor next to the message and press RETURN

23 Press PF1 to enter user mode. The VS Logon Screen will be displayed

➡ NEXT

9.8 UNPACKING AND SETUP

9.8 Software Installation

9.8.1 Initial Program Load (IPL) (Sheet 12 of 12)

```
      * * * Wang VS Logon * * *  
Workstation 0          10:13 AM          Monday August 03 1987  
      Hello new user  
      Welcome to Wang VS  
  
Please identify yourself by supplying the following information  
  
      Your userid      _____  
      Your password  
  
and press (ENTER) to logon  
  
or press (PF11) to enter operator mode immediately
```

- 24** Enter the default three-letter user ID, CSG. No password is required. Press ENTER. The command processor screen will be displayed.

```
      * * * WANG VS COMMAND PROCESSOR * * *  
Workstation 0 Ready   10:15 AM          Monday August 03, 1987  
      Hello  
      Welcome to Wang VS  
  
Press (HELP) at any time to interrupt your program or to stop  
processing of current command.  
  
Use function keys to select a command:  
  
(1) RUN Program or Procedure          (11) Enter OPERATOR Mode  
(2) Set USAGE Constraints              (12) Submit PROCEDURE  
(3) Show PROGRAM Completion Report  
  
(4) Manage QUEUES                     (13) Send MESSAGE to Operator  
(5) Manage FILES/Libraries            (15) PRINT Command Screen  
(6) Manage DEVICES                    (16) LOGOFF
```

- 25** Run GENEDIT (► 9.8.2) and configure the system.

• END

9.8 UNPACKING AND SETUP

9.8 Software Installation

9.8.2 System Generation (GENEDIT) Procedures (Sheet 1 of 7)

NOTE

This manual only contains 'GENEDIT' information that differs from other VS mainframes. For information pertaining to programs and features, refer to the 'VS-75E Processor Handbook'.

- 2 The RUN Program Screen will be displayed. Enter 'GENEDIT' next to the 'PROGRAM' prompt and leave the other fields blank. Press 'ENTER' to accept the entry. The GENEDIT 'Select CONFIG File Screen' will be displayed.

- 1 From Command Processor, select RUN Program or Procedure (PF1).

```
* * *WANG VS COMMAND PROCESSOR* * *
Copyright, Wang Laboratories, INC. 1985
Workstation 0 Ready      10:15AM      Monday August 03, 1987
```

```
      Hello
      Welcome to the Wang VS
```

```
      Press (HELP) at any time to interrupt your program or to stop
      processing of current command.
```

```
      Use function keys to select a command:
```

- | | |
|------------------------------------|-------------------------------|
| (1) RUN Program or Procedure | (11) Enter OPERATOR Mode |
| (2) Set USAGE Constraints | (12) Submit PROCEDURE |
| (3) Show PROGRAM Completion Report | (13) Send MESSAGE to Operator |
| (4) Manage QUEUES | (15) PRINT Command Screen |
| (5) Manage FILES/Libraries | (16) LOGOFF |
| (6) Manage DEVICES | |

➡ NEXT

9.8 UNPACKING AND SETUP

9.8 Software Installation

9.8.2 System Generation (GENEDIT) Procedures (Sheet 2 of 7)

GENEDIT x.xx.xx Copyright, Wang Laboratories, Inc.1985 Select CONFIG File
This program is used to create or modify a system configuration (CONFIG) file.

To edit an old CONFIG file, enter the file, library and volume:
VOLUME: SCSI1 LIBRARY: @SYSTEM@ FILE:

-or-

To create a new CONFIG file, enter the VS model number:

To upgrade the CONFIG File to a higher VS model, enter the CONFIG file name and the higher VS model number.

Press (32) from any screen to exit GENEDIT.

PRESS: (ENTER) to continue (9) to see list of Model Numbers
(16) to exit GENEDIT

- 3 Enter the VS model number in the 'To create a new CONFIG file, enter the VS model number: ' field to create a new CONFIG file. Press ENTER.
- 4 The GENEDIT Initialization screen will be displayed. In about 30 seconds the GENEDIT Main Menu screen will be displayed.

►NEXT

9.8 UNPACKING AND SETUP

9.8 Software Installation

9.8.2 System Generation (GENEDIT) Procedures (Sheet 3 of 7)

GENEDIT

Main Menu

Model VS

Select the function you wish to perform by pressing the corresponding PFKey:

- (2) Examine/Modify System Options
- (3) Examine/Modify the DA and Device Configurations
- (4) Display summary and Save/Create/Print the modified CONFIG File

Press: (16) to edit a new CONFIG File
(32) to Exit GENEDIT

- 5** Press PF3 to Examine/Modify the DA and Device Configurations. The VS Device Adapter Screen will be displayed.

GENEDIT

VS Device Adapters
Model VS

Jumper Address	PDA	1st Dev	DA Type	DA Description
000	2800	0	28V01	BP/SIO Device Adapt
000	2000	32	28V02	BP/Floppy DA
000	2010	33	28V03	BP/RS232 Async DA
000	2020	35	28V04	BP/SCSI DA
300	2000			
500	3000			
100	3400	40	25V50	Disk Device Adapter
600	3800			
400	3000			

TAB to Device Type and PRESS:

- (ENTER) to edit the devices on the Device Adapter
- (9) to show valid Device Adapters for the slot

or PRESS: (13) to modify the Device Adapter types;
(14) to modify the starting device numbers;
(16) to return to main menu

➡ NEXT

9.8 UNPACKING AND SETUP

9.8 Software Installation

9.8.2 System Generation (GENEDIT) Procedures (Sheet 4 of 7)

- 6 The Bus Processor (jumper address 0000) has four Physical Device Addresses (PDA) assigned to it. PDA 2800 contains the BP/SIO Device adapter, PDA 2000 contains the BP/Floppy DA, PDA 2010 contains the RS232 Async DA, and PDA 2020 contains the SCSI DA. Each DA is described in the following text with exception of the RS232 Async DA.

- 7 Tab to 28V01 BP/SIO Device Adapter and press ENTER to display the Devices on IOP screen. **The first device (Device 0, Port 0) must be a serial workstation, enter the appropriate workstation model number.**

NOTE

If a device other than a serial workstation is entered, the message 'Device 0 must be a workstation' will be displayed.

▶NEXT

9.8 UNPACKING AND SETUP

9.8 Software Installation

9.8.2 System Generation (GENEDIT) Procedures (Sheet 5 of 7)

GENEDIT

Devices on IOP
Model VS

Dev#	28V01 Port#	BP/SIO Device Type	Adapter IOP#2 Description	WP?
0	0	2256C	Combined WS (64K)	
1	1			
2	2			
3	3			
4	4			
5	5			
6	6			
7	7			
8	8			
9	9			
10	10			
11	11			
12	12			
13	13			
14	14			
15	15			

TAB to Device Type and PRESS:
(ENTER) Reserve cluster devices
(12) Shift

or PRESS: (5) Next
(9) Valid Devices (16) Return
(13) Modify (▲1) Main Menu

8 Press PF16 to return to the VS Device Adapters Screen.

9 Select 28V02 BP/Floppy DA and press 'ENTER'. Enter the drive type 2270V7 (1.2 MB) and press ENTER. Press PF16 to return to the VS Device Adapter Screen.

GENEDIT

Disks on DA
Model VS

Dev#	28V02 Port#	BP/Floppy DA Type	IOP#2 Description	Attach?
33	0	2270V7	1.2MB 5-1/4" Floppy	

TAB to Device Type and PRESS:
(12) Shift Devices Up/Down

or PRESS: (5) Next
(9) Valid Disk (16) Return
(13) Modify (▲1) Main Menu

➡ NEXT

9.8 UNPACKING AND SETUP

9.8 Software Installation

9.8.2 System Generation (GENEDIT) Procedures (Sheet 6 of 7)

- 10 Select 28V04 BP/SCSI DA and press ENTER. The Disks on DA screen will be displayed.

```
GENEDIT                                     Disks on DA
                                           Model VS 
28V04      BP/SCSI DA      IOP#3
Dev#      Port#      Type      Description      Attach?
-----
35      6      2269V4      145MB SCSI Fixed Dk
36        6
37        6
38        6
39      5      2269V4      145MB SCSI Fixed Dk
40        5
41        5
42        5
43        4
44        4
45        4
46        4
47        3
48        3
49        3
50        3

TAB to a device and PRESS:      or PRESS:
(12) Shift devices up/down      (9) Valid Disk      (16) Return
                                  (13) Modify         (▲1) Main Menu
```

NOTE

Only one SCSI disk drive device type can be assigned per port. If a second SCSI disk drive is assigned, the message 'The device specified is not a cluster device, it requires a unique part number' will be displayed.

➡NEXT

9.8 UNPACKING AND SETUP

9.8 Software Installation

9.8.2 System Generation (GENEDIT) Procedures (Sheet 7 of 7)

- 11 The SCSI drive that contains IPL Bootfiles must be assigned to port 6. Additional SCSI drives may be assigned to either port 5, 4, or 3.
- 12 Configure the SCSI disk drives and press ENTER. Press PF16 to return to the VS Device Adapters Screen.
- 13 Complete Device Adapters system configuration.

● END

9.9 UNPACKING AND SETUP

Stand-Alone Utilities (SAU)

The Stand Alone Utility (SAU) is a VS utility that runs independently of the VS operating system. The SAU is a self-contained, stand alone program that does not use the normal operating system nor can the operating system use the SAU program.

The SAU is used to initially load the VS operating system onto the system disk. The SAU utility is contained on one 1.2MB floppy diskette labeled SAUDK1.

The primary purpose of the SAU is to format the system disk and copy the operating system software to it during system installation. This utility can also be used for system disk maintenance such as initializing, reformatting and preparing a new system disk.

● END

9.9 UNPACKING AND SETUP

9.9.1 Stand-Alone Utilities (SAU)

9.9.1 Copy Utility

SAU allows the user to copy data from an input diskette or tape into the current system volume. Three levels of the copy utility are supported and are defined as follows:

- **Initialize**

Formats a new system volume, analyzes the disk surface for reliable data storage, constructs the Volume Table Of Contents (VTOC), creates a volume label and copies data. This option overwrites the system disk.

- **Reformat**

Constructs the Volume Table Of Contents, creates a volume label and copies the data. This option overwrites the system disk.

- **Copy Only**

Copies the files needed to update the system volume without initializing or reformatting the system volume.

When running SAU, select the copy function required depending on the situation of the mainframe. Consider the following:

- For a new system, the disk must be initialized for system volume, use the Initialize option.
- If the system volume has already been initialized, use the Reformat option. Reformat clears and rewrites the VTOC.
- To load new system files without rebuilding the entire system, use the Copy option. Copy option checks for duplicate file names, flags them, and allows the user the option to skip the input file or to rename either the old file or the new file to make copying possible.

● END

9.9 UNPACKING AND SETUP

9.9.9 Stand-Alone Utilities (SAU)

9.9.2 Loading SAU

This section describes the steps required to load the SAU program. After the bootstrap SAUDK1 diskette has loaded system microcode into main memory, load operating system software onto the system disk from either diskettes or tapes. When procedure is completed, IPL from the newly formatted system volume.

- 1 Ensure the system has powered up successfully. (▶4.1)
- 2 Position the front panel keyswitch in the 'Local' position.
- 3 Insert SAUDK1 diskette into the floppy drive and latch the door closed.

- 4 Position Boot Device Switch to 'Floppy' position.
- 5 Press Control Mode pushbutton switch, then press the Initialize pushbutton switch.

NOTE

BIT diagnostics test automatically run after the Initialize switch is pressed. The Hex display counts down from FFFF to 0000. The Hex display then counts up through a series of diagnostic routines and finally blanks.

- 6 The following message appears on the WSO:

Loading System Microcode

Loading Complete, Beginning System Initialization

- 7 System microcode and SAU program are now loaded into memory.

● END

9.9 UNPACKING AND SETUP

9.9.3 Stand-Alone Utilities (SAU)

9.9.3 Running SAU (Sheet 1 of 9)

Once the SAU has finished loading, the SAU Function Screen appears.

Stand-Alone Utility - Version x.xx.x Select Function
(c) Copyright 1987, Wang Laboratories, Inc.

SAU is designed as a means of installing the initial software required for operation with this CPU

Press PF4 to initiate the installation
Press PF5 to create the installation media
Press PF6 to relabel the system volume

- 1 Press PF4 to initiate installation. The Define Input Device Screen will be displayed.

Stand-Alone Utility - Version x.xx.x Define Input Device
(c) Copyright 1987, Wang Laboratories, Inc.

Please enter the device type and address of the input device.

Device Type -
Physical Device Address (PDA) -

Device Type	PDA	Description	Volume	Status
2270V7	2000	1.2MB 5-1/4" Floppy	SAUDK1	Standard Label
2238V1	2801	Streamer Cart Tape		
2529V	2802	6400bpi Cartridge Tp		

Press (ENTER) to continue

➡ NEXT

9.9 UNPACKING AND SETUP

9.9.3 Stand-Alone Utilities (SAU)

9.9.3 Running SAU (Sheet 2 of 9)

- The Define Input Device screen prompts the user to specify the device type and PDA (physical device address) for the input device used to load SAU. It also shows the input devices allowed for this procedure. Enter the device type and the PDA number of device used and press (ENTER). The Define System Device screen appears.

Stand-Alone Utility - Version x.xx.x
(c) Copyright 1987, Wang Laboratories, Inc.

Define System Device

Please enter the device type and address of the output device.

Device Type -
Physical Device Address (PDA) -

Device Type	PDA	Description	Volume	Status
2269V4	2020	145MB 5-1/4" fix disk	SCSI0	Standard Label
2269V4	2021	145MB 5-1/4" fix disk	SCSI1	Standard Label

Press (ENTER) to continue

- This screen prompts the user to specify the system device type and PDA for the disk that will be used as the system disk. It also contains the devices for the system that can be designated as system disks. Enter the system device type and PDA and press (ENTER). The Specify Label Handling screen appears.

▶NEXT

9.9 UNPACKING AND SETUP

9.9.3 Stand-Alone Utilities (SAU)

9.9.3 Running SAU (Sheet 3 of 9)

Stand-Alone Utility - Version x.xx.x
(c) Copyright 1987, Wang Laboratories, Inc.

Specify Label Handling

Press (PF2) to INITIALIZE the system disk
Press (PF3) to REFORMAT the system disk
Press (PF4) to COPY only.

Or Press (PF1) to return.

- 4 Press the PF key that corresponds to the operation to be performed. Refer to the following table for SAU operating description.

SAU Operations

<i>Utility</i>	<i>Description</i>
Initialize	Formats and verifies system disk, constructs Volume Table of Contents (VTOC), creates a volume label, and copies the data. This option overwrites the system disk. All data on the disk is lost.
Reformat	Constructs the VTOC, creates a volume label and copies the data. This option overwrites the system disk. All data on the disk is lost.
Copy	Copies files to the system volume output without initializing or reformatting it.

►NEXT

9.9 UNPACKING AND SETUP

9.9.3 Running SAU (Sheet 4 of 9)

- Pressing PF4 COPY, the SAU 'Request to Mount' screen appears with the message 'Please mount first diskette'. This message appears whether the input medium is a removable disk or diskette. If COPY is selected go to step 12.
- Pressing PF2 INITIALIZE or PF3 REFORMAT, the Specify Volume Label Screen appears (refer to Volume Label Parameters table).

Stand-Alone Utility - Version x.xx.x
(c) Copyright 1987, Wang Laboratories, Inc.

Specify Volume Label

System Disk

The following information is required for volume formatting:

Volume Name	-	SYSTEM	
Volume Owner	-	██████████	
Date (MM/DD/YY)	-	██ / ██ / ██	
VTOC Size (in blocks)	-	0252	
Fault tolerance	-	NONE	(NONE - No fault tolerance)
			(CRASH - Tolerate system halt)
			(Media - Tolerate bad media also)
Extent limit at file creation	-	003	
Total allowable extends	-	013	

Please supply the required parameters and press (ENTER) to continue, or press (PF1) to return.

- This screen prompts the user to specify information that is used by the SAU to create the system disk volume label. (▶ Volume Label Parameter table).

▶NEXT

9.9 UNPACKING AND SETUP

9.9.9 Stand-Alone Utilities (SAU)

9.9.3 Running SAU (Sheet 5 of 9)

Volume Label Parameters Table

<i>Parameter</i>	<i>Entry</i>
Volume Name	Enter a unique name for the system volume.
Volume Owner	Enter the name of the owner of the volume. For a disk, the volume owner can be from 1 to 14 characters long. For a tape, the volume owner can be from 1 to 3 characters long.
Date	Enter the current date using the MM/DD/YY format.
VTOC Size	Enter the number of blocks that you want to allocate as default for VTOC. For the VS-75E you can enter 0252. The default varies with disk size. This default can be overridden if expected to make an unusually large number of entries into VTOC. For example, you should enlarge the size of VTOC if many small files are to be created on the volume. Refer to 'VS System Utilities Reference Addendum' for information on VTOC size.
Fault Tolerance	Enter the type of tolerance you want. Select from NONE, CRASH, and MEDIA. Your selection in the fault tolerance category affects the amount of disk space that remains. Choosing NONE allocated the most memory with the least protection. MEDIA allocated the least memory the most protection. Refer to 'VS System Utilities Reference Addendum' for information on VTOC size.
Extended Limit at file creation	Enter the number of blocks for the extent limit at file creation (3 - 255). The default value is 3 extents. Before setting higher limits, consider the volume's media condition. Refer to the appropriate VS Software Bulletins for additional information.
Total Allowable Extends	Enter the number of blocks for the total number of extends allowed. The default limit is 13. Before setting higher limits, consider the volume's media condition. (Default of 13 extends is recommended for initial system installation.) Refer to the appropriate VS Software Bulletin for additional information.

➡NEXT

9.9 UNPACKING AND SETUP

9.9.9 Stand-Alone Utilities (SAU)

9.9.3 Running SAU (Sheet 6 of 9)

- 8 Enter the information on the SAU Volume Label Specification screen and press [ENTER]. The Formatting Screen appears and displays the message:

Disk formatting in progress

The SAU can initialize one 2269V4 (145MB) drive in approximately 3 hours. Once completed, the SAU Allocate Dump or Page Filing screen is displayed.

Stand-Alone Utility - Version x.xx.x
(c) Copyright 1987, Wang Laboratories, Inc.

Allocate Dump or Paging Files

Please specify the size of pre-allocated control mode dump file. The size of the file should correspond to the size of main memory for any CPU you intend to use this disk on. Enter a size of zero (0) if you do not want to allocate a dump file at this time.

Size of pre-allocated dump file = 00000 K

Please specify the size and location of the user paging pool. The size of the pool should be based on the number of tasks and their segment 2 sizes which may use this disk for paging. Enter a zero (0) if you do not want to allocate a paging pool at this time.

Size of paging pool = 00000 K

Pool location (relative to VTOC) = 0

0 = nearest VTOC
9 = farthest from VTOC

Press [ENTER] to continue.

►NEXT

9.9 UNPACKING AND SETUP

9.9.3 Running SAU (Sheet 7 of 9)

9 This screen prompts you to specify appropriate VTOC information for the system disk volume label. Enter the information or select the default values and press (ENTER).

10 The 'SAU Request to Mount' screen is displayed. The following message is displayed:

Tape Input:

For a tape input medium, power up the tape drive. Insert or mount the system files tape after the message 'Mount the first tape' appears. Press the ON-LINE button.

After several seconds, if the load is successful, the TAPE LOADED indicator will illuminate. The system rewinds the tape and displays the message 'Copy in progress'.

Please mount the first diskette

11 Remove the SAUDK1 diskette from the floppy drive.

12 Copy the input files onto the system disk. This can be accomplished either by diskettes or tape. Perform the following which applies:

Diskette:

For a diskette input medium, insert the diskette labeled 'SYST01' or an updated diskette into the diskette drive and latch the door closed. The system will begin copying the files.

◆NEXT

9.9 UNPACKING AND SETUP

9.9.3 Stand-Alone Utilities (SAU)

9.9.3 Running SAU (Sheet 8 of 9)

- 13** If a Copy-Only operation is being performed using either diskette or tape media, and the SAU encounters a duplicate file, copying stops and the Duplicate File Name screen appears.

Stand-Alone Utility - Version x.xx.x
(c) Copyright 1987, Wang Laboratories, Inc.

Duplicate File Name

A file with the name **@SYS000@** already exists in **@SYSTEM@**

Press

PF1 to skip copying file, or
PF2 to copy the renamed input file, or
PF3 to rename old file/copy new file

- 14** To rename a file, place the cursor under the highlighted file name. Re-enter the modifiable file name. Press the appropriate PF key to indicate the Duplicate File Name option selected. 'Copy in Progress' prompt will be displayed.
- 15** If the system files are contained on more than one diskette or tape, the following prompts will be displayed:

➡NEXT

9.9 UNPACKING AND SETUP

9.9.3 Stand-Alone Utilities (SAU)

9.9.3 Running SAU (Sheet 9 of 9)

Diskette:

The message 'Please Mount the next diskette: xxxxxx' is displayed, where 'xxxxxx' is the name of the next input diskette. Remove the diskette from the floppy drive and insert the second diskette. Follow the screen prompts until all diskettes are copied.

Tape:

The message 'Please Mount the next tape: xxxxxx' is displayed, where 'xxxxxx' is the name of the next input tape. The system rewinds the tape automatically. Remove the tape from the tape drive and insert the second tape. Follow the screen prompts until all tapes are copied.

- 16 When all tapes and diskettes are copied, the message 'Initialization Completed. IPL when ready' is displayed. Remove the diskette or tape.

NOTE

After copying operating system files to a new system volume, SAU Relabel function must be performed before IPLing from the new system volume.

● END

9.9 UNPACKING AND SETUP

9.9.9 Stand-Alone Utilities (SAU)

9.9.4 SAU Relabel Procedures (Sheet 1 of 2)

- 1 Press PF1 to return to the SAU Select Screen.

```
Stand-Alone Utility - Version x.xx.x                               Select Function
(c) Copyright 1987, Wang Laboratories, Inc.
```

SAU is designed as a means of installing the initial software required for operation with this CPU

Press PF4 to initiate the installation
Press PF5 to create the installation media
Press PF6 to relabel the system volume

- 2 Press PF6 to select Relabel System Volume. The SAU Select Relabel Volume screen will be displayed. This screen prompts you to enter the label and PDA of the volume to be relabeled and displays a list of volumes in the installation.

```
Stand-Alone Utility - Version x.xx.x                               Select Relabel Volume
(c) Copyright 1987, Wang Laboratories, Inc.
```

Please enter the volume label and address of the device

Volume Label -
Physical Device Address (PDA) -

Device Type	PDA	Description	Volume	Status
2270V7	2000	1.2MB 5-1/4" Fioppy	SAUDK1	Standard Label
2269V4	2020	145MB SCSI Fixed Dk	SYSTEM	Standard Label
2269V4	2020	145MB SCSI Fixed Dk	DATA	Standard Label

Press [ENTER] to continue or [PF1] to return.

➡ NEXT

9.9 UNPACKING AND SETUP

9.9.9 Stand-Alone Utilities (SAU)

9.9.4 SAU Relabel Procedures (Sheet 2 of 2)

- 3 Enter the volume label and PDA, and press ENTER. The SAU Rename Volume screen appears with the current volume name selected.

```
Stand-Alone Utility - Version x.xx.x
(c) Copyright 1987, Wang Laboratories, Inc.
```

```
Please Rename the Volume
```

```
Volume: SCSI02
```

```
Press (ENTER) to continue or (PF1) to return.
```

- 4 Enter the new volume name by overstriking the current name and press ENTER. The SAU Display Message screen will be displayed. Note if the System volume was renamed, the message '@MCBOOT pointer in VOL1 was also updated' will also be displayed.

```
Stand-Alone Utility - Version x.xx.x
(c) Copyright 1987, Wang Laboratories, Inc.
```

```
Relabel process successfully completed
With new LABEL: SCSI1
At PDA: 2021
(@MCBOOT pointer in VOL1 was also updated)
```

- 5 Re-IPL the system from the new system volume just created (►4.1).

● END

UNPACKING AND SETUP

9.10 Remote System Administrator Facility (RSAF)

Remote Maintenance (RSAF) is an option that allows the customer to contact and run a remote maintenance session, via the telephone line, with the Remote Maintenance Center to isolate possible system problems. Refer to the VS Remote System Administrator Facility (RSAF) manual part number 742-1657 for information on hardware installation and system interconnection.

● END

UNPACKING AND SETUP

9.11 Option Board Upgrade Installation

This section contains information on option PCB installation and cabling requirements. Each option installation includes a list of items the option contains and an interconnection diagram (schematic representation) for option cabling. Items and procedures unique to any given option are addressed.

● END

9.11 UNPACKING AND SETUP

9.11.1 Option Board Upgrade Installation

9.11.1 Async Option (25V36) Installation (Sheet 1 of 2)

The Async Option provides eight RS232 serial ports for peripheral connections. This option contains:

- 210-9355 Async Device Controller PCA.
- 272-0048 Async Back Panel
- 220-3542 40 Pos Soc-Soc Cable (2 ea.)
- 220-3543 40 Pos Soc-Soc Cable (2 ea.)

PCB Installation

- 1 Power-off the VS-75E and disconnect ac power. (➡4.2)
- 2 Remove top cover. (➡7.2.1)
- 3 Remove PCB Hold Down device. (➡7.2.4)
- 4 Set the Async Device Controller address to 0600 (or any available address). (➡7.2.15)

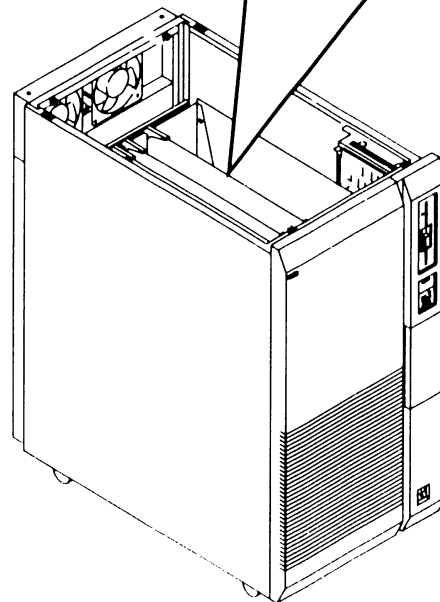
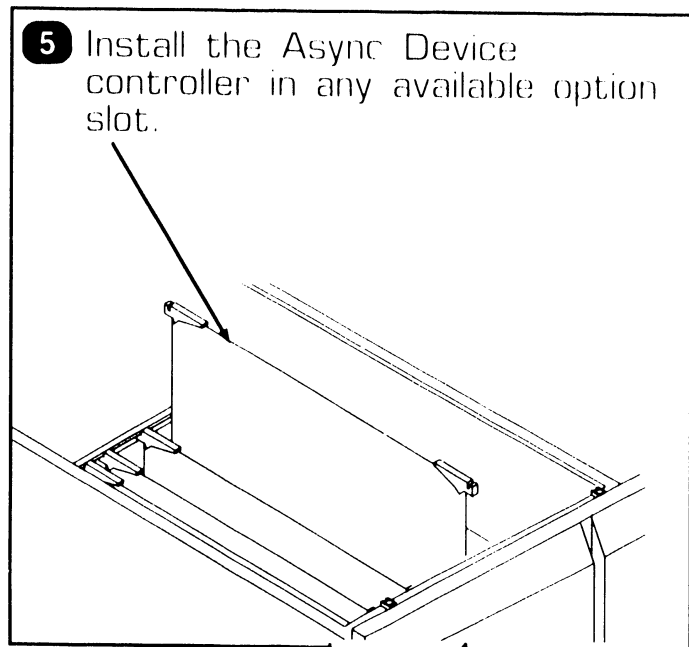

➡NEXT

9.11 UNPACKING AND SETUP

Option Board Upgrade Installation

9.11.1 Async Option (25V36) Installation (Sheet 2 of 2)

Async Back Panel Installation

- 1 Remove two adjacent blank I/O panels from rear panel assembly (►7.2.23).

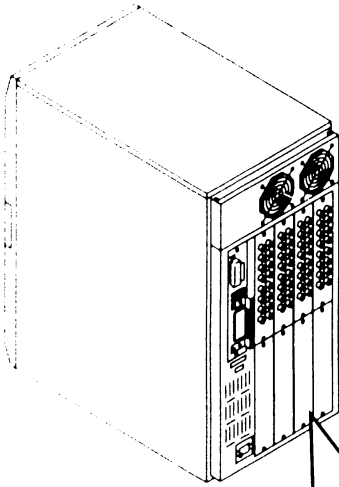

- 2 Install Async half-panel in space vacated by blank I/O panels.

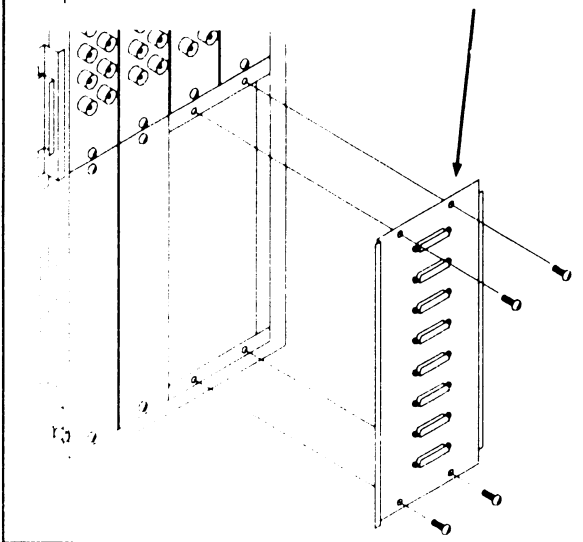

Async Controller/Half-Panel Cabling

- 1 Install the RS232 cables through the mainframe and connect cables to the Async Device Controller PCA and Async Bank Panel as shown.

ASYNC PCA
210-9355-A

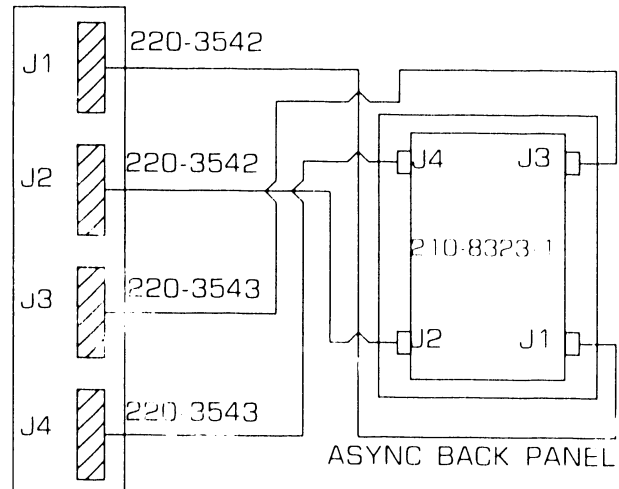

MOTHERBOARD
OPTION SLOT

ASYNC BACK PANEL

● END

9.11 UNPACKING AND SETUP

Option Board Upgrade Installation

9.11.2 1-Port TC DA Option (25V76-1) Installation (Sheet 1 of 3)

The 1-Port TC DA Option provides serial communications ports (X.21, RS232, RS366, and RS449) for peripheral connections. This option contains:

- 210-9337-A TC DA PCB
- 272-0051 Single Port TC Panel
- 210-7785-A PCB Light Board
- 210-3556 Cable, TC PCB J4 to Light Board PCB J1
- 220-3539 Cable, RS232/RS366 (2 ea.)
- 220-3541 Cable, X.21 (1 ea.)
- 615-3023 Label, Telecommunications

PCB Installation

- 1** Power-off the VS-75E and disconnect ac power. (▶4.2)
- 2** Remove top cover. (▶7.2.1)
- 3** Remove PCB Hold Down device. (▶7.2.4)
- 4** Set the 1-Port TC DA address to 0600 for the first TC DA, 0500 for the second TC DA, and 0300 for the third TC DA installed. (▶7.2.11)

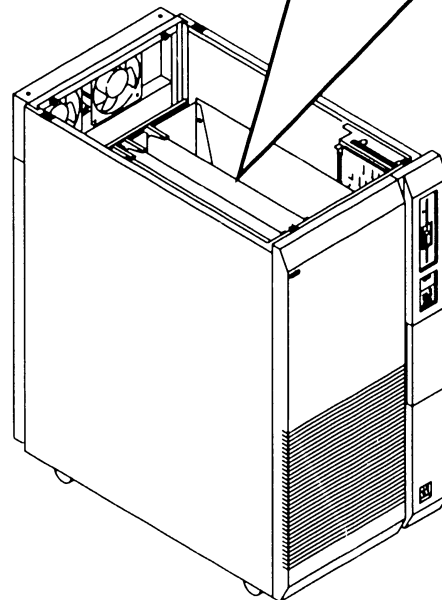
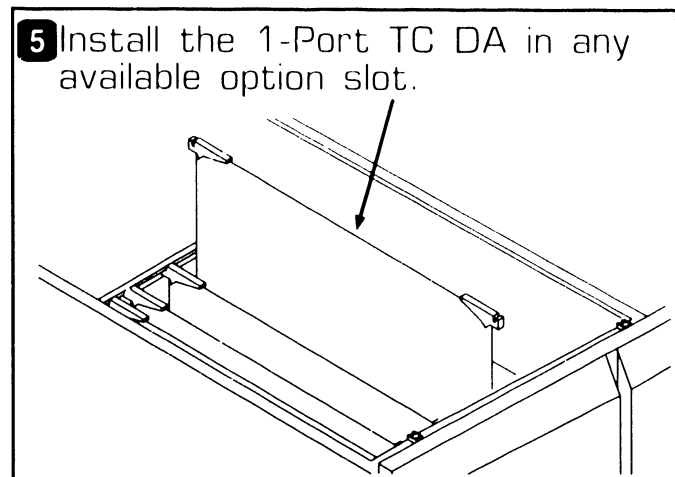

▶NEXT

9.11 UNPACKING AND SETUP

Option Board Upgrade Installation

9.11.2 1-Port TC DA Option (25V76-1) Installation (Sheet 2 of 3)

Single Port TC Panel Installation

- 1 Remove one blank I/O panel from rear panel assembly (➡7.2.23) for each 1-port TC DA installed.

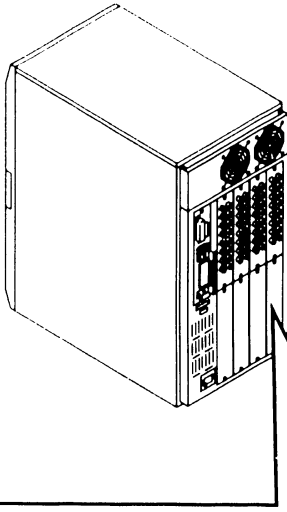

- 2 Install the Single Port TC Panel in the space vacated by blank I/O panel.

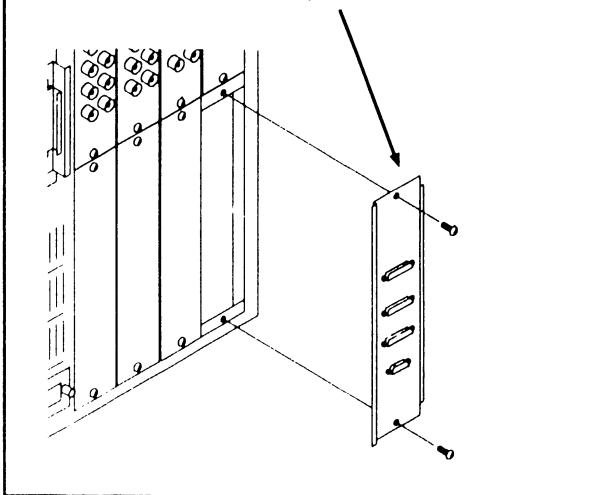

TC Light Panel Installation

- 1 Remove the TC blank panel from the location the light panel is to be located (➡7.2.21)
- 2 Install the TC Light Panel in the space vacated by blank panel.

➡NEXT

9.11 UNPACKING AND SETUP

Option Board Upgrade Installation

9.11.2 1-Port TC DA Option (25V76-1) Installation (Sheet 3 of 3)

1-Port TC Cabling

- 1 Install the RS232, RS366, and X.21 cables through the mainframe and connect the cables between the 1-Port TC DA and the 1-Port TC half-panel as shown.
- 2 Install the Light Board Interface Cable from 1-Port TC connector J4 to the Light Board PCA connector.

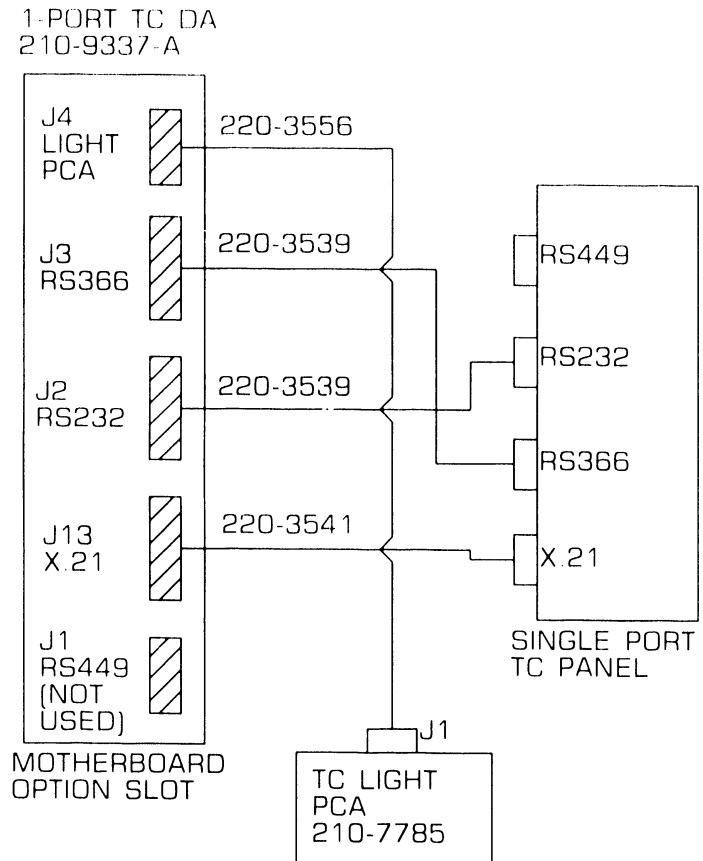

● END

9.11 UNPACKING AND SETUP

Option Board Upgrade Installation

9.11.3 2-Port TC DA Option (25V76-2) Installation (Sheet 1 of 3)

The 2-Port TC DA Option provides the user with serial communications ports (X.21, RS232, and RS366) for peripheral connections. This option contains:

- 210-9637-A 2-Port TC DA PCB
- 272-0052 Dual Port TC Panel
- 210-7785-A PCB Light Board (2 ea.)
- 220-3539 Cable, 2 ea., Ch1 RS232/366
- 220-3540 Cable, 2 ea., Ch2 RS232/366
- 220-3541 Cable, 2 ea., Ch1/2 X.21
- 615-3023 Label, TC (2 ea.)

PCB Installation

- 1 Power-off the VS-75E and disconnect ac power. (▶4.2)
- 2 Remove top cover. (▶7.2.1)
- 3 Remove PCB Hold Down device. (▶7.2.4)
- 4 Set the 2-Port TC DA address to 0600 for the first TC DA, 0500 for the second TC DA, and 0300 for the third TC DA installed. (▶7.2.11)

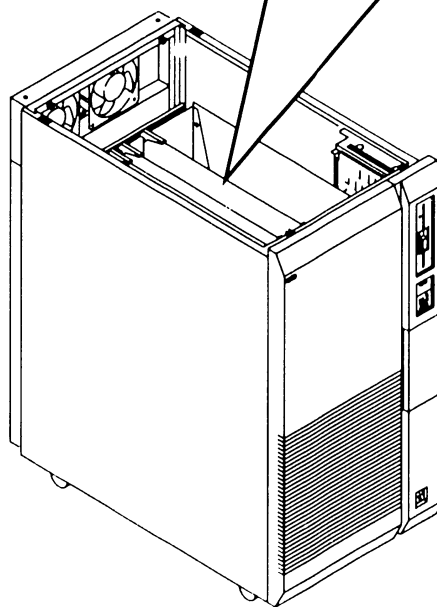
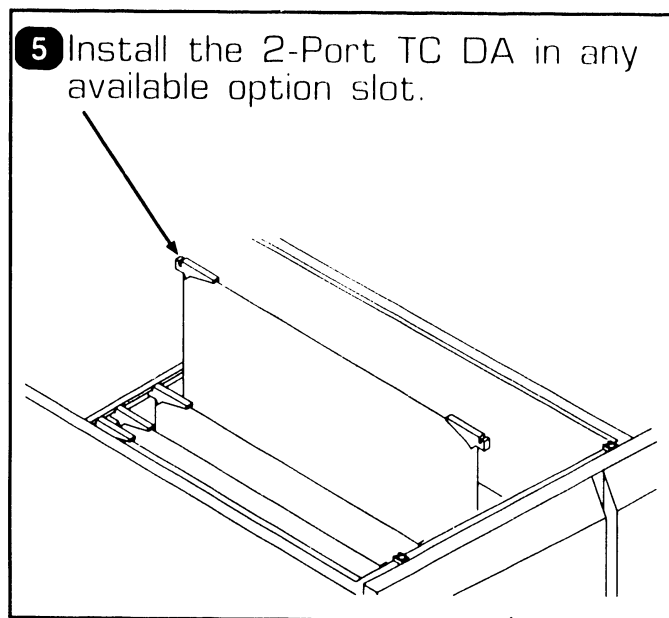

▶NEXT

9.11 UNPACKING AND SETUP

Option Board Upgrade Installation

9.11.3 2-Port TC DA Option (25V76-2) Installation (Sheet 2 of 3)

Dual Port TC Panel Installation

- 1 Remove one blank I/O panel from rear panel assembly (➡7.2.23) for each 2-port TC DA installed.

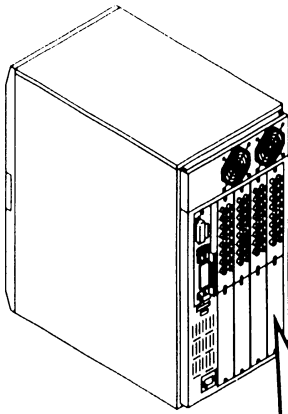

TC Light Panel Installation

- 1 Remove one blank TC panel from rear panel assembly (➡7.2.21) for each 1-port TC DA installed.
- 2 Install the TC Light Panel in the space vacated by blank I/O panel.

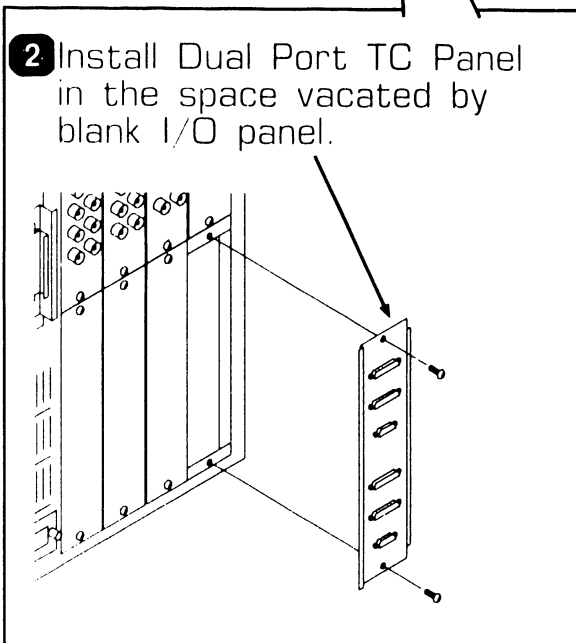

➡NEXT

9.11 UNPACKING AND SETUP

Option Board Upgrade Installation

9.11.3 2-Port TC DA Option (25V76-2) Installation (Sheet 3 of 3)

2-Port TC DA Cabling

- 1 Install the RS232, RS366, and X.21 cables through mainframe and connect the cables between the 2-Port TC DA and the Dual Port TC half-panel as shown.
- 2 Note cable orientation and install the Light Board Interface Cables from 2-Port TC connector S1 to the first Light Board PCB connector S1 to the first Light Board PCB connector and 2-Port TC connector S2 to the second Light Board PCB connector.

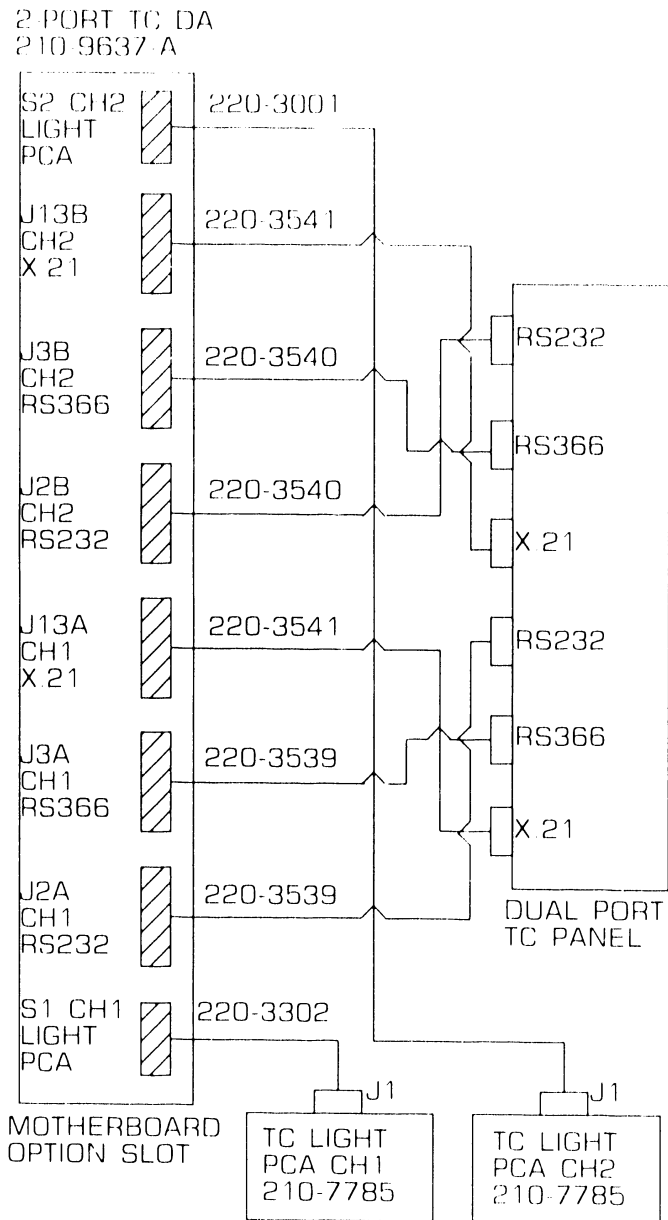

● END

9.11 UNPACKING AND SETUP

Option Board Upgrade Installation

9.11.4 2-Port SMD Option (25V50-2) Installation (Sheet 1 of 2)

The 2-Port SMD Option provides the user with two external ports. This option contains:

- 210-9313-A 2-Port SMD PCB
- 272-0054 SMD Panel
- 220-3544 'B' Cable, 2 ea., Drive 0/1
- 220-3546 'A' Cable, 2 ea., Drive Data

PCB Installation

- 1 Power-off the VS-75E and disconnect ac power. (➡4.2)
- 2 Remove top cover. (➡7.2.1)
- 3 Remove PCB Hold Down device. (➡7.2.4)
- 4 Set the 2-Port SMD address to 0100 for External drive or address 0200. Set the Drive-type switches for drive type installed. (➡7.2.8)

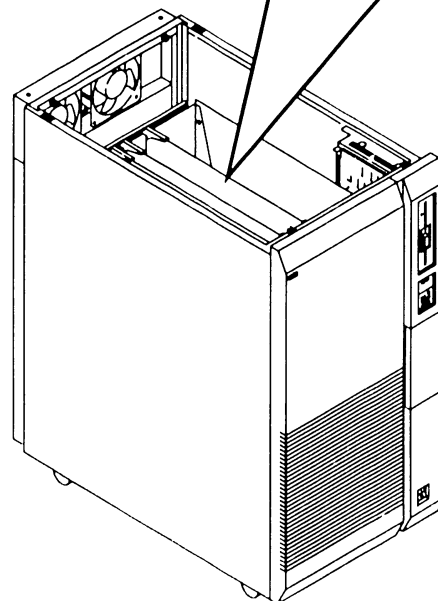
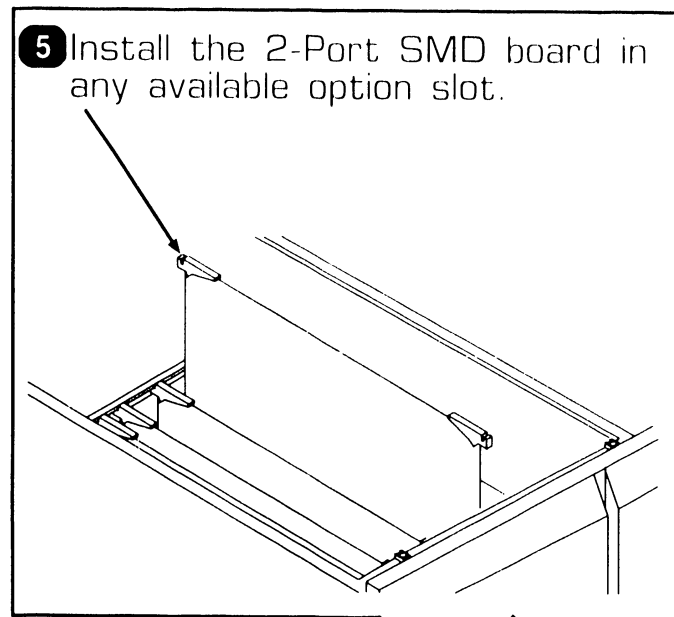

➡NEXT

9.11 UNPACKING AND SETUP

9.11.11 Option Board Upgrade Installation

9.11.4 2-Port SMD Option (25V50-2) Installation (Sheet 2 of 2)

SMD Panel Installation

- 1 Remove one blank I/O panel from rear panel assembly (7.2.23) for each SMD DA installed.

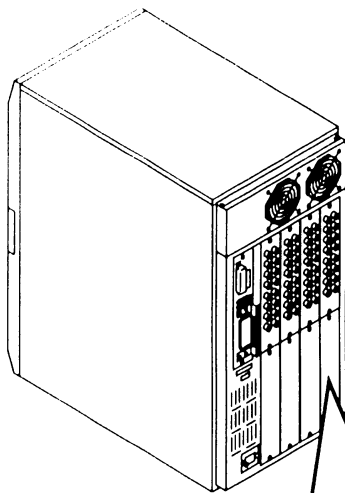

- 2 Install the SMD Panel in the space vacated by blank I/O panel.

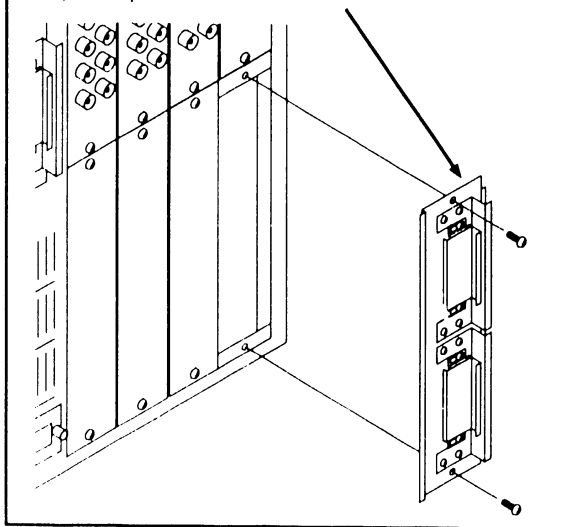

2-Port SMD Cabling

- 1 Install the 'A' and 'B' cables through the mainframe and connect the cables between the 2-Port SMD DA and the SMD Panel as shown.

2-PORT SMD PCA
210-9313-A

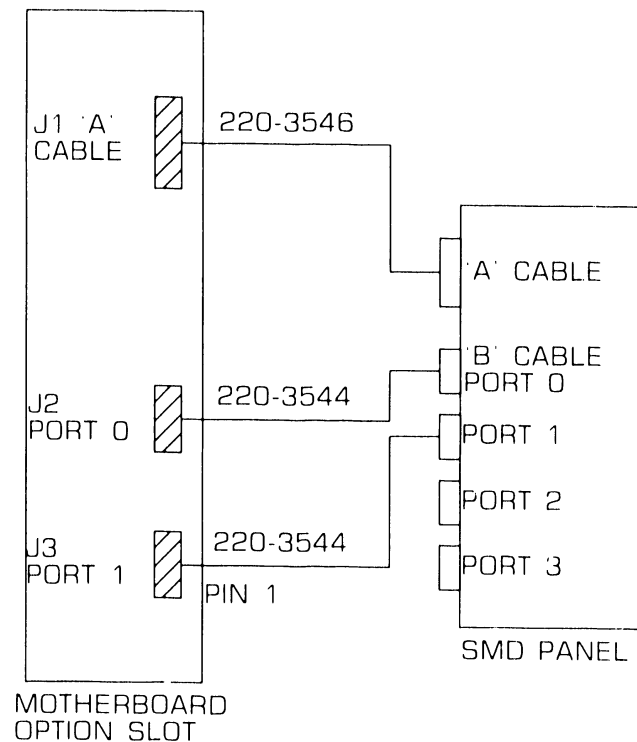

● END

9.11 UNPACKING AND SETUP

Option Board Upgrade Installation

9.11.5 4-Port SMD Option (25V50-4) Installation (Sheet 1 of 2)

The 4-Port SMD Option provides the user with four external drive ports. This option contains:

- 210-9315-A 4-Port SMD PCB
- 272-0054 SMD Half-Panel
- 220-3544 'B' Cable, 2 ea., Drive 0/1
- 220-3545 'B' Cable, 2 ea., Drive 2/3
- 220-3546 'A' Cable, Drive Data

PCB Installation

- 1 Power-off the VS-75E and disconnect ac power. (➡4.2)
- 2 Remove top cover. (➡7.2.1)
- 3 Remove PCB Hold Down device. (➡7.2.4)
- 4 Set the 4-Port SMD address to 0100 for External drive or address 0200. Set the Drive-type switches for drive type installed. (➡7.2.9)

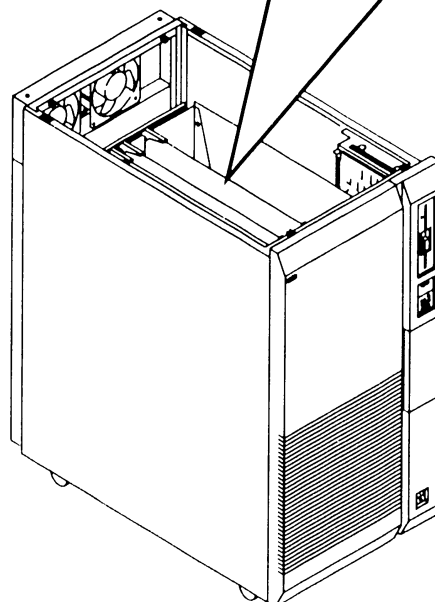
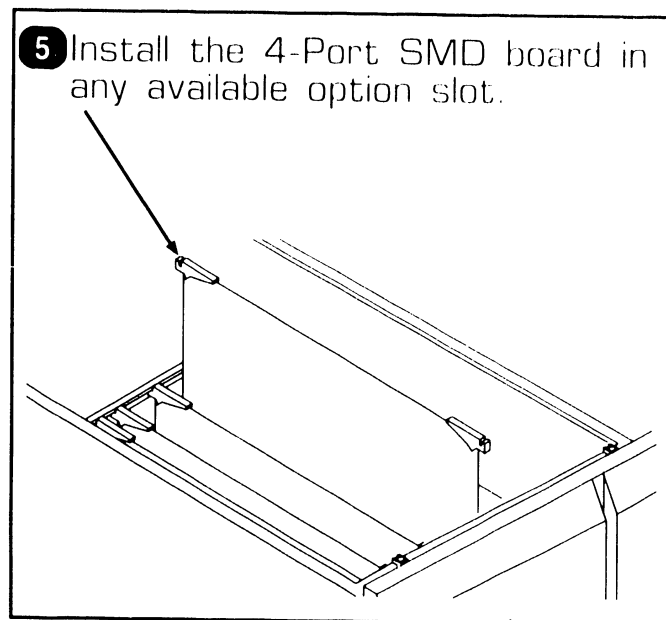

➡NEXT

9.11 UNPACKING AND SETUP

Option Board Upgrade Installation

9.11.5 4-Port SMD Option (25V50-4) Installation (Sheet 2 of 2)

SMD Panel Installation

- 1 Remove one blank I/O panel from rear panel assembly (► 7.2.23) for each 4-port SMD DA installed.

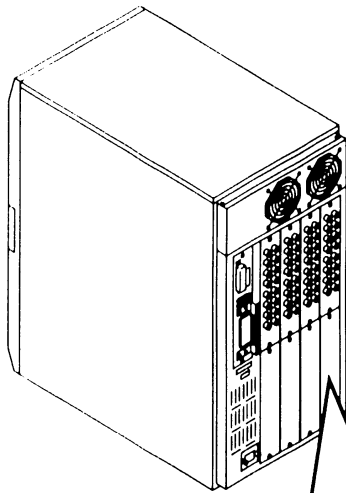

- 2 Install the SMD Panel in the space vacated by blank I/O panel.

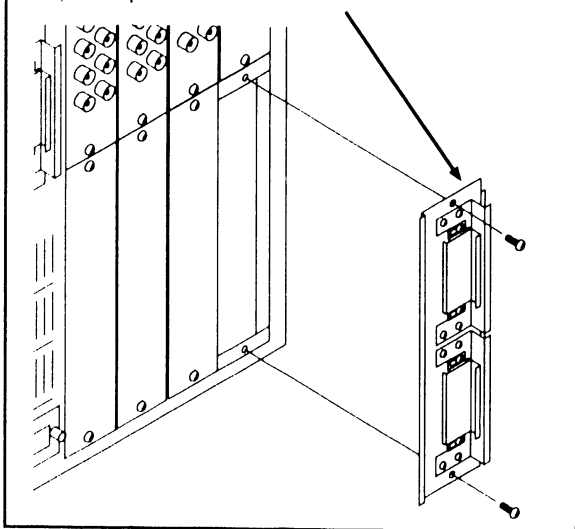

4-Port SMD Cabling

- 1 Install the 'A' Cable and 'B' cables through the mainframe and connect the cables between the 4-Port SMD and the SMD Panel as shown.

4-PORT SMD PCA
210-9315-A

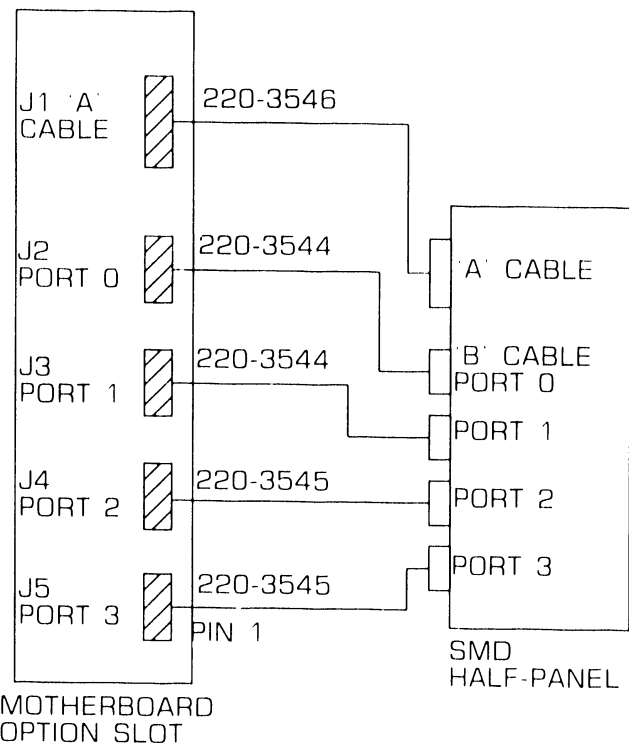

● END

9.11 UNPACKING AND SETUP

Option Board Upgrade Installation

9.11.6 High-Speed 4-Port SMD Option (25V98-4) Installation (Sheet 1 of 2)

The High Speed 4-Port SMD Option provides the user with four High-Speed external drive ports. This option contains:

- 210-9415-A High-Speed 4-Port SMD PCB
- 272-0054 SMD Half-Panel
- 220-3544 'B' Cable, 2 ea., Drive 0/1
- 220-3545 'B' Cable, 2 ea., Drive 2/3
- 220-3546 'A' Cable, Drive Data

PCB Installation

- 1 Power-off the VS-75E and disconnect ac power. (➡4.2)
- 2 Remove top cover. (➡7.2.1)
- 3 Remove PCB Hold Down device. (➡7.2.4)
- 4 Set the High-Speed 4-Port SMD address to 0100 for External drive or address 0200. Set the Drive-type switches for drive type installed. (➡7.2.10)

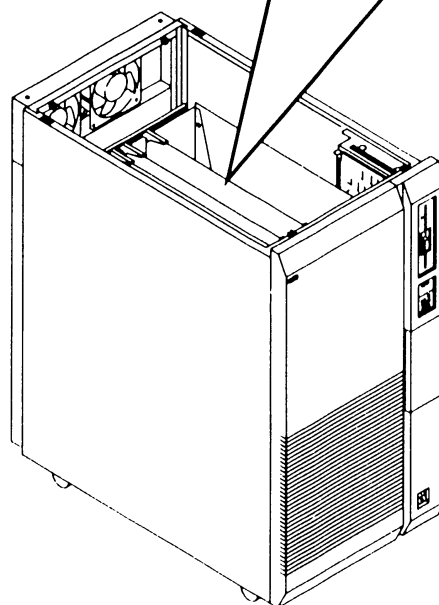
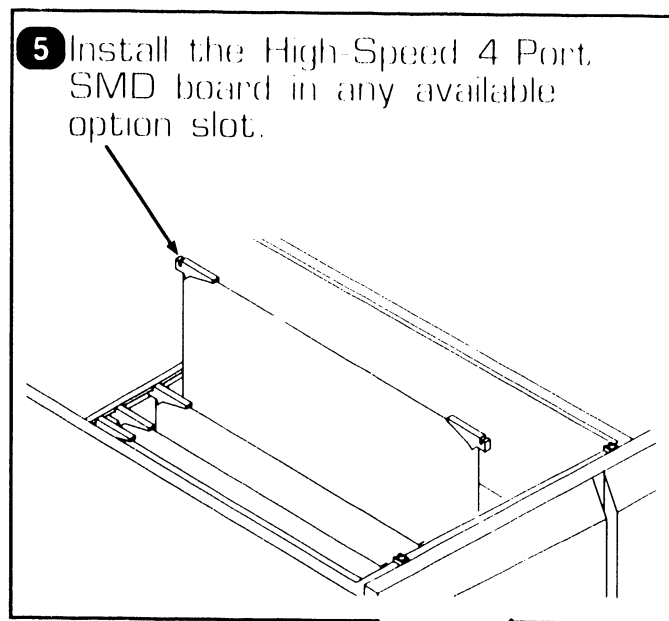

➡NEXT

9.11 UNPACKING AND SETUP

9.11.11 Option Board Upgrade Installation

9.11.6 High-Speed 4-Port SMD Option (25V98-4) Installation (Sheet 2 of 2)

SMD Panel Installation

- 1 Remove one blank I/O panel from rear panel assembly (►7.2.23) for each 4-port SMD DA installed.

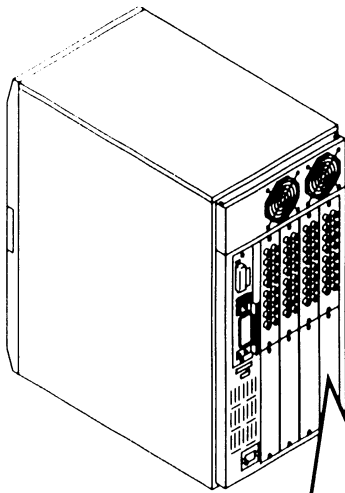

- 2 Install SMD Panel in the space vacated by blank I/O panel.

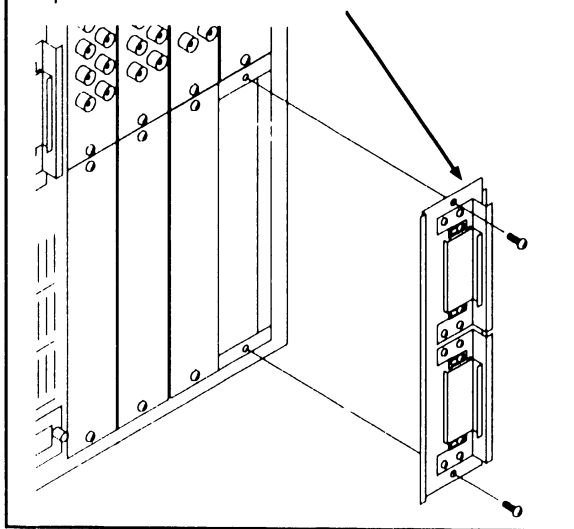

High-Speed 4-Port Cabling

- 1 Install the 'A' Cable and 'B' cables through the mainframe and connect the cables between the High-Speed 4-Port SMD and the SMD Panel as shown.

High-Speed 4-Port
SMD PCA
210-9415-A

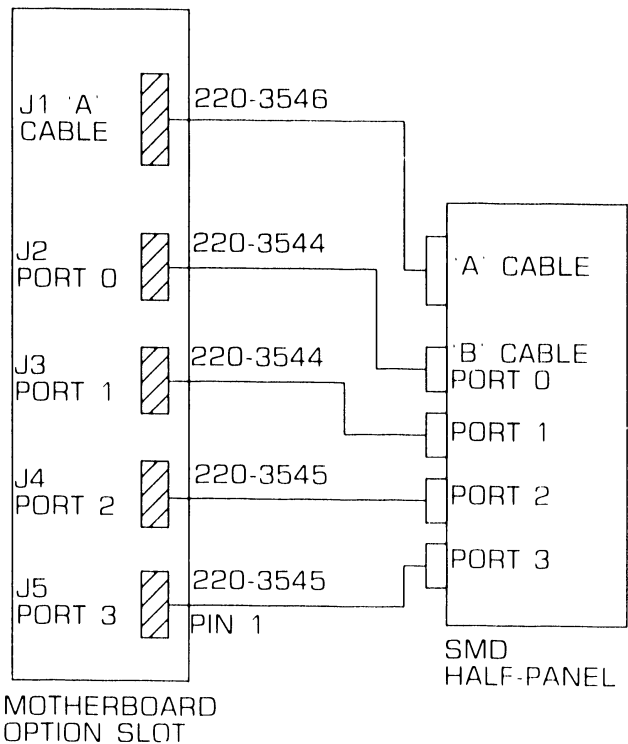

● END

9.11 UNPACKING AND SETUP

9.11.11 Option Board Upgrade Installation

9.11.7 UISIO Option (25V67) Installation (Sheet 1 of 2)

The UISIO Option allows the versatility to expand rear panel space with the use of the Small Cable Concentrator cabinet. This option also allows the use of the Global Modem which, must be located in the Small Cable Concentrator cabinet. This option contains:

- 210-8489-A PCA, VS-25/
45/65 U W/CNT

PCB Installation

- 1 Power-off the VS-75E and disconnect ac power. (▶4.2)
- 2 Remove top cover. (▶7.2.1)
- 3 Remove PCB Hold Down device. (▶7.2.4)
- 4 Set the UISIO PCA for address 0400 (or any available address). (▶7.2.13)

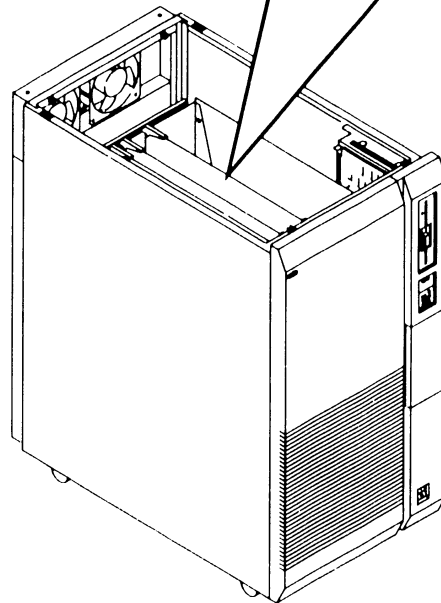
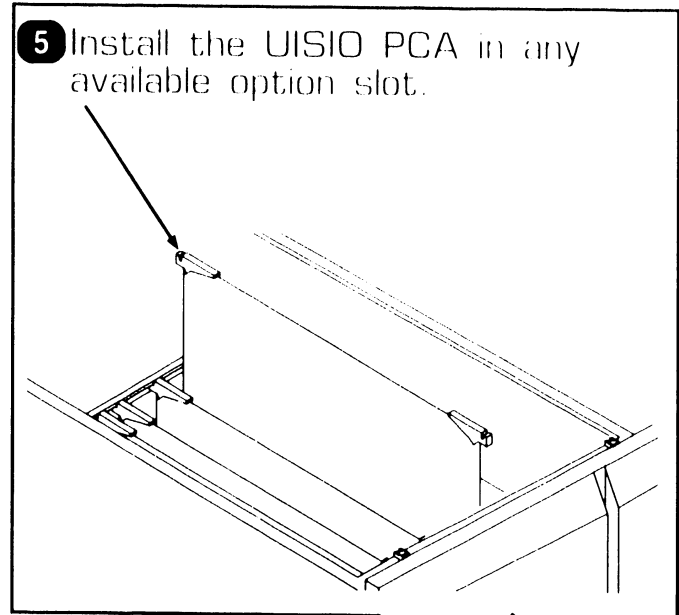

▶NEXT

9.11 UNPACKING AND SETUP

Option Board Upgrade Installation

9.11.7 UISIO Option (25V67) Installation (Sheet 2 of 2)

UISIO PCA Cabling

NOTE

Global modem power connector is not used in configurations using the cable concentrator.

UISIO Cabling is through the cable clamp located on the SCSI I/O Panel.

- 1) Install interconnect cables through the mainframe and connect cables to the UISIO PCA as shown.
- 2) Reference the 'VS Small Cable Concentrator' manual for option panel installation and cabling.

UISIO PCA
210 8489 A

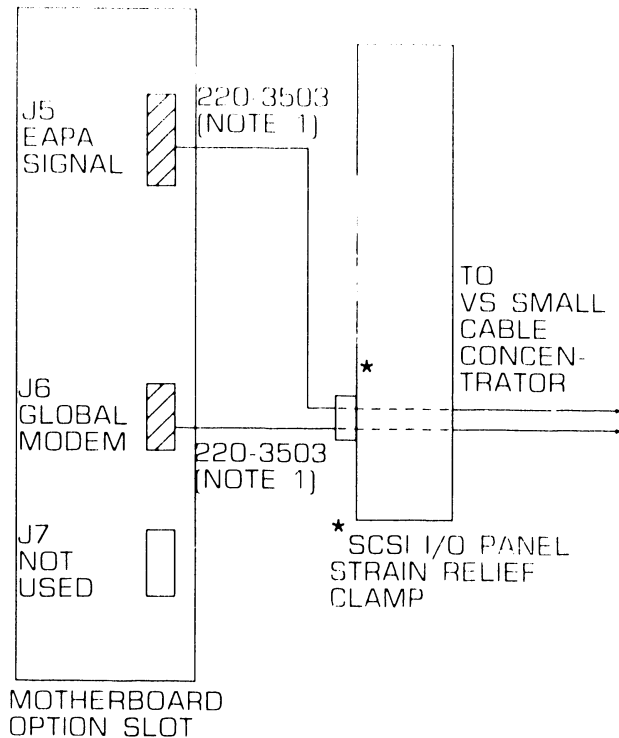

NOTES

- 1) CABLES 220-3503 ARE INCLUDED IN VS SMALL CABLE CONCENTRATOR CABLE KITS

● END

9.11 UNPACKING AND SETUP

Option Board Upgrade Installation

9.11.8 RSF Option Installation (Sheet 1 of 2)

The RSF Option provides the user with the ability to share resources between up to four VS computer system. The option contains:

- 210-8514-A RSF Controller PCA
- 270-1055 RSF Half-Panel
- 220-3469 Cable,
- 210-8172 Terminator,

PCB Installation

- 1 Power-off the VS-75E and disconnect ac power. (▶4.2)
- 2 Remove top cover. (▶7.2.1)
- 3 Remove PCB Hold Down device. (▶7.2.4)
- 4 Set the RSF PCA address to 0600 (or any available address). Set Device Address switch for configuration device address. (▶7.2.14)

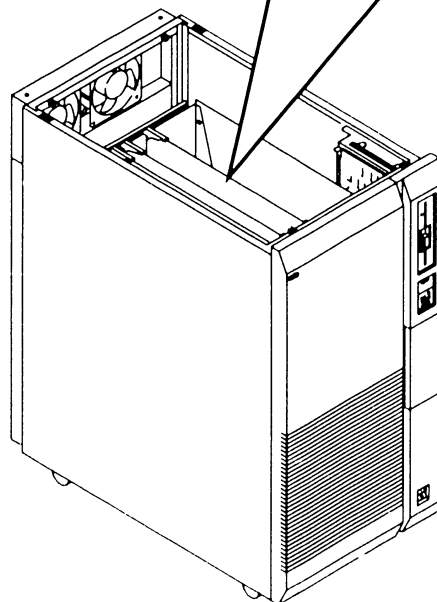
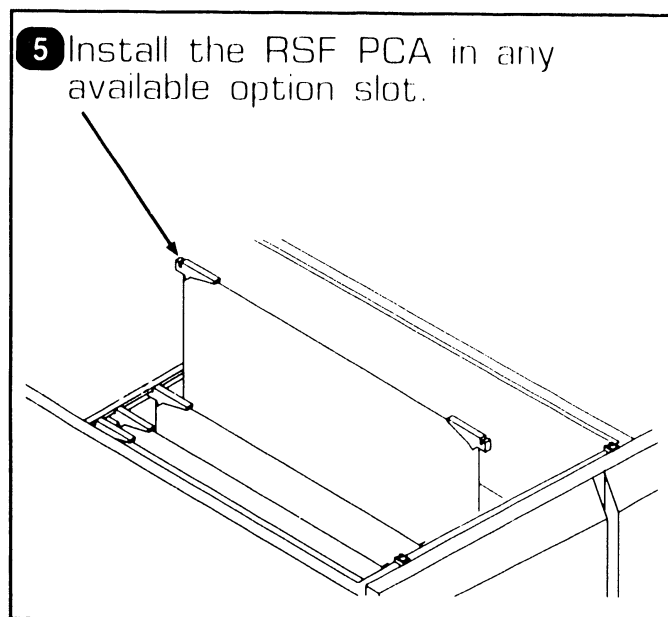

▶NEXT

9.11 UNPACKING AND SETUP

Option Board Upgrade Installation

9.11.8 RSF Option Installation (Sheet 2 of 2)

RSF Panel Installation

- 1 Remove one blank I/O panel from rear panel assembly (► 7.2.23).

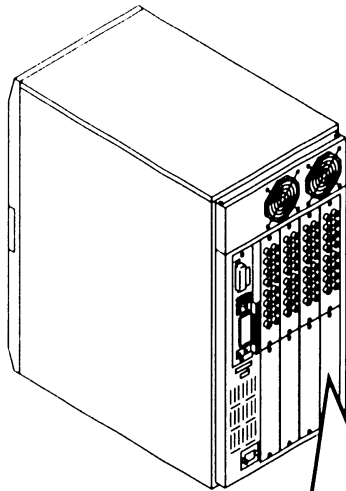

- 2 Install RSF Panel in the space vacated by blank I/O panel.

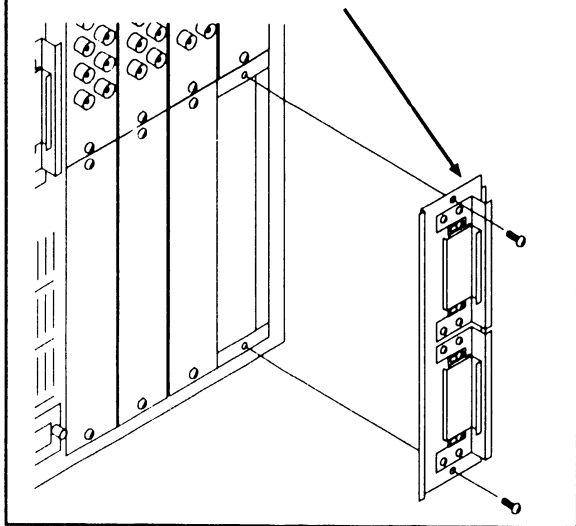

RSF PCA Cabling

- 1 Install the RSF Cable through the mainframe and connect it between the RSF PCA connector J1 and RSF Panel as shown.

RSF PCA
210-8514-A

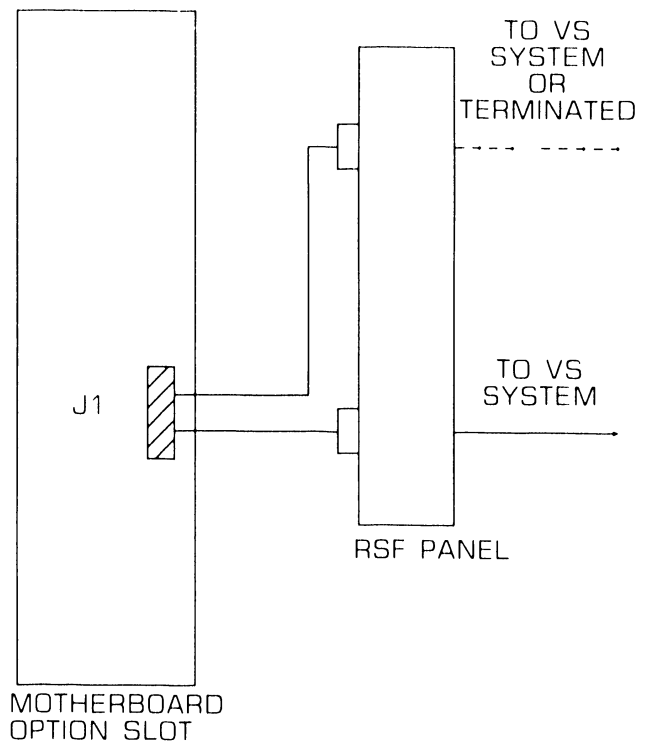

● END

9.12 UNPACKING AND SETUP

VS-75E Upgrade Kits

Upgrade kits are available to enhance mainframe capabilities. The following upgrade kits are presently available:

- UJ-3500 VS-75E 2MB to 4MB Upgrade (▶7.2.5)
- UJ-3501 VS-75E 2MB to 8MB Upgrade (▶7.2.5)
- UJ-3501 VS-75E 4MB to 8MB Upgrade (▶7.2.5)
- 289-0862 Optional 145MB 5-1/4 inch Winchester Drive (▶7.2.17)
- 289-0785 High-Speed Four Port SMD Controller (▶7.2.10)

● END

9.13 UNPACKING AND SETUP

VS Small Cable Concentrator

The VS Small Cable Concentrator (Model VS-SM-CC) can be used to provide additional bulkhead panel space for TC panels, Disk Controller panels, and Async Device controller panels. Additionally, if a Global Modem option is to be installed, the modem must be installed in the cable concentrator cabinet. Refer to the 'Small VS Cable Concentrator Maintenance Manual' (Class Code 6100) for system requirements and installation procedures.

The cable concentrator can house the following modular I/O Systems:

- Electrical APA Panels (EAPA)
- WangNet 'P' Band Panel
- FiberWay APA Panels (FWAPA)
- 802.3 LAN Controller Panel
- MLTC Panel

● END

9.14 UNPACKING AND SETUP

Latest PCB Revisions

The latest PCB revisions levels are listed below.

<i>PCB Number</i>	<i>Nomenclature</i>	<i>E Rev.</i>	<i>Mech. Rev.</i>
210-8415	RSF Controller	Rev 0	Rev 0
210-9699	VS-75E CPU	Rev 1	Rev 0
210-9095	VS-75E Bus Processor	Rev 2	Rev 0
210-9065	VS-75E Motherboard	Rev 0	Rev 0
210-9313	SMD 2-Port DA	Rev 0	Rev 1
210-9315	SMD 4-Port DA	Rev 0	Rev 0
210-9337	TC DA 1-Port	Rev 3	Rev 0
210-9355	Async Device Controller	Rev 1	Rev 0
210-9415	High-Speed 4-Port SMD DA	Rev 1	Rev 0
210-9637	TC DA 2-Port	Rev 2	Rev 0
210-9094-A	Cache Memory (2 MB)	Rev 2	Rev 0
210-9094-1A	Cache Memory (4 MB)	Rev 2	Rev 0
210-9094-2A	Cache Memory (8 MB)	Rev 2	Rev 0

● END

SECTION

10

**FUNCTIONAL
DESCRIPTION**

SECTION 10 CONTENTS

SECTION 10 FUNCTIONAL DESCRIPTION

	<u>Page</u>
10.1 INTRODUCTION	10-1
10.2 VS-75E COMPUTER SYSTEM ARCHITECTURE	10-2
10.3 SYSTEM BLOCK DIAGRAM DESCRIPTION	10-4
10.3.1 System Bus Structure	10-5
10.3.2 Bus Processor Description	10-6
10.3.3 Central Processor Unit (CPU) Description	10-11
10.3.4 Main Memory Description	10-12
10.3.5 Front Panel Description	10-13
10.3.6 Motherboard Description	10-14
10.3.7 Switching Power Supply Description	10-15
10.4 SYSTEM OPTIONAL CONTROLLER BOARDS	10-16

FUNCTIONAL DESCRIPTION

10.1 Introduction

The VS-75E Computer System is a high performance business system that offers both integrated word processing and data processing capabilities. The VS-75E supports up to 96 serial devices with a maximum of 64 workstations, one or two serial printers, Remote Maintenance, and an external SCSI Bus. The VS-75E architecture also includes 32 Kbytes of Cache Memory to speed execution time. The following lists major features of the VS-75E computer system.

- CP7-Based CPU with 32-bit Main Memory access; 16-bit direct access to Main Memory via CPU-only C Bus, MX bus, and MDI Bus Interface, and 16-bit access to Main Memory via Main Memory Bus.
- 2, 4, or 8 Mbyte Main Memory with 32 Kbyte Cache Memory.
- An 80186-based Bus Processor with 512 Kbyte of Code RAM, 64 Kbyte of Data RAM, 16 Kbyte of PROM, a Floppy Drive Interface, a SCSI Bus Interface to control up to two internal SCSI-based Winchester Disk Drives and five external SCSI-based device, an APA Interface that supports up to 64 serial data link devices, two serial RS232 ports for Remote Diagnostics and serial printer support, a Front Panel Interface, a BP I/O Bus Interface, a Main Memory Bus Interface, and a DRAM Bus Interface.
- Double-Sided High Density 1 1/2 Mbyte 5 1/4" Mini Floppy Drive.
- 145 Mbyte or 290 Mbyte of internal Winchester storage using one or two 145 Mbyte Winchester Drives.
- Fan cooled 1000 watt Switching Power Supply with built-in Power Distribution Unit (PDU).
- Optional One-Port or Two-Port Telecommunications Controller that supports RS232, RS366, and X.21 protocols.
- Optional Two-Port or Four-Port SMD Controller that supports up to four external disk drives.
- Optional Four-Port High Speed SMD Controller that supports up to four external high-speed disk drives.
- Optional Async Device Controller for Async workstation support.
- Optional Serial Device Controller for external support of additional EAPA, FiberWay APA, and P-Band Modem.

● END

FUNCTIONAL DESCRIPTION

10.2 VS-75E Computer System Architecture (Sheet 1 of 2)

The VS-75E Computer System is a nine slot system with three standard boards, a CPU board (CP7 based), a Memory board and a Bus Processor board. Six slots are available for option boards.

The CPU board executes VS system instructions and application program code, and controls virtual memory operations. The CPU board has direct 16-bit access to Main Memory through CPU accessible-only C Bus, MX Bus, and MDI Bus and also has 16-bit access to Main Memory through Main Memory Bus, thus providing a 32-bit data path to Main Memory.

The Main Memory board is available in configurations of 2 Mbyte, 4 Mbyte, or 8 Mbyte of memory with future configurations of up to 16 Mbytes. The Main Memory board contains the physical memory devices, 32 Kbytes of Cache Memory, memory arbitration, and control signals logic.

The Bus Processor board performs all bus related activities acting as I/O controller for the system. The BP board contains a microprocessor, 512K Bytes of Code Ram (CRAM), and 64 Kbytes of Data RAM (DRAM) which allow the BP to process system tasks concurrently with CPU, thus freeing the CPU for higher

priority tasks. The BP also contains device controllers for the Floppy Diskette Drive, 32 port 928 Serial Interface, RS232 Serial Interface, and SCSI Interface that controls the SCSI-embedded Winchester Disk Drives.

◆NEXT

10.2 FUNCTIONAL DESCRIPTION

VS-75E Computer System Architecture

(Sheet 2 of 2)

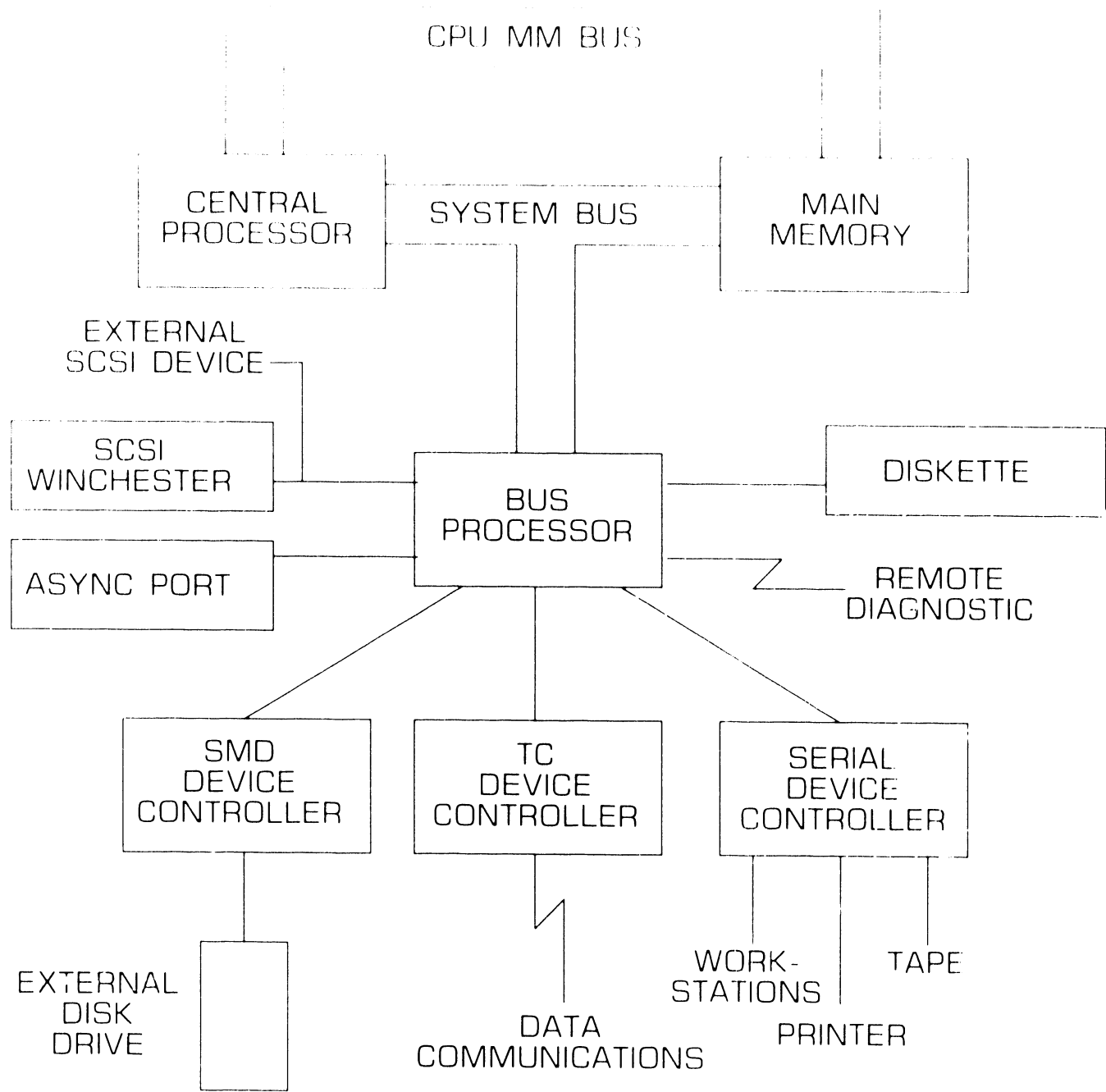

● END

FUNCTIONAL DESCRIPTION

10.3 System Block Diagram Description

This section discusses theory of operation for V35-75E at a functional block diagram level. It is intended to supply Customer Engineering personnel with information necessary to obtain a basic understanding of the system design.

● END

FUNCTIONAL DESCRIPTION

10.3 System Block Diagram Description

10.3.1 System Bus Structure

The flow of information between various PC boards in the system occurs on the system's three separate buses, the BP I/O Bus (Bus Processor Input Output Bus), the BP DRAM Bus (Bus Processor Direct Memory Access Bus), and the Main Memory Bus. All buses are bi-directional and are under the control of the Bus Processor. The BP I/O Bus is comprised of 69 signals representing address, data, select, and control information. The BP I/O Bus controls all boards in the system, loads the CPU and option boards with microcode, performs a read of all boards status, and starts and halts the CPU.

The BP DRAM Bus is comprised of 74 signals representing DMA address, DMA data, DMA requests, DMA grants, and DMA control signals for DMA transfers. The BP DRAM Bus controls all DMA transfers between option boards, Main Memory, and CPU.

The Main Memory Bus contains 54 signals representing memory address, memory data, and memory control signals. Twenty-four memory address lines are available providing access up to 16 Mbytes of Main Memory.

The VS-75E system contains three CPU accessible-only buses which are, C Bus, MX Bus, and MDI Bus. The C Bus is a 'write-to-memory only bus', that provides Main Memory with data and instructions for loading the Memory Address Registers (MARS), the Translation RAM (T-RAM), and various other memory board registers. The MX Bus provides a 16-bit read-from-memory data path. The MDI Bus provides a 16-bit data input path from the 32 Kbytes of CACHE Memory on the memory board.

● END

FUNCTIONAL DESCRIPTION

10.3 System Block Diagram Description

10.3.2 Bus Processor Description (Sheet 1 of 4)

The Bus Processor (BP) performs all bus related activities acting as I/O controller for system, thus freeing the CPU for higher priority tasks. The Bus Processor is designed around an 80186 microprocessor, which operates concurrently with the CPU. The Bus Processor relieves the CPU of all I/O control, DMA control, system tasks, and also controls all option boards in the system. The main functions of the Bus Processor are:

- Control and execution of all System Buses:
 1. DRAM Bus for DMA (block) transfers.
 2. BP I/O Bus for all I/O operations (i.e. SMD reads/writes).
 3. Main Memory Bus read/write operations.
- Control and execution of all operations involving the 5 1/4" Floppy Drive.
- Control and execution of all operations involving the asynchronous SCSI Interface Bus.
- Control and execution of up to 32 serial 928 data link ports (via Active Port Assemblies [APA]) on its MuxBus Interface.

- Control and execution of two asynchronous printer ports.
- Control Front Panel Interface.

An 80186 microprocessor operating at 10 MHz controls the Bus Processor, and operates from the instruction code stored in Code RAM (CRAM) and PROM. The Bus Processor contains 576 Kbytes of RAM overlaid with 16 Kbytes of PROM. The lower 512 Kbytes of RAM functions as Code RAM and contains the Bus Processor operating code. The operating code is loaded into CRAM by either the 5 1/4" floppy, SCSI winchester drive, or a SMD drive. The next 64 Kbytes of RAM function as Data RAM (DRAM). DRAM is used to buffer all data from either an on-board source (floppy, SCSI, serial 928 data link, or 80186) or external device adapters before being transferred to/from main memory. The 16 Kbytes of PROM contain diagnostic Built-In-Test (B.I.T.) microcode and the 80186 power-up initialization code.

►NEXT

FUNCTIONAL DESCRIPTION

10.3 System Block Diagram Description

10.3.2 Bus Processor Description (Sheet 2 of 4)

The BP controls all Floppy Drive operations through a LSI Single Double Density Floppy Controller chip (FDC) and Dual Phase Lock Loop Interface. The Dual Phase Lock Loop interface supports both the standard 1.2 Mbyte high density floppy drive and the optional 360 Kbyte low density floppy drive. A Floppy Interface Data Ordinator (FIDO) device is used for the floppy data separator. This device allows floppy drive operation at either 250 Kbytes per second for low density drive support (360 KB low density drive) or 500 Kbytes per second for high density drive support (1.2 MB high density drive).

The BP controls the SCSI Interface (Small Computer System Interface) through a SCSI Protocol Controller chip. The SCSI Protocol Controller operates in both initiator and target roles and provides control, arbitration, and address/data (8-bits plus parity) signals required for the SCSI Bus. The BP is set up as the initiator. Up to eight SCSI devices/targets (i.e. disks, tapes, printers) can be supported by SCSI Protocol Controller. The SCSI Protocol Controller chip communicates to either DRAM memory, CRAM memory, or Main Memory through DMA transfers. The controller chip will interrupt the 80186 when bus service (data transfer) is

requested. All data transfers are in word mode (2 bytes). Data transfer to DRAM will swap low byte and high byte through the Byte Swap circuitry located on the BP. Data transfers to CRAM are not byte swapped. The SCSI Bus uses the signals described below to communicate and control the SCSI devices on the bus.

►NEXT

10.3 FUNCTIONAL DESCRIPTION

System Block Diagram Description

10.3.2 Bus Processor Description (Sheet 3 of 4)

<i>Signal</i>	<i>Mnemonic</i>	<i>Description</i>
BUSY	-BSY	A signal that indicates the bus is being used.
SELECT	-SEL	A signal used by the Initiator to select a Target or by a Target to reselect the Initiator.
COMMAND DATA	-C/D	A signal driven by the Target indicating whether command (C) or data (D) information is on the bus.
INPUT OUTPUT	-I/O	A signal driven by the Target which controls the direction of the data movements on the data bus with respect to the Initiator. I denotes input to target, O denotes input to Initiator.
MESSAGE	-MSG	A signal driven by the Target indicating message phase.
REQUEST	-REQ	A signal driven by the Target indicating a request for a data byte transfer.
ACKNOW- LEDGE	-ACK	A signal driven by the Initiator to indicate acknowledgment for a Request/Acknowledge transfer.
ATTENTION	-ATN	A signal driven by the Initiator to indicate an Attention condition, where the Initiator wants to transfer a message byte to the Target.
RESET	-RES	A signal that indicates a reset condition.

►NEXT

FUNCTIONAL DESCRIPTION

10.3 System Block Diagram Description

10.3.2 Bus Processor Description (Sheet 4 of 4)

The BP MuxBus Interface is a 928 Serial Data Link Interface providing eight MuxBus channels. Each channel supports eight 928 Serial Data Link devices (i.e. serial workstations, serial printers) through Electrical Active Port Assemblies (EAPA). Although the BP supports 64 serial data devices, software limits number of devices to 32. The MuxBus Interface contains all transmit and receive logic for external serial device ports that connect the VS-75E to 928-type serial devices. The MuxBus channel 0 port 0 is dedicated for operator console (system administrator) and must have a serial workstation attached. All error codes, operator inquiries, and system status are reported to this port and are displayed on the operators console.

Two Asynchronous Printer Ports (denoted A and B) are supported by the BP board. Printer Port A provides the asynchronous link for either Remote Maintenance or a RS232 serial printer. Printer Port B provides the asynchronous link for a general purpose RS232 device only. A Dual Universal Asynchronous Receive/Transmit chip (DUART) controls these ports.

The Front Panel is under control of BP and contains the error code hex display and operator control pushbut-

tons; Initialize, and Control Mode. The Front Panel also contains two LEDs; Power-On and Ready. Power-On Led when illuminated displays dc power is present. Ready LED when illuminated denotes BIT diagnostics are running. When the LED turns off, it signifies the diagnostics passes and the system is running the operating system.

All information exchanged between the Central Processing Unit and various peripheral controllers (SMD, TC) travels via Bus Processor controlled buses. With these buses, the CPU is able to exchange information with a total of eleven logical devices, six of which correspond to the six motherboard slots which house various peripheral controllers (SMD, TC, UISIO, etc.). Five of the logical devices residing on the Bus Processor are; Floppy Drive, SCSI (Winchester) port [up to eight SCSI-based devices can be daisy chained through SCSI port logic], MuxBus Interface, and Async Printer ports A & B.

● END

10.3 System Block Diagram Description

FUNCTIONAL DESCRIPTION

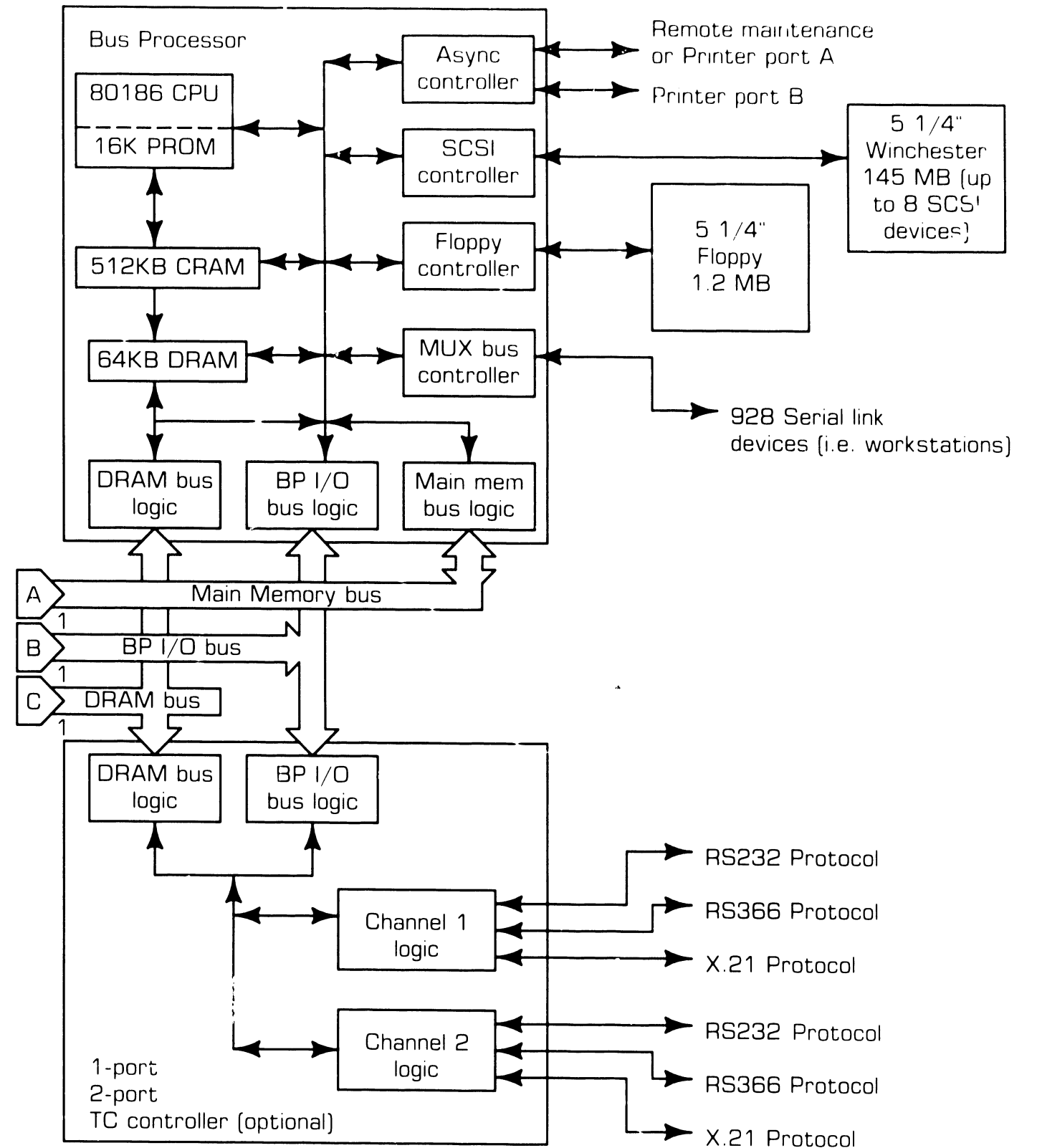
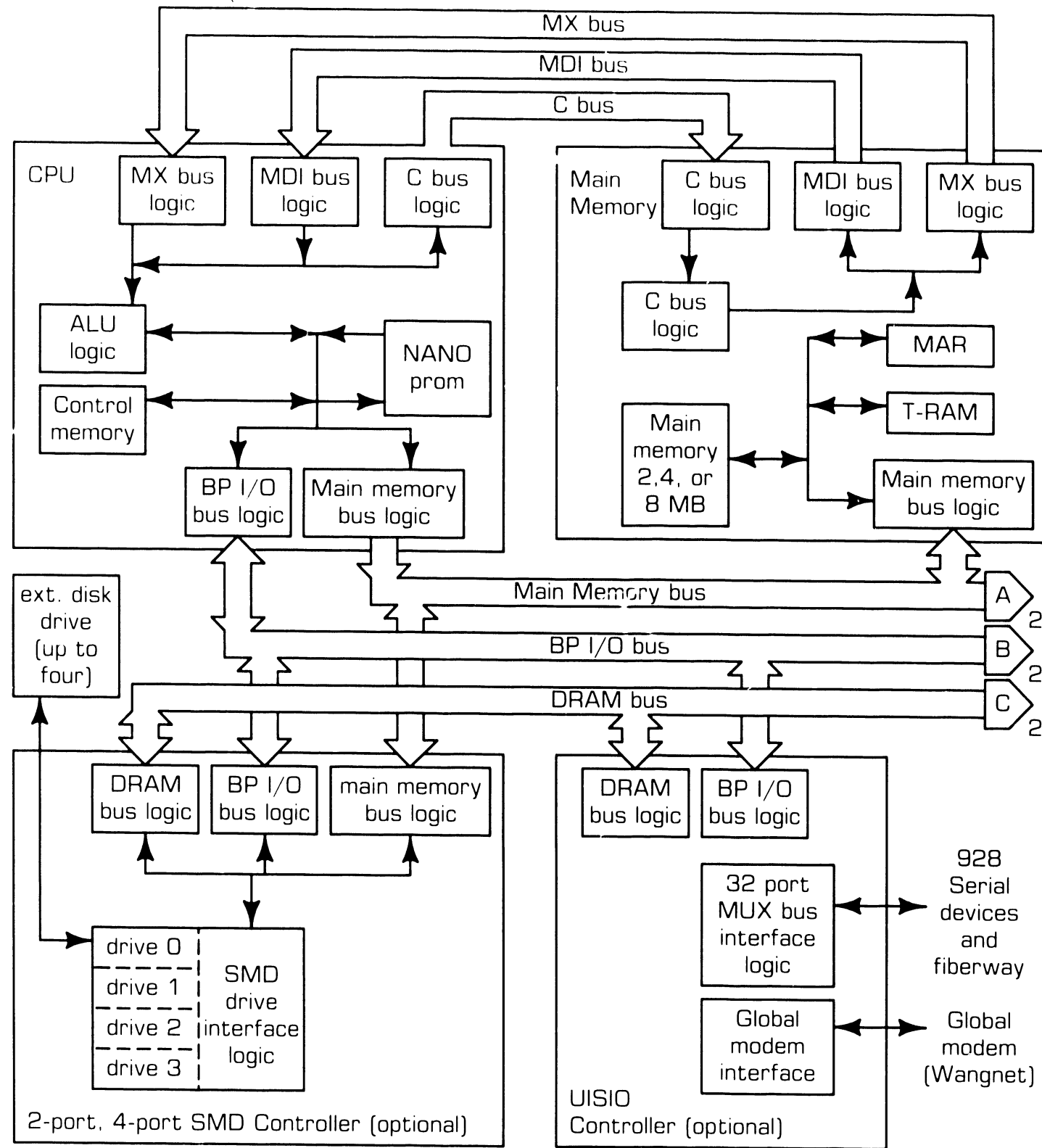

● END

FUNCTIONAL DESCRIPTION

10.3 System Block Diagram Description

10.3.3 Central Processor Unit (CPU) Description

The CPU board executes VS system instructions and application program code and controls virtual memory operations. The CPU has direct 16-bit access to Main Memory through the CPU accessible-only C Bus, MX Bus, and MDI Bus. In addition, a 16-bit access to Main Memory through the Main Memory Bus exists, thus providing a 32-bit data path to Main Memory. The CP board contains 32 Kbytes of Control Memory which contains CP7 microcode and routines. The VS-75E CPU processes microcode instructions stored in Control Memory using high speed PAL (Programmable Array Logic) devices. The high speed PALs simplify control logic design. A six bit micro-opcode and a two bit cycle counter address the PALs which provide four control words for each of 64 micro-instructions. These instructions provide the individual signals that control the data paths and memory addressing logic within the CPU.

● END

FUNCTIONAL DESCRIPTION

10.3 System Block Diagram Description

10.3.4 Main Memory Description

The CPU board must be paired with the Main Memory board as the Main Memory board contains the logic devices for T-RAM, Memory Address Registers (MARS), Page Table RAM, and memory support circuitry. Main Memory consists of either 2 Mbyte, 4 Mbyte, or 8 Mbyte of memory devices. 256K RAM SIMM modules or 1MB RAM SIMM modules are used for the physical memory devices. Main Memory contains T-RAM logic, memory address select logic, memory control signal logic (RAS, CAS), and parity error detection and correction logic. Main Memory is directly accessible to the CPU through CPU-accessible only C Bus, MX Bus, and MDI Bus. The BP board and some option boards are capable of accessing Main Memory via the Main Memory Bus.

Main Memory contains 32K bytes of CPU-only accessible CACHE Memory. The CPU receives information being processed from CACHE Memory on the 16-bit wide MDI Bus. Information and data being stored to memory by the CPU is placed on the Main Memory Bus and latched into Main Memory.

All data written to memory has a parity bit assigned and stored with the data. When the CPU reads data, the data bit pattern is checked against

the parity bit. If parity matches the data pattern, the data is transferred to the CPU for processing.

● END

FUNCTIONAL DESCRIPTION

10.3 System Block Diagram Description

10.3.5 Front Panel Description

The Front Panel is controlled by the Bus Processor, and is used for operator interface and operator information/status. It contains two pushbutton switches (Initialize and Control Mode), two status LEDs (Power-On and Not Ready), and four HEX LEDs. The four HEX LEDs display system status during power-up and self-test, and are used as a visual means to verify that the Power-Up BIT Test and IPL (Initial Program Load) are in process. If an error occurs during power-up or self-test, an error code will be displayed on the LEDs.

The keyswitch and boot device switch is cabled to the front panel. The keyswitch and boot device switch are read by the BP during initialization. The boot device switch is decoded by the BP, providing the information required to enable the selected boot device. The keyswitch is functional in Local Control (normal operation) and Remote Control (remote maintenance) positions.

● END

FUNCTIONAL DESCRIPTION

10.3 System Block Diagram Description

10.3.6 Motherboard Description

The Motherboard is designed to accommodate a total of nine printed circuit boards. Three of these boards must be the CPU, Main Memory, and Bus Processor. The six remaining slots accommodate different option boards that can be installed. These option boards may include; Two-Port or Four-Port External SMD Controller, One-Port or Two-Port Telecommunications Controller, Asynchronous Device Controller, Universal Intelligent Serial Input/Output Controller (UISIO) and the High Speed Four-Port SMD Controller.

● END

FUNCTIONAL DESCRIPTION

10.3 System Block Diagram Description

10.3.7 Switching Power Supply Description

The Switching Power Supply provides five output voltages: +5, -5, +12, -12, and +24 volts dc. The power supply input circuits convert the ac line voltage (either 115V or 230V) into rectified and filtered high voltage dc. The high voltage dc is chopped at a frequency of 25 KHz by a pulse width generator, which presents the high voltage pulsating dc to a multiple output transformer. This transformer steps down the high voltage pulsating dc.

All output voltages are full-wave rectified through their associated diode rectifier circuits. The +5 volts and +12/24 volts are adjustable and are accessible from outside of the power supply enclosure. These adjustments feeds a voltage sense circuit that controls the width (on time) of the pulse width generator. The +5 volts sets-up all other voltages.

The Switching Power Supply contains a Power Distribution Unit (PDU). The PDU provides six 6-pin connectors supplying a source of power for the option panels mounted on the rear panel assembly.

◆ END

FUNCTIONAL DESCRIPTION

10.4 System Optional Controller Boards (Sheet 1 of 3)

Four types of optional peripheral controller boards may be included in the VS-75E Computer System. These are: External SMD Controller (Two-Port, Four-Port), Telecommunications Controller (One-Port, Two-Port), Universal Intelligent Serial Input/Output Controller (UISIO), and Asynchronous Device Controller. A brief description of each boards functional responsibilities is contained in the following paragraphs.

External SMD Controller (Two-Port, Four-Port, High-Speed Four-Port)

The VS-75E is capable of supporting up to four external disk drives. Depending on the system configuration, either the Two-Port, Four-Port, or High-Speed Four-Port SMD Controller can be installed in an available motherboard bus slot. The SMD Controller is responsible for providing:

- Interface signals (Control and Data) to selected external drive.
- Multi-sector operations without Bus Processor intervention.
- Interface Logic to the Bus Processor to enable communications on the BP I/O bus, Main Memory Bus, and DRAM Bus.

- Support disk formats of up to 64 sectors per track, with sector sizes of 256 bytes and/or 2048 bytes.
- Perform error correction of disk data.

➡ NEXT

FUNCTIONAL DESCRIPTION

10.4 System Optional Controller Boards (Sheet 2 of 3)

Telecommunications Controller (One-Port, Two-Port)

The VS-75E is capable of supporting up to three Telecommunications Controllers per system. Depending on the system configuration, either the One-Port, Two-Port, or a combination of Telecommunications Controllers can be installed. Each Telecommunications Controller contains a Z80 Microprocessor for each port (channel), 128 Kbytes of RAM storage, and a Power-Up PROM for checking its internal status during initial Power-On. The Telecommunications Controllers are responsible for providing:

- Support RS232-C, RS366, and X.21 modem interfaces at speeds up to 19.2 KBaud.
- Perform NRZ or NRZI line decoding.
- Manage asynchronous, bisynchronous, and bit-oriented synchronous protocols.
- Formatting parallel data to serial communications data, and formatting serial communications data into parallel data.
- Interface Logic to the Bus Processor to enable communications on the BP I/O Bus, Main Memory Bus, and DRAM Bus.

Universal Intelligent Serial Input/Output Controller (UISIO)

The VS-75E is capable of supporting one UISIO Controller per system. The UISIO Controller provides eight MuxBus channels for support of additional serial devices via EAPAs, remote devices via FiberWay links, and P-Band Devices via a Global Modem. Note that due to rear panel space limitations, the use of UISIO Controller requires the Small Cable Concentrator for mounting panel assemblies (Modem, FWAPA, EAPA). The UISIO Controller contains a Z80 Microprocessor, 128 Kbytes of RAM storage, and a Power-Up PROM for checking its internal status during initial power-on. The UISIO Controller is responsible for providing:

- Interface logic to the Bus Processor to enable communications on the BP I/O bus and DRAM Bus.
- Eight MuxBus channels for support of EAPAs and FiberWay panels.
- (Note each EAPA panel requires one MuxBus channel, each FiberWay panel requires two MuxBus channels.)
- Supports P-Band Global Modem.

➡NEXT

FUNCTIONAL DESCRIPTION

10.4 System Optional Controller Boards (Sheet 3 of 3)

Asynchronous Device Controller

The VS-75E is capable of supporting one Asynchronous Device Controller. The Asynchronous Device Controller provides eight RS232-C serial interface logic ports that supports the model 2110 and 2110-A asynchronous workstations. The Asynchronous Device Controller is responsible for providing:

- 4 MHz 8086 Microprocessor performing task-related duties.
- Power-Up PROM for checking internal status during initial power-on.
- Eight RS232-C Logic Interfaces using four dual-channel serial controllers.
- Interface logic to the Bus Processor to enable communications on the BP I/O Bus and DRAM Bus.
- 256K RAM Memory with parity.

● END

SECTION

11

SPECIFICATIONS

SECTION 11 CONTENTS

SECTION 11 SPECIFICATIONS

	<u>Page</u>
11.1 HARDWARE	11-1
11.1.1 VS-75E Mainframe	11-1
11.1.2 145MB Winchester Drive Specifications	11-2
11.1.3 SPS714 Switching Power Supply Specifications	11-3
11.1.4 1.2MB Floppy Drive Specifications	11-4
11.2 SOFTWARE SPECIFICATIONS	11-5
11.2.1 VS-75E Minimum Operating System Software	11-5

SPECIFICATIONS

11.1 Hardware

11.1.1 VS-75E Mainframe

Computer System Dimensions:

Depth: 27.5 inches (69.9 cm)
Width: 15.4 inches (39.1 cm)
Height: 30.5 inches (77.5 cm)

Computer System Weight:

138 pounds (62.1 Kg) Minimum
Configuration

Installation Requirements

Front Clearance: 13 inches
(33.02 cm)
Rear Clearance: 13 inches
(33.02 cm)
Side Clearance: 14 inches
(35.56 cm)
Position: Upright Only

Power Requirements:

Dedicated circuit

90-132 Vac (115 Vac nominal)
60 Hz +/- 0.5 (60 Hz nominal)
8.0 Amps RMS @ 115 Vac
(920 volt-amps)

180-264 Vac (230 Vac nominal)
50 Hz +/- 0.5 (50 Hz nominal)
4.0 Amps RMS @ 230 Vac

NEMA Receptacle 5-151G
NEMA Plug 5-15IP

Environmental Requirements:

Relative Humidity:
20% - 80% non-condensing
Ambient Temperature:
60° - 90°F (15.5° - 32° C)
Max Temp Gradient:
12°F/Hr (4°C/Hr)
Max Wet Bulb Temp:
75°F (24°C)
Max Altitude:
10,000 Ft (3.048 Km)
Heat Dissipation:
729 Watts (2488 BTU/Hr)

Memory Cycle Time:

200 nSeconds microinstruction
180 nSeconds CPU memory read

Memory Size:

2 Meg, 4 Meg, or 8 Meg,
32 Cache

Number of Users:

64 Concurrent Users

Maximum Serial Devices:

96 Serial Devices

● END

SPECIFICATIONS

11.1 Hardware

11.1.2 145MB Winchester Drive Specifications

Drive Dimensions:

Depth: 8.00 inches (203 mm)
Width: 5.75 inches (146 mm)
Height: 3.25 inches (82.6 mm)
Weight: 6.0 lbs. (2.7 Kg)

Power Dissipation:

Standby: 33 Watts,
119.5 BTU/Hr
Positioning: 40 Watts,
136.5 BTU/Hr

Drive Performance:

Capacity:
145 MB Formatted
Transfer Rate:
1.25 MB/Second (Maximum
Continuous)
1.50 MB/Second (Maximum
Burst Mode)
Seek Time:
Track-to-Track 5 msec
Average 23 msec
Maximum 50 msec
Rotational Latency:
Average 8.33 msec
Nominal 16.76 msec
Start Time:
20 seconds maximum to
drive ready
Stop Time:
20 Seconds Nominal

Power Requirements:

+5 Vdc +/-5% @ 0.9 Amps Idle,
0.9 Amp Peak
+12 Vdc +/-5% @ 2.1 Amps Idle,
3.9 Amps Peak

● END

SPECIFICATIONS

11.1 Hardware

11.1.3 SPS714 Switching Power Supply Specifications

Dimensions:

Depth: 17.66 inches (44.86 cm)
Width: 6.28 inches (15.95 cm)
Height (front): 4.60 inches
(11.68 cm)
Height (rear): 5.40 inches
(13.71 cm)

Output Voltages:

+5 Vdc:

Adjustment Range: 4.75 to 5.25
Volts
Output Current: 15 to 100 Amps
Ripple: 50 mvp-p at full Load (0-
1Khz)

+12 Vdc:

Adjustment Range: 11.80 to 12.20
Volts
Output Current: 4 to 14 Amps
Ripple: 50 mvp-p at full Load (0-
1Khz)

+24 Vdc:

Adjustment Range: 22.80 to 25.20
Volts
Output Current: 1 to 3 Amps
Ripple: 75 mvp-p at full Load (0-
1Khz)

-5 Vdc (not adjustable):

Adjustment Range: -4.75 to -5.25
Volts
Output Current: 0 to 3 Amps
Ripple: 50 mvp-p at full Load (0-
1Khz)

-12 Vdc (not adjustable):

Adjustment Range: -11.80 to -12.
20 Volts
Output Current: 0 to 3 Amps
Ripple: 50 mvp-p at full Load (0-
1Khz)

Power Dissipation:

Steady State:
719 Watts, 4095 BTU/Hr

● END

SPECIFICATIONS

11.1 Hardware

11.1.4 1.2MB Floppy Drive Specifications

Drive Dimensions:

Depth: 8.46 inches (214.9 mm)
Width: 5.75 inches (146 mm)
Height: 1.62 inches (41.8 mm)

Drive Performance:

Capacity:
1.2MB Formatted
Transfer Rate:
250K bits/second
Access Time:
Track-to-Track 3 msec
Average 94 msec
Setting 15 msec

Power Requirements:

+5 Vdc:
+/-5% @ 0.7 Amp Typical,
0.9 Amps Peak
+12 Vdc:
+/-10% @ 0.75 Amp Typical,
1.2 Amps Peak

Power Dissipation:

Standby:
3.6 Watts, 12.3 BTU/Hr
Continuous:
12.5 Watts, 42.7 BTU/Hr

● END

11.2 Software Specifications

SPECIFICATIONS

11.2.1 VS-75E Minimum Operating System Software

<i>Software</i>	<i>Version</i>	<i>Comments</i>	<i>WLI P/N</i>
Operating System	7.13		195-5560-x

NOTE

- x - C - Cartridge Tape
 - E - 1.2MB 5-1/4" Diskette
 - G - Streamer Tape
-

● END

11.3 Diagnostic Specifications

SPECIFICATIONS

11.3.1 VS-75E Built-In-Test (BIT)

<i>Diagnostic Name</i>	<i>PROM Rev.</i>	<i>Package P/N</i>	<i>PROM Location/ Part Number</i>
Bus Processor PROM	5761	195-4995-D	L157 - 379-2105 L156 - 379-2106

NOTES

- 1) Complete 195 package part numbers include PROMS and documentation.

● END

11.3 Diagnostic Specifications

SPECIFICATIONS

11.3.2 Diagnostics

<i>Diagnostic Name</i>	<i>Release</i>	<i>Package P/N</i>
Small VS BP2 Class System Diagnostic (See Notes)	2762	195-5084-0 (1.2MB diskette version)

NOTES

- 1) Complete 195 package part numbers include diskettes and documentation.
 - 2) Diagnostic package contains Self-Test diagnostics and monitor diagnostics.
 - 3) 360KB diskette version available under part number 195-5285-9.
-

● END

SECTION 12
ILLUSTRATED
PARTS

SECTION 12 CONTENTS

SECTION 12 ILLUSTRATED PARTS

	<u>Page</u>
12.1 MAJOR ASSEMBLIES	12-1
12.2 SUBASSEMBLIES	12-2
12.2.1 VS-75E Computer System Covers	12-2
12.2.2 VS-75E Computer Chassis	12-4
12.2.3 VS-75E Computer Card Cage	12-6
12.2.4 VS-75E Rear Panel Assembly	12-8
12.3 VS-75E INTERCONNECT DIAGRAM	12-10
12.4 CABLE ASSEMBLIES	12-12
12.4.1 Standard Cable Assemblies	12-12
12.4.2 Optional Cable Assemblies	12-13

12.1 Major Assemblies

ILLUSTRATED PARTS

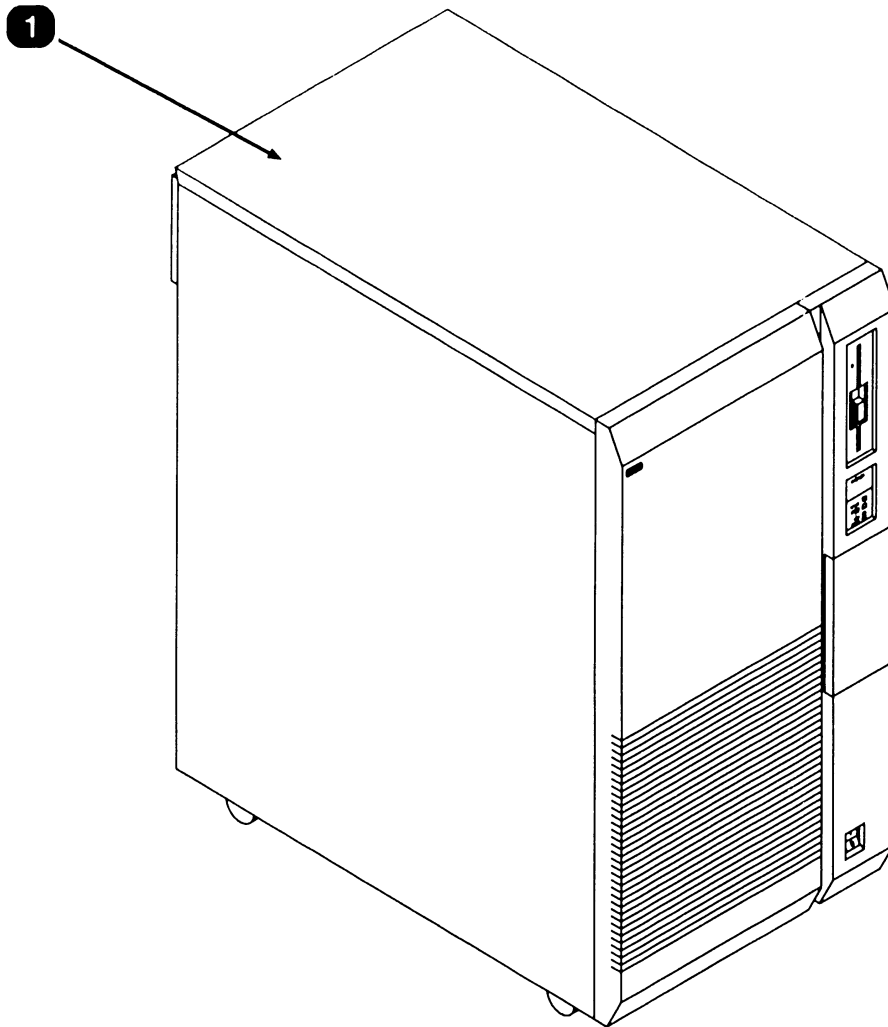

<i>Item</i>	<i>Part Number</i>	<i>Description</i>
1	177-7545	VS-75E Computer System, 2MB Main Memory
	177-7546	VS-75E Computer System, 4MB Main Memory
	177-7547	VS-75E Computer System, 8MB Main Memory

● END

12.2 **ILLUSTRATED PARTS**

Subassemblies

12.2.1 VS-75E Computer System Covers (Sheet 1 of 2)

<i>Item</i>	<i>Part Number</i>	<i>Description</i>
1	400-9016	Guard, Fan (2 ea.)
2*	270-0905	EAPA Assembly
3	270-1085	Panel, SCSI I/O
4	452-4857	Rear Panel
5*	270-3425	Fan Assembly, DC (two fans)
6	458-3971	Cover, Top
7	458-3294	Panel, Left Side
8	458-3332	Frame, Weldment
9	655-0601	Casters, Swivel
10	655-0213	Leveler, Leg
11	458-3293	Panel, Right Side
12	655-0060	Casters, Rigid
13	452-1225	Panel, I/O Blank (Half)

* - Field Replaceable Item

►NEXT

12.2 ILLUSTRATED PARTS

Subassemblies

12.2.1 VS-75E Computer System Covers (Sheet 2 of 2)

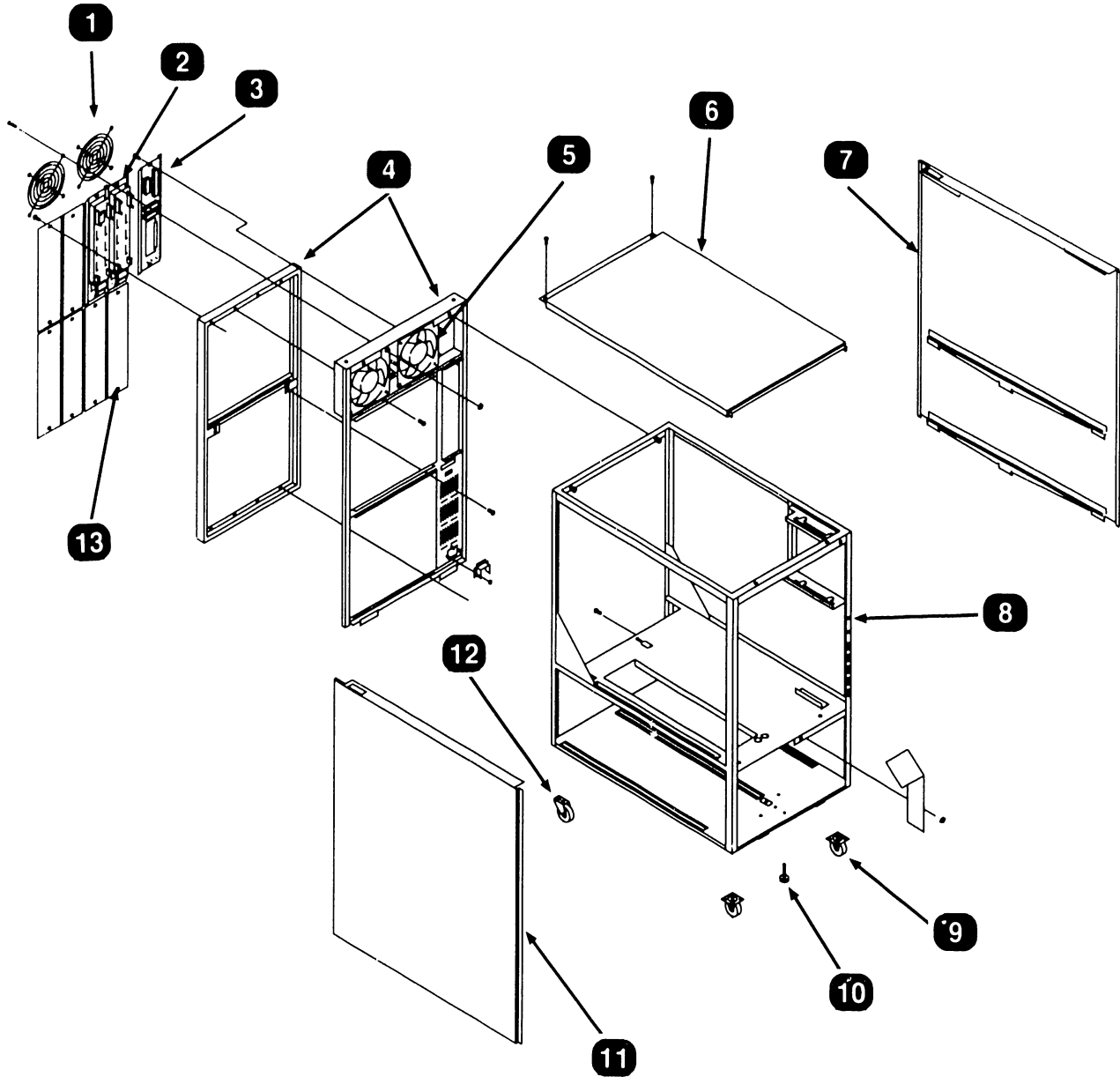

● END

12.2 **ILLUSTRATED PARTS**

Subassemblies

12.2.2 VS-75E Computer Chassis (Sheet 1 of 2)

<i>Item</i>	<i>Part Number</i>	<i>Description</i>
1*	725-0232 725-0142	Floppy Diskette Drive, 1.2 MB Floppy Diskette Drive, 360KB (Optional)
2	272-0059 *210-9096	Front Panel Assembly PCA, Front Panel
3*	279-0607 325-0009	Keylock Assembly SPDT Toggle Switch (Boot Device Switch)
4	449-0763	Cover, Front Panel
5*	725-0269	Winchester Disk Drive, 145 MB
6	458-3339	Housing, Winchester Drive
7*	270-1082	Power Supply, Switching

* = Field Replaceable Item

►NEXT

12.2 ILLUSTRATED PARTS

Subassemblies

12.2.2 VS-75E Computer Chassis (Sheet 2 of 2)

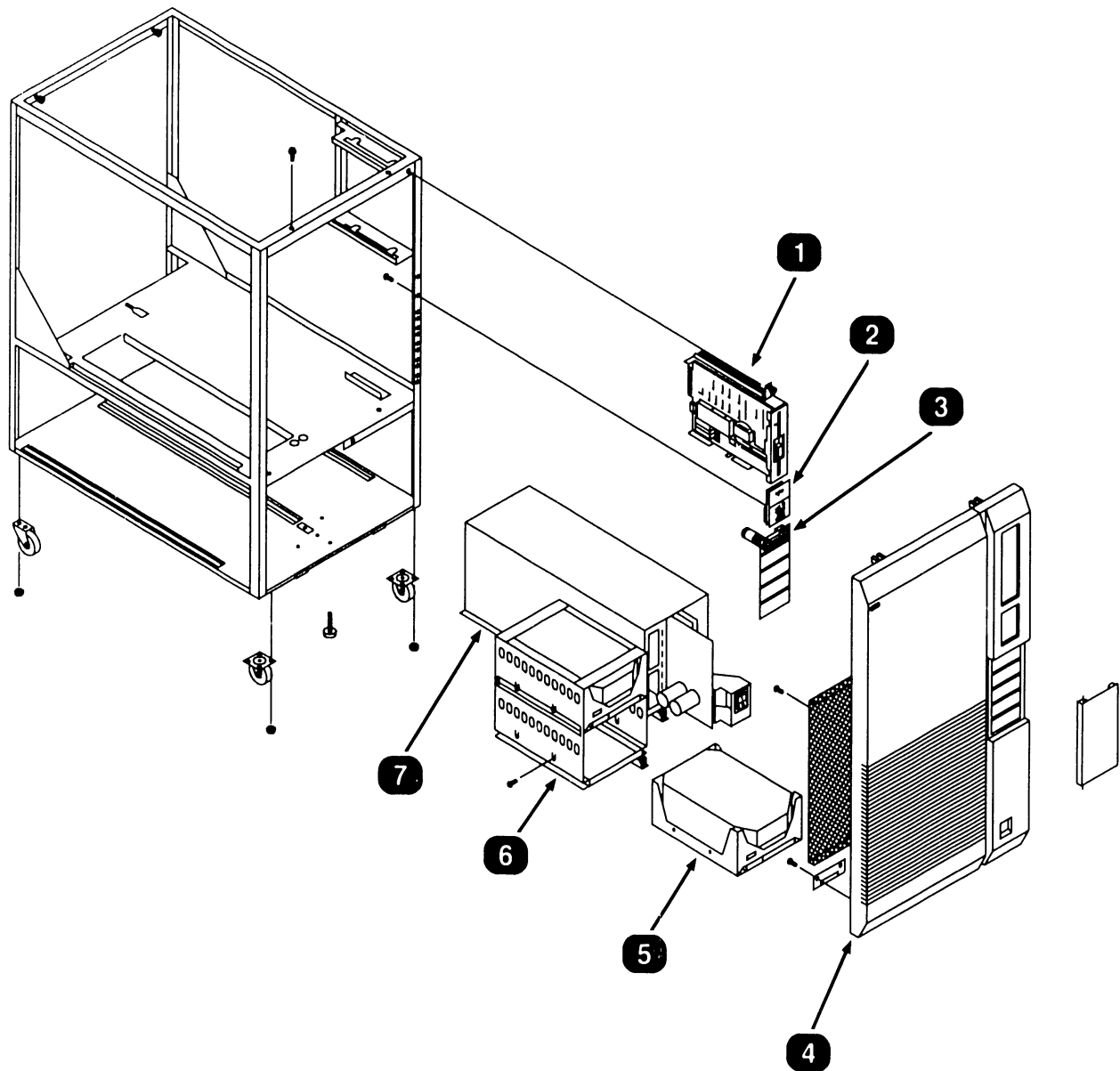

● END

12.2 **ILLUSTRATED PARTS**

Subassemblies

12.2.3 VS-75E Computer Card Cage (Sheet 1 of 2)

<i>Item</i>	<i>Part Number</i>	<i>Description</i>
1*	210-9094-A	Main Memory Board, 2 MB
	210-9094-1A	Main Memory Board, 4 MB
	210-9094-2A	Main Memory Board, 8 MB
2*	210-9699-A	CPU Board
3*	210-9095-A	Bus Processor Board
4*		Optional Controller Boards
	210-9416-A	4-Port High Speed SMD DA
	210-9337-A	1-Port TC DA
	210-9637-A	2-Port TC DA
	210-9355-A	Aysnc Device Controller
	210-8647-A	UISIO DA
	210-8614	RSF Controller
5	452-0370	PC Holddown
6	451-2640	Cover, DC Voltage Bus
7*	210-9065	Motherboard
8*	220-3435	Cable, Main Memory to CP

* Field Replaceable Item

►NEXT

12.2 ILLUSTRATED PARTS

Subassemblies

12.2.3 VS-75E Computer Card Cage (Sheet 2 of 2)

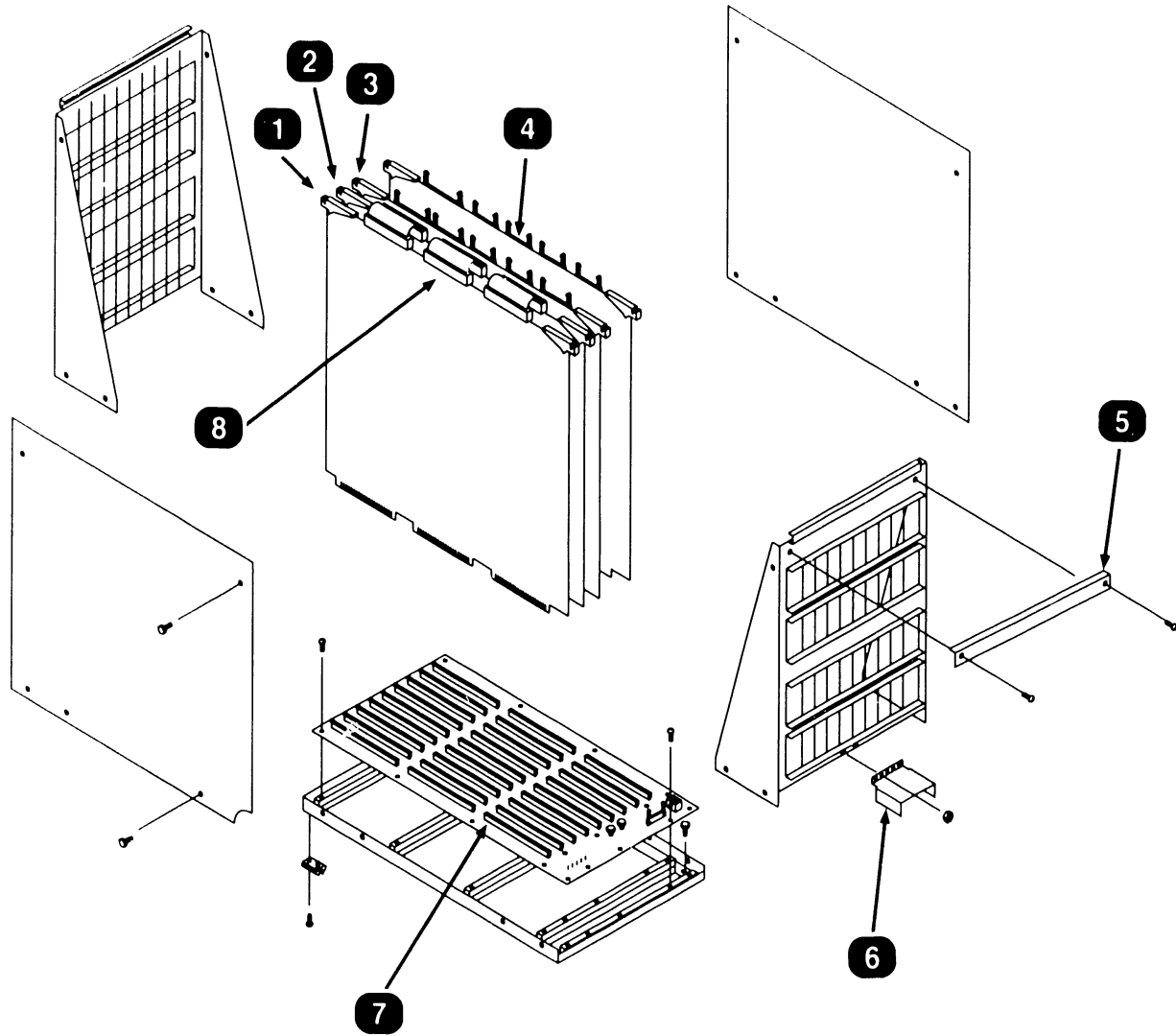

● END

12.2

Subassemblies

ILLUSTRATED PARTS

12.2.4 VS-75E Rear Panel Assembly (Sheet 1 of 2)

<i>Item</i>	<i>Part Number</i>	<i>Description</i>
1	270-1085	SCSI I/O Panel
1a*	220-3598	Cable, 50 Pos. Soc-Soc, D-Face (SCSI Bus)
1b*	220-3599	Cable, 25 Pos. D-Sub (PTRB)
1c*	220-3591	Cable, Dual 25 Pos. D-Sub (Remote/PTRA)
1d*	725-3334	Terminator, 50 Pin (SCSI Bus)
2*	270-0975	EAPA Panel
2b*	220-2346	Cable; Power Jumper, 3-Pin Soc-Soc
2a*	220-3319	Cable; Signal Jumper, 34-Pin Soc-Soc
2c*	210-8503	PCA, Terminator
3	478-1202 or	Panel, I/O Blank (Half) Option Panel:
	272-0048	Panel, Async
	272-0051	Panel, TC Single Port
	272-0052	Panel, TC Dual Port
	272-0054	Panel, 4-Port SMD
	270-1055	Panel Assembly, RSF (includes Cable 220-3469 and terminator 210-8172)

* Field Replaceable Item

▶ NEXT

12.2

Subassemblies

ILLUSTRATED PARTS

12.2.4 VS-75E Rear Panel Assembly (Sheet 2 of 2)

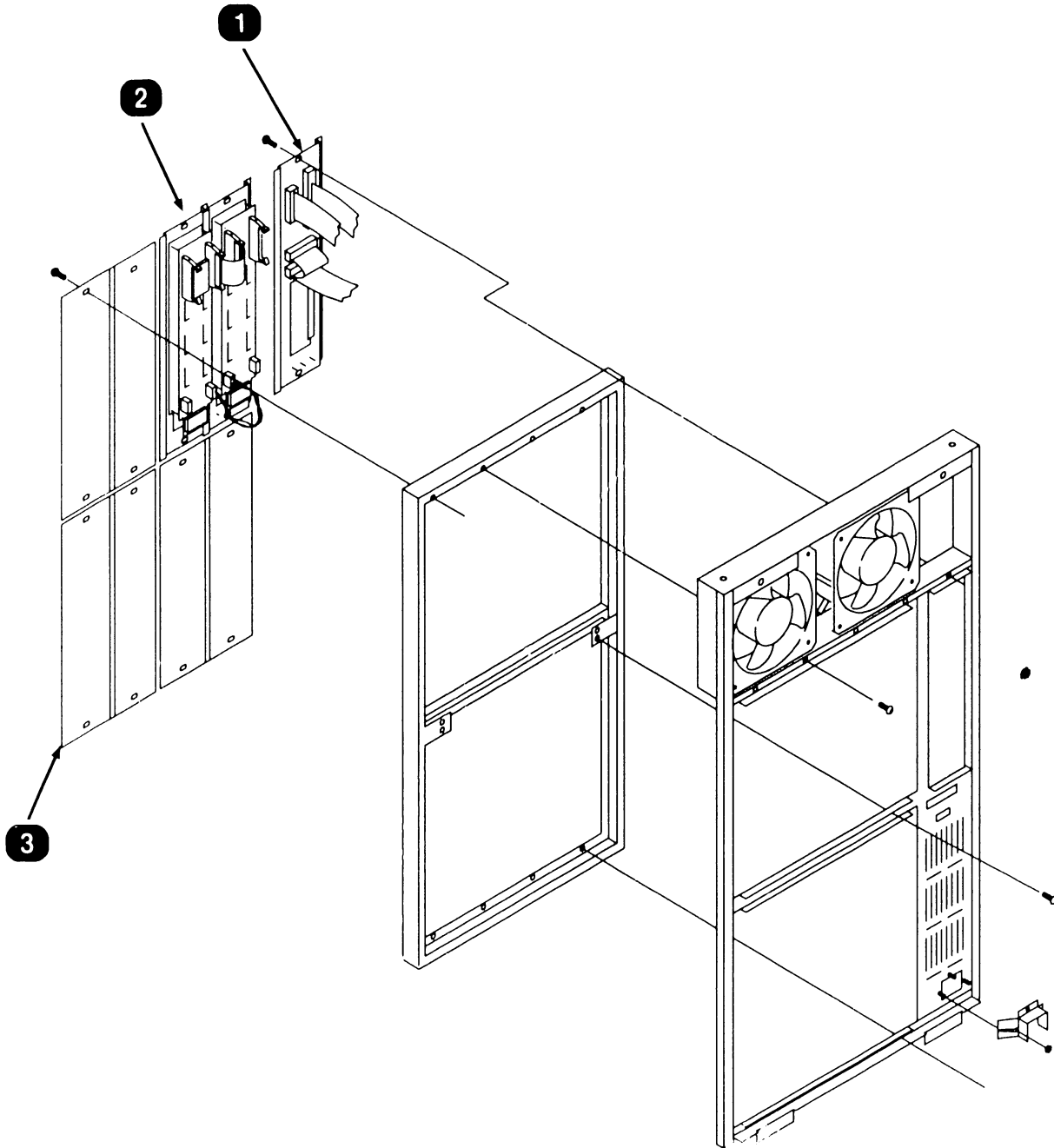

● END

12.3 VS-75E Interconnect Diagram (Sheet 1 of 2)

ILLUSTRATED PARTS

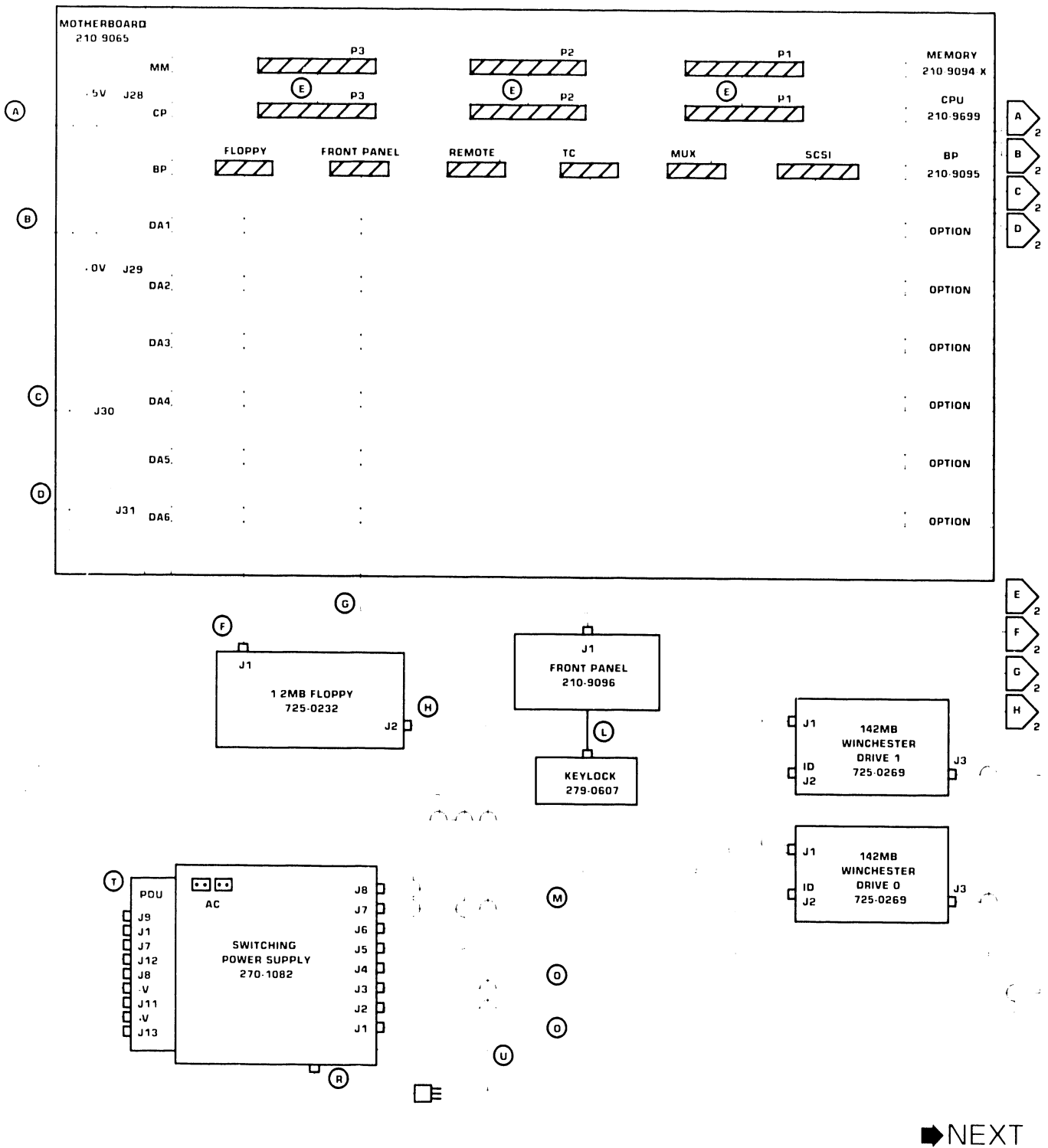

12.3 VS-75E Interconnect Diagram (Sheet 2 of 2)

ILLUSTRATED PARTS

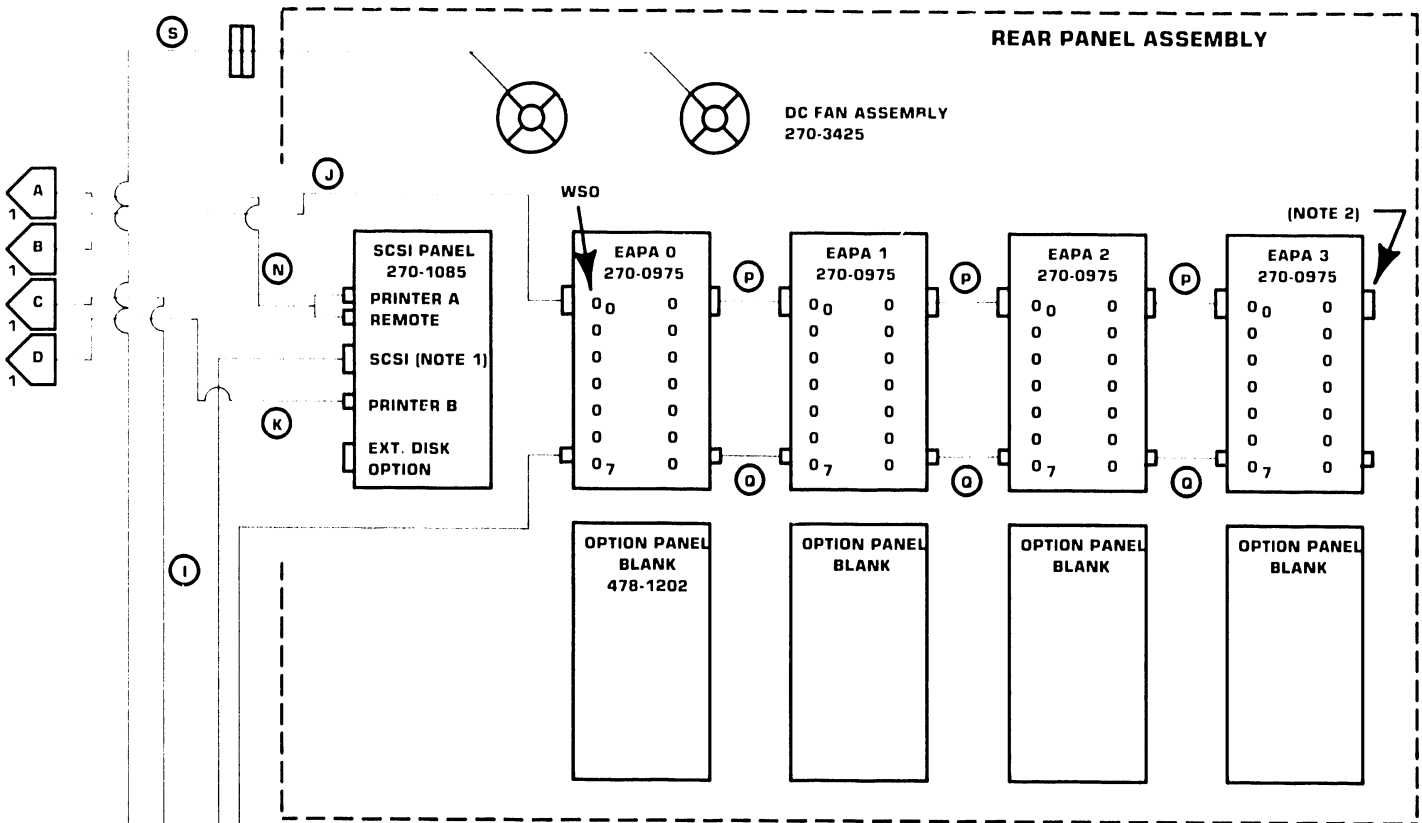

NOTES

1. Last SCSI Device in Chain Must Be Terminated. If None, SCSI Port Must Be Terminated Using Terminator Part Number 725-3334.
2. Last EAPA In Chain Must Be Terminated Using Terminator Part Number 210-8503.
3. Memory PCA 210-9094-X can be either
 210-9094-A - 2MB
 210-9094-1A - 4MB
 210-9094-2A - 8MB

ITEM	PART NO.	CABLE DESCRIPTION
------	----------	-------------------

A	220-2628	SPS +5V TO MOTHERBOARD J28 (+5V)
B	220-2627	SPS +0V TO MOTHERBOARD J29 (+0V)
C	220-3193	SPS J8 TO MOTHERBOARD J30
D	220-0407	SPS J5 TO MOTHERBOARD J31
E	220-3435	MAIN MEMORY TO CP P1, P2, P3
F	220-3611	BP FLOPPY TO FLOPPY J1
G	220-3592	BP FRONT PANEL TO FRONT PANEL J1
H	220-0405	SPS J1 TO FLOPPY POWER CONNECTOR J2
I	220-3598	BP SCSI TO WINCHESTER/SCSI PORT
J	220-3396	BP MUX TO EAPA 0
K	220-3599	BP TC TO SCSI PANEL REMOTE
L	220-2121	KEYLOCK TO FRONT PANEL
M	220-2555	SPS J7 TO EAPA 0 POWER CONNECTOR
N	220-3417	BP REMOTE TO PRINTER A/REMOTE
O	220-2554	SPS J2/J3 TO WINCHESTER DRIVES
P	220-3319	EAPA SIGNAL JUMPER
Q	220-2346	EAPA POWER JUMPER
R	420-2040	AC POWER CORD TO PS
S	220-2553	PDU J12 TO DC FANS
T	220-2533	SPS J6 TO PDU J9
U	220-2116	SPS GND TO CHASSIS GND

SCSI DRIVE ADDRESS	J2 JUMPERS		
	(4) ID2	(2) ID1	(1) ID0
6	IN	IN	OUT
5	IN	OUT	IN
4	IN	OUT	OUT
3	OUT	IN	IN

● END

12.4 CABLE ASSEMBLIES

ILLUSTRATED PARTS

12.4.1 Standard Cable Assemblies

<i>Cable P/N</i>	<i>Source</i>	<i>Destination</i>
420-2040	AC Power Receptacle	SPS Power Supply AC Connector
220-2628	Power Supply +5V Bus	Motherboard +5V Bus
220-2627	Power Supply +0V Bus	Motherboard +0V Bus
220-3193	SPS J8	Motherboard J30
220-0407	SPS J5	Motherboard J31
220-0405	SPS J1	Floppy Power Connector (J2)
220-2555	SPS J7	EAPA 0 Power Connector (J3)
220-2554	SPS J2/J3	Winchester Drive(s) Power Connector
220-2553	SPS PDU J12	DC Fan Assembly
220-2533	SPS J6	PDU J9
220-2116	Chassis Ground	SPS Spade Lug
220-3611	BP Floppy Connector	Floppy Drive (J1)
220-3592	BP Front Panel Connector	Front Panel
220-3417	BP Remote Connector	SCSI I/O Panel Ptr A/ Remote Port
220-3599	BP TC Connector	SCSI I/O Panel Printer B Port
220-3396	BP MUX Connector	EAPA 0 (J1)
220-3598	BP SCSI Connector	Winchester (S)/SCSI Port
220-3435	9699-A CPU (P1,P2,P3)	9094 Memory Board (P1, P2, P3)
220-3319	EAPA 0 Signal-Out (J2)	EAPA 1 Signal-In (J1)
220-2346	EAPA 0 Power (J4)	EAPA 1 Power (J3)

● END

12.4 CABLE ASSEMBLIES

ILLUSTRATED PARTS

12.4.2 Optional Cable Assemblies

<i>Cable P/N</i>	<i>Source</i>	<i>Destination</i>
220-3546	SMD Connector J1	External Drive Data 'A' Cable
220-3544	SMD Connector J2	External Drive 0 'B' Cable
220-3544	SMD Connector J3	External Drive 1 'B' Cable
220-3545	SMD Connector J4	External Drive 2 'B' Cable
220-3545	SMD Connector J5	External Drive 3 'B' Cable
220-3001	2-Port TC DA (S2)	Light Board PCA (J1)
220-3002	2-Port TC DA (S1)	Light Board PCA (J1)
220-3539	2-Port TC DA (J2B, J3B)	RS232 Connector, RS366 Connector
220-3540	2-Port TC DA (J2A, J3A)	RS232 Connector, RS366 Connector
220-3541	2-Port TC DA (J13A/B)	X.21 Connector
220-3556	1-Port TC DA (J4)	Light Board PCA (J1)
220-3539	1-Port TC DA (J2, J3)	RS232 Connector, RS366 Connector
220-3541	1-Port TC DA (J13)	X.21 Connector
220-3542	Async Controller (J3, J4)	Async Panel Connectors (J3, J4)
220-3543	Async Controller (J1, J2)	Async Panel Connectors (J1, J2)

● END



LABORATORIES, INC

ONE INDUSTRIAL AVENUE, LOWELL, MASSACHUSETTS 01851, TEL. (617) 459-5000, TWX 710 343-6769, TELEX 94-7421

PRINTED IN U.S.A.

COMPANY CONFIDENTIAL

END