

P R E L I M I N A R Y C O P Y / N O N - V E R I F I E D

WANG

V S - 7 0 1 0 C O M P U T E R S Y S T E M
S P E C I A L F I E L D S U P P O R T

C u s t o m e r E n g i n e e r i n g
P r o d u c t M a i n t e n a n c e M a n u a l

C O M P A N Y C O N F I D E N T I A L

P R E L I M I N A R Y C O P Y / N O N - V E R I F I E D

PREFACE

This document is a Preliminary Product Maintenance Manual (PMM) for the Wang VS-7010 Computer System. The manual is organized in accordance with Customer Engineering Technical Documentation's approved PMM outline. The scope of this manual reflects the type of maintenance philosophy selected for this product.

The purpose of this manual is to provide the Wang-trained Customer Engineer (CE) with sufficient instructions to operate, troubleshoot, and repair the VS-7010 Computer System. The manual will be updated on a regular schedule or as necessary. Such updates will be published either as Publication Update Bulletins (PUBs) or as full revisions.

First Edition (October, 1987)

Use of the material in this document is authorized only for the purpose stated in the Preface, above.

© Copyright 1987, Wang Laboratories, Inc.

WARNING

DO NOT OPEN THE SWITCHING POWER SUPPLY UNDER ANY CIRCUMSTANCE. EXTREMELY DANGEROUS VOLTAGE AND CURRENT LEVELS, IN EXCESS OF 300 VOLTS DC AND UNLIMITED CURRENT, ARE PRESENT WITHIN THE POWER SUPPLY.

DO NOT ATTEMPT TO REPAIR THE POWER SUPPLY; IT IS FIELD REPLACEABLE ONLY.

AFTER POWERING THE UNIT DOWN AND DISCONNECTING THE AC POWER PLUG FROM THE WALL OUTLET, ALLOW ONE MINUTE BEFORE REMOVING THE POWER SUPPLY TO PROVIDE ADEQUATE TIME FOR ANY RESIDUAL VOLTAGE TO DRAIN THROUGH THE BLEEDER RESISTORS.

WARNING

THIS COMPUTER EQUIPMENT HAS BEEN VERIFIED AS FCC CLASS A.

IN ORDER TO MAINTAIN COMPLIANCE WITH FCC CLASS A VERIFICATION, THE FOLLOWING CONDITIONS MUST BE ADHERED TO DURING NORMAL OPERATION OF EQUIPMENT.

- ALL COVERS MUST BE ON THE SYSTEM AND SECURED IN THE PROPER MANNER.
 - ALL INTERNAL CABLES MUST BE ROUTED IN THE ORIGINAL MANNER WITHIN THE CABLE CLAMPS PROVIDED FOR THAT PURPOSE.
 - ALL EXTERNAL CABLES MUST BE SECURED AND THE PROPER CABLE USED TO ENSURE THAT CABLE SHIELDING IS PROPERLY GROUNDED TO THE CABLE CLAMPS PROVIDED.
 - ALL HARDWARE MUST BE PROPERLY SECURED.
-

SECTION 1 INTRODUCTION

	<u>Page</u>
1.1	Scope And Purpose 1-1
1.2	Organization And Layout 1-2
1.3	Related Documentation 1-3
1.4	Abbreviations And Symbols Used In This Manual 1-4

SECTION 2 IDENTIFICATION

	<u>Page</u>
2.1	Major Assemblies 2-1
2.1.1	System Components 2-1
2.2	VS-7010 Computer Major Parts (Front View) 2-2
2.3	VS-7010 Computer Major Parts (Rear View) 2-3
2.4	VS-7010 Card Cage Major Parts 2-4
2.5	Support Control Unit (PC) Major Parts (Front View) 2-5
2.6	Support Control Unit (PC) Major Parts (Rear View) 2-6

SECTION 3 CONTROLS AND INDICATORS

Page

Section 3 is not included in the preliminary manual.

SECTION 4 OPERATION

		<u>Page</u>
4.1	Power-Up And B.I.T. Diagnostic Procedure	4-1
4.2	Power-Down Procedure	4-13

SECTION 5 PREVENTIVE MAINTENANCE

		<u>Page</u>
5.1	Materials Required	5-1
5.2	PM Schedules	5-2
5.3	Operational Check	5-3
5.4	Cleaning	5-4
5.5	Inspection	5-5
5.6	Adjustments	5-6

SECTION 6 TROUBLESHOOTING

		<u>Page</u>
6.1	TOOLS AND EQUIPMENT	6-1
6.1.1	Special Tools	6-2
6.2	OFF-LINE DIAGNOSTICS	6-3
6.2.1	Power-Up Diagnostics	6-4
6.2.2	Accessing DCS Diagnostics	6-5
6.2.3	Running DCS Diagnostics	6-10

SECTION 7 REPAIR		Page
7.1	Tools And Test Equipment	7-1
7.2	Removal Procedures	7-2
7.2.1	Top Cover Removal	7-2
7.2.2	Front Cover Removal	7-3
7.2.3	Side Covers Removal	7-4
7.2.4	Card Cage Cover Removal	7-5
7.2.5	General PCB Removal	7-6
7.2.6	Central Processing Unit (CPU) Removal	7-8
7.2.7	Address Generation Unit (AGU) Removal.....	7-10
7.2.8	Address Translation Unit (ATU) Removal	7-12
7.2.9	Support Control Unit (SCU) Removal	7-14
7.2.10	Memory Control Unit (MCU) Removal	7-15
7.2.11	Main Memory (MEM) Board (210-8307/-1) Removal	7-17
7.2.12	Main Memory (MEM) Board (210-9874/-1) Removal	7-19
7.2.13	System Bus Interface (SBI) Removal	7-21
7.2.14	SMD Controller (23V98-4) IOC Removal	7-23
7.2.15	Serial Controller (23V67) IOC Removal	7-26
7.2.16	Kennedy Tape (23V95-1) IOC Removal	7-28
7.2.17	Telex Tape (23V95-2) IOC Removal	7-30
7.2.18	Multiline TC (23V86/96) IOC Removal	7-32
7.2.19	Power Supply Controller Removal	7-34
7.2.20	DC Power Distribution Unit (PDU) Removal	7-37

SECTION 8 ADJUSTMENTS

	<u>Page</u>
8.1	Tools And Equipment 8-1
8.1.1	Special Tools 8-1
8.2	Electrical Adjustments 8-2
8.2.1	Multioutput Power Supply Voltage Adjustments 8-2
8.2.2	Power Supply Controller Adjustments 8-6

SECTION 9 UNPACKING AND SETUP

	<u>Page</u>
9.1	Installation Site Check 9-1
9.2	Tools And Equipment 9-2
9.3	Unpacking Procedures 9-3
9.3.1	Unpacking And Inspecting VS-7010 Computer System 9-3
9.3.2	Unpacking And Inspecting SCU Professional Computer 9-5
9.3.3	Unpacking And Inspecting SCU (PM-004L) Moniotr 9-6
9.3.4	Unpacking And Inspecting SCU (720) Keyboard 9-7
9.3.5	Unpacking Peripherals 9-8
9.3.6	Claims Information 9-9
9.3.7	Initial Set-Up 9-10
9.4	Inspection 9-11
9.4.1	VS-7010 Mainframe Inspection 9-11
9.4.2	Peripheral Inspection 9-13
9.4.3	VS-7010 Power Service Requirements (Domestic) 9-14

SECTION 10 FUNCTIONAL DESCRIPTIONPage

Section 10 is not included in the preliminary manual.

SECTION 11 SPECIFICATIONS

	<u>Page</u>
11.1	Hardware 11-1
11.1.1	VS-7010 Mainframe 11-1
11.1.2	VS-7010 Architecture 11-2
11.1.3	Multioutput Power Supply Specifications 11-3
11.2	Operating System Software 11-4
11.3	Diagnostics 11-5
11.3.1	Built-In-Test 11-5
11.3.2	Diagnostics 11-6

SECTION 12 ILLUSTRATED PARTS

	<u>Page</u>
12.1	Major Assemblies 12-1
12.2	VS-7010 Subassemblies 12-2
12.2.1	VS-7010 Computer System Covers 12-2
12.2.2	VS-7010 Computer Chassis 12-4
12.2.3	VS-7010 Computer Card Cage 12-6
12.2.4	VS-7010 Rear Panel Assembly 12-8
12.3	Support Control Unit (SCU) Subassemblies 12-10
12.3.1	SCU Professional Computer 12-10
12.3.2	SCU Monitor 12-12
12.4	VS-7010 Interconnection Diagram 12-14
12.5	Cable Assemblies 12-16
12.5.1	Standard Cable Assemblies 12-16
12.5.2	Optional Cable Assemblies 12-17

SECTION

1

INTRODUCTION

SECTION 1
INTRODUCTION

	<u>Page</u>
1.1 SCOPE AND PURPOSE	1-1
1.2 ORGANIZATION AND LAYOUT	1-2
1.3 RELATED DOCUMENTATION	1-3
1.4 ABBREVIATIONS AND SYMBOLS USED IN THIS MANUAL	1-4

1.1 Scope And Purpose

This manual contains installation, operation, troubleshooting, and repair information for the VS-7010 Computer System, a full function VS system with multi-user DP and WP capabilities. This manual also contains a functional description of the VS-7010 and an illustrated breakdown of replaceable parts.

The purpose of the manual is to provide Customer Engineering personnel with the information necessary to install, troubleshoot, and repair any model of the VS-7010 in the field. Familiarity with large VS systems (7110, 7120 and 7150) is recommended for effective use of this manual.

1.2 Organization And Layout

This manual is divided into 12 sections numbered 1 through 12. Each section describes a separate maintenance subject and is arranged to minimize references to other sections. Referencing to other frames is made by means of an arrow (→) followed by the section number(s) being referenced.

All or most information pertaining to a specific task is located on a single and/or double frame. Each frame contains illustrations, numbered steps, and/or text describing the individual steps required to accomplish each task. The steps within a frame are numbered in sequence in a clockwise direction around the various illustrations. Each section is preceded by the section number and a section table of contents. The sections and corresponding frames are arranged in numerical sequence from left-to-right and from top-to-bottom on the individual fiche cards.

1.3 Related Documentation

Document	Part Number
Professional Computer	741-1190
PM-004L Monochrome Monitor	741-1647
VS Test On-Line Test Package	741-1767
VS-300 Diagnostic Handbook	741-1742
VS-300 Service Handbook	741-1711
VS-7100 Computer System	741-1721

1.4 Abbreviations And Symbols Used In This Manual (Sheet 1 of 2)

ABBREVIATION/ SYMBOL	DEFINITION
A/D	Analog-to-Digital
AC	Alternating current
AGU	Address Generation Unit
ATU	Address Translation Unit
ANSI	American National Standards Institute
APA	Active Port Assembly
ASSY	Assembly
BIT	Built In Test
BPI	Bits Per Inch
CBL	Cable
CC	Cable Concentrator
CM	Control Mode
CMD	Cartridge Module Drive
CP	Central Processor
CPU	Central Processing Unit
DC	Direct Current
DCS	Diagnostic Control System
DIP	Dual In-line Package
DISKEX	Disk Exerciser
DOS	Disk Operating System
DRAM	Data Random Access Memory
DVM	Digital Voltmeter
EAPA	Electrically Active Port Assembly
ECC	Error Correction Code
EIA	Electronic Industries Association
EOT	End Of Tape
FCC	Federal Communications Commission
FMD	Fixed Module Drive
FRU	Field-Replaceable Unit
GATC	Gate Array Telecommunications
HEX	Hexidecimal Notation (H)
I/O	Input/Output
IOC	Input/Output Controller
IOP	Input/Output Processor
IOSW	Input/Output Status Word
IPB	Illustrated Parts Breakdown
IPC	Interprocessor Communications
IPL	Initial Program Load
KG	Kilogram
LED	Light-Emitting Diode
M	Mega, (Million)
MBPS	Megabits Per Second
MCU	Memory Control Unit
MLTC	Multiline Telecommunications
MM	Main Memory
MODEM	Modulator/Demodulator
NEMA	National Electrical Manufacturers Association

1.4 Abbreviations And Symbols Used In This Manual (Sheet 2 of 2)

ABBREVIATION/ SYMBOL	DEFINITION
NRZI	Nonreturn to Zero
OS	Operating System
P-BAND	Peripheral Band
P/N	Part Number
PC (SCU)	Professional Computer (Support Control Unit)
PCA	Printed Circuit Assembly
PDA	Physical Device Address
PDU	Power Distribution Unit
PE	Phase Encode
PF	Program Function
PM	Preventive Maintenance
PREX	Printer Exerciser
RAM	Random Access Memory
RF	Radio Frequency
RSAF	Remote System Administrative Facility
RSD	Removable Storage Drive
SBI	System Bus Interface
SCU (PC)	Support Control Unit (Professional Computer)
SCUI	Support Control Unit Interface
SMD	Storage Module Drive
SPB	Support Packet Bus
SPS	Switching Power Supply
SQB	Status Qualifier Byte
SVC	Supervisor Call
SW	Switch
SYSGEN	System Generation
TAC	Technical Assistance Center
TC	Telecommunications
TP	Test Point
TPEX	Tape Exerciser
V	Volts
VS	Virtual Storage
VTOC	Volume Table Of Contents
WS	Workstation
WLI P/N	Wang Laboratories, Inc. Part Number
WSEX	Workstation Exerciser

SECTION

2

IDENTIFICATION

SECTION 2
IDENTIFICATION

	<u>Page</u>
2.1 MAJOR ASSEMBLIES	2-1
2.1.1 System Components	2-1
2.2 VS-7010 Computer Major Parts (Front View)	2-2
2.3 VS-7010 Computer Major Parts (Rear View)	2-3
2.4 VS-7010 Card Cage Major Parts	2-4
2.5 Support Control Unit (PC) Major Parts (Front View)	2-5
2.6 Support Control Unit (PC) Major Parts (Rear View)	2-6

2.1 Major Assemblies

2.1.1 System Components

VS-7010 Computer

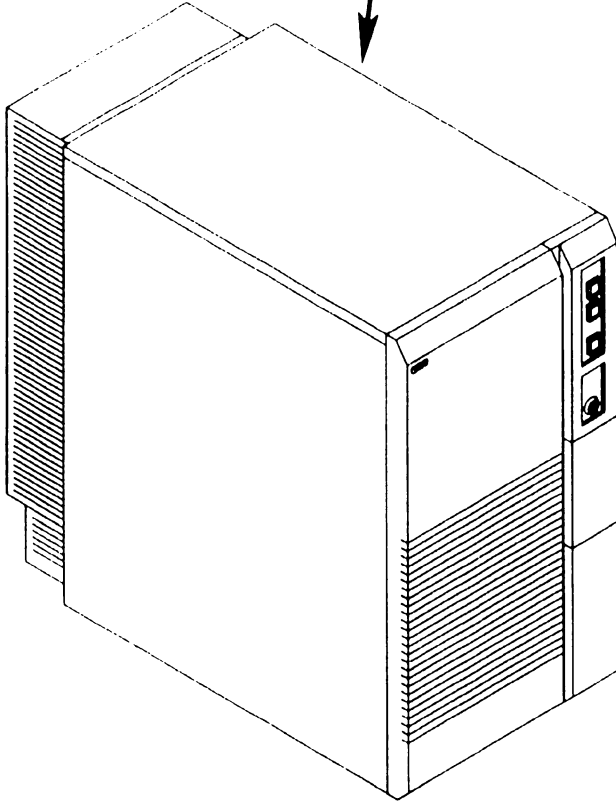

SCU (PM-004L) Monitor

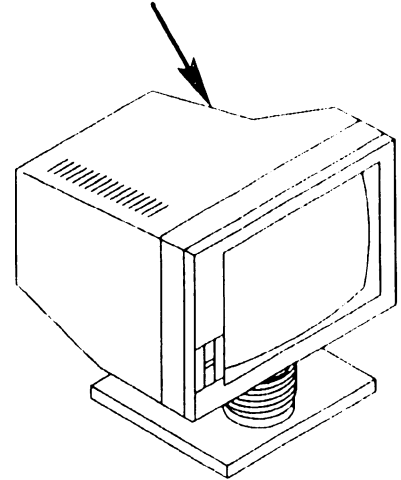

Support Control Unit
(Professional Computer)

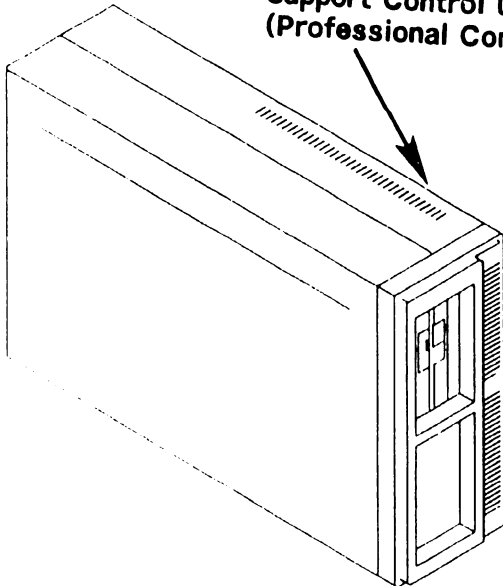

SCU (720) Keyboard

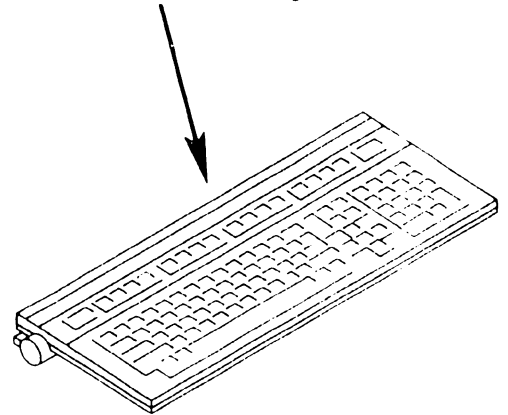

2.2 VS-7010 Computer Major Parts (Front View)

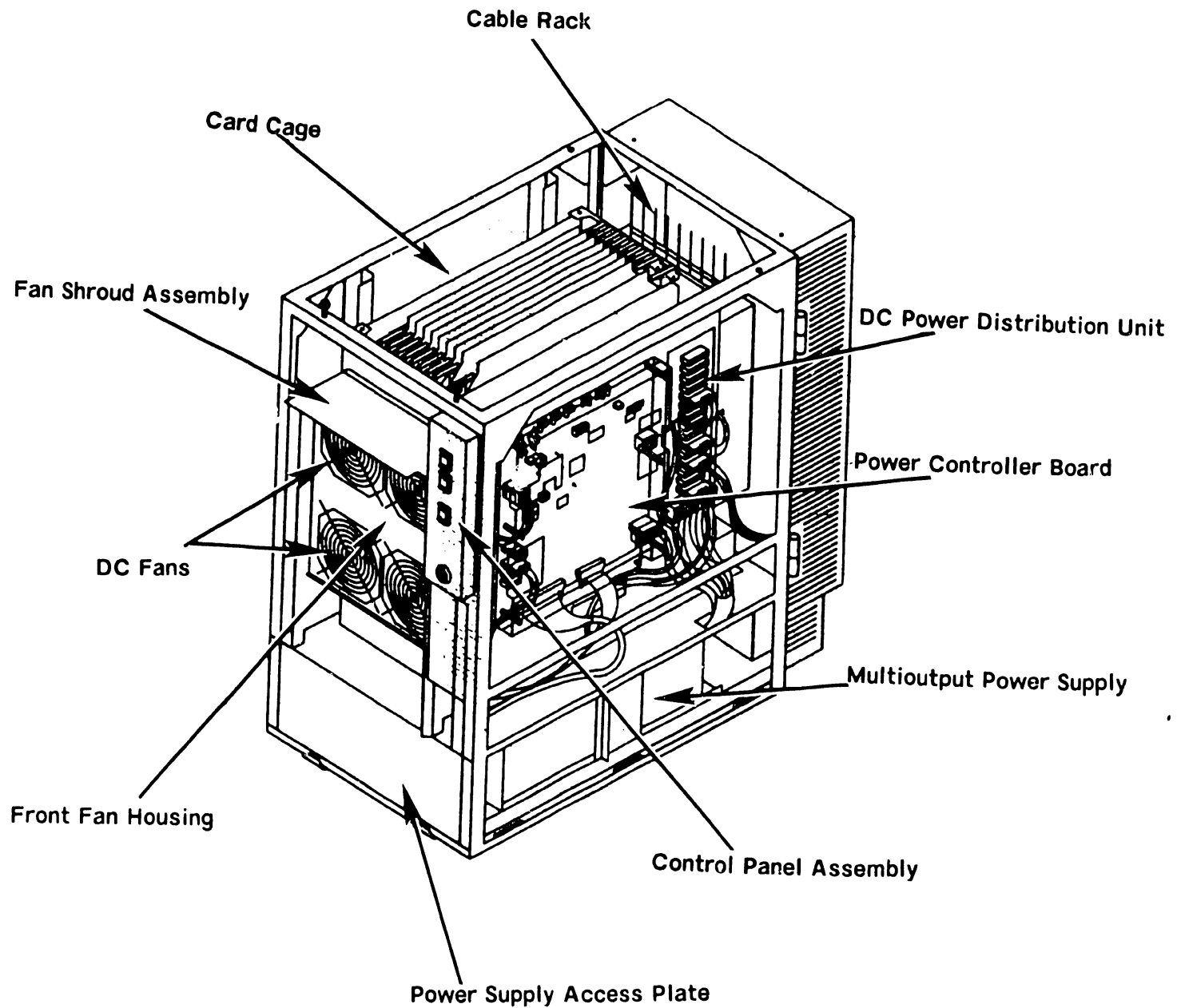

2.3 VS-7010 Computer Major Parts (Rear View)

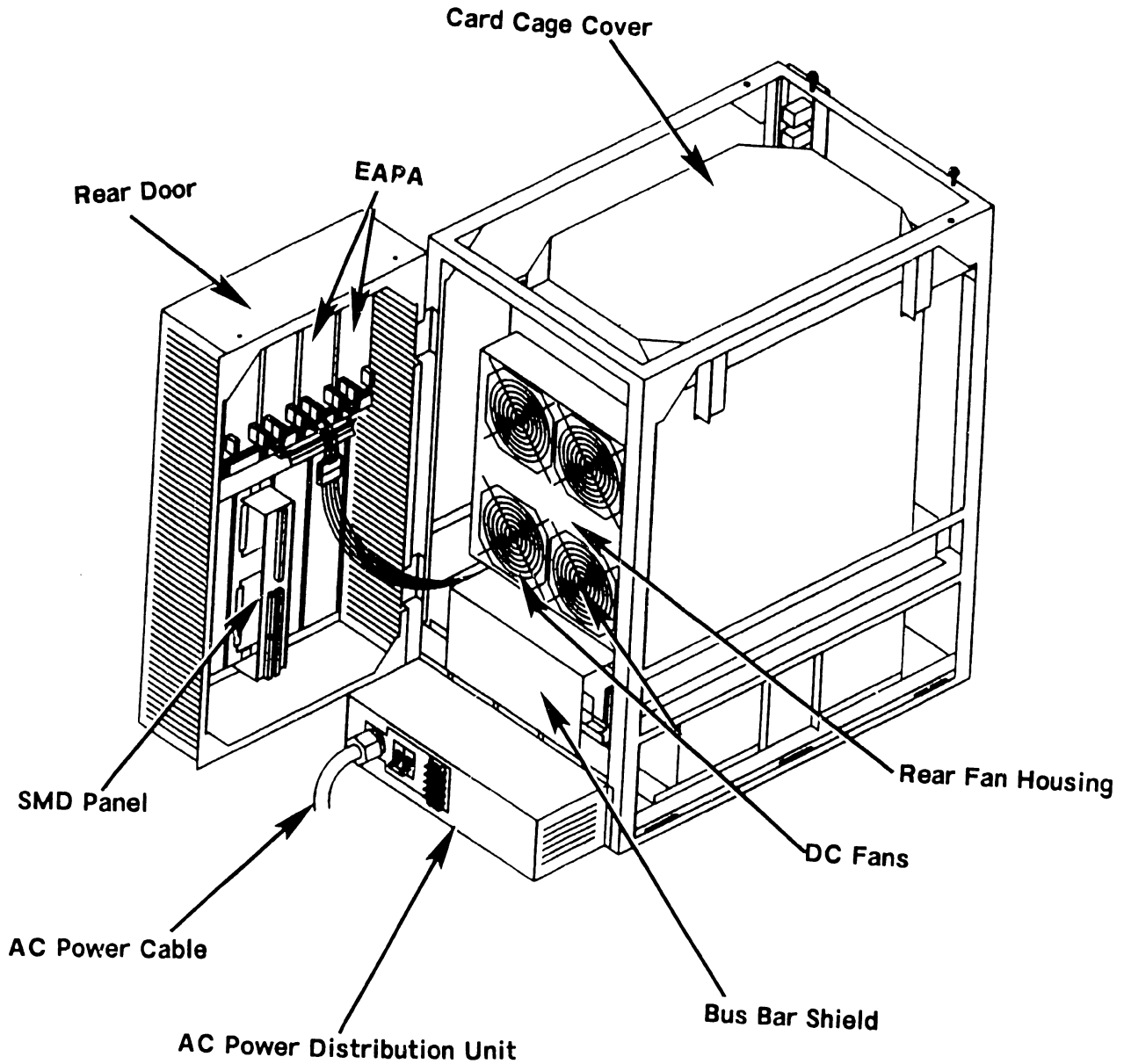

2.4 VS-7010 Card Cage Major Parts

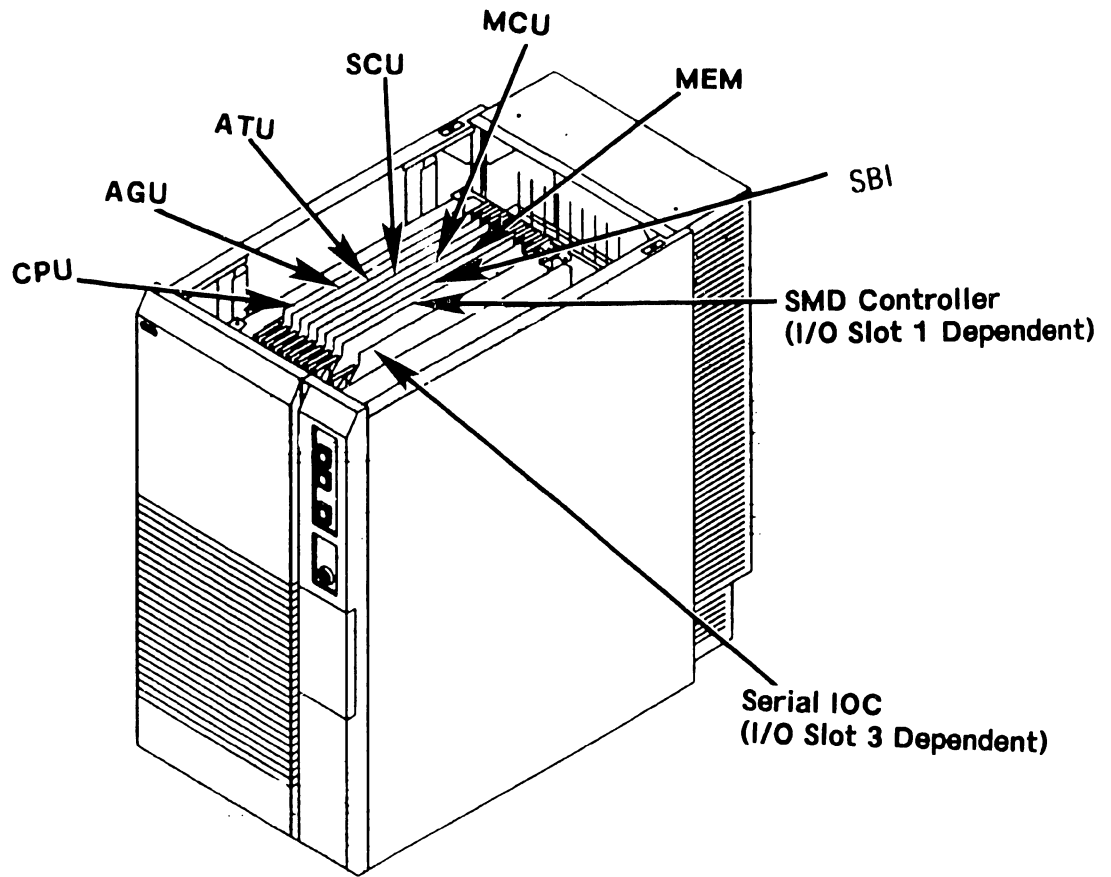

2.5 Support Control Unit (PC) Major Parts (Front View)

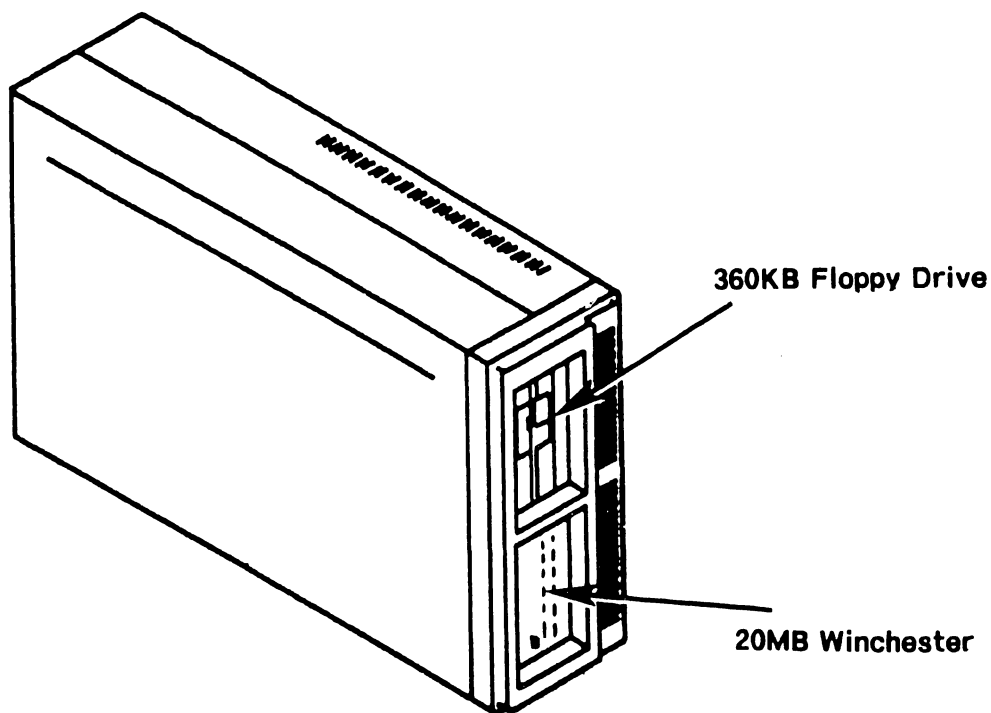

2.6 Support Control Unit (PC) Major Parts (Rear View)

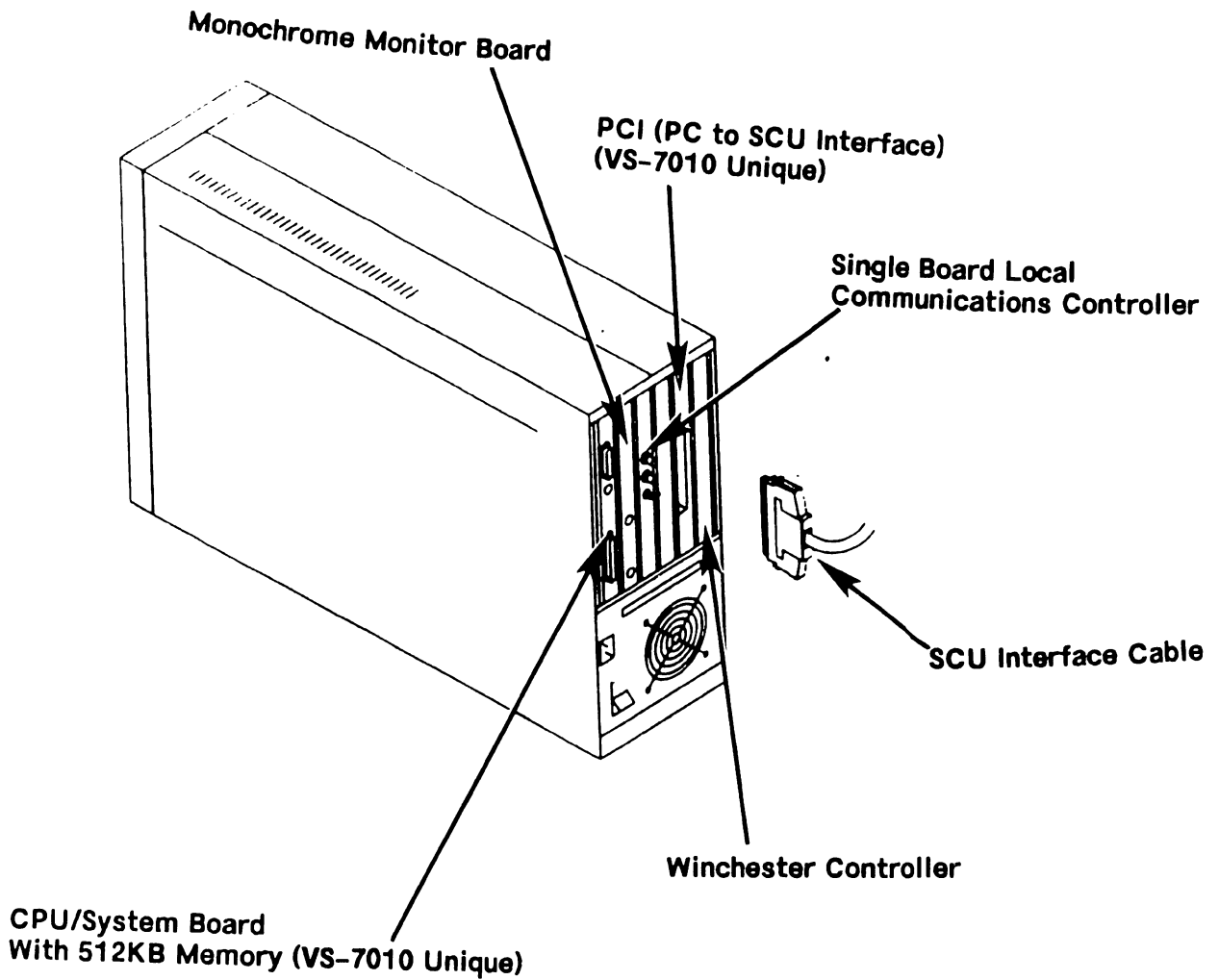

SECTION

3

**CONTROLS AND
INDICATORS**

SECTION 3 CONTENTS

SECTION 3 CONTROLS AND INDICATORS

This section is not included in the Preliminary
VS-7010 Computer System manual.

SECTION

4

OPERATION

SECTION 4
OPERATION

		<u>Page</u>
4.1	POWER-UP AND B.I.T. DIAGNOSTIC PROCEDURE	4-1
4.2	POWER-DOWN PROCEDURE	4-13

4.1 Power-on and B.I.T. Diagnostic Procedure (Sheet 1 of 14)

CAUTION

Improper power-on procedure may damage disk and tape drives Volume Table Of Contents (VTOC). Perform power-on procedures as follows.

- 1) Power-on all workstations and printers.
- 2) Position all external drives ac On/Off circuit breakers to the On position.
- 3) Position mainframe ac On/Off circuit breaker to the On position.

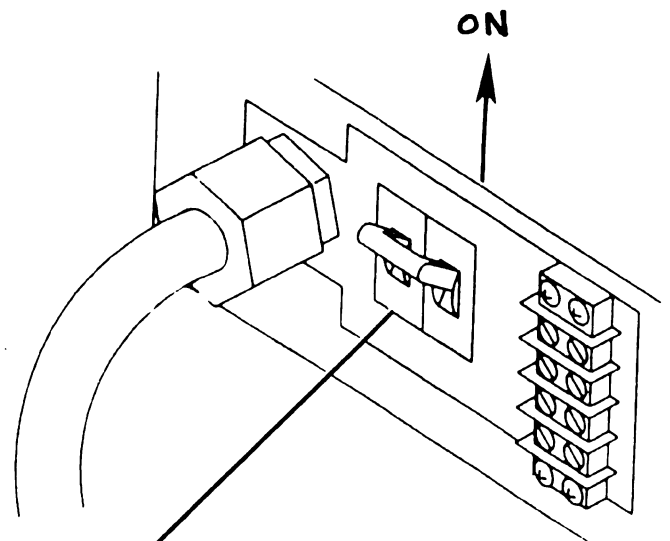
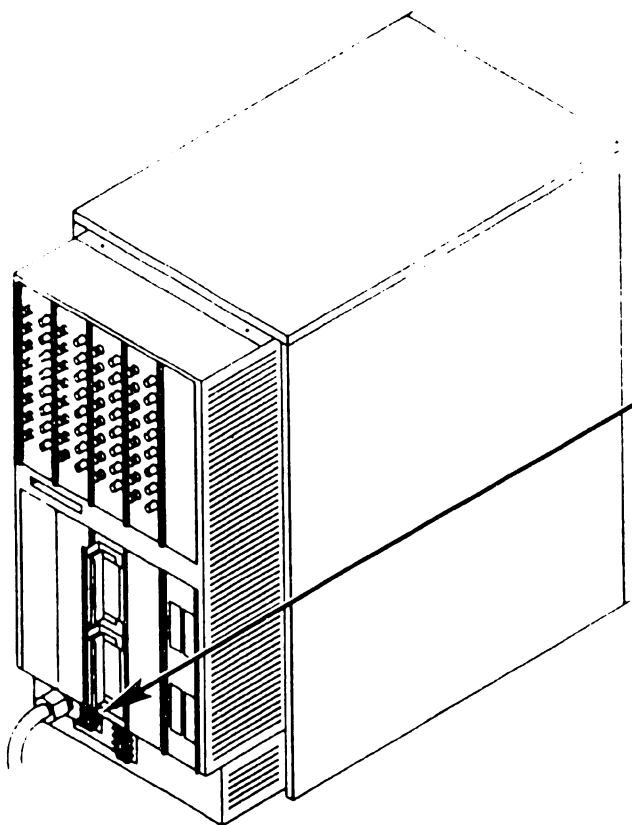

4.1 Power-on and B.I.T. Diagnostic Procedure (Sheet 2 of 14)

- 4) Position control panel keyswitch to 'Normal Control' position.
- 5) Power-on mainframe by pressing control panel ON pushbutton.

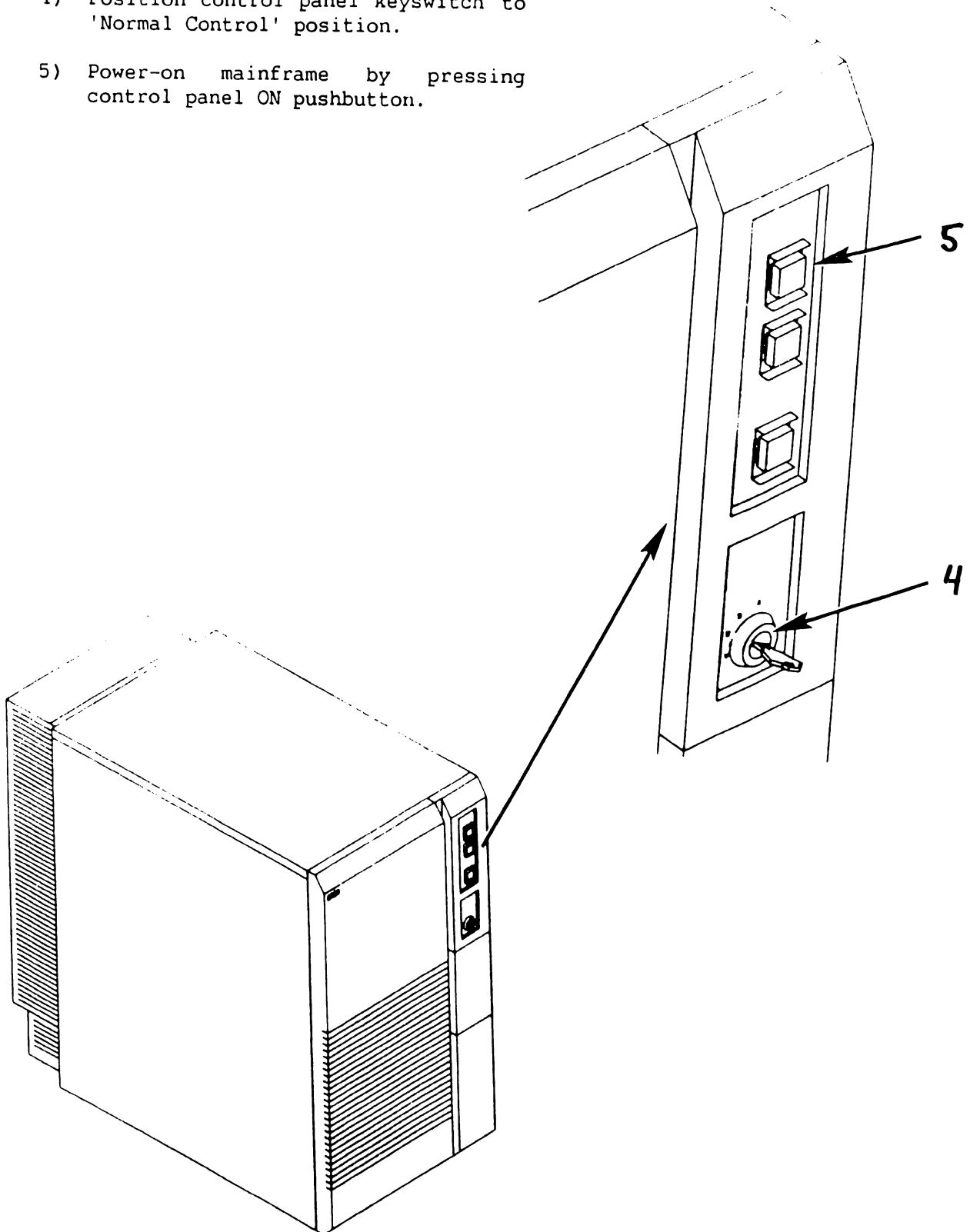

4.1 Power-on and B.I.T. Diagnostic Procedure (Sheet 3 of 14)

- 6) Power-on SCU (PC) by pressing ac On/Off power switch to the On (1) position.
- 7) 'READY' external disk drives.

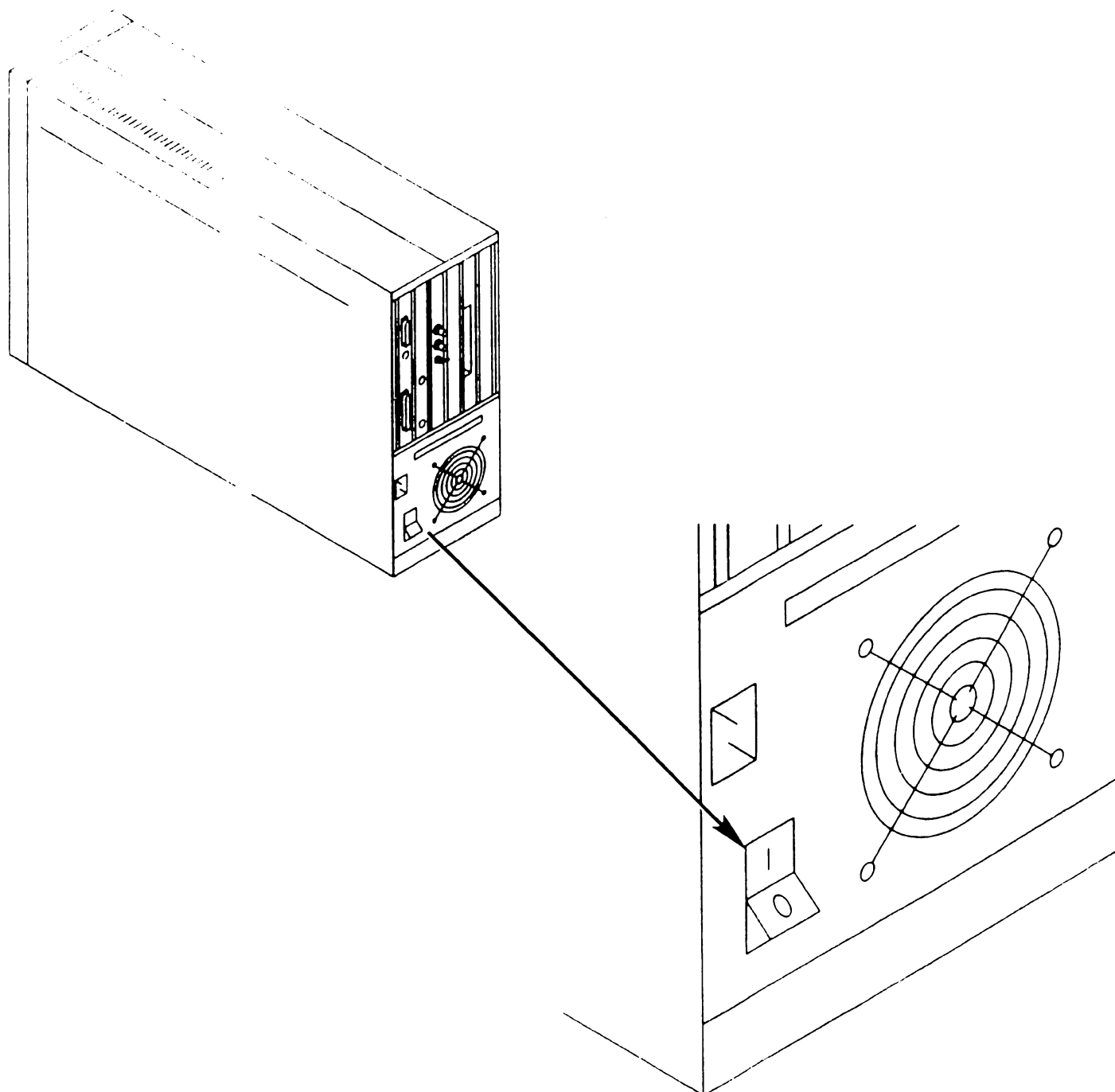

4.1 Power-on and B.I.T. Diagnostic Procedure (Sheet 4 of 14)

- 8) Press mainframe System Reset pushbutton.

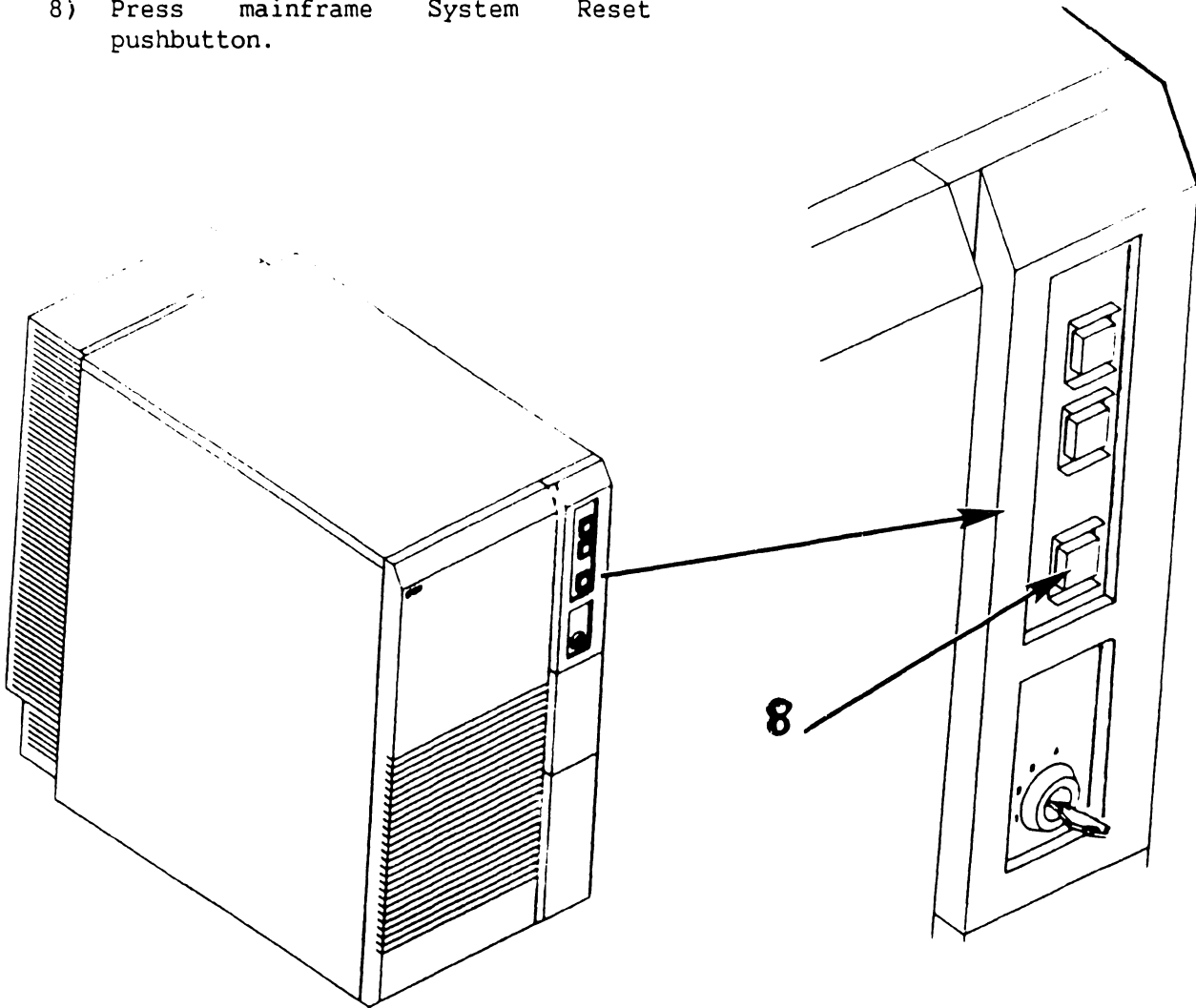

- 9) The SCU Start-Up screen is invoked and the following Start-Up message is displayed on the SCU screen.

WANG SUPPORT CONTROL UNIT REV. x.x.x
01 Start From Winchester

4.1 Power-on and B.I.T. Diagnostic Procedure (Sheet 5 of 14)

- 10) In a few seconds, the following is displayed on the SCU screen.

```
Wang Support Control Unit - BIOS x.x.x  
MS-DOS Version x.x.x
```

WANG

System Console

Copyright Wang Laboratories, Inc., 1987

4.1 Power-on and B.I.T. Diagnostic Procedure (Sheet 6 of 14)

11) The Console Processor Menu screen is then displayed.

NOTE

High-Lighted functions are functions allowed by the selected keyswitch position.

<<< System in Control Mode >>>

*** Wang VS System Console ***

SYSCON version x.x.x 11:03 AM Monday, October 5, 1987

Press (HELP) for online system console information.

Use the function keys to select a command.

- | | |
|---------------------------------|---------------------------|
| (1) ENTER Workstation Emulation | (8) Easy IPL And Dump |
| (2) ENTER CP Control | (9) Display Slot Contents |
| (5) AUTO IPL | (12) Set Console Defaults |
| (6) RSAF Functions | (13) Set Time and Date |

NOTE

System IPL can be accomplished in three ways: PF5 (AUTO IPL), PF8 (Easy IPL and Dump), and PF2 (Enter CP Control) (-9.7.2). The following IPL sequence is performed using selection PF5 (AUTO IPL).

4.1 Power-on and B.I.T. Diagnostic Procedure (Sheet 7 of 14)

12) Press PF5 (AUTO IPL). The following message is displayed

WARNING!! This function resets the system, RETURN to proceed or PF16 to abort''

13) Press 'RETURN'. The Workstation Initialization screen is displayed.

NOTE

If console defaults are incorrect or if CPU code has not been loaded, a CPU error or IPL Error will be displayed (-6.x.x). Select 'Set Console Defaults (PF12)' from the VS System Console Default screen to correct defaults and to load system microcode (-9.7.2).

Wang
VS
Workstation Emulation
Version x.xx

Initialization in Progress - Please Wait

4.1 Power-on and B.I.T. Diagnostic Procedure (Sheet 8 of 14)

14) Within a few seconds, the SYSGEN Configuration screen is displayed.

NOTE

If a configuration file has not been created, the system should be IPL'ed as one workstation and one disk (PF1 key) to allow system configuration file creation using GENEDIT (-9.7.3). Default values @CONFIG@ and @SYSTEM@ are used for configuration file and system library, respectively.

*** MESSAGE M001 BY SYSGEN

INFORMATION REQUIRED BY PROGRAM @SYSGEN@

Active Subprogram is @SYSGEN@

Copyright, Wang Laboratories, INC. 1985

Specify the name of the system configuration file and press (ENTER)

- or -

Press (1) to use one workstation and one disk.

SYSFILE = @CONFIG@

SYSLIB = @SYSTEM@

Specify the communications configuration file to be used, if any

COMFILE = ██████████

COMMLIB = @SYSTEM@

Inhibit logons at all workstations?

LOGONS = NO

Load Microcode to all Devices?

LMCODE = NO

Inhibit Dumping Continuable Halts?

CNDUMP = NO

4.1 Power-on and B.I.T. Diagnostic Procedure (Sheet 9 of 14)

15) The SYSGEN screen displays the name of the configuration file last used (SYSFILE Field). Enter a valid configuration file name in the field 'SYSFILE'. If the system is using communications, specify the communications configuration file name and library.

16) Respond to prompts as follows:

'Inhibit Logons at all workstations? Logons = NO□':
This prompt offers the option to inhibit logon operations for all workstations. If YES is answered, all workstations except SCU (PC) will be inhibited from logon operations. Default value is NO.

'Load Microcode to all Devices? LMCODE = NO□':
This prompt allows optional loading of microcode to all devices on the system with loadable microcode, including remote workstations. (Note that most devices load microcode when the device is first powered-on). If YES is selected, the system loads microcode to all microcode loadable devices, thus slowing down the IPL process significantly. Default value is NO.

'Inhibit Dumping Continuable Halts? CNDUMP = NO□':
This prompt enables or disables continuable dumps. If YES is selected, the system does not run continuable dumps, the error remains and system operation may be affected. Default value is NO.

4.1 Power-on and B.I.T. Diagnostic Procedure (Sheet 10 of 14)

17) Press 'RETURN'. The Initial Program Load (IPL) screen is displayed.

```

* * * * *
*
* WWWW      WWWW      AAA      NNN      NNN      GGGGGG      *
* WW        WW        AA AA    NNN      NN      GG      GG      *
* WW        WW        AA  AA    NN  N      NN      GG      GG      *
* WW  WW    WW        AA  AA    NN  N      NN      GG      GG      *
* WW  WW    WW        AAAAAAAAAA NN      N NN      GG      GGGG      *
* WW  WWWW  WW        AA  AA    NN      N NN      GG      GG      *
* WWWW  WWWW        AA  AA    NN      NNN      GG      GG      *
* WW    WW        AAAA  AAAA  NNN      NNN      GGGGGG      *
*
* * * * *
    
```

© Copyright Wang Laboratories, Inc. 1985

O.S. xx.xx.xx **System Generation In Progress** CP: xx.xx.xx

```

VVV      VVV      SSSSSS
VV       VV       SSS  SSS
VV       VV       SSS
VV       VV       SSSSS
VV       VV       SSSSS
VV  VV      SSS
VVV      SSS  SSS
VV       SSSSSS
    
```

18) The system checks critical operating system components for compatibility. If no problems are detected, the IPL continues. The message 'System Generation In Progress' is displayed in the center of the screen.

NOTE

If an incompatibility exists, the IPL sequence is stopped and a warning message is displayed by @SYSGEN@.

4.1 Power-on and B.I.T. Diagnostic Procedure (Sheet 11 of 14)

- 19) Once system generation has completed successfully, the following message is displayed.

I/O Subsystem Load in Progress

NOTE

The Date and Time screen will only appear if the SCU real time clock data is not useable or if N(o) is selected from the VS System Console Defaults menu (- 9.7.2).

- 20) In about one minute, the Time and Date screen is displayed.

*** MESSAGE WN3 BY IPL

INFORMATION REQUIRED BY PROGRAM @SYSGEN@

SET DATE AND TIME

YEAR = YY MONTH = MM DAY = DD
HOUR = HH MINUTE = MM SECOND = SS

Memory Size = 08192 K

- 21) Enter the date in the YY/MM/DD format. Enter the current time using the 24-hour clock format and press ENTER.
-

4.1 Power-on and B.I.T. Diagnostic Procedure (Sheet 12 of 14)

22) The following message is displayed:

System Initialization In Progress

23) When system initialization completes successfully, the Operator's Console screen is displayed.

*** Wang VS Operator's Console ***
10:12 AM Friday October 30, 1987

Position to (*) and Press (ENTER) to Provide Immediate Operator Service:

*MSG from QVR: Queue Verification Routine Complete 10:12

Press (1) to Return to User Mode

- or -

Use the Function Keys to Manage:

- | | |
|--------------------------|------------------------|
| 2) PRINT Queue | 9) PRINTERS |
| 3) PROCEDURE Queue | 10) DISKs |
| 4) TRANSMIT Queue | 11) TAPES |
| 5) RETRIEVE Queue | 12) TELECOMMUNICATIONs |
| | 13) WORKSTATIONs |
| 6) INTERACTIVE Tasks | |
| 7) NON-INTERACTIVE Tasks | 14) SYSTEM Options |

Press (HELP) at Any Time to Return to the Operator Console Menu

24) When the message 'Queue Verification Routine Complete' appears, acknowledge the message by positioning the cursor next to the message and press RETURN.

4.1 Power-on and B.I.T. Diagnostic Procedure (Sheet 13 of 14)

- 25) Press PF1 to enter user mode. The VS Logon screen is displayed.

```
*** Wang VS Logon ***  
Workstation 0          10:13 AM          Friday October 30, 1987  
  
Hello new user  
Welcome to Wang VS  
  
Please identify yourself by supplying the following information  
  
Your userid   = █  
Your password =  
  
and press (ENTER) to logon  
  
or press (PF1) to enter operator mode immediately
```

- 26) Enter the default three-letter user ID, CSG. No password is required. Press ENTER.

4.1 Power-on and B.I.T. Diagnostic Procedure (Sheet 14 of 14)

NOTE

Command Processor screen commands displayed are the commands enabled by the GENEDIT configuration file used to bring up the system (i.e. if WP is not enabled, PF(9) ENTER Word Processing will not be displayed).

27) The Command Processor screen is now displayed and the system is in user mode. This screen denotes the system has powered-up successfully.

*** WANG VS COMMAND PROCESSOR ***

Copyright, Wang Laboratories, INC. 1985

Workstation 0 Ready

10:15 AM

Friday October 30, 1987

Hello

Welcome to the Wang VS

Press (HELP) at any time to interrupt your program or to stop processing of current command.

Use function keys to select a command:

- | | |
|------------------------------------|-------------------------------|
| (1) RUN Program or Procedure | |
| (2) Set USAGE Constraints | (11) Enter OPERATOR Mode |
| (3) Show PROGRAM Completion Report | (12) Submit PROCEDURE |
| (4) Manage QUEUES | (13) Send MESSAGE to Operator |
| (5) Manage FILES/Libraries | (15) PRINT Command Screen |
| (6) Manage DEVICES | (16) LOGOFF |

4.2 Power-down Procedure (Sheet 1 of 5)

CAUTION

Powering down of system and/or any external disk or tape drive improperly may result in damage to Volume Table Of Contents (VTOC).

- 1) From Operators Console menu, press PF13 to verify all users have logged off system.
- 2) From Operators Console menu, press PF7 (Non-interactive Tasks) to check background tasks on system. Identify any user running a background task and advise user to suspend or terminate.
- 3) From Operators Console menu, press PF9 (Printers) and idle all printers.
- 4) Log off from the SCU.
- 5) Exit workstation emulation by pressing keyboard keys 'CONTROL', then 'SHIFT' and 'CANCEL' simultaneously. The Workstation Emulation menu is displayed.

Wang Professional Computer
DISK OPERATING SYSTEM
VS
Workstation Emulation
Version x.xx

Select an Item and Proceed

- Return to Emulation
- Suspend Emulation
- Terminate Emulation
- Restart Emulation

SPACE - Item Select
EXEC - Proceed

4.2 Power-down Procedure (Sheet 2 of 5)

- 6) Select 'Terminate Emulation' and press EXECUTE. The Console Processor screen is displayed.

```
<<< System in Control Mode >>>
```

```
*** Wang VS System Console ***
```

```
SYSCON version x.x.x      11:03 AM      Monday, October 5, 1987
```

```
Press (HELP) for online system console information.
```

```
Use the function keys to select a command.
```

- | | |
|---------------------------------|---------------------------|
| (1) ENTER Workstation Emulation | (8) Easy IPL and Dump |
| (2) ENTER CP Control | (9) Display Slot Contents |
| (5) AUTO IPL | (12) Set Console Defaults |
| (6) RSAF Functions | (13) Set Time and Date |
- 7) Press PF2, Enter CP Control. The VS Central Processor Control screen is displayed.

```
VS Central Processor Control
```

```
Select a PF Key to perform the indicated function
```

CPID	Current Status
0	Running

- | | |
|------------------------|-------------------|
| (1) CP(0) Control Mode | (8) Reset System |
| | (10) Load CP Code |
| | (16) Exit |

4.2 Power-down Procedure (Sheet 3 of 5)

- 8) Press PF8 (Reset System). Then press PF1 (CP (0) Control Mode). The VS Central Processor Control screen current status field changes as follows:

VS Central Processor Control

Select a PF Key to perform the indicated function

CPID	Current Status
0	Control Mode (IPL Requested)

(1) CP(0) Control Mode

(8) Reset System
(10) Load CP Code

(16) Exit

- 9) The mainframe is now in Control Mode. Power down all workstations.
- 10) 'Unready' external disk drives. Allow drive heads to return to home position.
- 11) Unload tape drives (if any).

4.2 Power-down Procedure (Sheet 4 of 5)

- 12) Power-down SCU by positioning the ac On/Off switch to the Off position.
- 13) Power-down mainframe by pressing power Off (red) pushbutton.

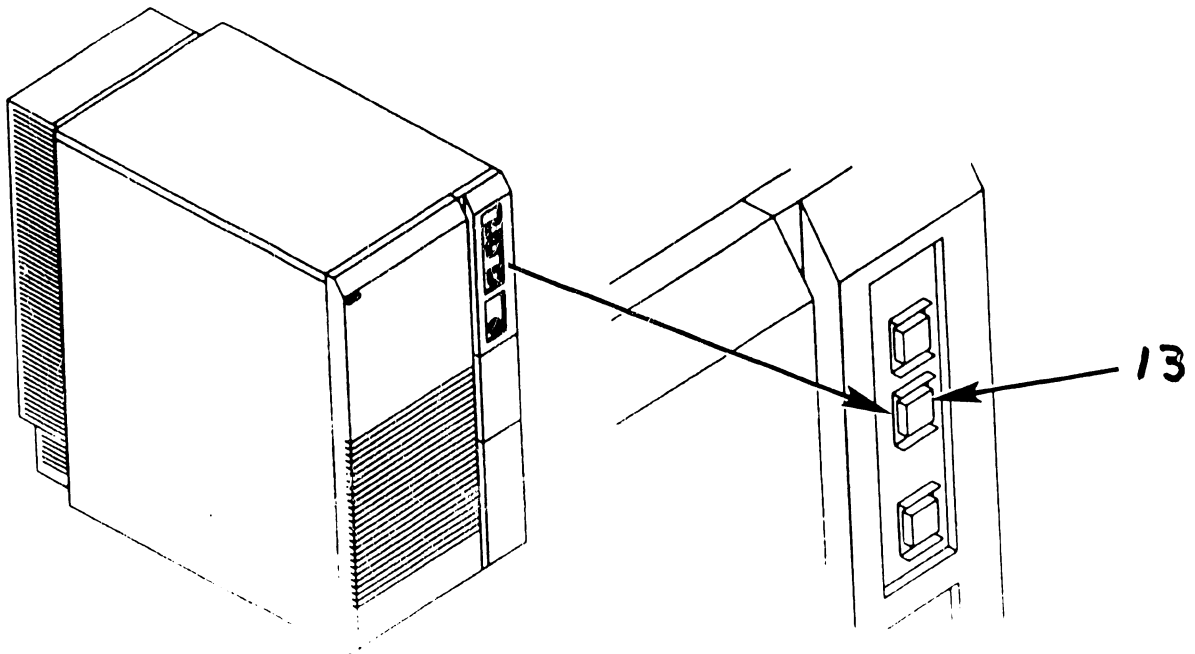
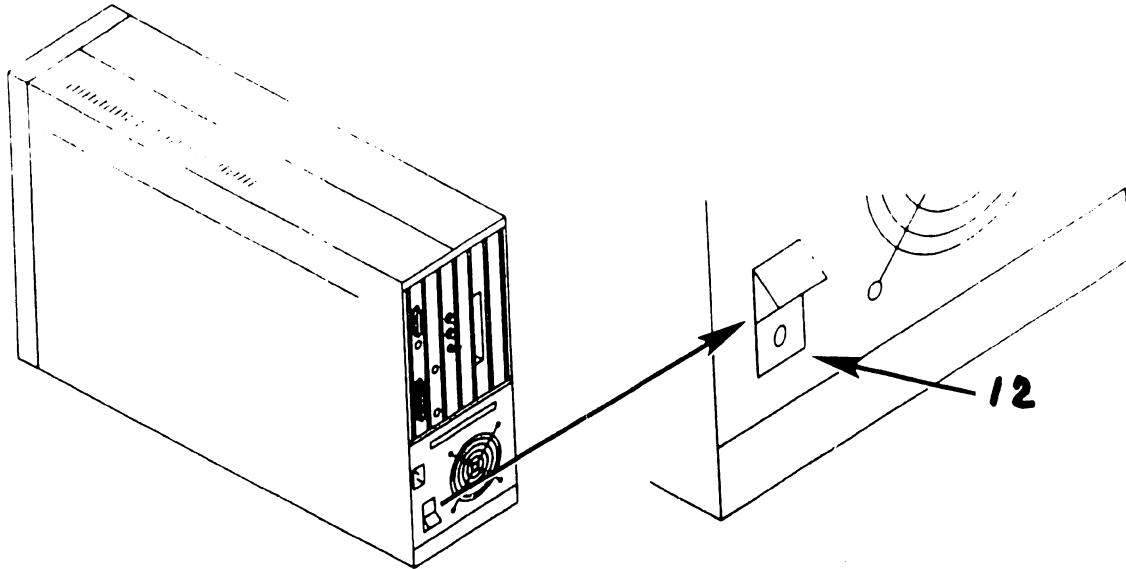

4.2 Power-down Procedure (Sheet 5 of 5)

- 14) Position mainframe ac On/Off circuit breaker to the Off position.
- 15) Remove mainframe ac power cord from ac power receptacle.

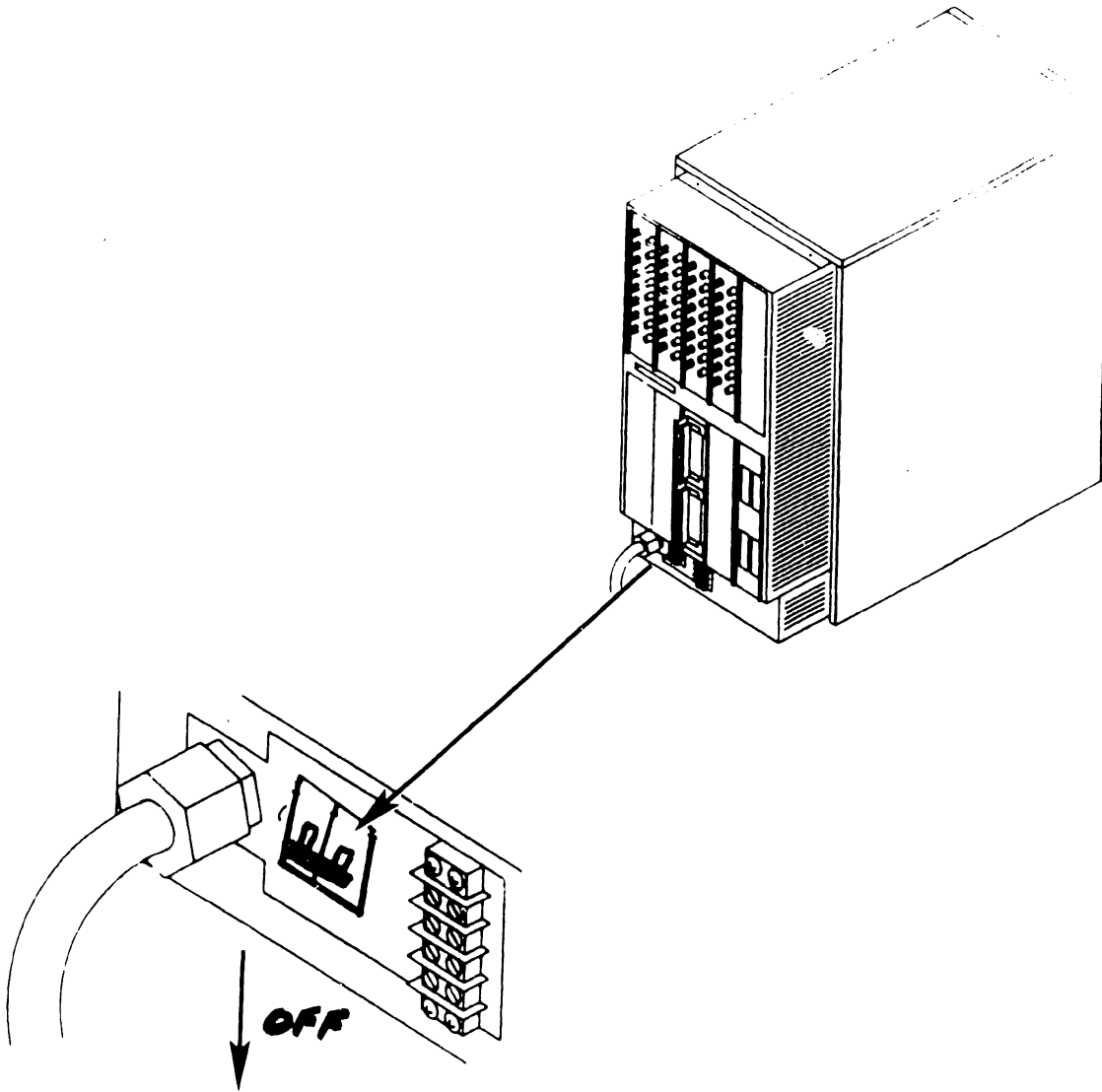

SECTION

5

**PREVENTIVE
MAINTENANCE**

SECTION 5
PREVENTIVE MAINTENANCE

	<u>Page</u>
5.1 MATERIALS REQUIRED	5-1
5.2 PM SCHEDULES	5-2
5.3 OPERATIONAL CHECK	5-3
5.4 CLEANING	5-4
5.5 INSPECTION	5-5
5.6 ADJUSTMENTS	5-6

5.1 Materials Required

The CE tool kit is required for preventive maintenance (PM) on the VS-7010 Computer System.

5.2 PM Schedules

The VS-7010 Computer System does not require any preventive maintenance. However, the service technician should perform the following while at the site during service calls.

Action	Section
Operational Check (IPL)	5.3
Clean Exterior	5.4
Clean Interior	5.4
Inspect	5.5
Adjust	5.6
Diagnostic Check	6.2

5.3 Operational Check

An equipment operational check is recommended after every service call. This test consists of running power-up diagnostics and checking the SCU display screen for possible error codes. This test is activated when the system is initially powered-up or when the control panel System Reset pushbutton is pressed.

Additional diagnostics tests may be performed; Off-Line diagnostics (→ 6.3.1) and On-Line diagnostics (→ 6.3.2) if required.

5.4 Cleaning

Exterior:

- 1) Remove foam air filter (→7.2.36) and clean.
- 2) Remove dust from exterior with cloth and vacuum.
- 3) Wipe case clean with soft cloth.

Interior:

- 1) Power-down system (→ 4.2) and remove top cover, front panel, side covers, and card cage cover (→7.2.1, 7.2.2, 7.2.3, 7.2.4) and vacuum interior.
- 2) Clean fan blades with cloth.

5.5 Inspection

- 1) Check for loose or damaged parts.
- 2) Check PCA and cable circuitry.
- 3) Check fan operation.

5.6 Adjustments

Mechanical:

- 1) None required.

Electrical:

- 1) Power Supply Adjustment:
(-8.2)

SECTION

6

TROUBLESHOOTING

SECTION 6 CONTENTS

SECTION 6 TROUBLESHOOTING

		<u>Page</u>
6.1	TOOLS AND EQUIPMENT	6-1
6.1.1	Special Tools	6-2
6.2	OFF-LINE DIAGNOSTICS	6-3
6.2.1	Power-Up Diagnostics	6-4
6.2.2	Accessing DCS Diagnostics	6-5
6.2.3	Running DCS Diagnostics	6-10

6.1 Tools and Equipment

Tools and equipment required to troubleshoot the VS-7010 Computer system consists of a standard CE tool kit and two types of diagnostic routines, Off-line diagnostics and On-line diagnostics.

6.1 Tools and Equipment

6.1.1 Special Tools and Equipment

Description	Part Number
RS232 Loopback Plug	421-0025
RS232/366 Loopback Plug	420-1041
RS449 Loopback Plug	270-3193
X.21 Loopback Plug	421-0010
20 dB Loopback Pad (2 each)	336-2002
Coax Cable (1 foot)	220-0314
Cable Simulator (optional)	190-0744
Power Supply Test Jumper	220-2342

6.2 Off-Line Diagnostics

NOTE

The customer cannot use the system while off-line diagnostics are running.

The VS-7010 off-line diagnostics are contained in an application program called Diagnostic Control System (DCS), which runs under MSDOS in the Support Control Unit (SCU). DCS is a collection of Central Processor (CP), Memory, and ICC diagnostics that resides on the Winchester fixed disk within the Professional Computer (PC) section of the SCU. DCS diagnostics may be run from the SCU, which consists of the PC and the SCU interface board, even when the VS system is not functioning.

6.2 Off-Line Diagnostics

6.2.1 Power-Up Diagnostics

At power-up (or control panel System Reset), DCS automatically invokes the Confidence Diagnostics. The Confidence Diagnostics determines whether the system will IPL and run. Confidence diagnostics consists of CPU Unit Diagnostics and I/O Built-In Test (BIT) monitor.

CPU Unit Diagnostic contain a partial test of the central processor, targeting primarily the interboard signals. I/O BIT Monitor tests all the IOCs installed in the system, including the board's controller and device adapter sections.

If an error occurs during the Confident Diagnostic, the diagnostic halts and an error message is displayed on the SCU console. This message includes the error code, and the most likely failing Field-Replacable Unit (FRU).

6.2 Off-Line Diagnostics

6.2.2 Accessing DCS Diagnostics (Sheet 1 of 6)

DCS diagnostics are accessed from the Wang VS System Console menu. This screen appears at power-up after the SCU software is loaded and can be reached by suspending workstation emulation from the SCU.

NOTE

To access off-line diagnostics, the control panel keyswitch must be in 'Remote Service' position. Position of the control panel keyswitch determines which of the menu items are available. Available items will be highlighted.

*** Wang VS System Console ***

SYSCON Version x.x.x

2:42 PM

Monday October 19, 1987

Press (HELP) for online system console information.

Use the function keys to select a command:

(1) ENTER Workstation Emulation
(2) ENTER Control Mode

(8) IPL System
(9) RESET Console

(5) AUTO IPL
(6) RSAF Functions

(12) SET Console Defaults
(13) SET Time and Date

6.2 Off-Line Diagnostics

6.2.2 Accessing DCS Diagnostics (Sheet 2 of 6)

Perform the following to access DCS diagnostics from the VS Operator's Console, VS Command Processor menu, or VS Logon screen.

- 1) Press 'CONTROL', then 'SHIFT' + 'CANCEL' simultaneously. The Workstation Emulation Menu screen is displayed.

Wang Professional Computer
DISK OPERATING SYSTEM
VS
Workstation Emulation
Version x.xx

Select an Item and Proceed

- Return to Emulation
- Suspend Emulation
- Terminate Emulation
- Restart Emulation

SPACE - Item Select
EXEC - Proceed

2. Space down to "Suspend Emulation" and press 'EXECUTE'. The Wang VS System Console Menu screen appears.

6.2 Off-Line Diagnostics

6.2.2 Accessing DCS Diagnostics (Sheet 3 of 6)

Certain elements of the System Console Menu are password-protected to prevent unauthorized use of some SYSCON facilities. These elements are not immediately displayed. They include (3) ENTER Service Log Mode and (4) ENTER Off-line Diagnostics. To enable these and other menu picks, perform the following:

NOTE

The control panel keyswitch must be in 'Remote Service' position.

From System Console Menu screen, enter the password:

CSG + current time (four digits as displayed on the System Console screen). (Example: If time is 9:30 (am or pm), enter 0930.)

NOTE

While entering the password, the keyboard beeper will sound as each key is pressed. This is normal and intended to discourage unauthorized personnel from enabling the full System Console menu.

The System Console is now in the 'service mode' and the full System Console menu is displayed.

6.2 Off-Line Diagnostics

6.2.2 Accessing DCS Diagnostics (Sheet 4 of 6)

NOTE

Service mode can be terminated by pressing PF10 or by positioning the keyswitch to another position (i.e. Normal Control).

*** Wang VS System Console ***

SYSCON Version x.x.x

2:44 PM

Monday October 19, 1987

Press (HELP) for online system console information.

Use the function keys to select a command:

- | | |
|---------------------------------|-----------------------------|
| (1) ENTER Workstation Emulation | (8) IPL System |
| (2) ENTER Control Mode | (9) RESET Console |
| (3) ENTER Service Log Mode | (10) Terminate Service Mode |
| (4) ENTER Offline Diagnostics | (11) SHOW Error Log |
| (5) AUTO IPL | (12) SET Console Defaults |
| (6) RSAF Functions | (13) SET Time and Date |
| (29) Install Software | (32) Wang PC Emulation |

Press PF4 (Enter Offline Diagnostics) from the System Console Menu. The Diagnostics Disclaimer screen appears.

6.2 Off-Line Diagnostics**6.2.2 Accessing DCS Diagnostics (Sheet 5 of 6)**

Wang VS Diagnostic Control System
Rev xxxx (c) Copr. Wang Laboratories, Inc. 1986

-----N O T I C E-----

This diagnostic package is the property of Wang Laboratories, Inc. and is provided for System diagnostic use only. Improper use may cause loss or damage to programs and/or data. This package and related materials may not be disclosed or otherwise made available to third parties without the prior permission of Wang.

In no event shall Wang Laboratories, Inc. or its subsidiaries be liable for incidental or consequential damages in connection with or arising from the use of the diagnostic package, the accompanying manual, or any related materials.

Press EXEC to continue, CANCEL to exit

From the Diagnostics Disclaimer screen, press 'EXEC' to display the DCS Diagnostic Selection Menu.

6.2 Off-Line Diagnostics**6.2.2 Accessing DCS Diagnostics (Sheet 6 of 6)**

Wang VS Diagnostic Control System hh/mm
Rev xxxx (c) Copr. Wang Laboratories, Inc. 1986

01 PCI Test

- _ SCUI Test
- _ CP8 Static Test
- _ CP8 Self Test
- _ AGU, ESU Test
- _ ATU Test
- _ SCU / Memory Test
- _ CPU / Memory Test
- _ SBI Test
- _ I/O BIT Monitor
- _ CPU Unit Test
- _ FPU Test

- _ SuperBal
- _ VS Environment

SPACE - item position
INSERT - select
DELETE - deselect
SHIFT+INSERT - hex #
EXEC - proceed

HELP is available

NOTES

It is possible that DCS may not find the SuperBal test file on disk. Before running offline diagnostics, it will be necessary to change the source of the CPU Microcode File (-9.9).

The AGU diagnostics require DCS Rev 2695 or higher.

FPU diagnostics are not supported on the VS-7010.

6.2 Off-Line Diagnostics

6.2.3 Running DCS Diagnostics

Choose a particular diagnostic from the DCS Menu by position the cursor next to the desired diagnostic using the SPACEBAR. Press 'INSERT' to select the diagnostic.

NOTES

SHIFT+INSERT allows selection of elements to be tested when multiple elements, such as dual CPUs, are in the system. This feature is for the VS-7300 series. The default selection for SHIFT+INSERT is 01. Use the default selection for VS-7010 mainframe.

For best results, run the diagnostics in the order in which they are listed on the menu.

Press 'EXEC' to run the diagnostic. More than one diagnostic or all diagnostics may be selected at one time.

To deselect a single diagnostic, go to the DCS Menu, position the cursor next to the diagnostic to be deselected, and press DELETE. The diagnostic will be dehighlighted on the DCS Menu and will not execute until it is reselected. To deselect all selected diagnostics, press CANCEL. To terminate a diagnostic, press SHIFT + CANCEL. SHIFT + CANCEL is also used to exit the DCS program from the selection menu.

6.2 Off-Line Diagnostics

6.2.3.1 HELP Menu

DCS HELP Menu is an operator aid that allows the user to display the DCS help text file, display the currently executing diagnostic's help text file, display the DCS log file, and employ the VS Interface Utility. HELP is accessed by pressing the HELP key or SHIFT + HELP keys at any time. Function keys have no effect during the help feature but, their state can be changed.

Wang VS Diagnostic Control System hh/mm
Rev XXXX (c) Copr. Wang Laboratories, Inc. 1986

H E L P M E N U

- Display DCS help file
- Display current diagnostic's help file
- Display log
- VS Interface Utility

SPACE - item select
EXEC - proceed
CANCEL - exit menu

DCS rev XXXX

6.2 Off-Line Diagnostics

6.2.3.2 DCS Test Screens (Sheet 1 of #)

Once a diagnostic is selected and EXEC is pressed, a screen specific to that diagnostic is displayed. These screens provide information including: sequence number, diagnostic revision number and name, the error count, the currently executing diagnostic or test, and the DCS status.

Most of the DCS diagnostic screens are similar with the exception of the VS Environment Diagnostic and the I/O BIT Monitor. Some diagnostics contain menus of their own which allow the user to select or deselect one or more tests within the diagnostic. Tests on these menus are selected and deselected the same way that diagnostics are selected and deselected from the DCS Selection menu. A possible diagnostic screen is illustrated as follows:

```
                Wang VS Diagnostic Control System                hh/mm
Rev XXXX      (c) Copr. Wang Laboratories, Inc. 1986
                □□□□ ■□□□ □□□□ □□□□

Sequence: 1                                Error Cnt: 1
Diagnostic: R1560 CP8 Diagnostics
Test: Part Two
Error Code: 201033
Failing Unit: (1) ATU0 (2) AGU0 (3) CPU0
```

```
| DCS Status: Reporting Diagnostic Error |
```

Error detected by diagnostic

CPU halted at MIA = 07D3

Press PF6 key to continue from error

HELP is available

6.2 Off-Line Diagnostics

6.2.3.2 DCS Test Screens (Sheet 2 of #)

The row of boxes indicates which optional functions (if any) are enabled. The boxes correspond to function keys 1 thru 16. Each function key acts as an on/off switch to enable or disable the particular action that the key controls. A filled box indicates the function is enabled; an empty box indicates the function is disabled. Table 6-1 below lists the controlling function keys, the function name, and a description of each function.

Table 6-1. Special Diagnostic Functions

PF KEY	Function	Description
2	Loop on Error	When an error is reported, the DCS will instruct the diagnostic to loop on the error. The DCS will also count and display the number of times the loop is executed.
3	Loop on Test	The DCS instructs the diagnostic to loop on the just completed test. The DCS counts and displays the number of times the loop is executed.
4	Loop on Diagnostic	The DCS instructs the diagnostic to loop on itself. The DCS counts and displays the number of times the loop is executed.
5	Stop on Error	When an error is reported, the DCS stops and waits for the user to press PF key 6 before continuing the diagnostic.
6	Step - from	This key is used to continue from a stop on error, to disable the current looping function without using the loop function key, and to continue from a pause state without turning off the pause function.

6.2 Off-Line Diagnostics

Table 6-1. Special Diagnostic Functions (Cont'd)

PF KEY	Function	Description
7	Log Screen	Enters current screen into the log.
8	Pause	The DCS will pause on requests (calls) from the diagnostic to the DCS before the requested function is performed. PF key 6 can be used to continue or the function can be disabled.
9	Not used	
10	Not used	
11	Not used	
12	Not used	
13	Not used	
14	Not used	
15	Not used	
16	Next Diagnostic	Abort the currently executing diagnostic and load and execute the next diagnostic in the sequence.

SECTION

7

REPAIR

SECTION 7

REPAIR

	<u>Page</u>
7.1	Tools And Test Equipment 7-1
7.2	Removal Procedures 7-2
7.2.1	Top Cover Removal 7-2
7.2.2	Front Cover Removal 7-3
7.2.3	Side Covers Removal 7-4
7.2.4	Card Cage Cover Removal 7-5
7.2.5	General PCB Removal 7-6
7.2.6	Central Processing Unit (CPU) Removal 7-8
7.2.7	Address Generation Unit (AGU) Removal..... 7-10
7.2.8	Address Translation Unit (ATU) Removal 7-12
7.2.9	Support Control Unit (SCU) Removal 7-14
7.2.10	Memory Control Unit (MCU) Removal 7-15
7.2.11	Main Memory (MEM) Board (210-8307/-1) Removal 7-17
7.2.12	Main Memory (MEM) Board (210-9874/-1) Removal 7-19
7.2.13	System Bus Interface (SBI) Removal 7-21
7.2.14	SMD Controller (23V98-4) IOC Removal 7-23
7.2.15	Serial Controller (23V67) IOC Removal 7-26
7.2.16	Kennedy Tape (23V95-1) IOC Removal 7-28
7.2.17	Telex Tape (23V95-2) IOC Removal 7-30
7.2.18	Multiline TC (23V86/96) IOC Removal 7-32
7.2.19	Power Supply Controller Removal 7-34
7.2.20	DC Power Distribution Unit (PDU) Removal 7-37

7.1 Tools And Test Equipment

No special tools or test equipment are required to repair the VS-7010 Computer system. All necessary repair can be accomplished using the Wang CE tool kit (WLI# 726-9401).

WARNING

THIS COMPUTER EQUIPMENT HAS BEEN VERIFIED AS FCC CLASS A.

IN ORDER TO MAINTAIN COMPLIANCE WITH FCC CLASS A VERIFICATION, THE FOLLOWING CONDITIONS MUST BE ADHERED TO DURING NORMAL OPERATION OF EQUIPMENT.

- ALL COVERS MUST BE ON THE SYSTEM AND SECURED IN THE PROPER MANNER.
 - ALL INTERNAL CABLES MUST BE ROUTED IN THE ORIGINAL MANNER WITHIN THE CABLE CLAMPS PROVIDED FOR THAT PURPOSE.
 - ALL EXTERNAL CABLES MUST BE SECURED AND THE PROPER CABLE USED TO ENSURE THAT CABLE SHIELDING IS PROPERLY GROUNDED TO THE CABLE CLAMPS PROVIDED.
 - ALL HARDWARE IS PROPERLY SECURED.
-

7.2 Removal Procedures

7.2.1 Top Cover Removal

- 1) Power off mainframe and disconnect ac power. (-4.2)
- 2) Remove two screws from rear of top cover.
- 3) Lift rear of top cover up two inches and slide top cover towards the rear of unit and remove.

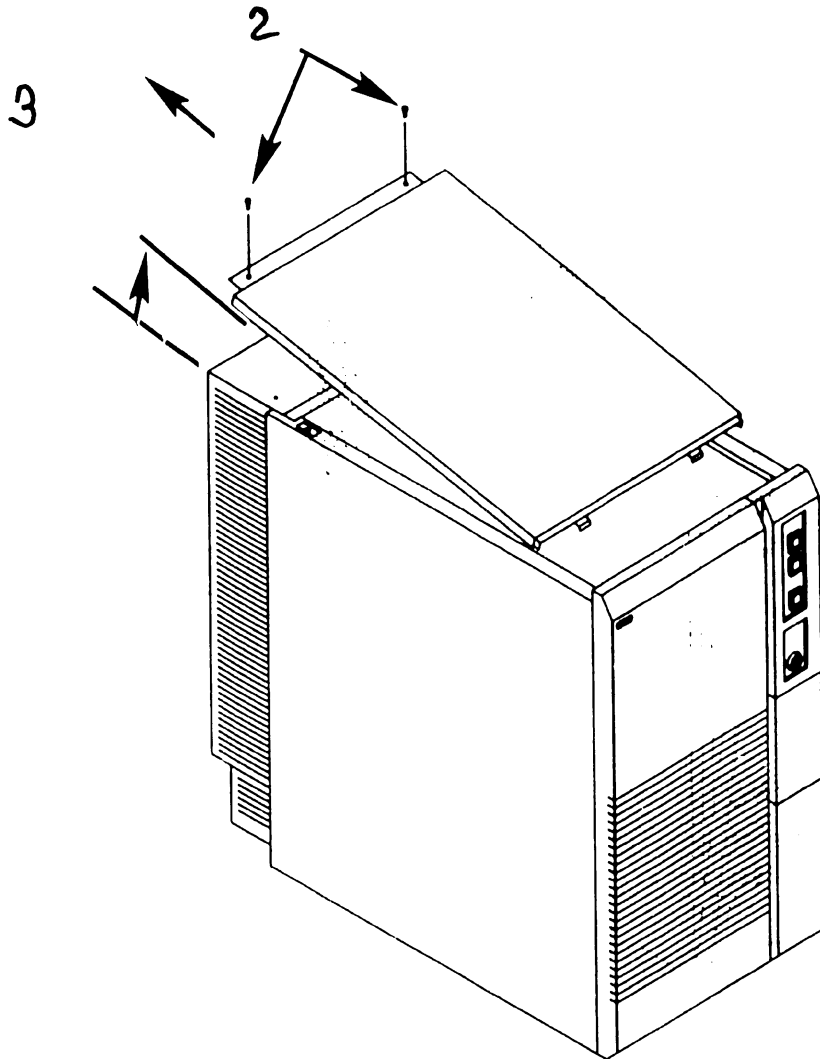

7.2 Removal Procedures

7.2.2 Front Cover Removal

- 1) Power off mainframe and disconnect ac power. (→4.2)
- 2) Remove top cover. (→7.2.1)
- 3) Loosen two screws securing front cover to chassis.
- 4) Tilt front cover forward enough to clear screws and lift cover off.

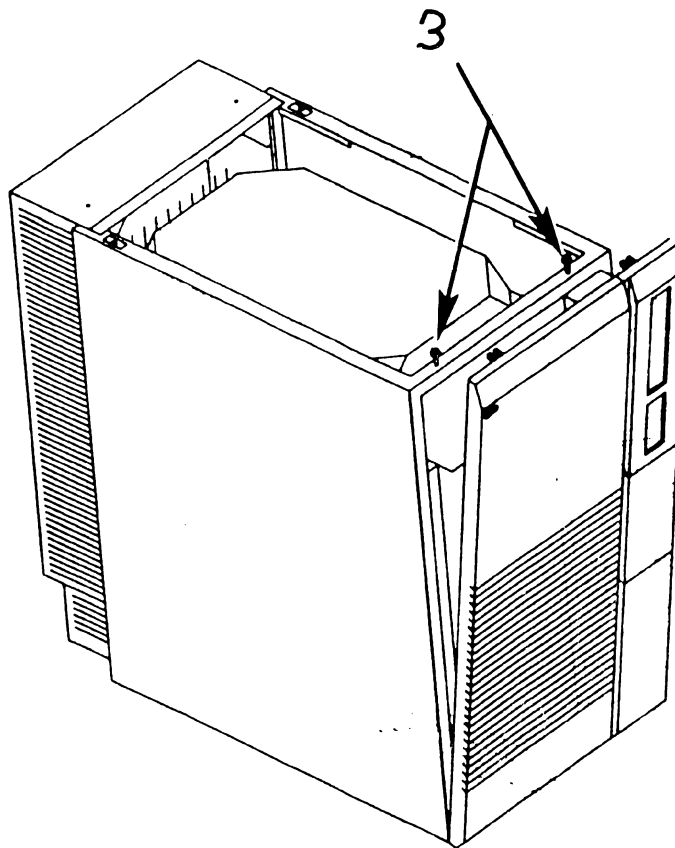

7.2 Removal Procedures

7.2.3 Side Cover Removal

- 1) Power off mainframe and disconnect ac power. (-4.2)
- 2) Remove top cover. (-7.2.1)
- 3) Remove front cover. (-7.2.2)
- 4) Lift side covers upward two inches to disengage cover tabs and remove.

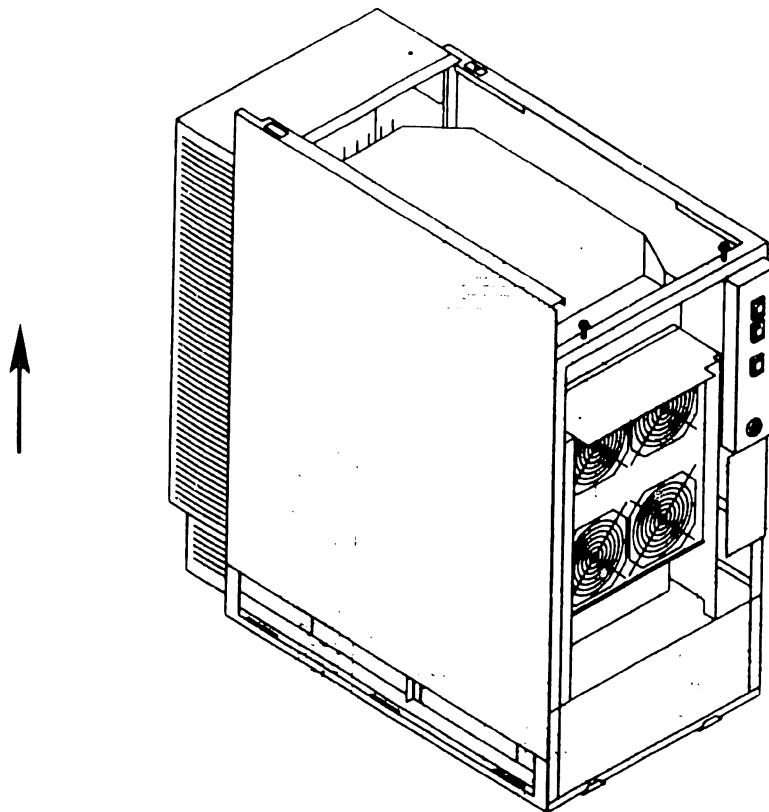

7.2 Removal Procedures

7.2.4 Card Cage Cover Removal

- 1) Power off mainframe and disconnect ac power. (-4.2)
- 2) Remove top cover. (-7.2.1)
- 3) Remove four screws securing card cage cover to card cage.
- 4) Remove card cage cover.

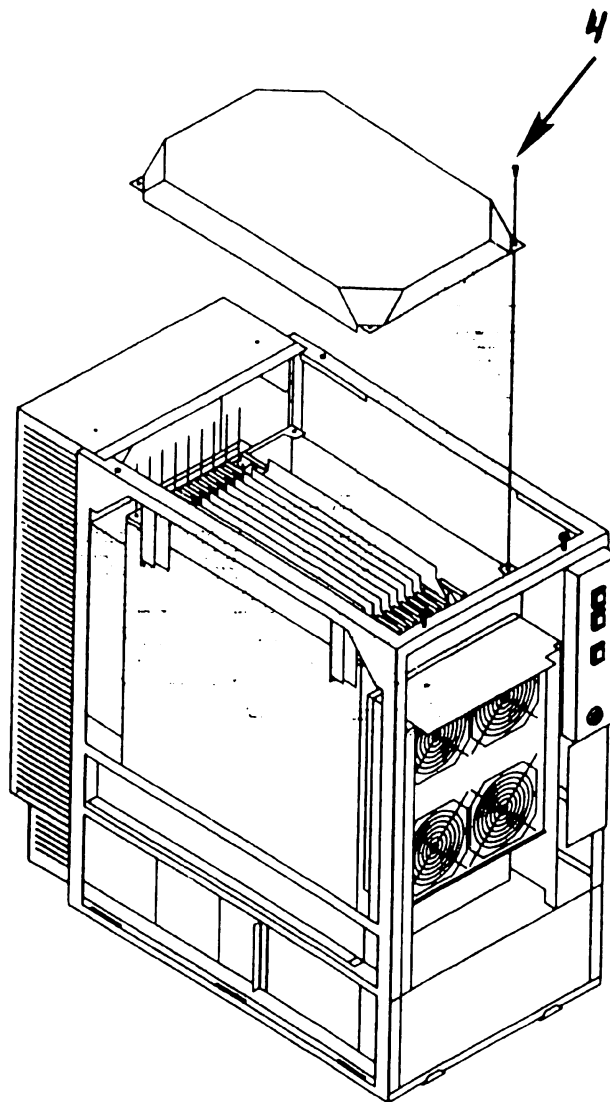

7.2 Removal Procedures

7.2.5 General PCB Removal (Sheet 1 of 2)

NOTE

General PCB removal procedures are procedures common to all PCBs within the card cage. Procedures specific to PCBs are found under the associated PCB heading. These procedures should be followed when removing PCBs from the card cage.

- 1) Power off mainframe and disconnect ac power. (~4.2)
- 2) Remove top cover. (~7.2.1)
- 3) Remove card cage cover (~7.2.4)
- 4) Note cable routing and location and remove cables from PCB connectors.
- 5) Note PCB location. A board locator label is mounted on the fan shroud assembly. PCBs must be installed in the correct backplane slot.

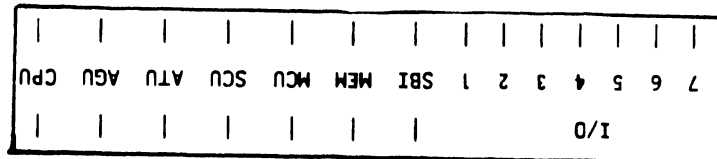

NOTE

Option PCBs SMD Controller IOC and Serial IOC are option slot dependant as follows:

- First SMD must be installed in I/O slot 1.
- First Serial IOC (supporting SCU) must be installed in I/O slot 3.

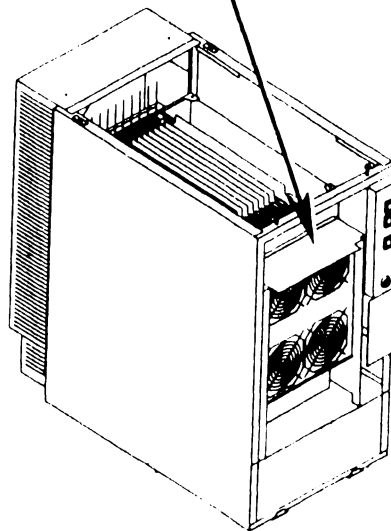

7.2 Removal Procedures

7.2.5 General PCB Removal (Sheet 2 of 2)

- 6) Position PCB lever clamps to open position by pulling clamp away from PCB, thus freeing PCB from card cage connectors.

CAUTION

Be careful when removing and handling the large flexible VS-7010 boards.

- 7) Pull PCB out of card cage by sliding on associated card cage guides.

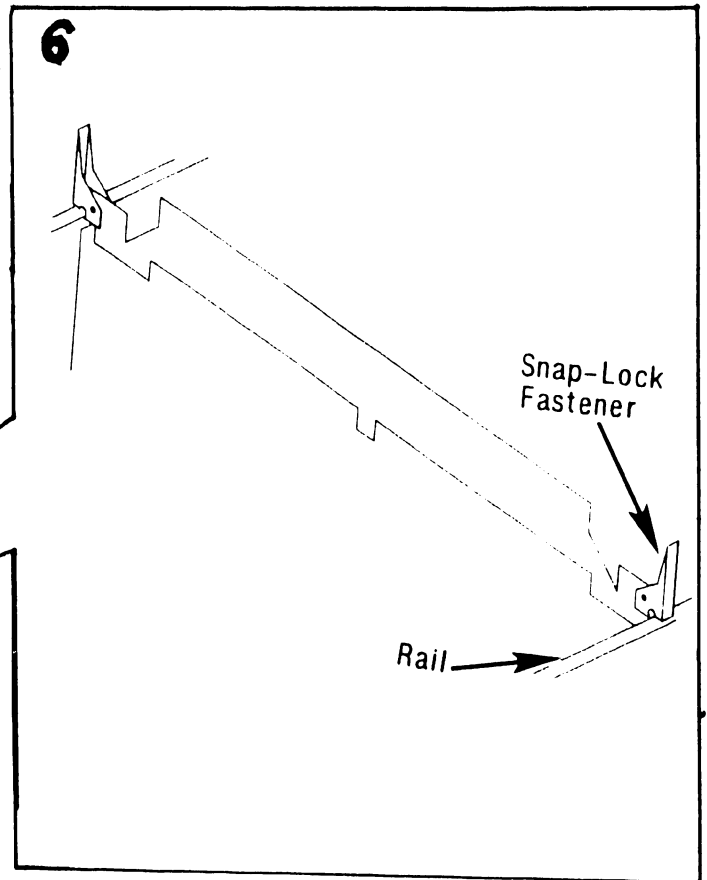
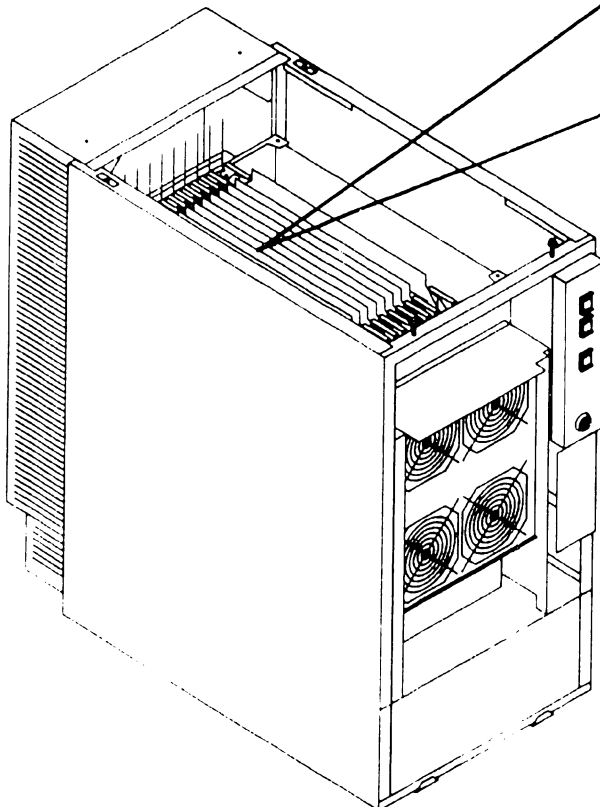

7.2 Removal Procedures

7.2.6 Central Processing Unit (CPU) Removal (Sheet 1 of 2)

- 1) Power off mainframe and disconnect ac power. (~4.2)
- 2) Remove top cover. (~7.2.1)
- 3) Remove card cage cover (~7.2.4)
- 4) Note cable position and remove 50-pin cable from connector J1 (CPU J1 to AGU J1).
- 5) Remove PCB from backplane. (~ 7.2.5)

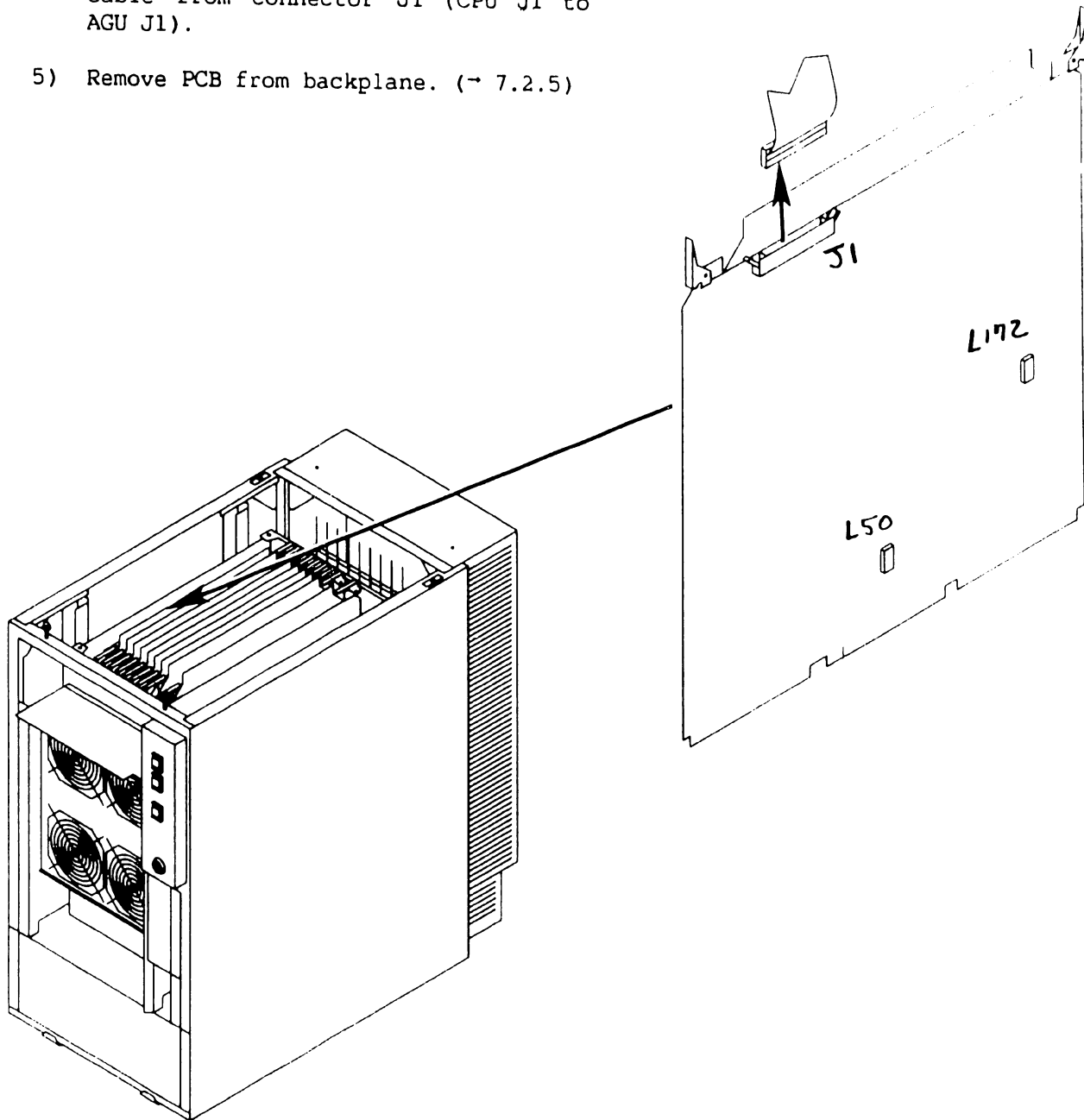

7.2 Removal Procedures

7.2.6 Central Processing Unit (CPU) Removal (Sheet 2 of 2)

- 6) Verify proper jumper positions of CPU Clock jumpers at location L50.
- 7) Verify proper jumper positions of Support Packet Bus (SPB) Target ID jumpers at location L172.

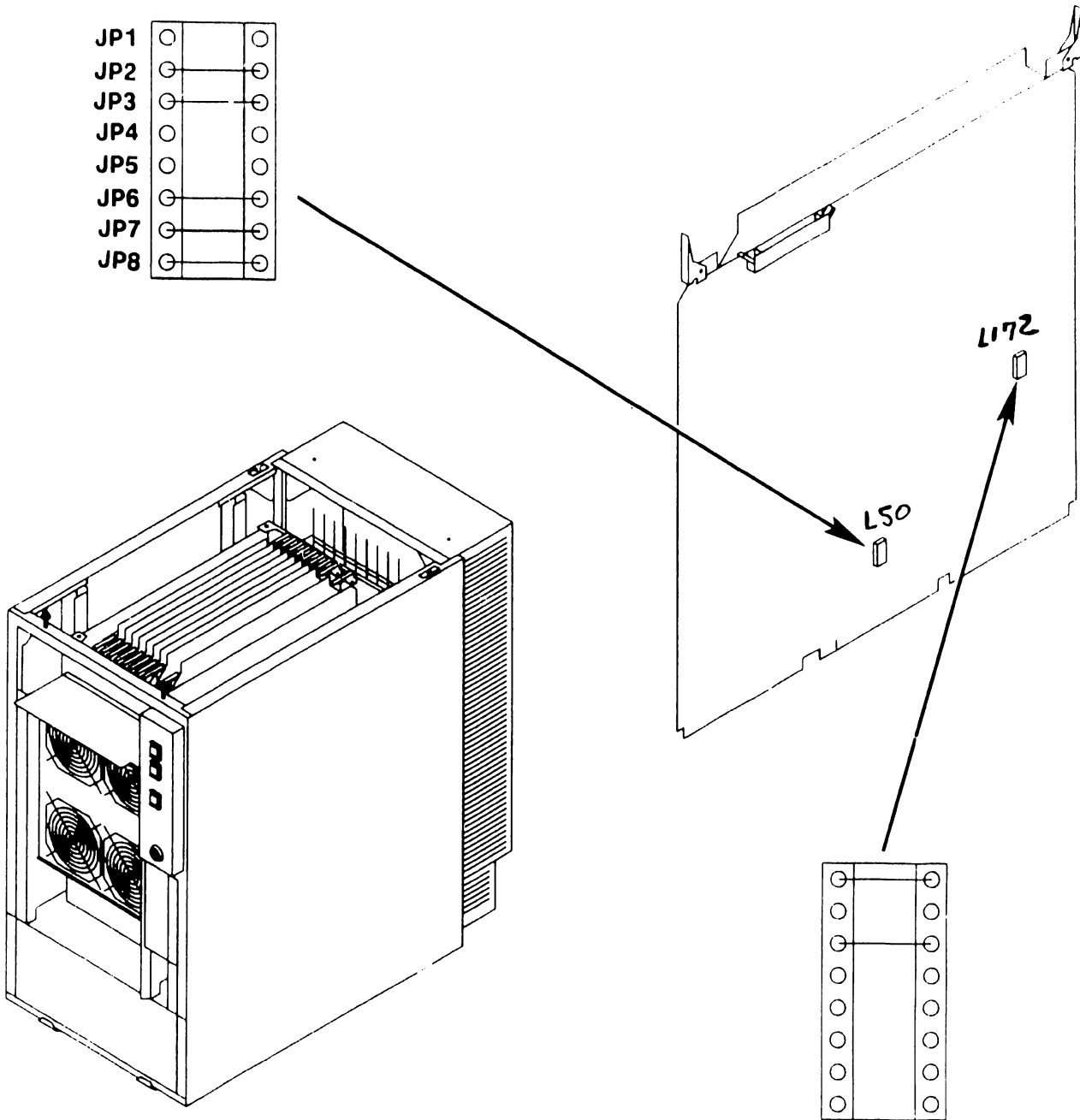

7.2 Removal Procedures

7.2.7 Address Generation Unit (AGU) Removal (Sheet 1 of 2)

- 1) Power off mainframe and disconnect ac power. (→4.2)
- 2) Remove top cover. (→7.2.1)
- 3) Remove card cage cover (→7.2.4)
- 4) Open cable clamp to the right. Note cable position and remove 50-pin cable from connector J1 (AGU J1 to CPU J1) and connector J2 (AGU J2 to ATU J1).
- 5) Remove PCB from backplane. (→ 7.2.5)

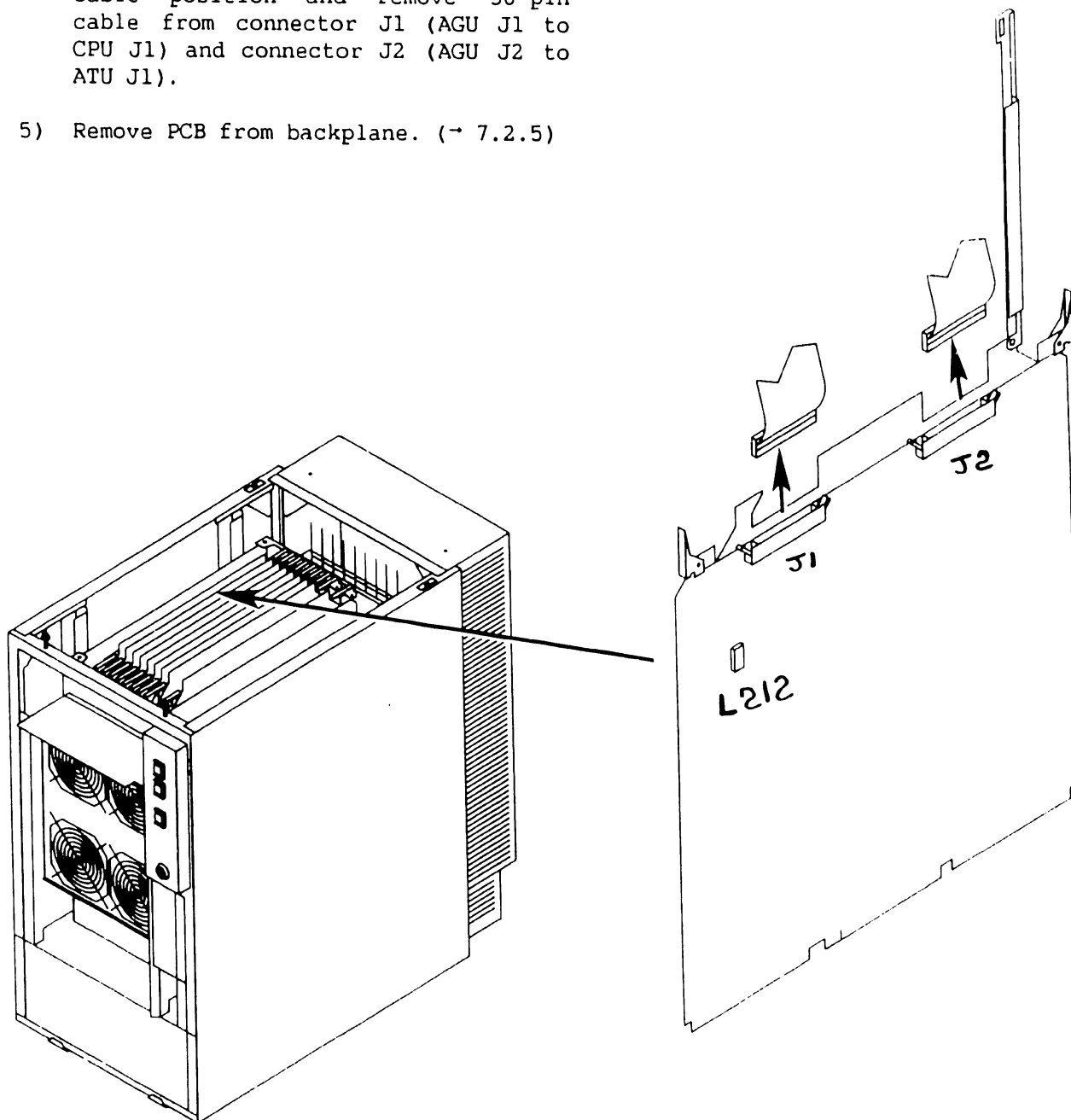

7.2 Removal Procedures

7.2.7 Address Generation Unit (AGU) Removal (Sheet 2 of 2)

- 6) Verify proper jumper positions of Oscillator jumpers at location L212.

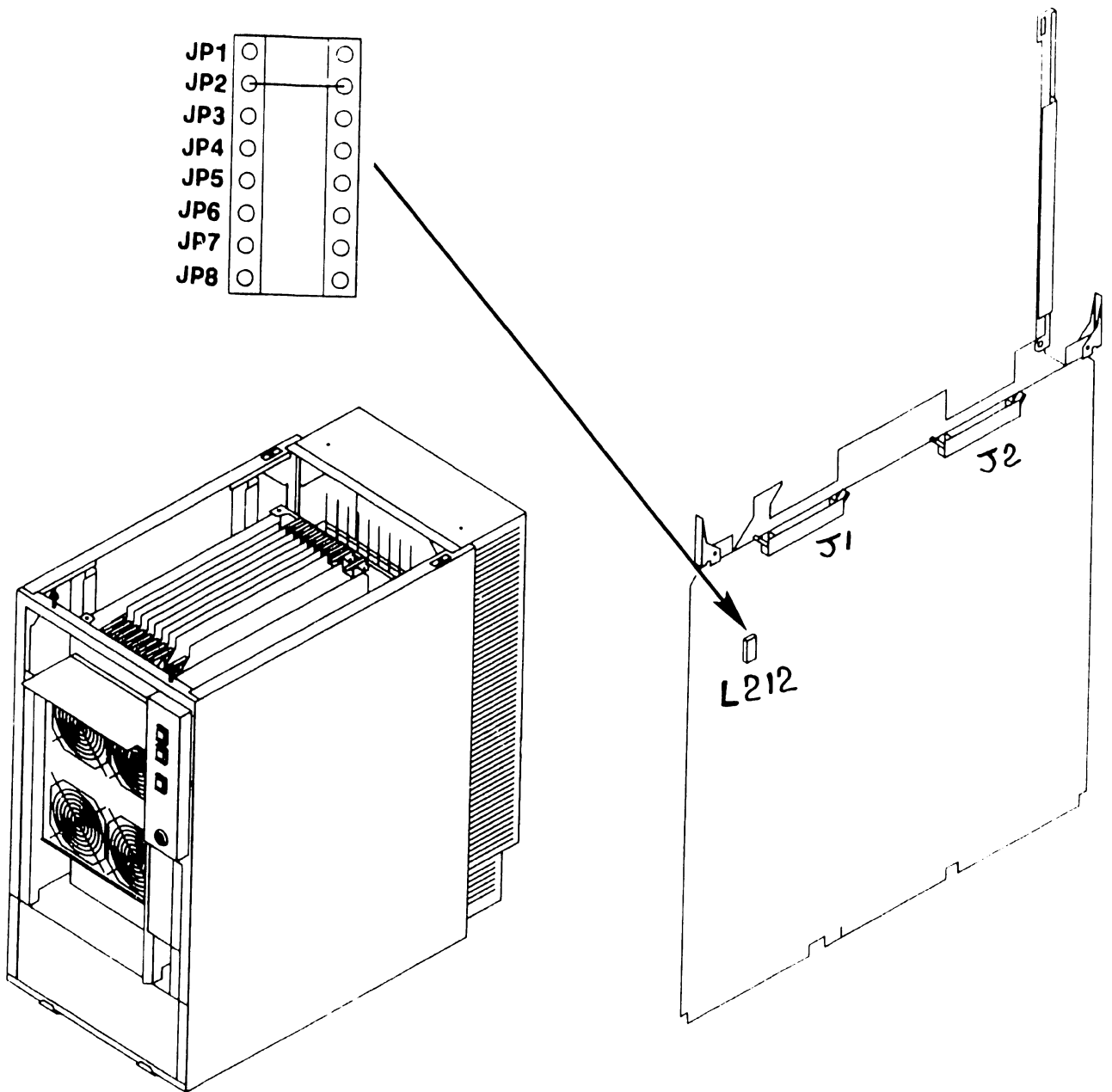

7.2 Removal Procedures

7.2.8 Address Translation Unit (ATU) Removal (Sheet 1 of 2)

- 1) Power off mainframe and disconnect ac power. (-4.2)
- 2) Remove top cover. (-7.2.1)
- 3) Remove card cage cover (-7.2.4)
- 4) Open cable clamp to the right. Note cable position and remove 50-pin cable from connector J1 (ATU J1 to AGU J2).
- 5) Remove PCB from backplane. (- 7.2.5)

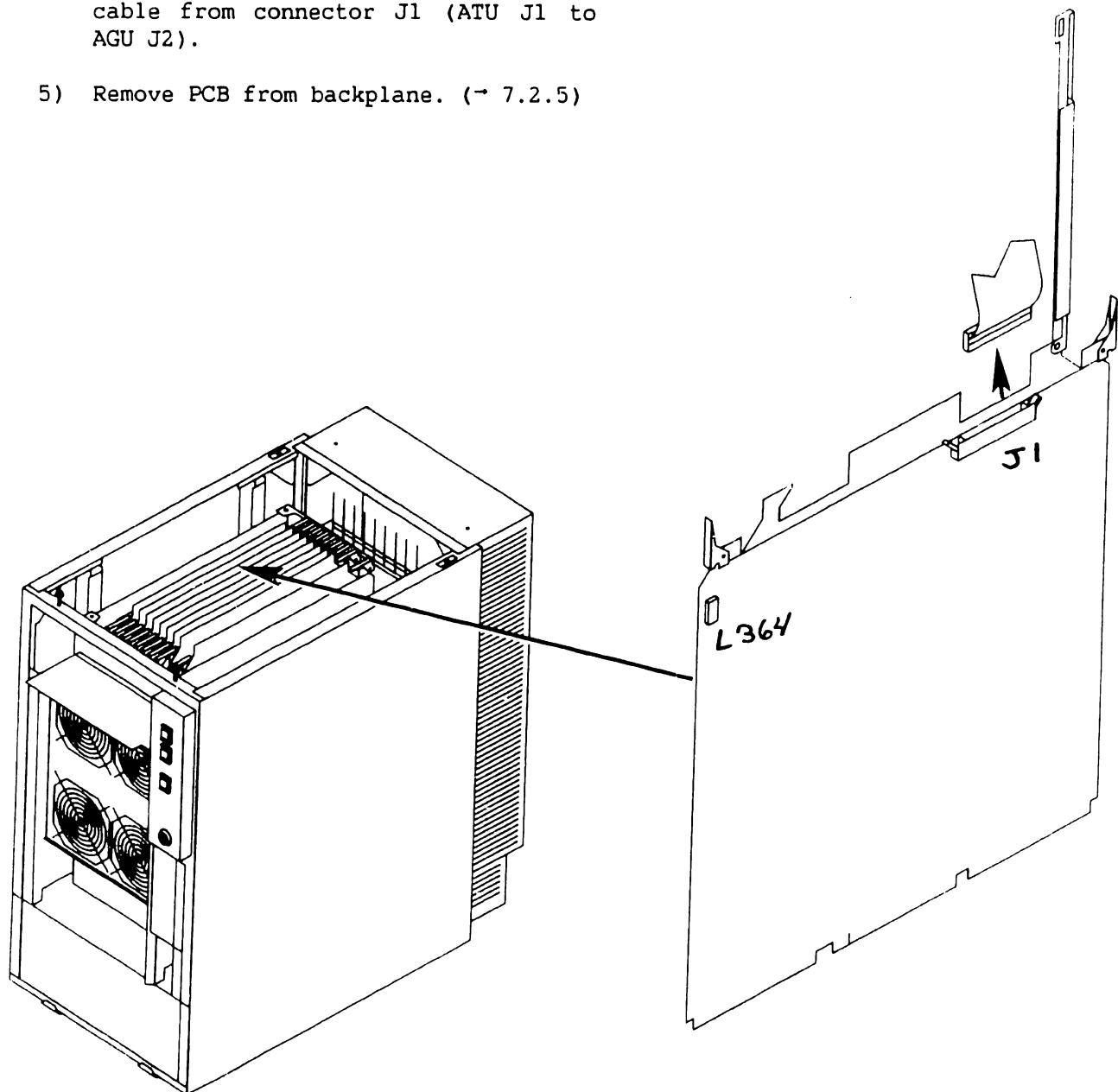

7.2 Removal Procedures

7.2.8 Address Generation Unit (AGU) Removal (Sheet 2 of 2)

- 6) Verify proper jumper positions of IPC Destination Processor jumpers at location L364.

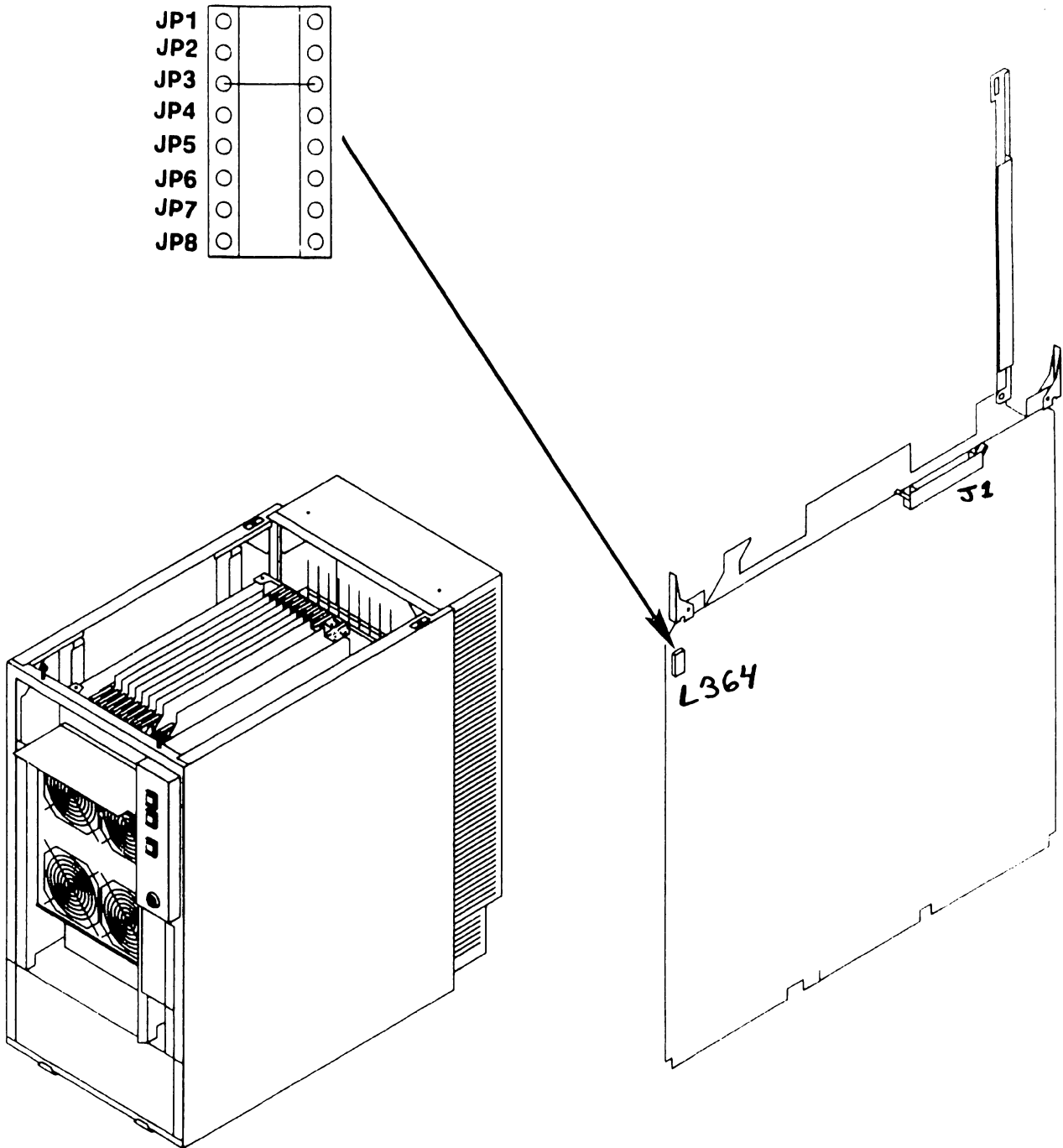

7.2 Removal Procedures

7.2.9 Support Control Unit (SCU) Removal

- 1) Power off mainframe and disconnect ac power. (~4.2)
 - 2) Remove top cover. (~7.2.1)
 - 3) Remove card cage cover (~7.2.4)
-

NOTE

The Support Control Unit does not contain any jumpers, switches or cables.

- 4) Remove PCB from backplane. (~ 7.2.5)

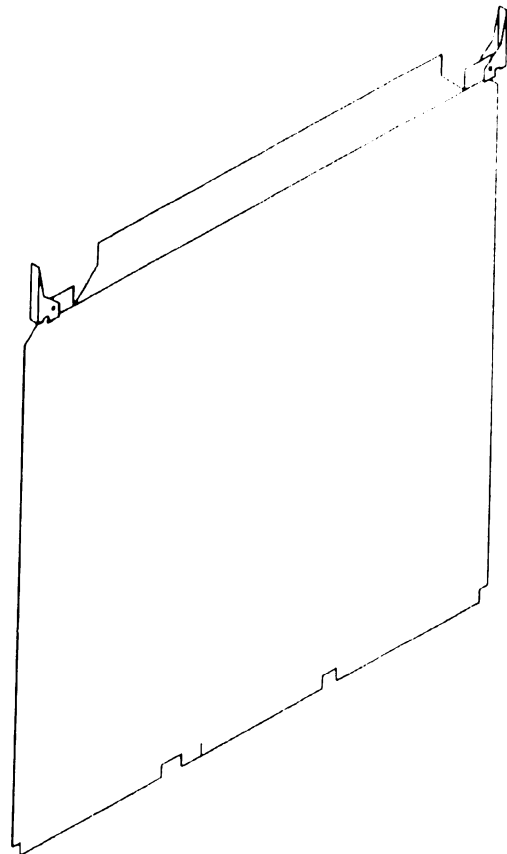
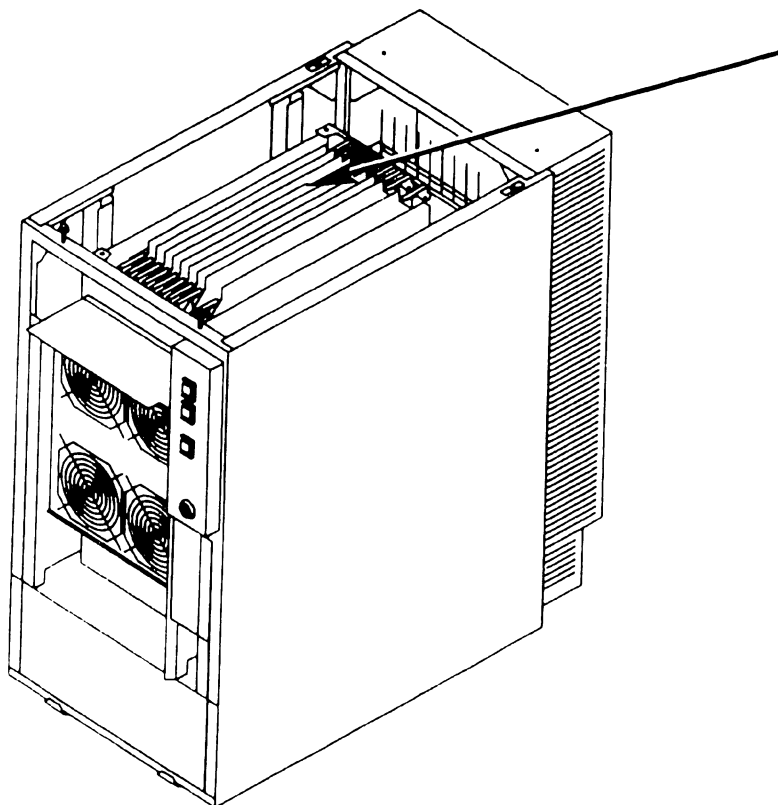

7.2 Removal Procedures

7.2.10 Memory Control Unit (MCU) Removal (Sheet 1 of 2)

- 1) Power off mainframe and disconnect ac power. (-4.2)
- 2) Remove top cover. (-7.2.1)
- 3) Remove card cage cover (-7.2.4)
- 4) Remove PCB from backplane. (- 7.2.5)

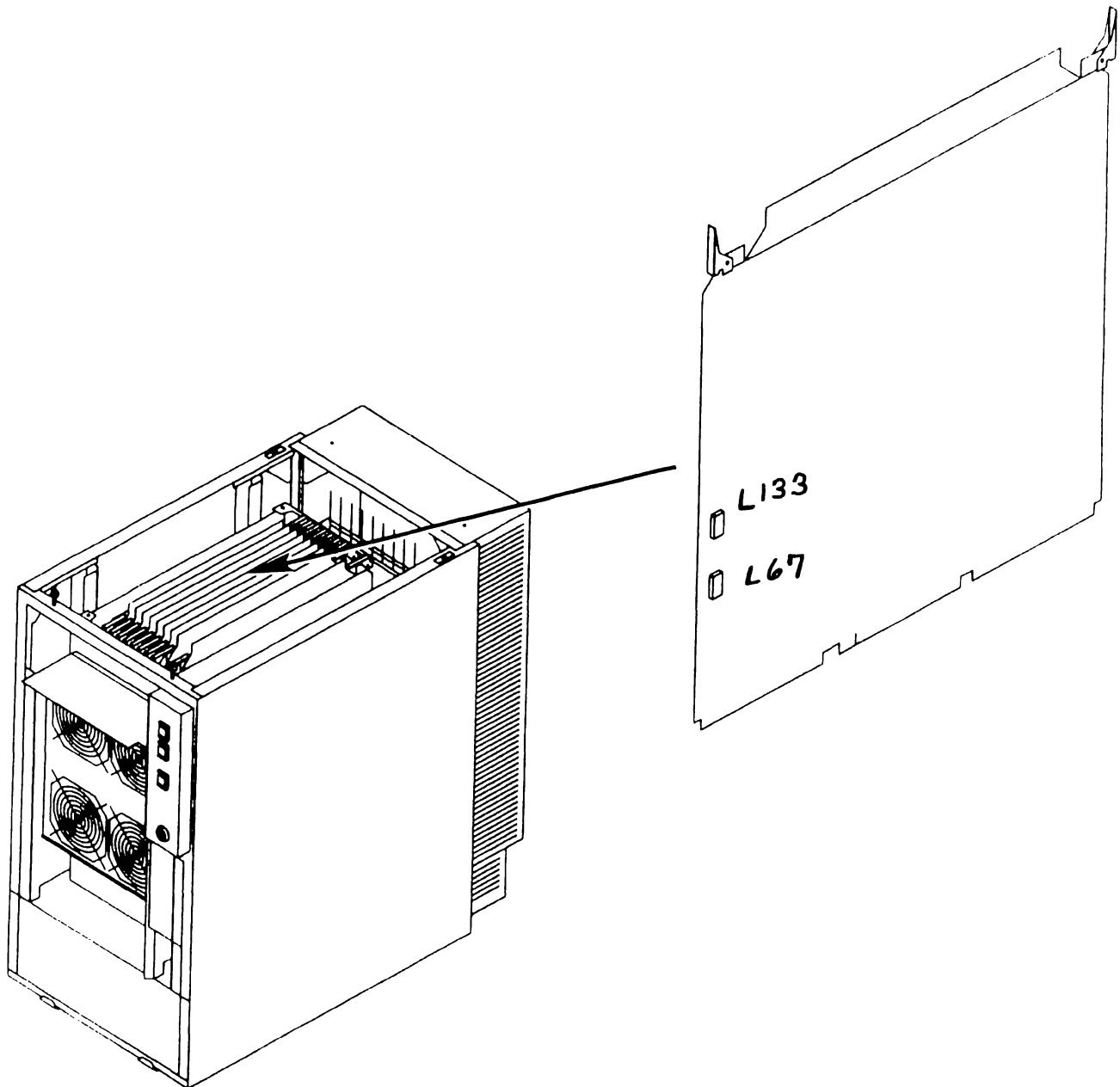

7.2 Removal Procedures

7.2.10 Memory Control Unit (MCU) Removal (Sheet 2 of 2)

5) Verify proper jumper positions of MCU System Address ID jumpers at location L67.

NOTE

MCU Main Memory Size Selection jumpers setting must correspond to the Main Memory board memory configuration. (→ 7.2.11, 7.2.12)

6) Verify proper jumper positions of MCU Support Packet Bus ID jumpers (JP1 - JP3) and Main Memory Size Selection jumpers (JP4 - JP8) at location L133.

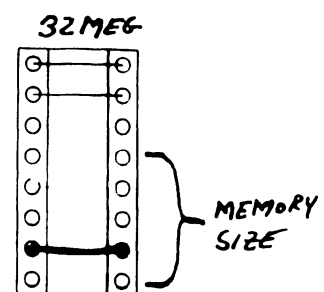
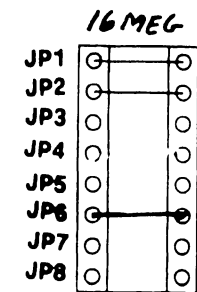
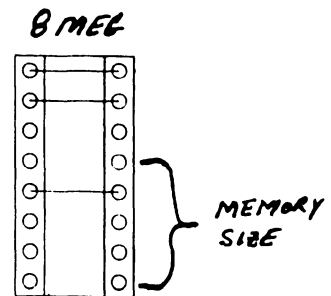
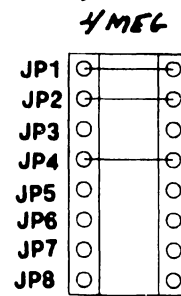
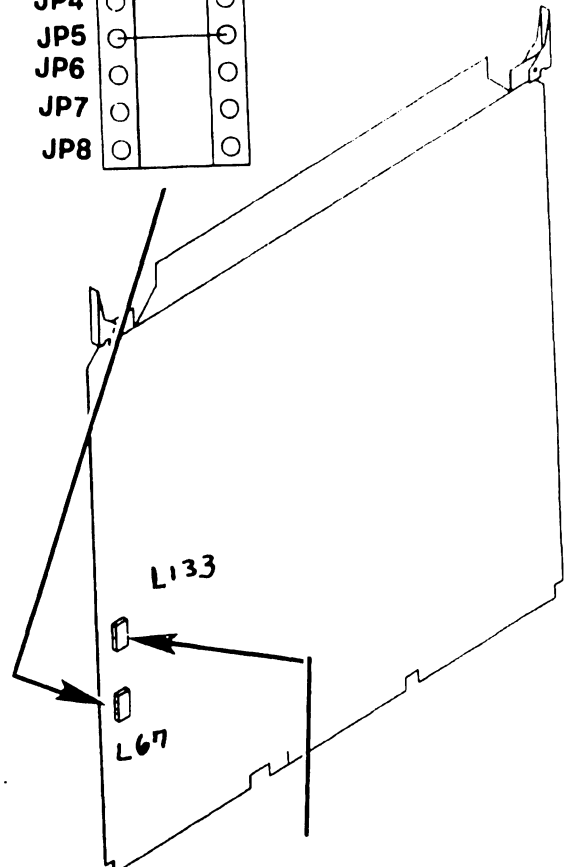
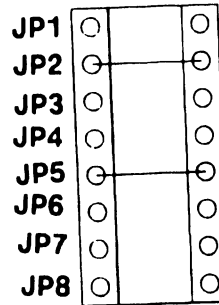
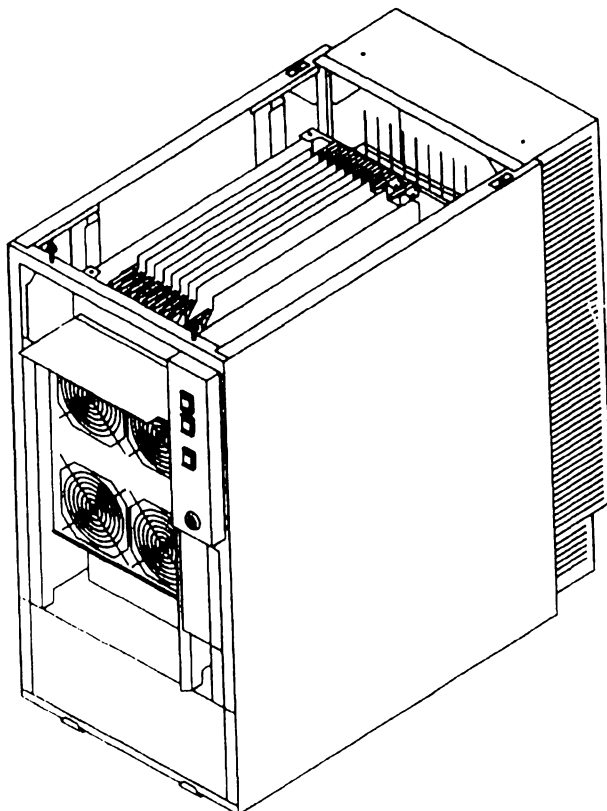

7.2 Removal Procedures

7.2.11 Main Memory (MEM) Board (210-8703/-1) Removal (Sheet 1 of 2)

- 1) Power off mainframe and disconnect ac power. (→4.2)
- 2) Remove top cover. (→7.2.1)
- 3) Remove card cage cover (→7.2.4)
- 4) Remove PCB from backplane. (→ 7.2.5)

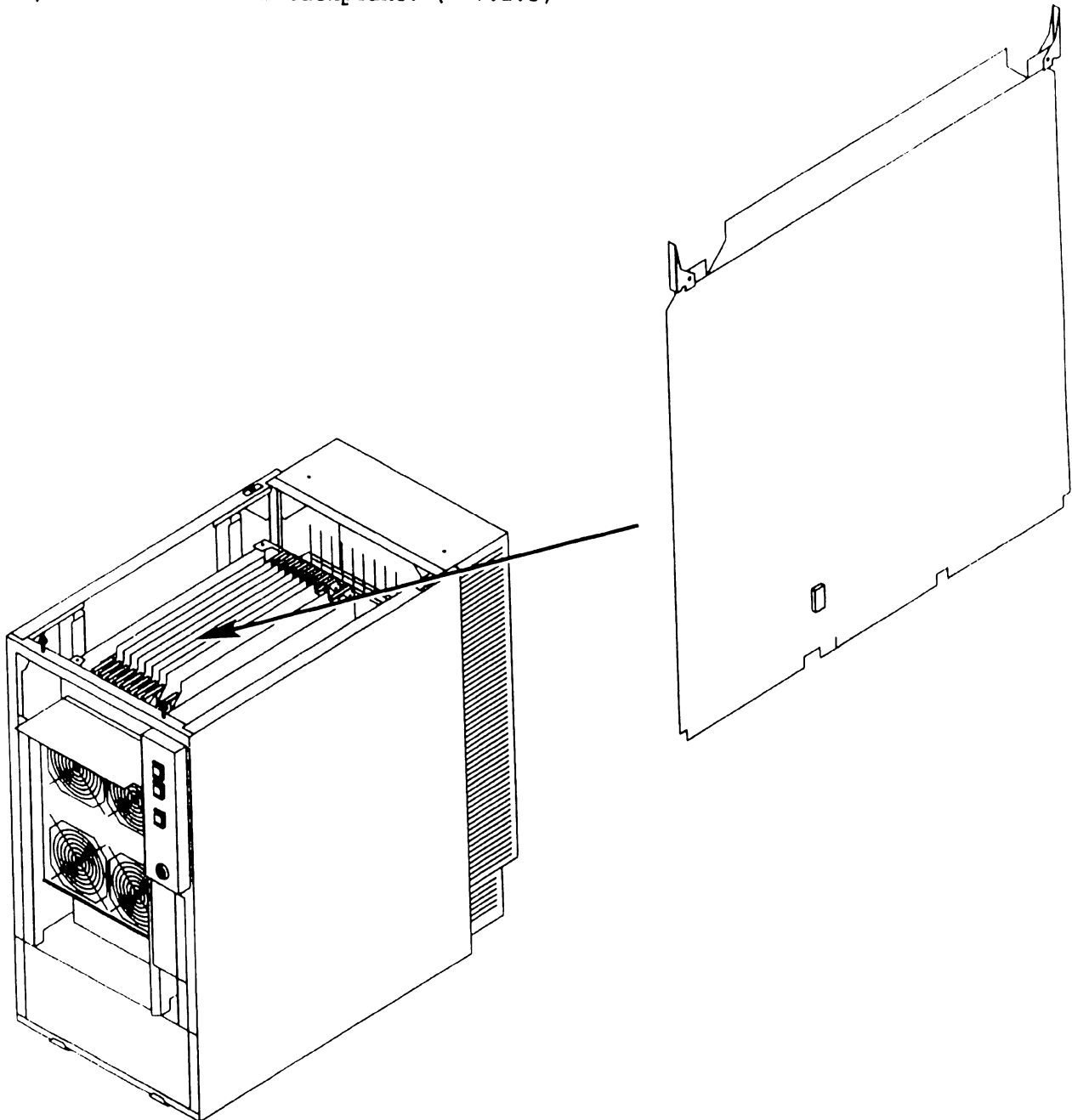

7.2 Removal Procedures

7.2.11 Main Memory (MEM) Board (210-8703/-1) Removal (Sheet 2 of 2)

NOTE

Main Memory board DRAM loading jumper configuration must correspond to the Memory Control Unit Memory Size jumper setting. (~ 7.2.10)

- 5) Verify proper jumper positions of Main Memory DRAM loading jumpers.

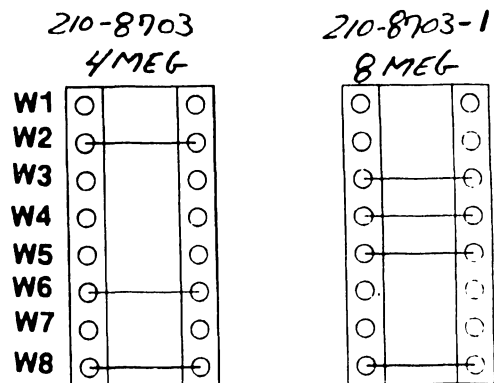
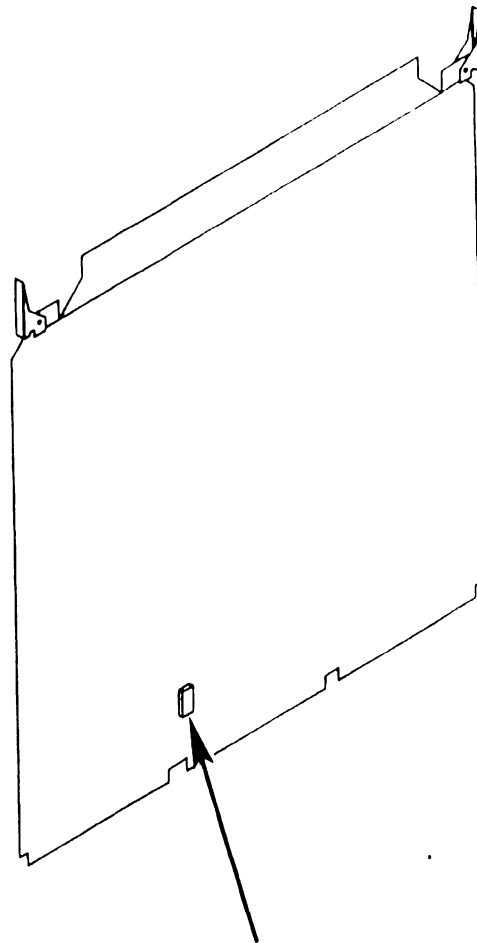
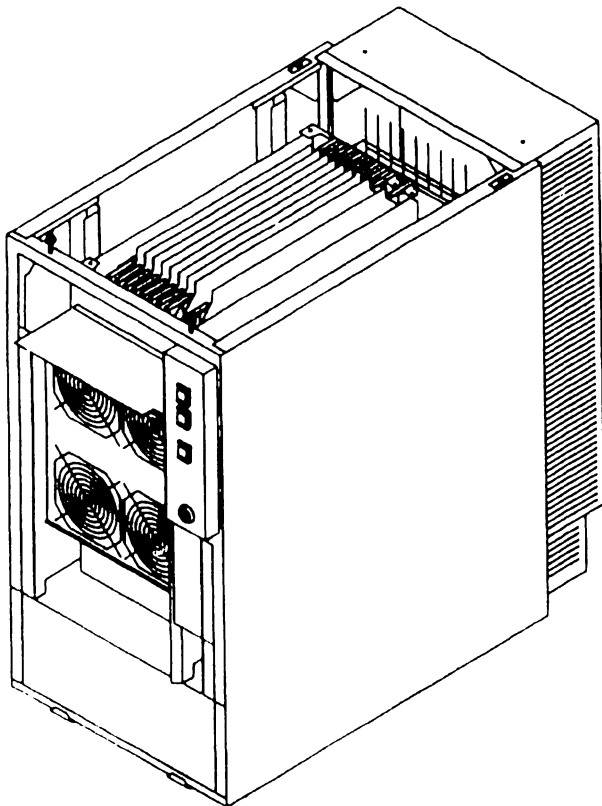

7.2 Removal Procedures

7.2.12 Main Memory (MEM) Board (210-9874/-1) Removal (Sheet 1 of 2)

- 1) Power off mainframe and disconnect ac power. (→4.2)
- 2) Remove top cover. (→7.2.1)
- 3) Remove card cage cover (→7.2.4)
- 4) Remove PCB from backplane. (→ 7.2.5)

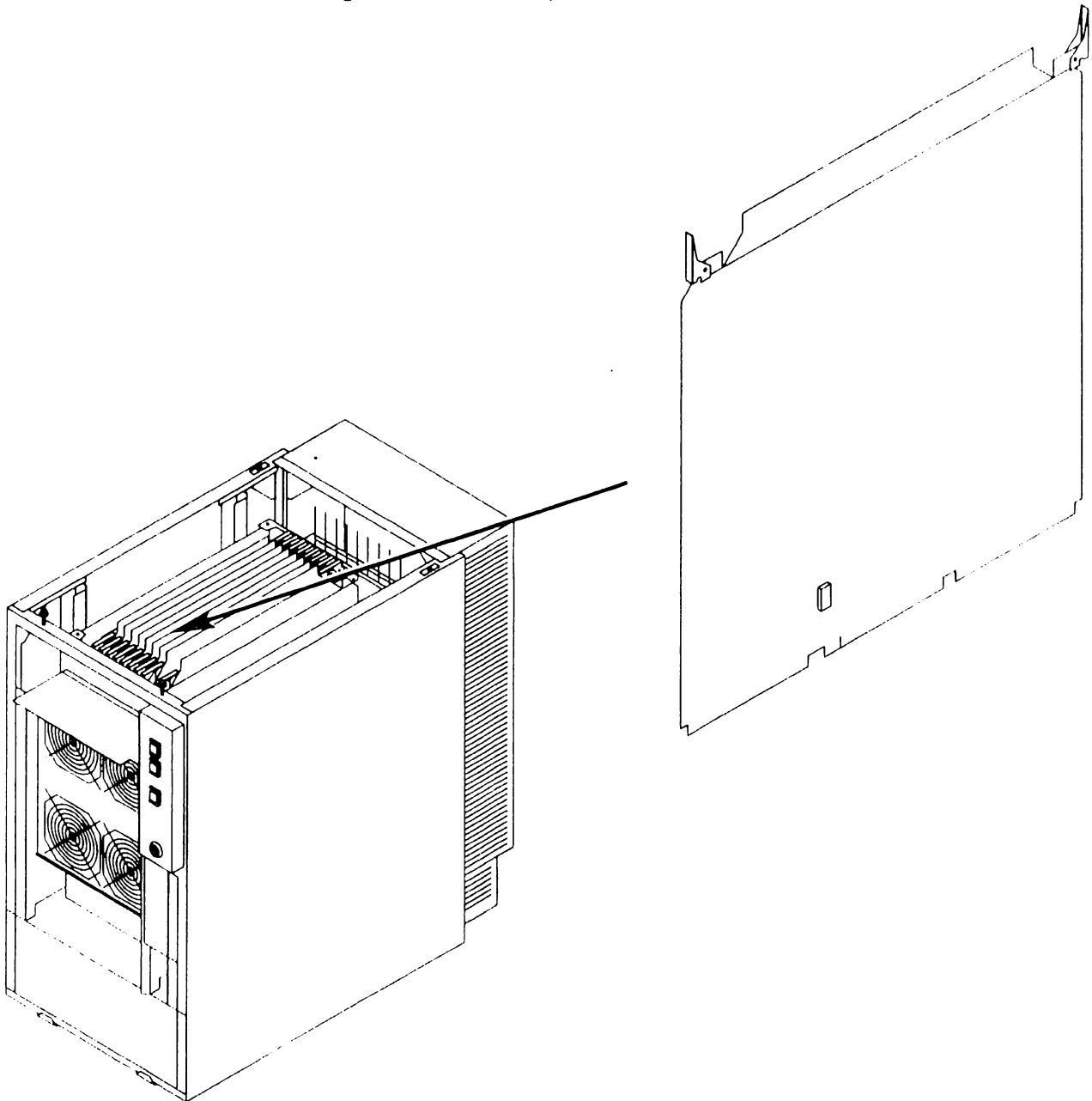

7.2 Removal Procedures

7.2.12 Main Memory (MEM) Board (210-9874/-1) Removal (Sheet 2 of 2)

NOTE

Main Memory board jumper configuration must correspond to the Memory Control Unit Memory Size jumper setting. (→ 7.2.10)

- 5) Verify proper jumper positions of Main Memory DRAM loading jumpers.

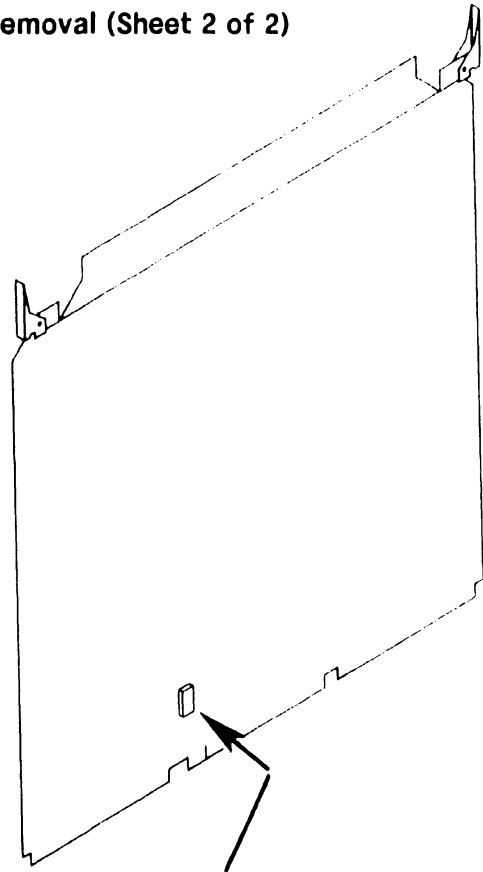
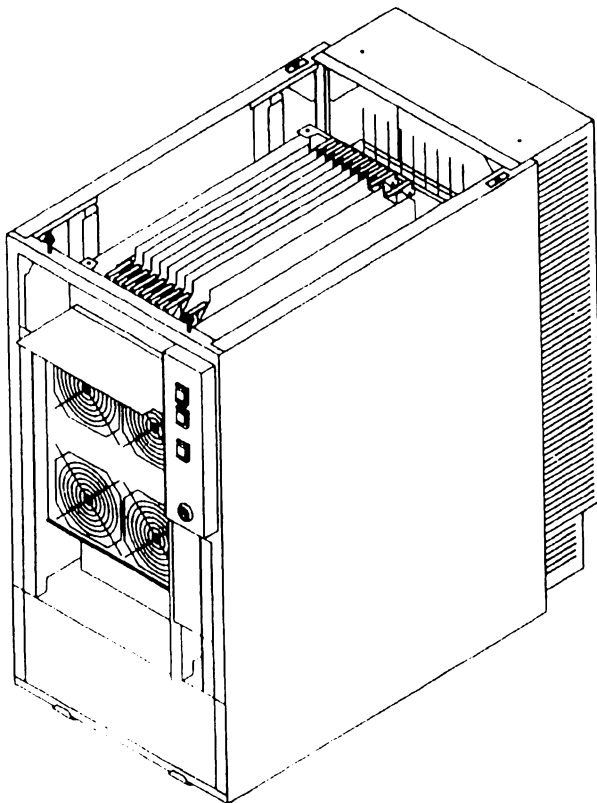

210-9874

16 MEG

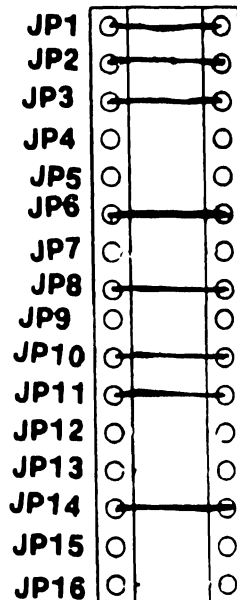

210-9874-1

32 MEG

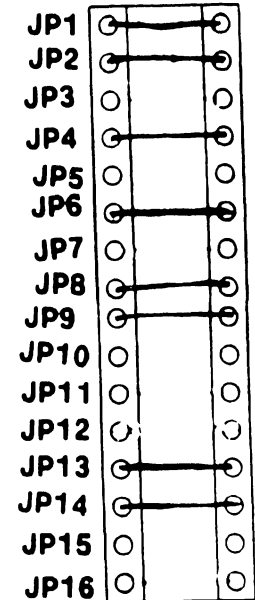

7.2 Removal Procedures

7.2.13 System Bus Interface (SBI) Removal (Sheet 1 of 2)

- 1) Power off mainframe and disconnect ac power. (-4.2)
- 2) Remove top cover. (-7.2.1)
- 3) Remove card cage cover (-7.2.4)
- 4) Remove PCB from backplane. (-7.2.5)
- 5) Verify proper jumper positions of SBI ID jumpers at location L74.

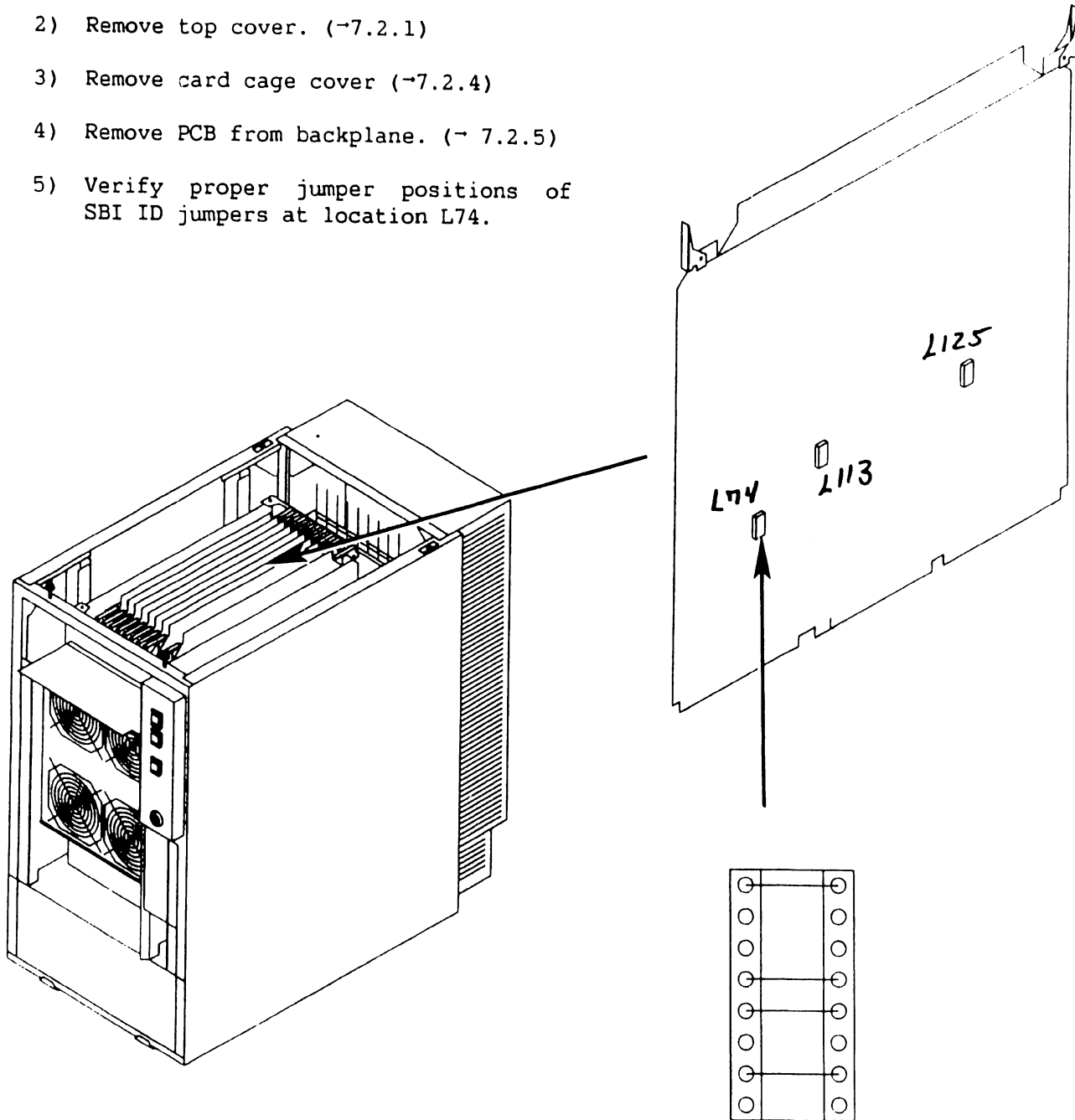

7.2 Removal Procedures

7.2.13 System Bus Interface (SBI) Removal (Sheet 2 of 2)

- 6) Verify proper jumper positions of SPB Target ID jumpers at location L113.
- 7) Verify proper jumper positions of I/O Clock Speed jumpers at location L125.

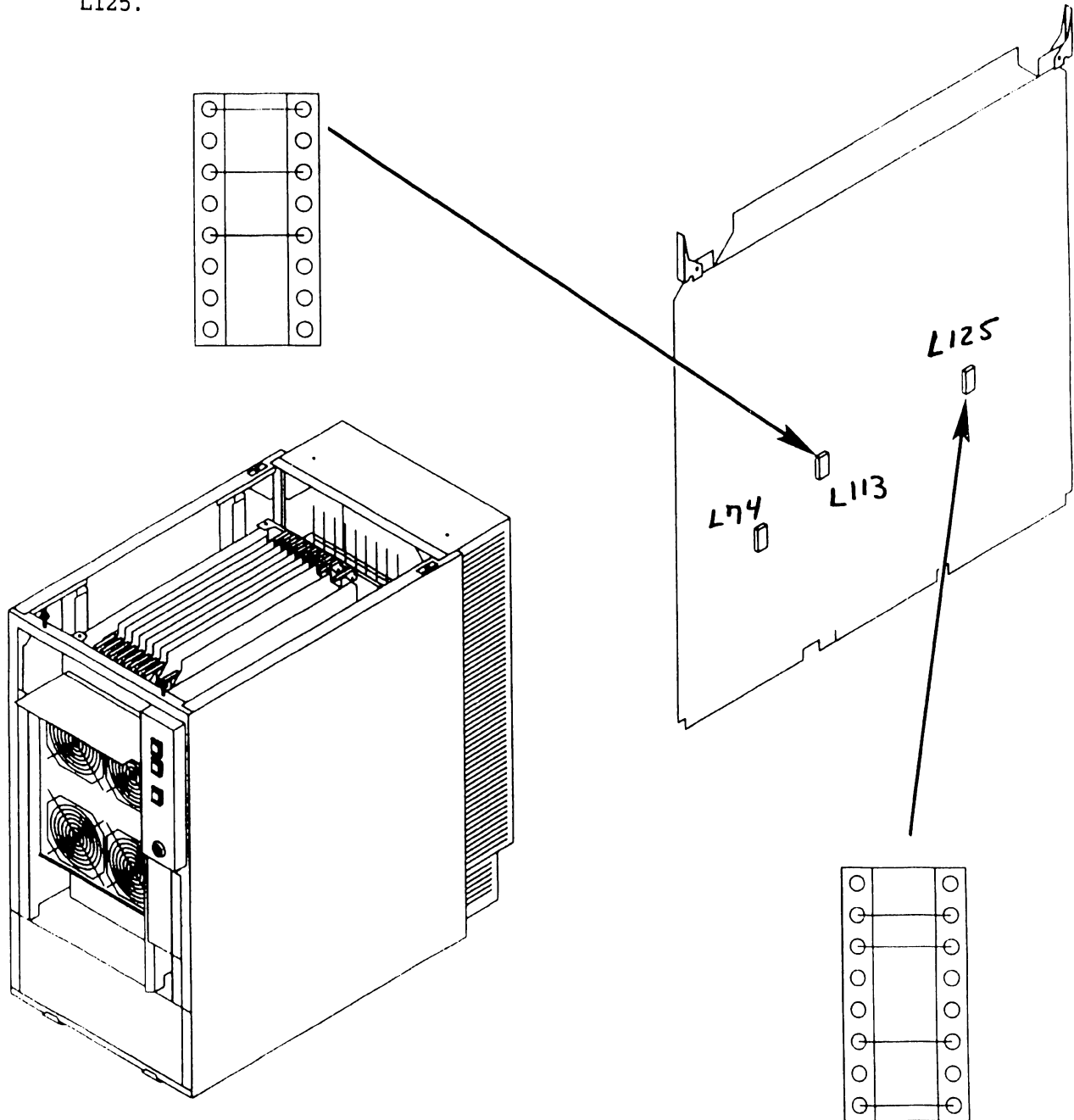

7.2 Removal Procedures

7.2.14 SMD Controller (23V98-4) IOC Removal (Sheet 1 of 3)

- 1) Power off mainframe and disconnect ac power. (-4.2)
- 2) Remove top cover. (-7.2.1)
- 3) Remove card cage cover (-7.2.4)
- 4) Note cable positions and remove 'A' cable from connector J5 and 'B' cables from connectors J4, J3, J2, and J1 (if installed).

NOTE

The first SMD IOC Must Be installed in I/O Slot 1. A second SMD Controller IOC (if used) should be installed in I/O Slot 2.

- 5) Remove PCB from backplane. (-7.2.5)

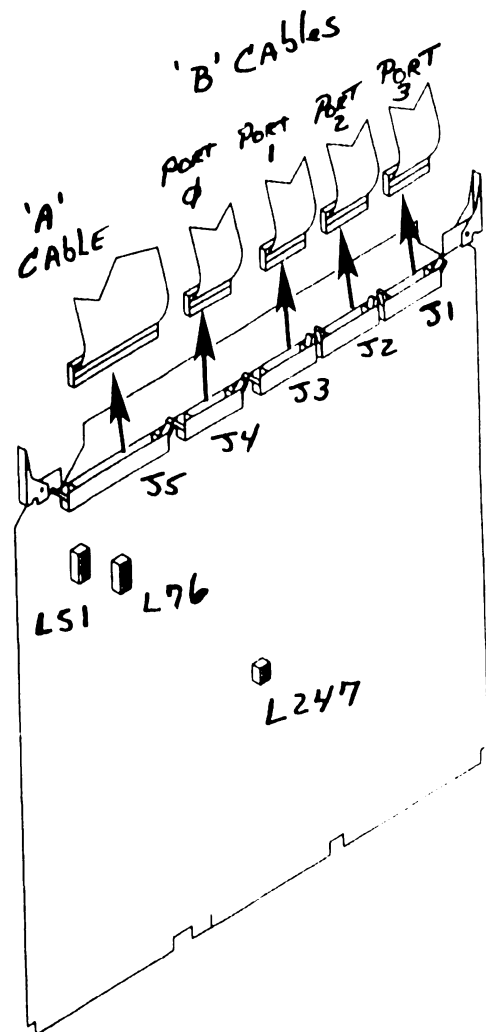
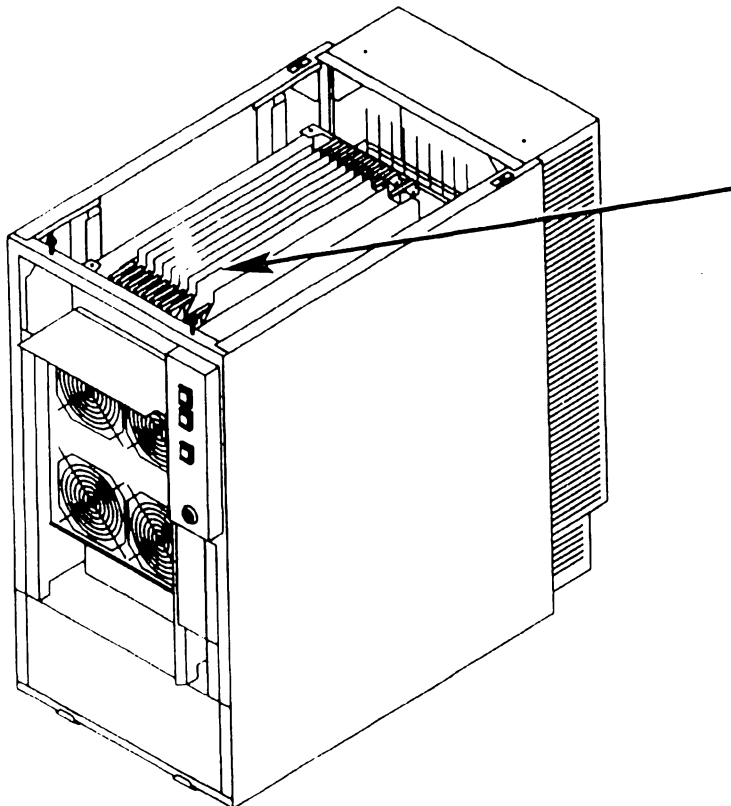

7.2 Removal Procedures

7.2.14 SMD (23V98-4) IOC Removal (Sheet 2 of 3)

6) Verify proper switch positions of Diagnostic switch at location L274.

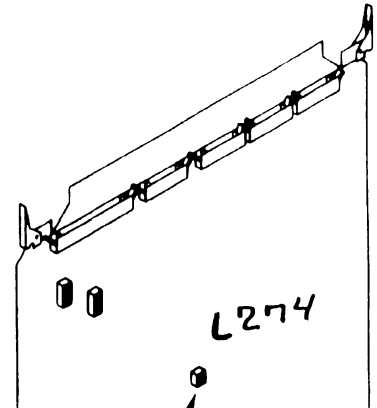
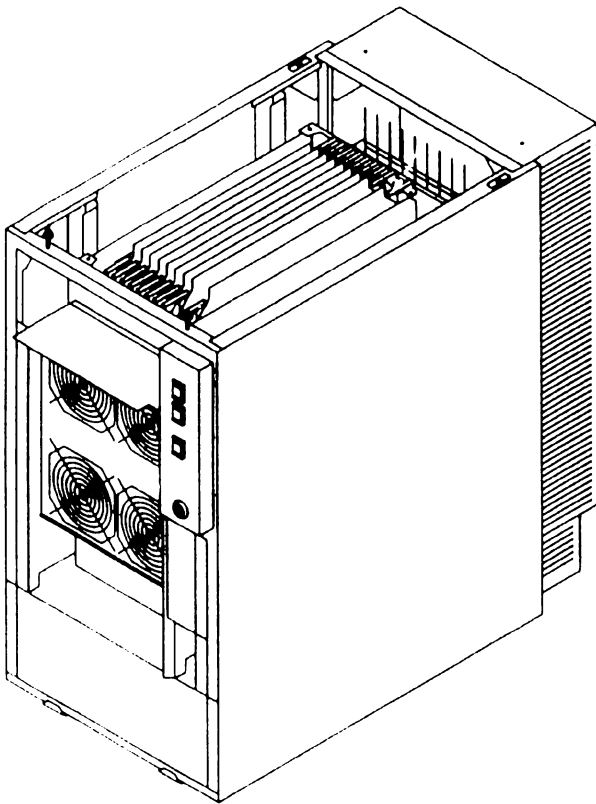

<input checked="" type="checkbox"/>	1	0
<input checked="" type="checkbox"/>	2	0
<input checked="" type="checkbox"/>	3	0
<input checked="" type="checkbox"/>	4	0

= Switch Position
 0 = OPEN CONTACTS
 X = CLOSED CONTACTS

7.2 Removal Procedures

7.2.14 SMD (23V98-4) IOC Removal (Sheet 3 of 3)

7) Verify proper switch settings for drive-types (or no drive) installed on each port; L51 Ports 0 and 1, and L76 Ports 2 and 3.

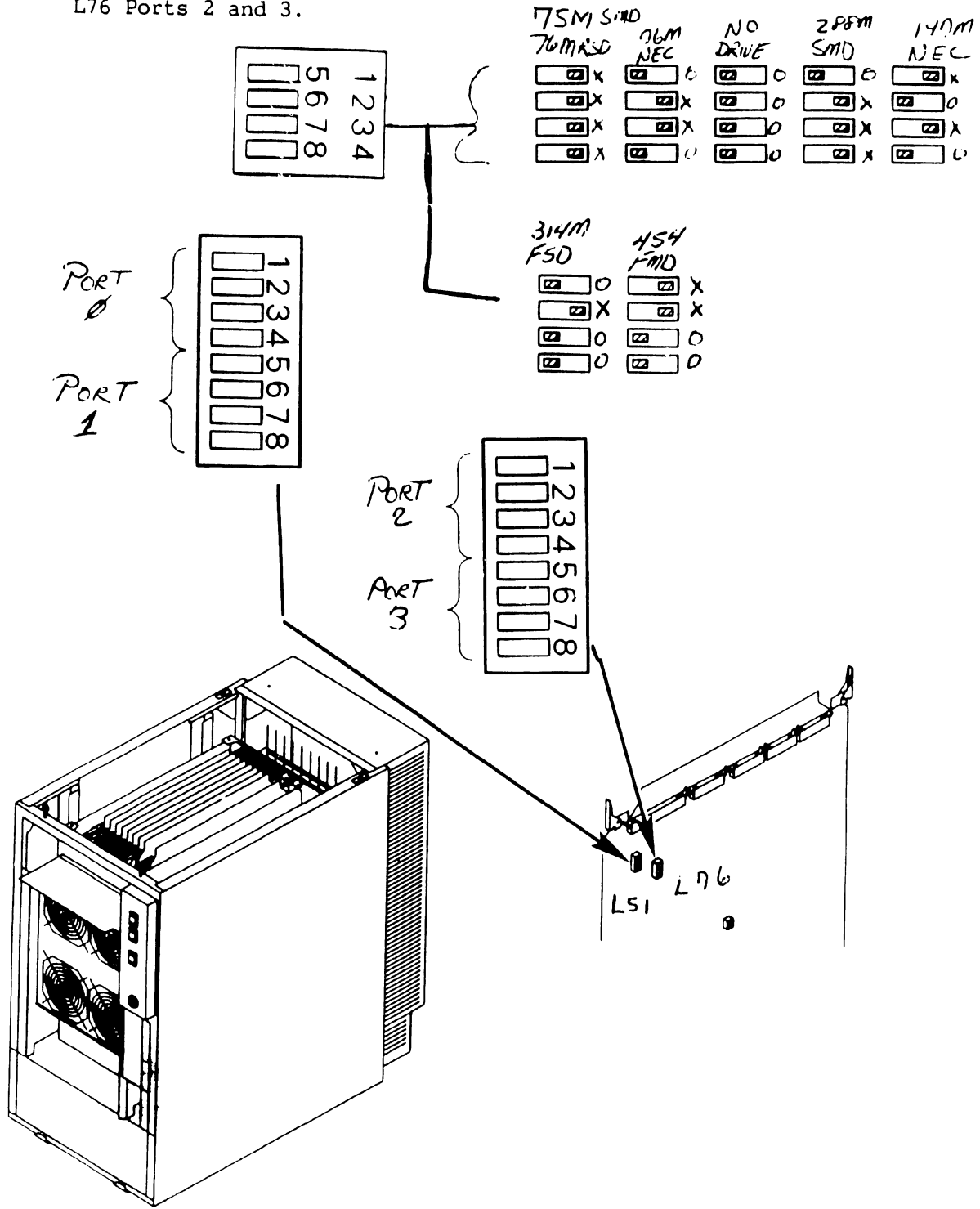

7.2 Removal Procedures

7.2.15 Serial (23V67) IOC Removal (Sheet 1 of 2)

- 1) Power off mainframe and disconnect ac power. (~4.2)
- 2) Remove top cover. (~7.2.1)
- 3) Remove card cage cover (~7.2.4)

NOTE

Serial IOC Connector J1 is reserved for P-Band. No other type of device should be attached.

P-Band Modem must be installed in the cable concentrator due to rear panel bulkhead restrictions.

- 4) Note cable positions and remove 34-pin APA cable from connector J2 and 34-pin P-Band Modem cable from connector J2 (if installed).

NOTE

The first Serial IOC (supporting the SCU (port 0)) Must Be installed in I/O Slot 3. Additional Serial IOCs can be installed in any available I/O slot.

- 5) Remove PCB from backplane. (~ 7.2.5)

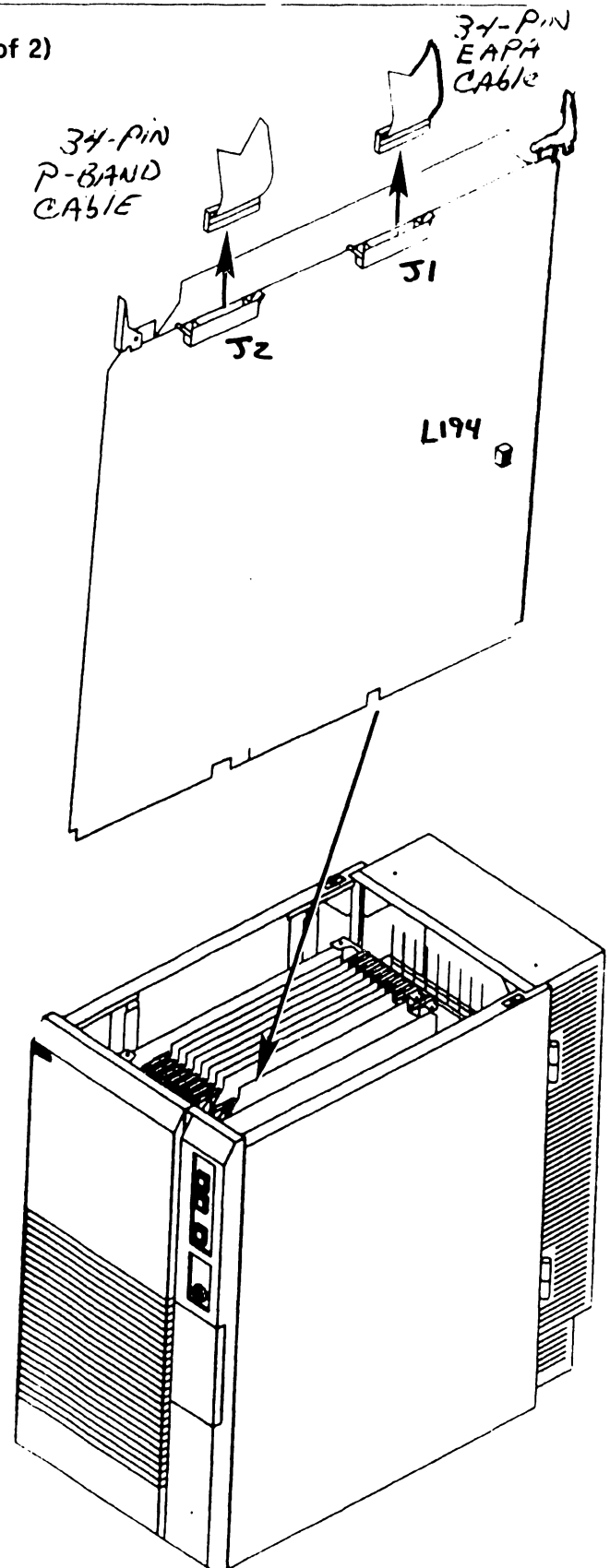

7.2 Removal Procedures

7.2.15 Serial (23V67) IOC Removal (Sheet 2 of 2)

6) Verify proper switch positions of diagnostic switch at location L194.

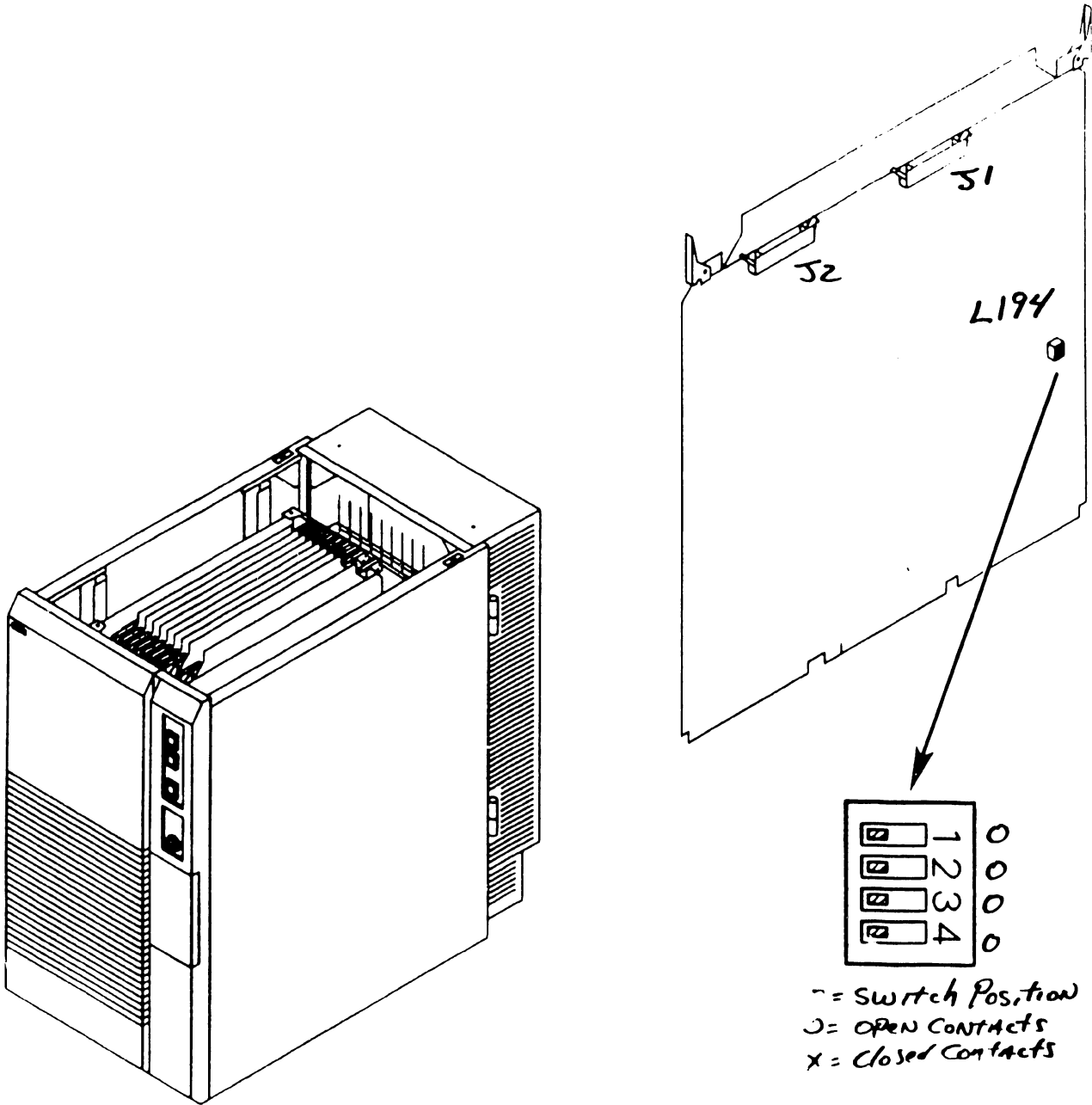

7.2 Removal Procedures

7.2.16 Kennedy Tape (23V95-1) IOC Removal (Sheet 1 of 2)

- 1) Power off mainframe and disconnect ac power. (~4.2)
- 2) Remove top cover. (~7.2.1)
- 3) Remove card cage cover (~7.2.4)
- 4) Note cable positions and remove 50-pin data cable from connector J1 and 50-pin control cable from connector J2.
- 5) Remove PCB from backplane. (~ 7.2.5)

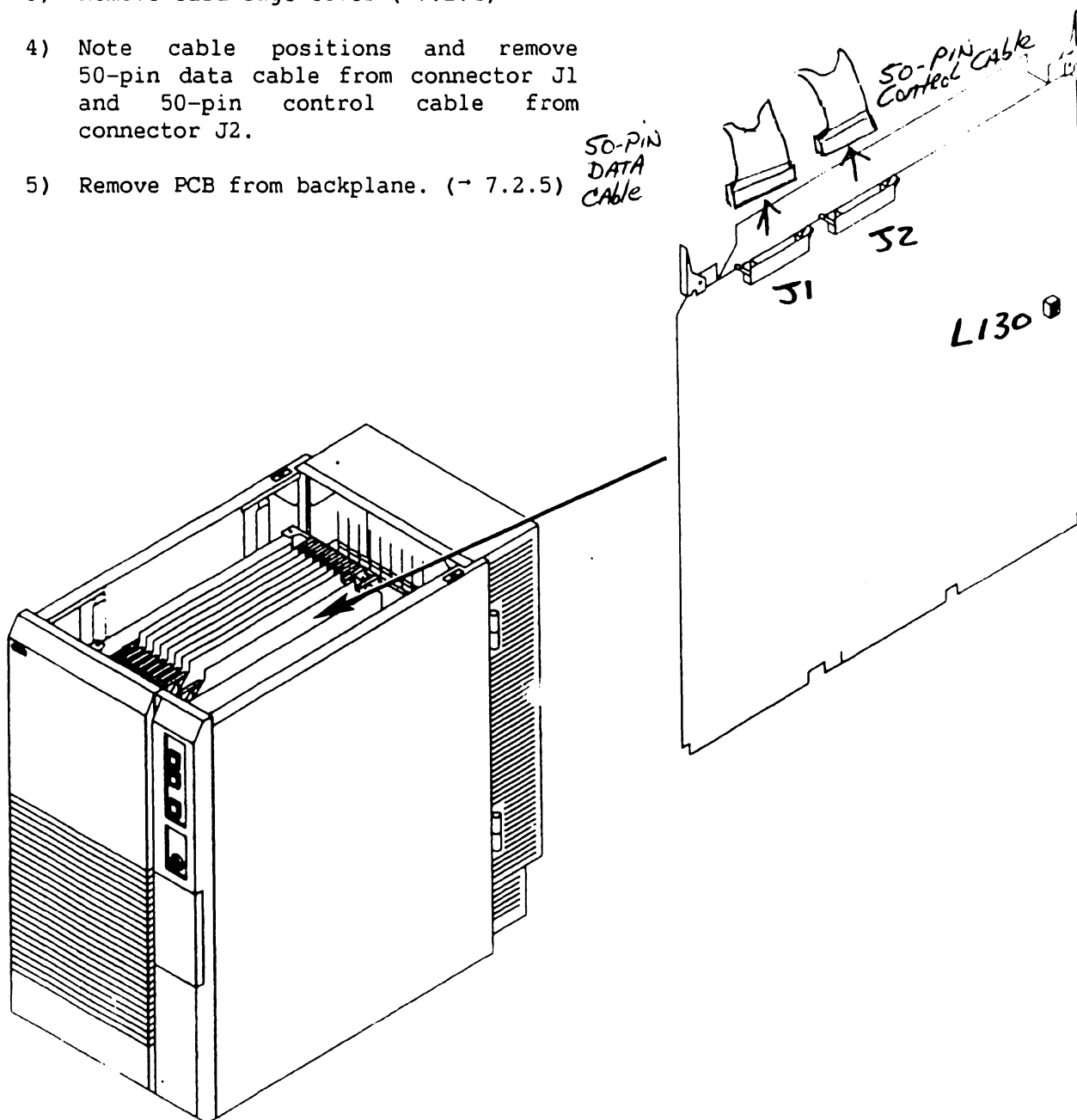

7.2 Removal Procedures

7.2.16 Kennedy Tape (23V95-1) IOC Removal (Sheet 2 of 2)

- 6) Verify proper switch positions of diagnostic switch at location L130.

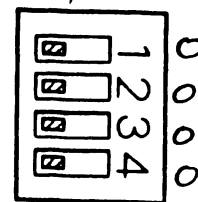
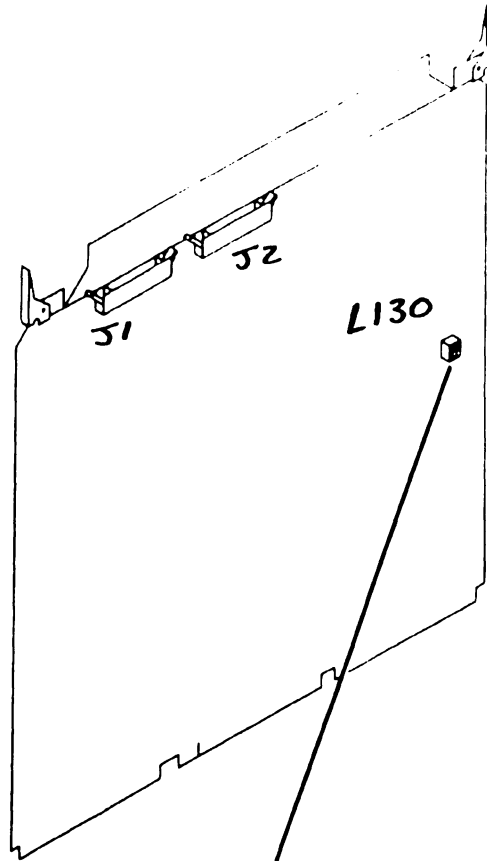
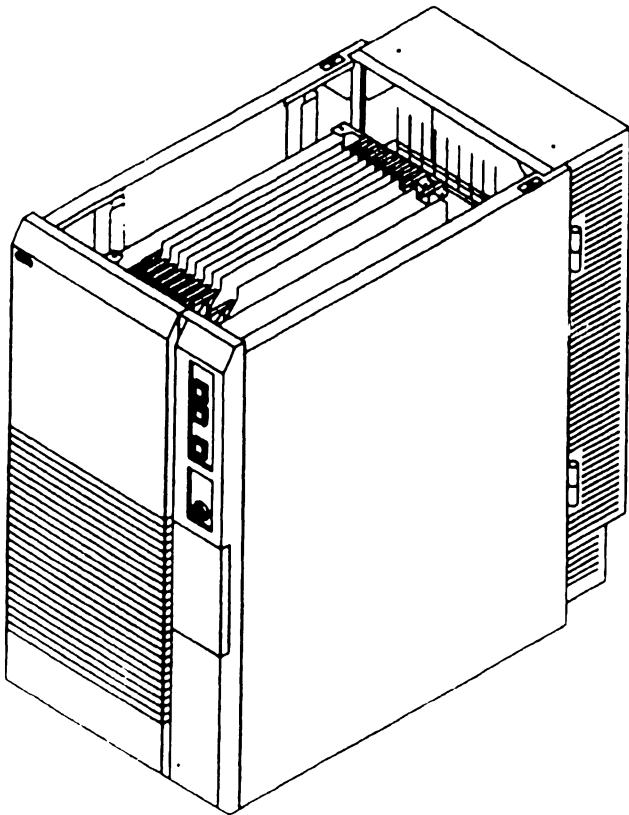

X = Switch Position
O = Open Contacts
X = Closed Contacts

7.2 Removal Procedures

7.2.17 Telex Tape (23V95-2) IOC Removal (Sheet 1 of 2)

- 1) Power off mainframe and disconnect ac power. (→4.2)
- 2) Remove top cover. (→7.2.1)
- 3) Remove card cage cover (→7.2.4)
- 4) Note cable positions and remove 50-pin status cable from connector J3, 50-pin data cable from connector J2, and 50-pin control cable from connector J1.
- 5) Remove PCB from backplane. (→ 7.2.5)

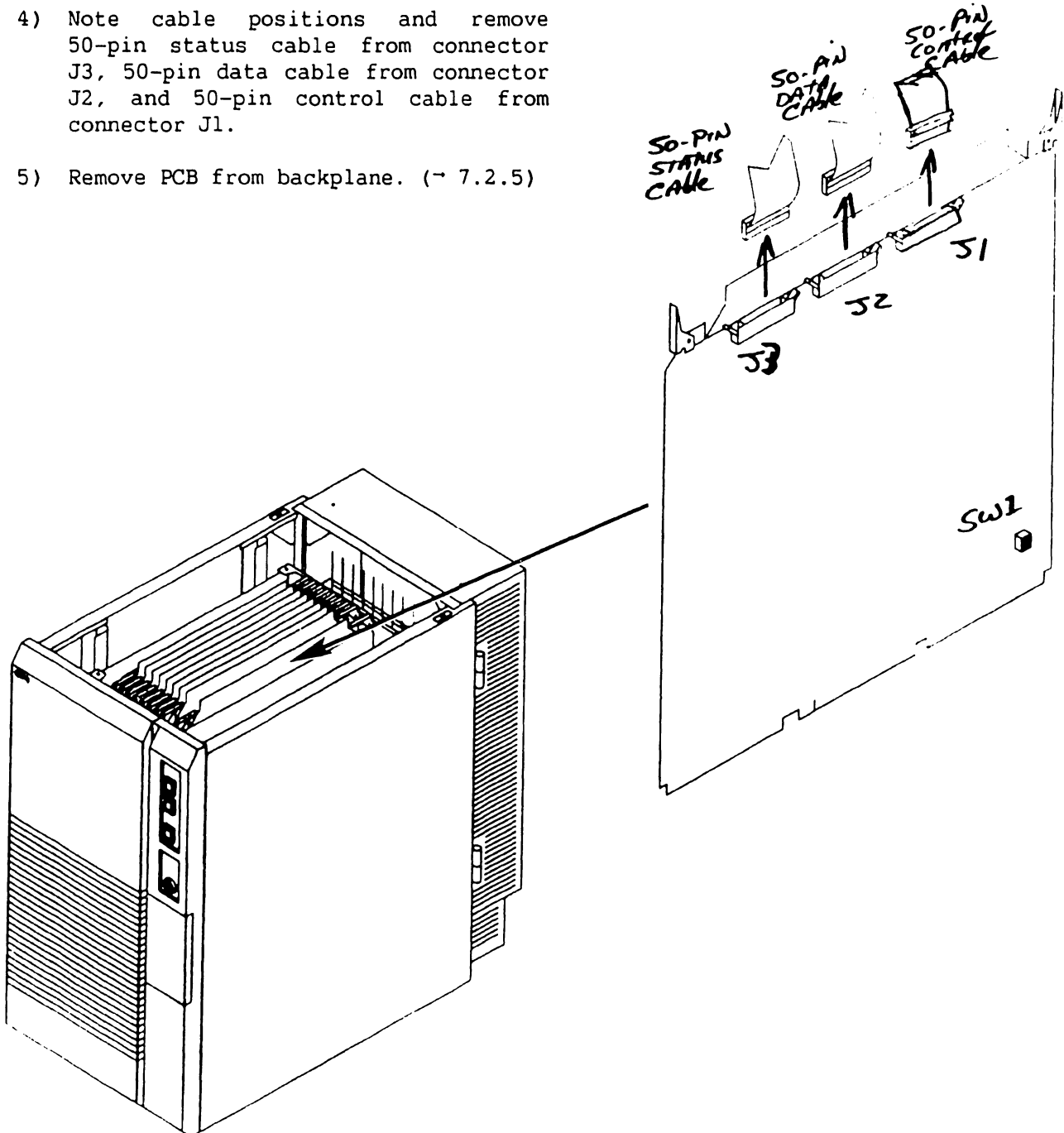

7.2 Removal Procedures

7.2.17 Telex Tape (23V95-2) IOC Removal (Sheet 2 of 2)

- 6) Verify proper switch positions of diagnostic switch at location SW1.

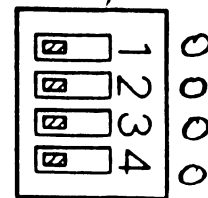
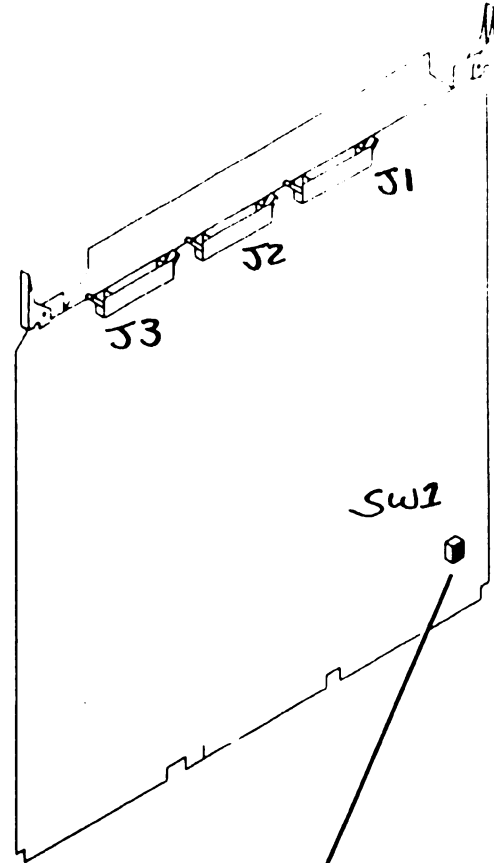
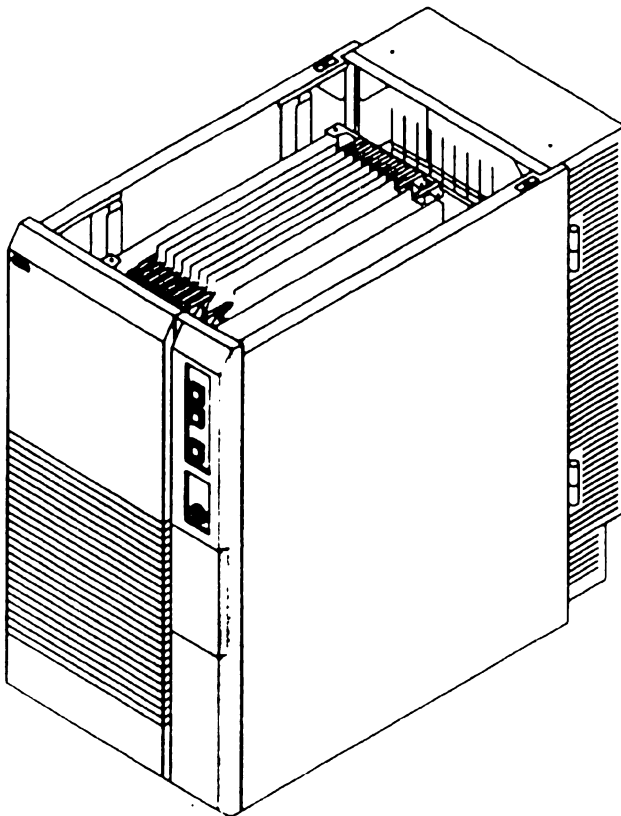

= Switch Position
O = Open Contacts
X = Closed Contacts

7.2 Removal Procedures

7.2.18 Multiline TC (23V86/96) IOC Removal (Sheet 1 of 2)

- 1) Power off mainframe and disconnect ac power. (~4.2)
- 2) Remove top cover. (~7.2.1)
- 3) Remove card cage cover (~7.2.4)
- 4) Note cable positions and remove 50-pin Port 0-3 cable from connector J1, 50-pin Port 4-7 cable from connector J2, 50-pin Port 8-11 cable from connector J3, and 50-pin Port 12-15 cable from connector J4 (if installed).
- 5) Remove PCB from backplane. (~ 7.2.5)

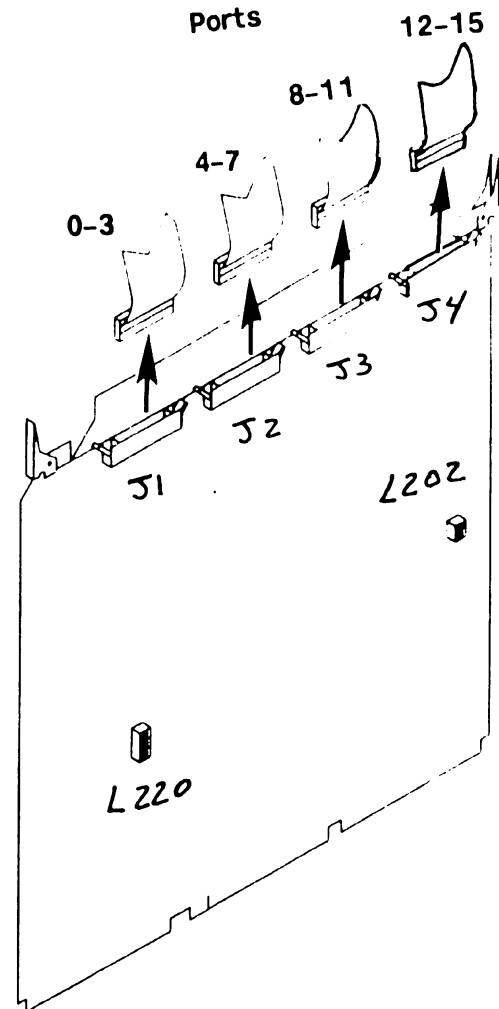
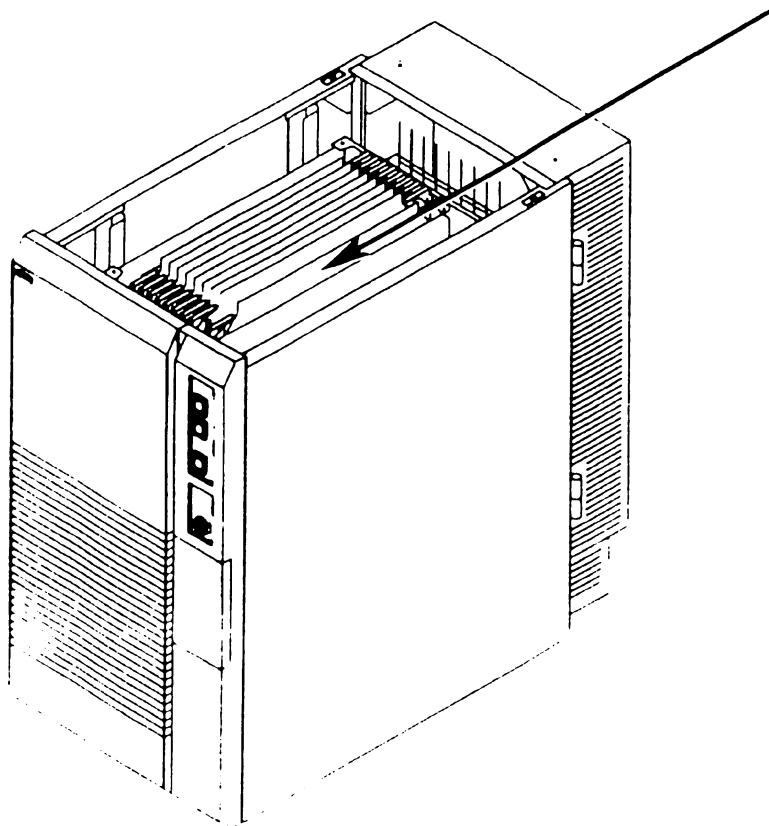

7.2 Removal Procedures

7.2.18 Multiline TC (23V86/96) IOC Removal (Sheet 2 of 2)

- 6) Verify proper switch positions of diagnostic switch at location L202.
- 7) Verify proper switch positions of diagnostic port select switch at location L220.

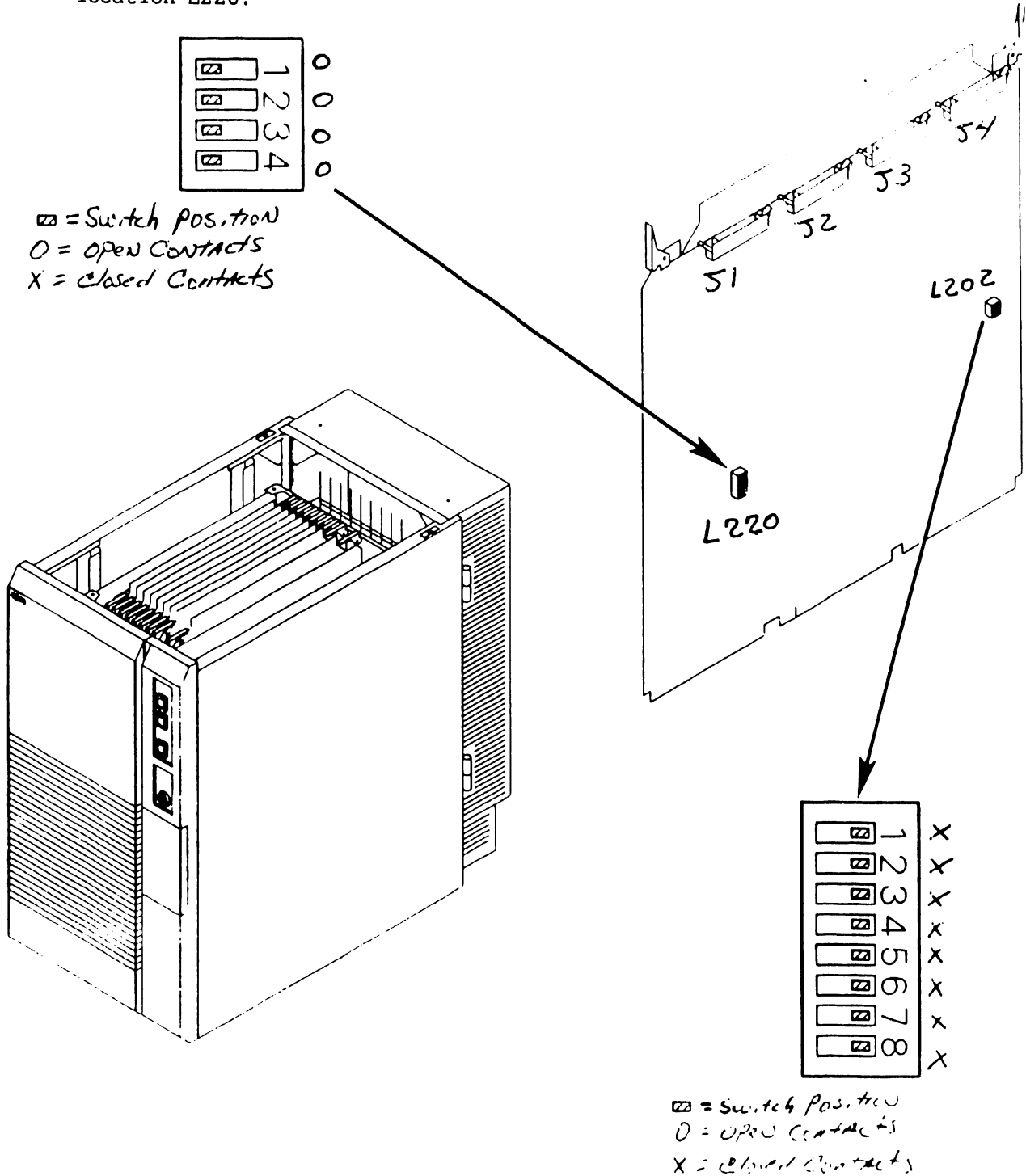

7.2 Removal Procedures

7.2.19 Power Supply Controller Board Removal (Sheet 1 of 3)

- 1) Power off mainframe and disconnect ac power. (-4.2)
- 2) Remove top cover. (-7.2.1)
- 3) Remove front cover. (-7.2.2)
- 4) Remove right side cover. (-7.2.3)
- 5) Remove 9-pin cable from connector J1, 4-pin cable from connector J3, 60-pin cable from connector J6, 20-pin cable from connector J7, and 5-pin cable from connector J9.

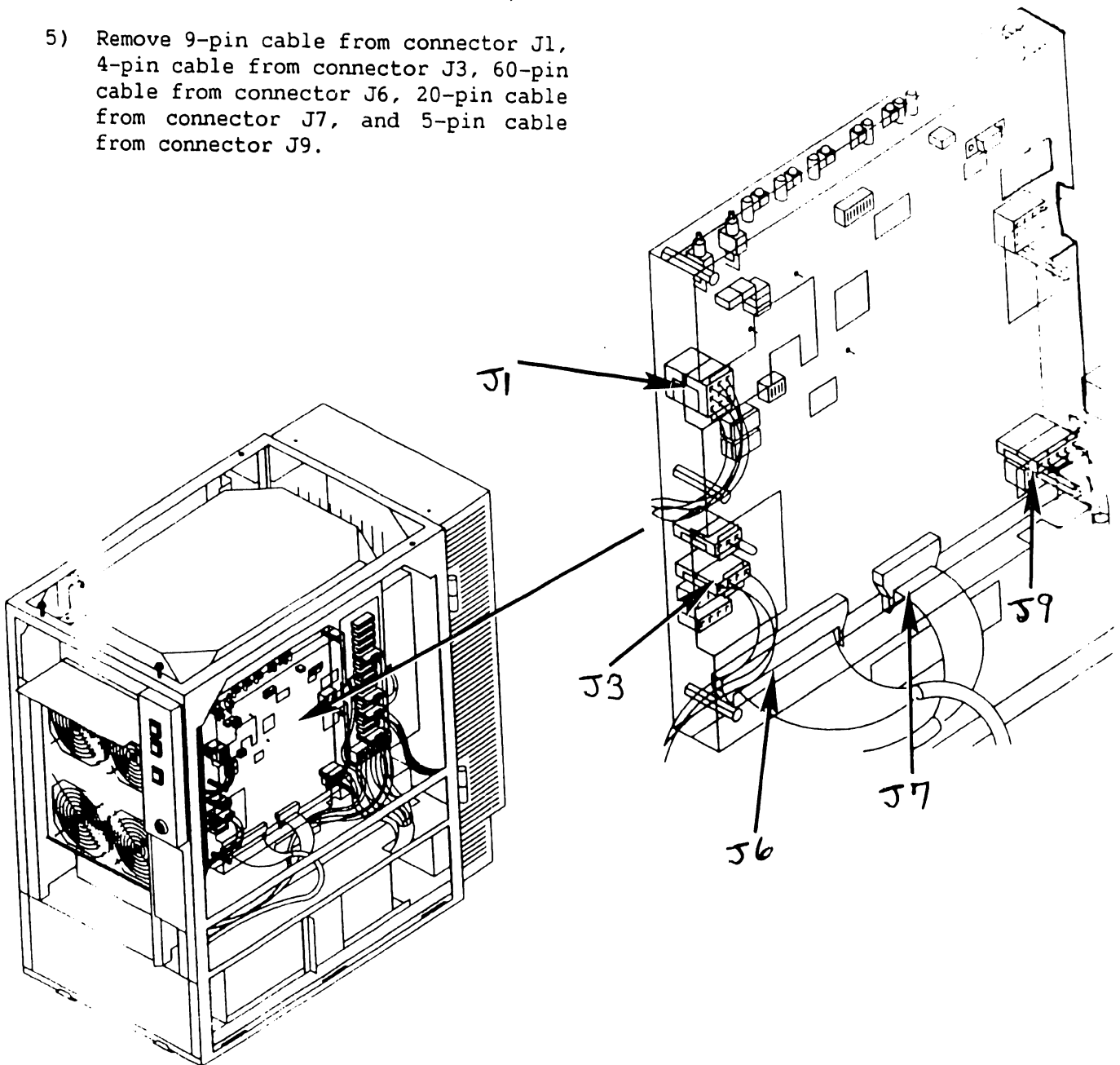

7.2 Removal Procedures

7.2.19 Power Supply Controller Board Removal (Sheet 2 of 3)

- 6) Remove six screws securing power supply controller board shield in place.

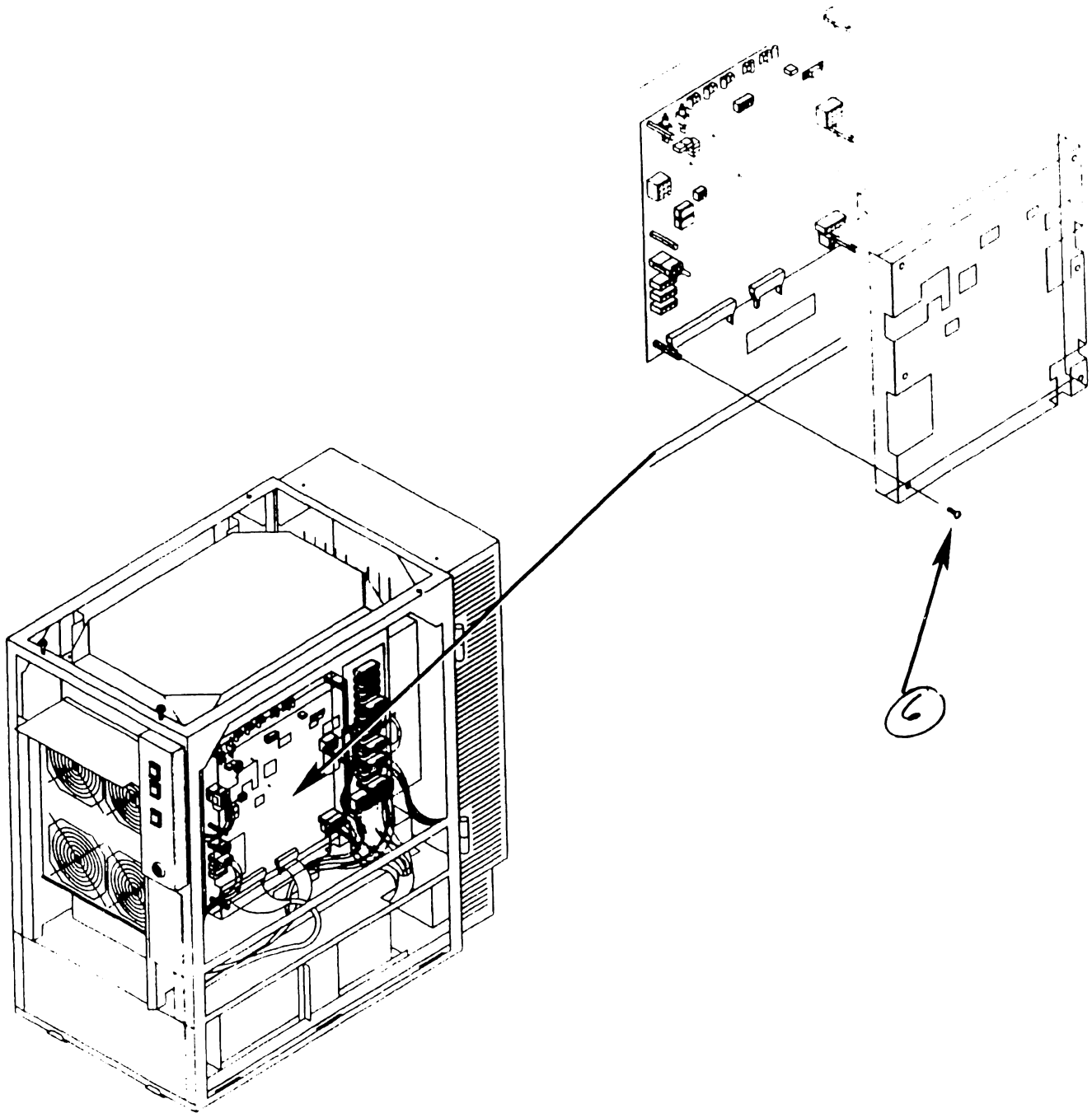

7.2 Removal Procedures

7.2.19 Power Supply Controller Board Removal (Sheet 3 of 3)

- 7) Remove six threaded stand-offs securing power supply controller board to card cage.
- 8) Remove Power Supply Controller board.

NOTE

Power Supply Controller Board contains two switch banks; SW3 and SW4.

Switch SW3 A/D Converter Voltage Address switch will be set to the last A/D Converter voltage address adjusted. (-8.2.2)

Switch SW4 is not used. Disregard any switch settings.

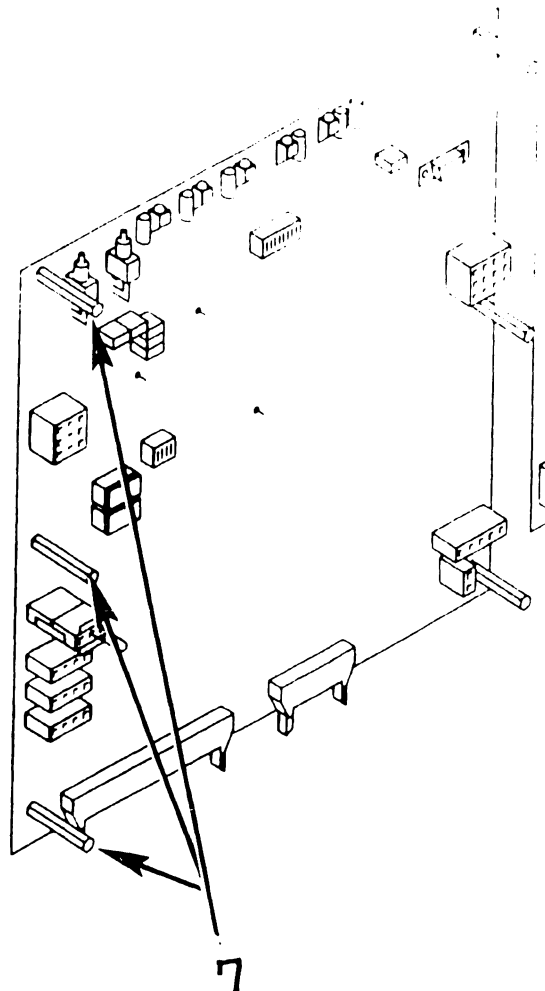
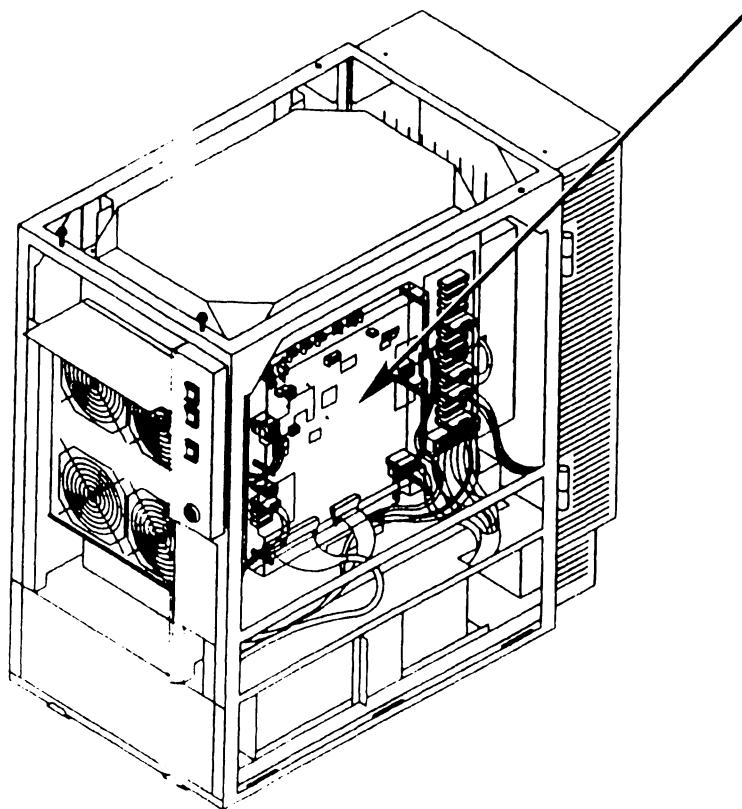

7.2 Removal Procedures

7.2.20 DC Power Distribution Unit (DC PDU) Removal (Sheet 1 of 3)

- 1) Power off mainframe and disconnect ac power. (-4.2)
- 2) Remove top cover. (-7.2.1)
- 3) Remove front cover. (-7.2.2)
- 4) Remove right side cover. (-7.2.3)

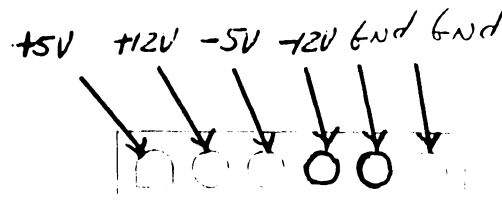
**NOTE**

DC PDU connectors J1 - J15 are in parallel. DC power cables can be installed in any available connector location.

- 5) Remove all cables from DC PDU connectors (i.e. front fan assembly cable, rear fan assembly cable, option half-panel cables).

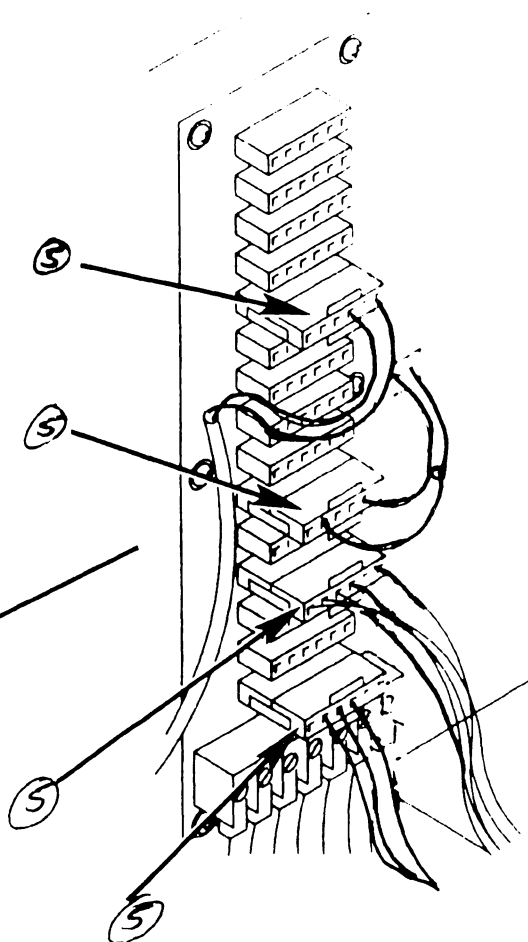
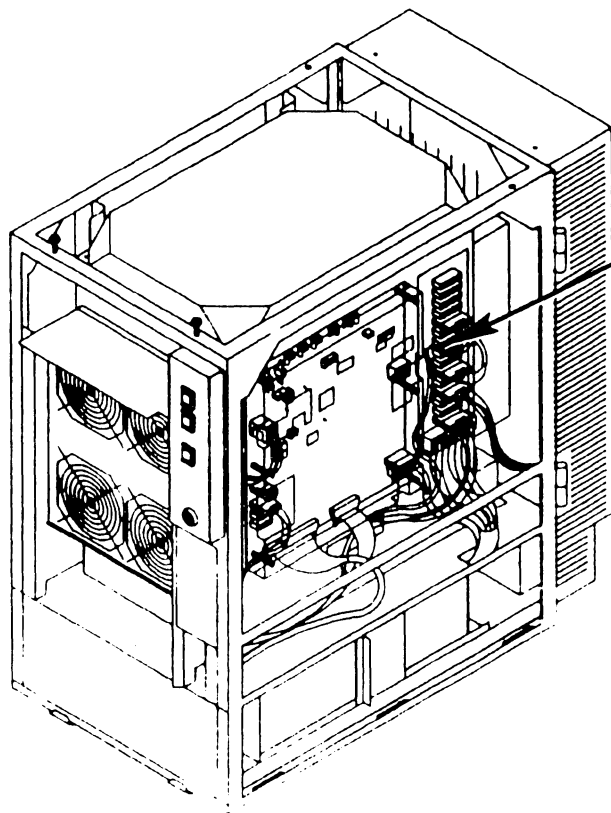

7.2 Removal Procedures

7.2.20 DC Power Distribution Unit (DC PDU) Removal (Sheet 2 of 3)

- 6) Note wire locations and color code and remove DC Power harness assembly from DC PDU 7-connector terminal block.

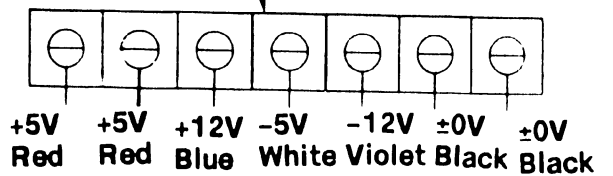
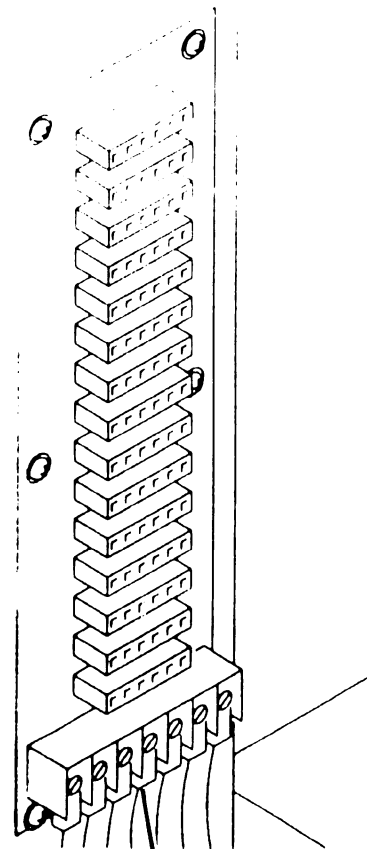
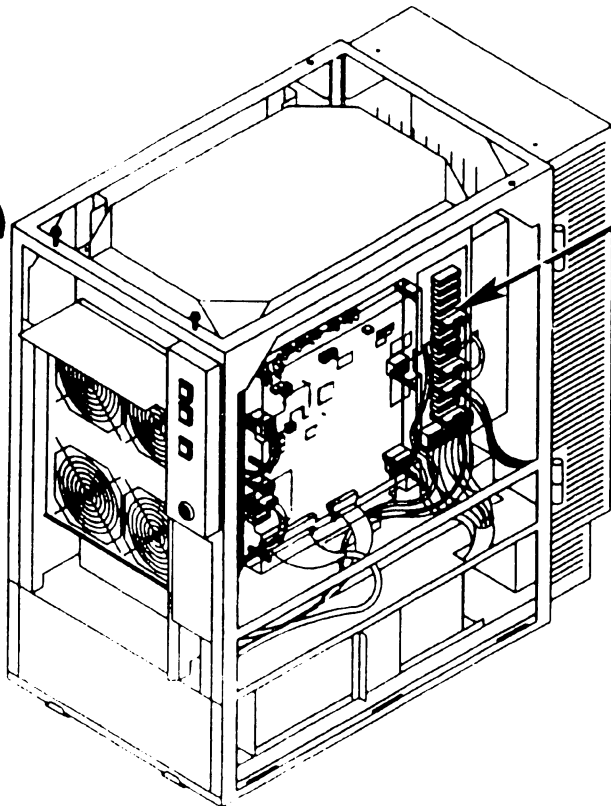

7.2 Removal Procedures

7.2.20 DC Power Distribution Unit (DC PDU) Removal (Sheet 3 of 3)

- 7) Remove six screws securing DC PDU to card cage.
- 8) Remove DC PDU.

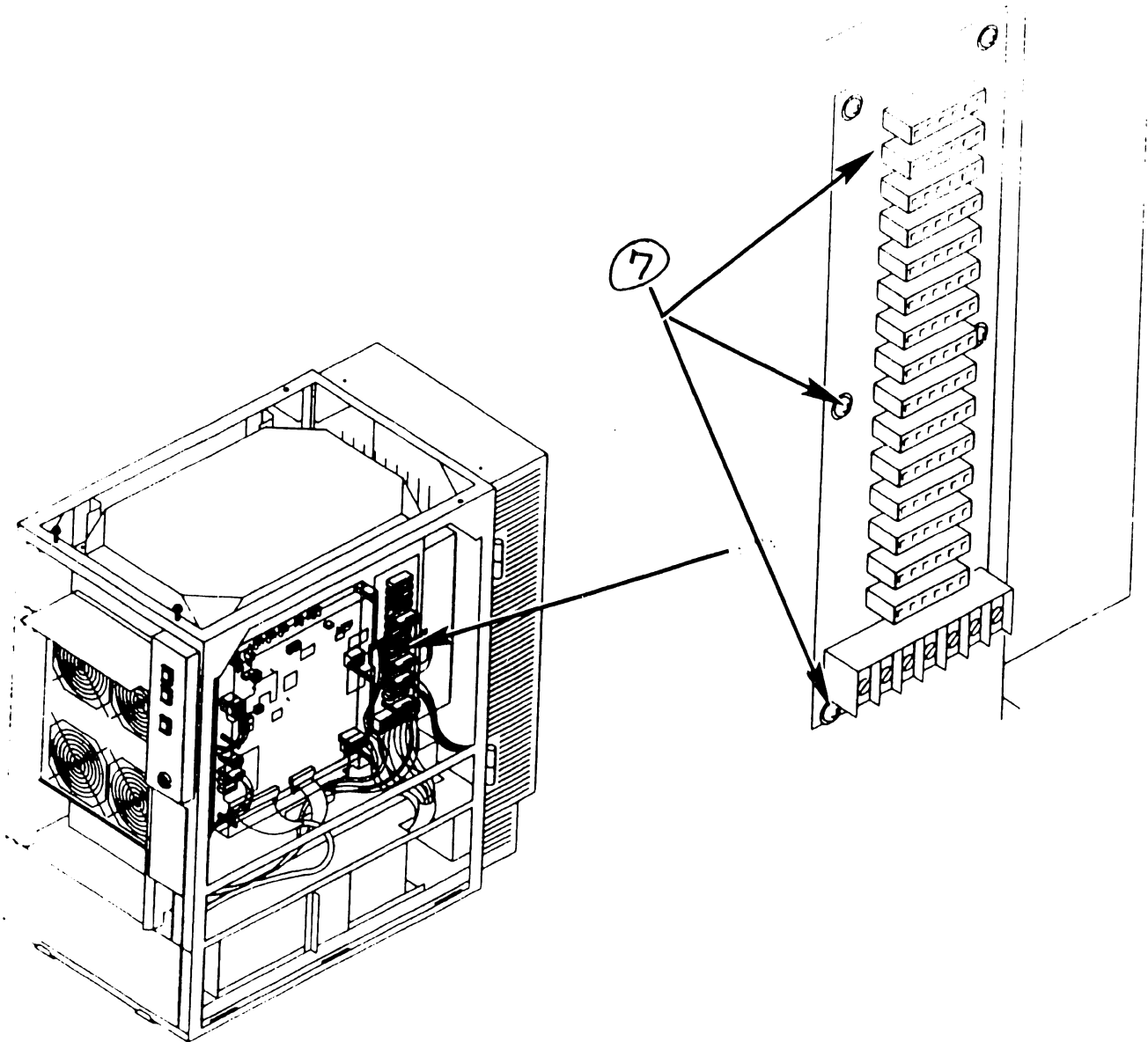

SECTION

8

ADJUSTMENTS

SECTION 8
ADJUSTMENTS

		<u>Page</u>
8.1	TOOLS AND EQUIPMENT	8-1
8.1.1	Special Tools	8-1
8.2	ELECTRICAL ADJUSTMENTS	8-2
8.2.1	Multioutput Power Supply Voltage Adjustments	8-2
8.2.2	Power Supply Controller Adjustments	8-6

8.1 Tools And Equipment

8.1.1 Special Tools

All adjustments can be accomplished using a standard Wang CE tool kit which includes:

- Small flat blade plastic screwdriver
- Digital multimeter

One special tool is required for power supply testing:

- Power supply test plug 220-2342

8.2 Electrical Adjustments

8.2.1 Multioutput Power Supply Voltage Adjustments (sheet 1 of 4)

WARNING

DO NOT OPEN SWITCHING POWER SUPPLY UNDER ANY CIRCUMSTANCE. EXTREMELY DANGEROUS VOLTAGE AND CURRENT LEVELS, IN EXCESS OF 300 VOLTS DC AND UNLIMITED CURRENT, ARE PRESENT WITHIN POWER SUPPLY. DO NOT ATTEMPT TO REPAIR POWER SUPPLY; IT IS FIELD REPLACEABLE ONLY.

- 1) Power down mainframe. (→ 4.2)
- 2) Remove top cover. (→ 7.2.1)
- 3) Remove front cover. (→ 7.2.2)
- 4) Remove left side cover. (→ 7.2.3)
- 5) Remove AC PDU from chassis and swing it to the left as far as the cables allow. (→ 7.2.2.3)
- 6) Power-on mainframe using power supply controller board switch S1 (or control panel ON pushbutton).
- 7) Verify control panel ON lamp and power supply controller board voltage sensing LEDs are lit. If lit, perform power supply adjustment procedures as detailed in step 9.

NOTE

If the LEDs are not lit or go out after a few seconds, a multioutput power supply or power supply controller board problem exists. Voltage adjustments can not be performed until problem is corrected. Perform procedures in step 8 to verify multioutput power supply is operational.

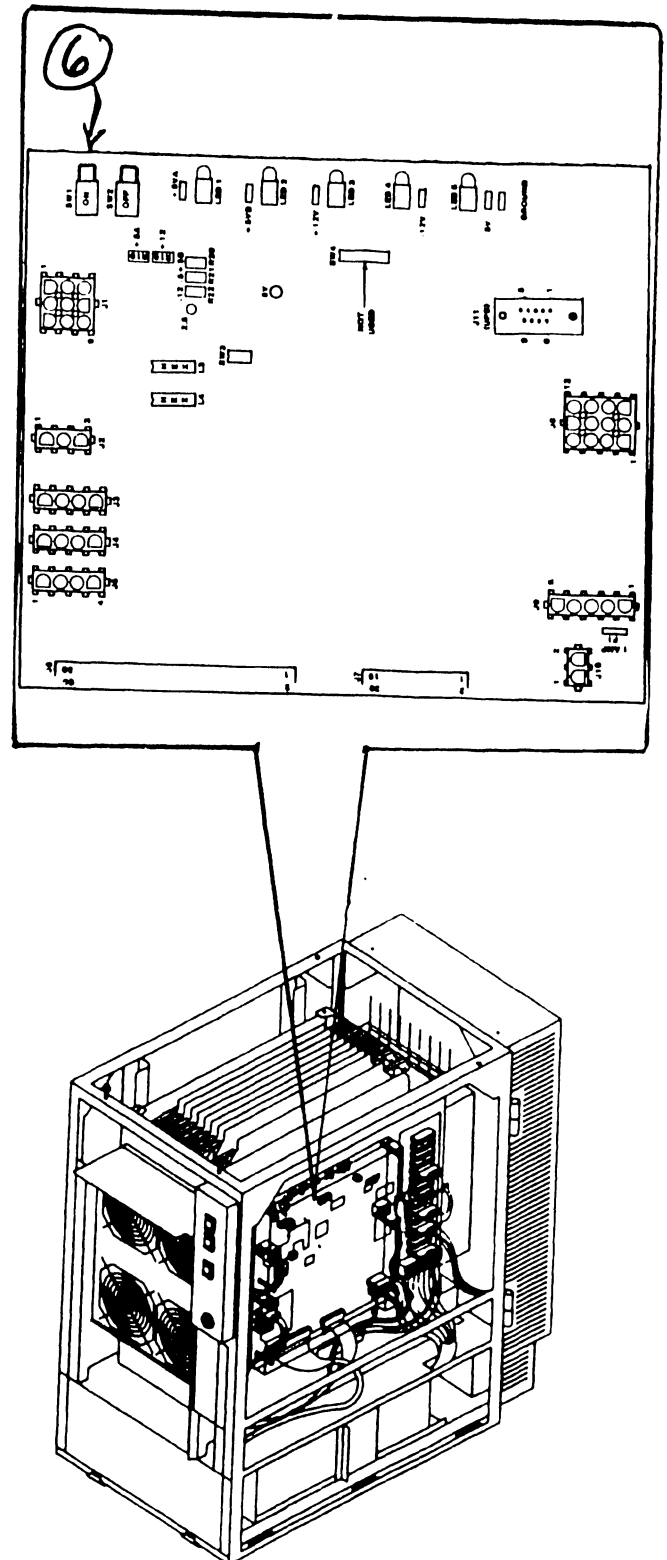

8.2 Electrical Adjustments

8.2.1 Multioutput Power Supply Voltage Adjustments (sheet 2 of 4)

- 8) To verify multioutput power supply perform the following:
- a) Remove 4-pin power control cable plug from power supply controller board connector J3.

WARNING

Inserting power supply test plug into power control cable (step b) will immediately turn on the multioutput power supply if the ac On/Off circuit breaker is in the ON position.

- b) Insert power supply test plug into P3 of the power supply control cable.
- c) If the power supply comes up and stays up, the power supply is good. A problem exists on the power supply controller board. (-6.x.x)
- d) If the power supply does not come up, the power supply is defective and must be replaced. (-7.2.24)

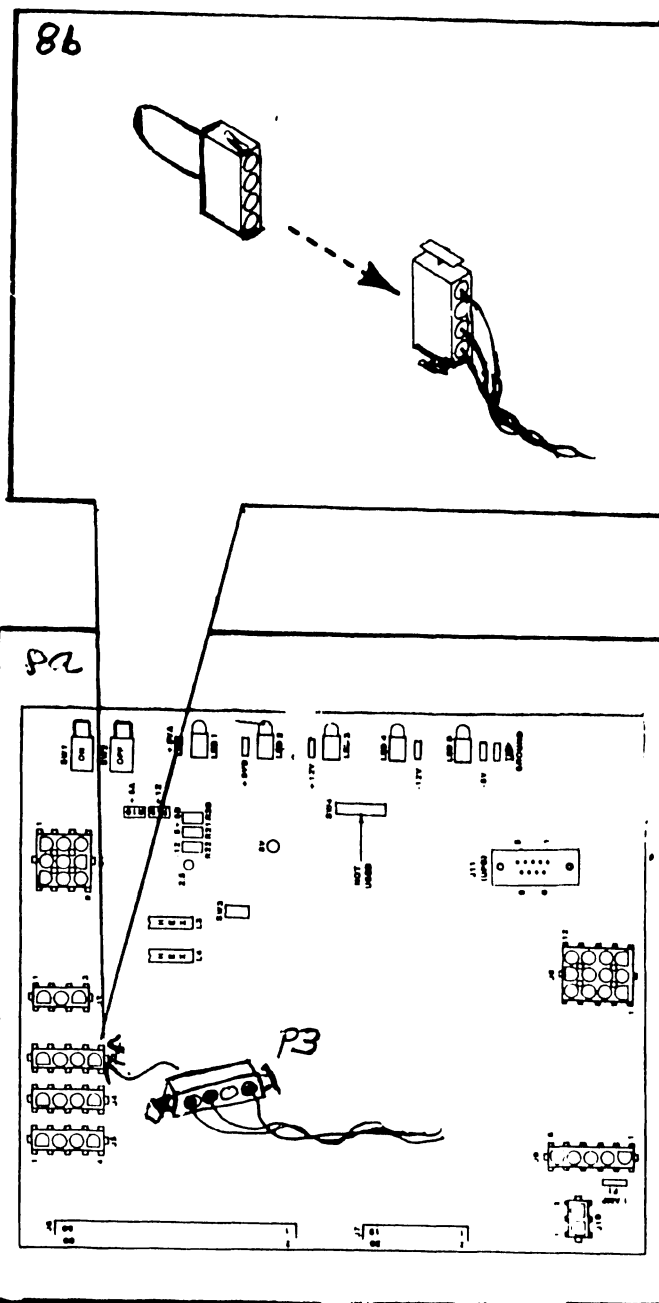
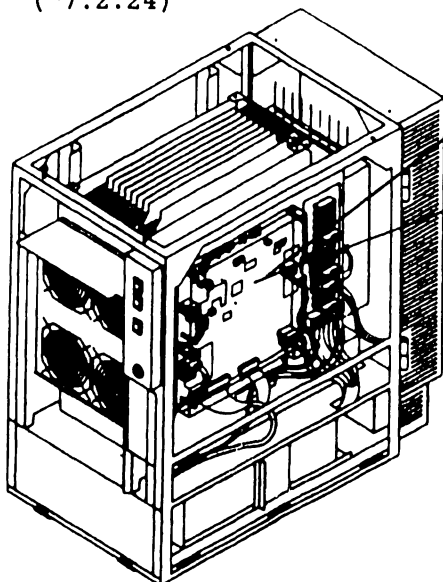

8.2 Electrical Adjustments

8.2.1 Multioutput Power Supply Voltage Adjustments (sheet 3 of 4)

- 9) Locate power supply controller board test points.
- 10) Connect common lead of DVM to TP ±0V (Ground).

NOTE

Voltage +5VB is not used by the system. LED2 should light indicating voltage is present at TP+5VB but voltage level should be disregarded.

- 11) Connect DVM lead to power supply controller board test points (TP+5VA, TP+12V, TP-5V, and TP-12V) to verify dc voltage limits.

TP	Voltage	Limits (VDC)
TP+5VA	+5.0A	+4.96V to +5.04V
TP+12V	+12.0	+11.96V to +12.04V
TP-5V	-5.0	-4.96V to -5.04V
TP-12V	-12.0	-11.96V to -12.04V

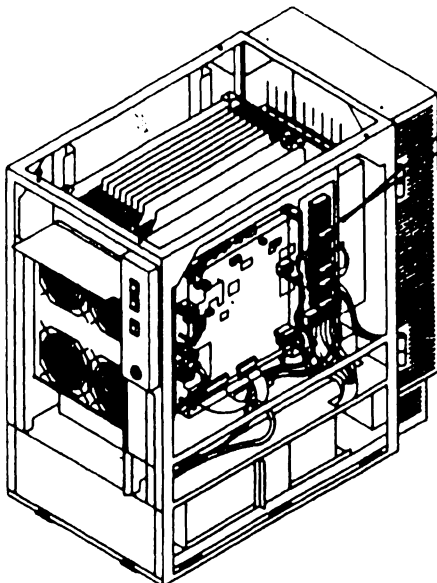
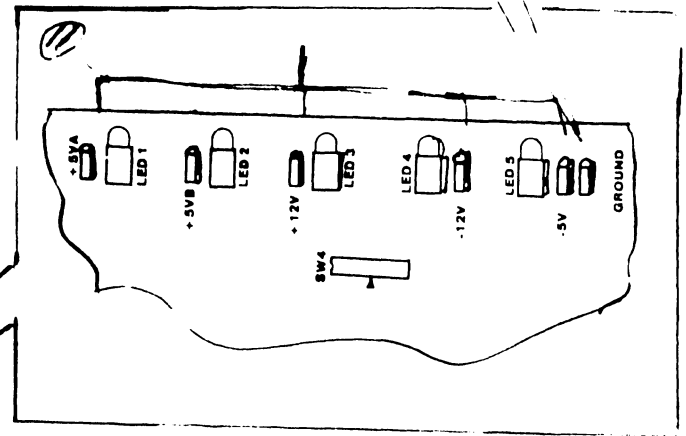
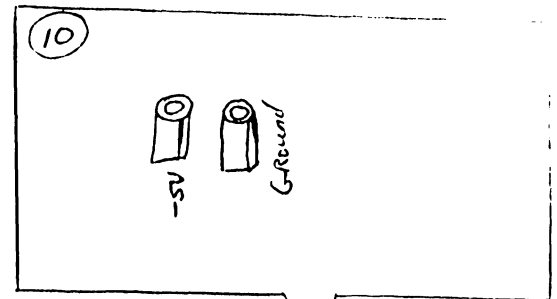

8.2 Electrical Adjustments

8.2.1 Multioutput Power Supply Voltage Adjustments (sheet 4 of 4)

NOTE

Adjust +5.0A voltage (V1) more towards the maximum voltage limit (+5.04V).

- 12) Adjust V1 (+5VA) to acceptable voltage level.
- 13) Adjust V2 (+12V) to acceptable voltage level.
- 14) Adjust V3 (-5V) to acceptable voltage level.
- 15) Adjust V4 (-12V) to acceptable voltage level.

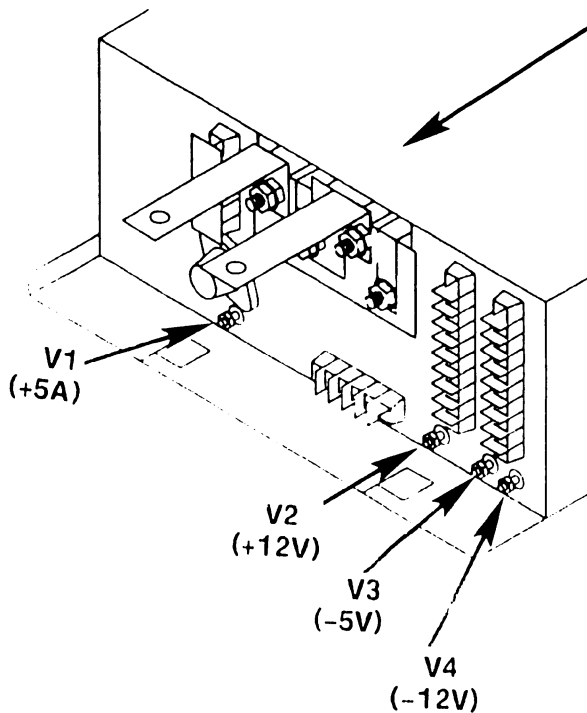
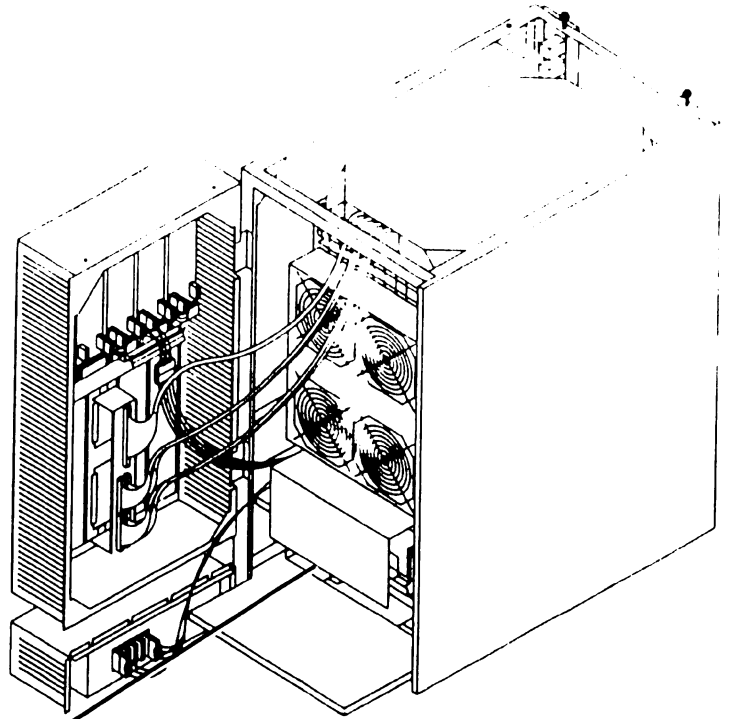

8.2 Electrical Adjustments

8.2.2 Power Supply Controller Adjustments (sheet 1 of 9)

1) Verify power supply controller board calibration voltages are present on power supply controller board.

a) Connect common lead of DVM to TP $\pm 0V$ (Ground).

b) Connect DVM lead to power supply controller board test points (TP8 - 8 volts, TP2 - 2.5 volts) to verify calibration voltages.

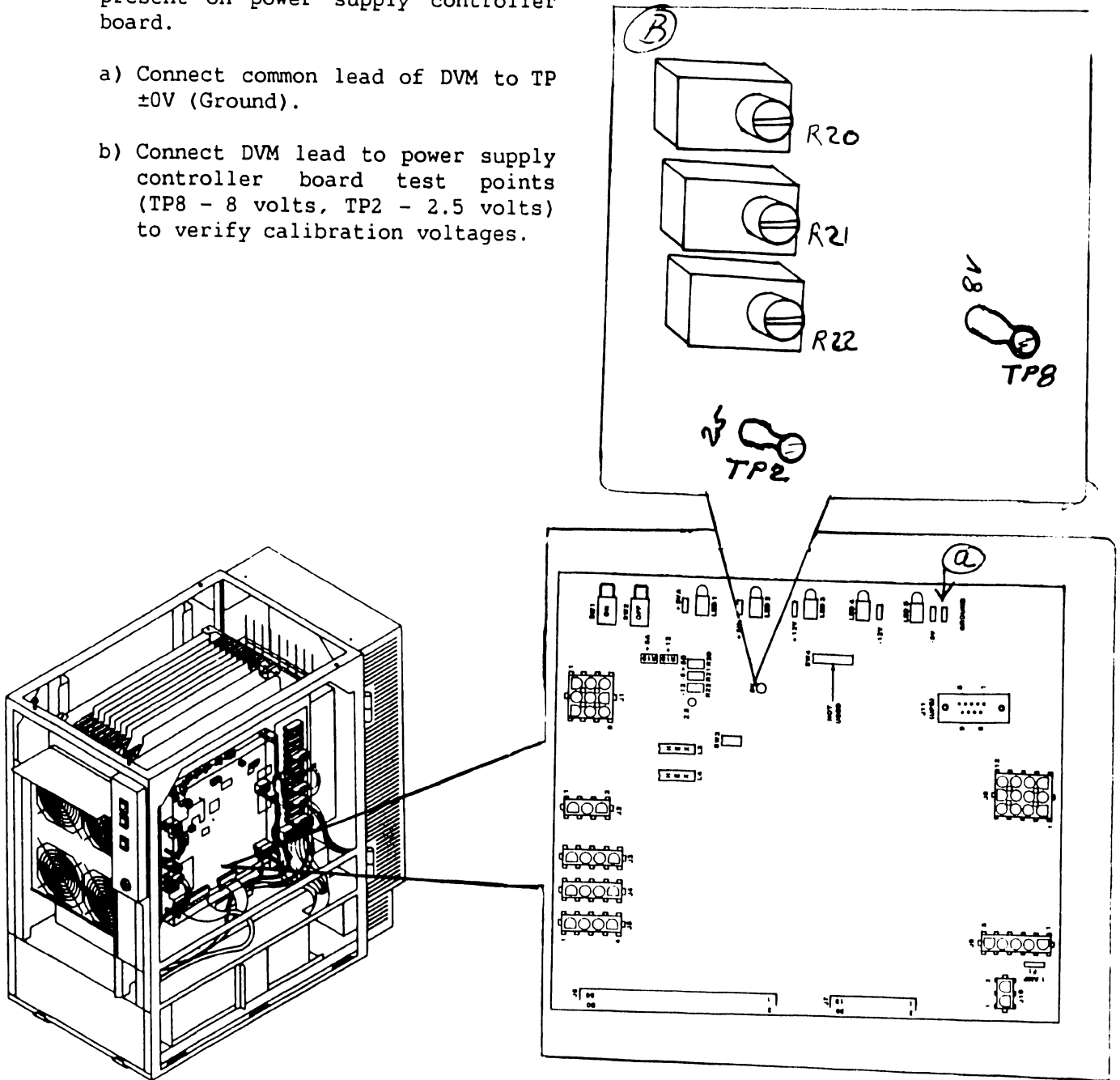

8.2 Electrical Adjustments

8.2.2 Power Supply Controller Adjustments (sheet 2 of 9)

+5.0AV Calibration

- 2) Set 4-bit Voltage address switch SW3 to +5.0AV A/D calibration address.
- 3) While viewing the two hex displays (L4 high digit and L3 low digit), Adjust R19 to hex display values:

Minimum	Hex Value		Maximum
	Exact		
7 E	8 0	8 2	

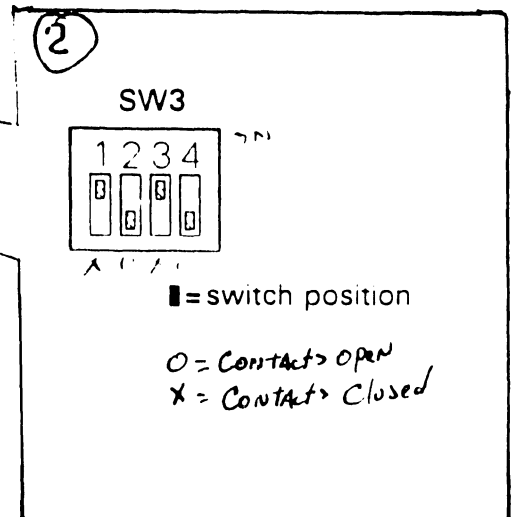
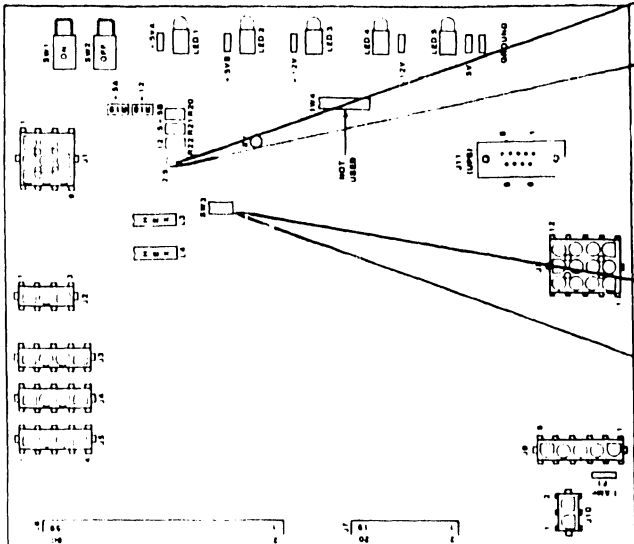
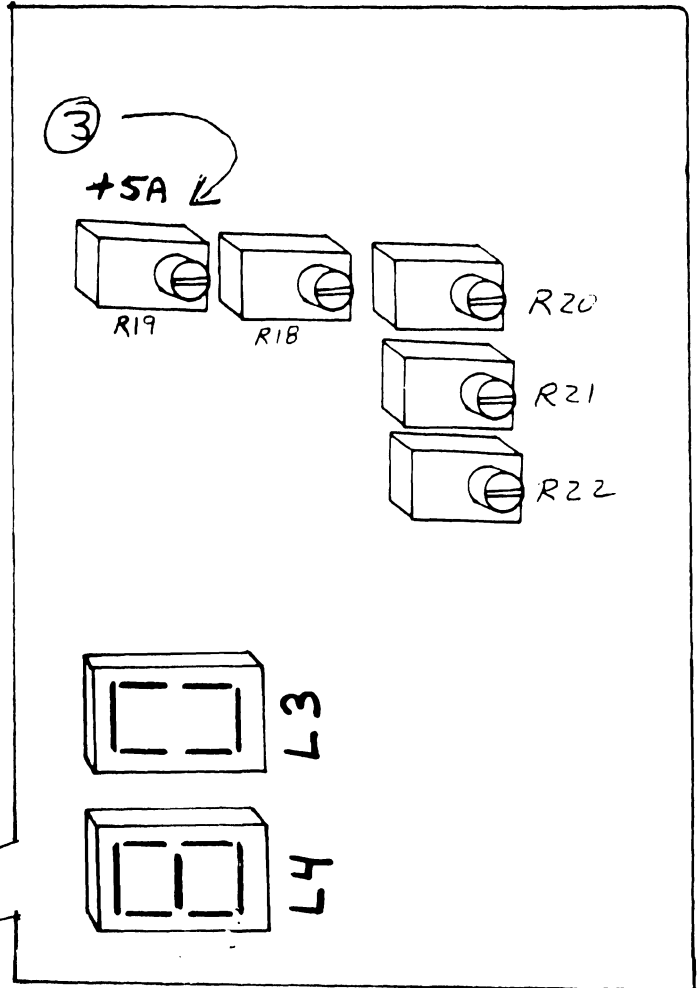

8.2 Electrical Adjustments

8.2.2 Power Supply Controller Adjustments (sheet 3 of 9)

+12.0V Calibration

- 4) Set 4-bit Voltage address switch SW3 to +12.0V A/D calibration address.
- 5) While viewing the two hex displays (L4 high digit and L3 low digit), Adjust R18 to hex display values:

Minimum	Hex Value		Maximum
	Exact		
7 E	8 0	8 2	

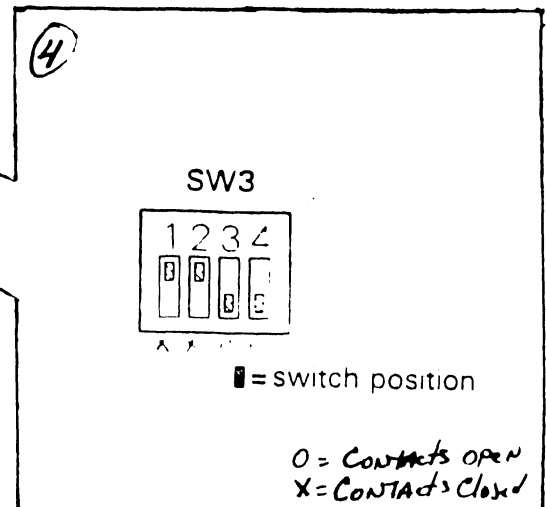
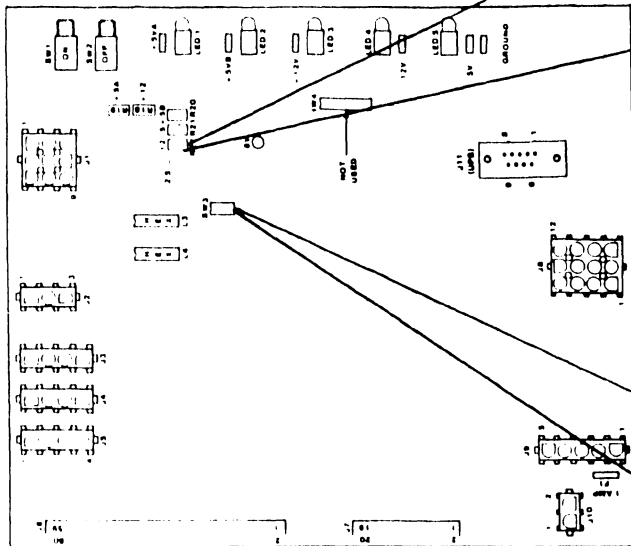
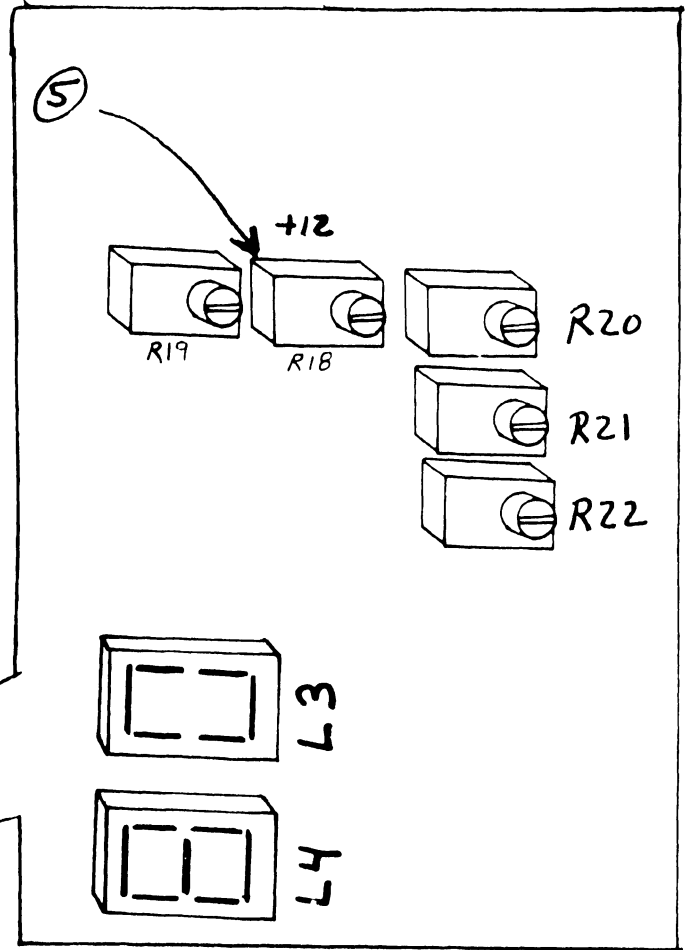

8.2 Electrical Adjustments

8.2.2 Power Supply Controller Adjustments (sheet 4 of 9)

-12.0V Calibration

- 6) Set 4-bit Voltage address switch SW3 to -12.0V A/D calibration address.
- 7) While viewing the two hex displays (L4 high digit and L3 low digit), Adjust R22 to hex display values:

Minimum	Hex Value		Maximum
	Exact		
7 E	8 0	8 2	

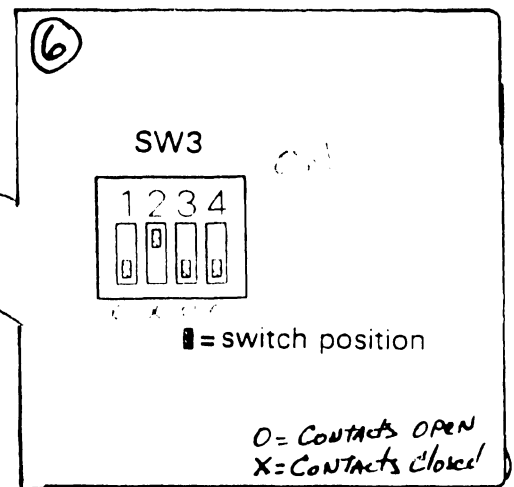
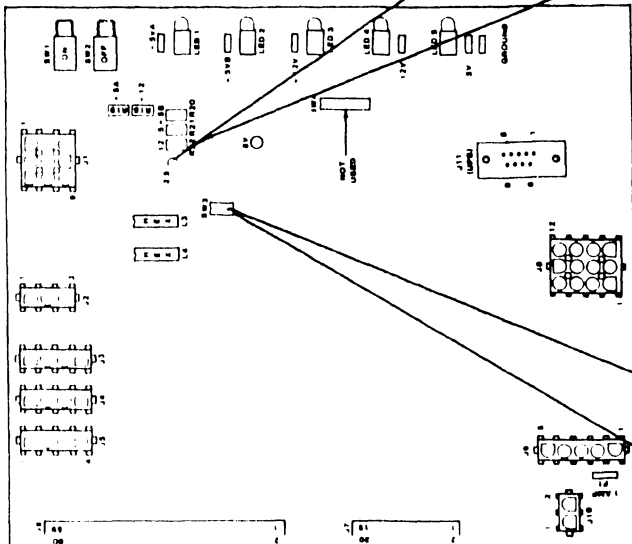
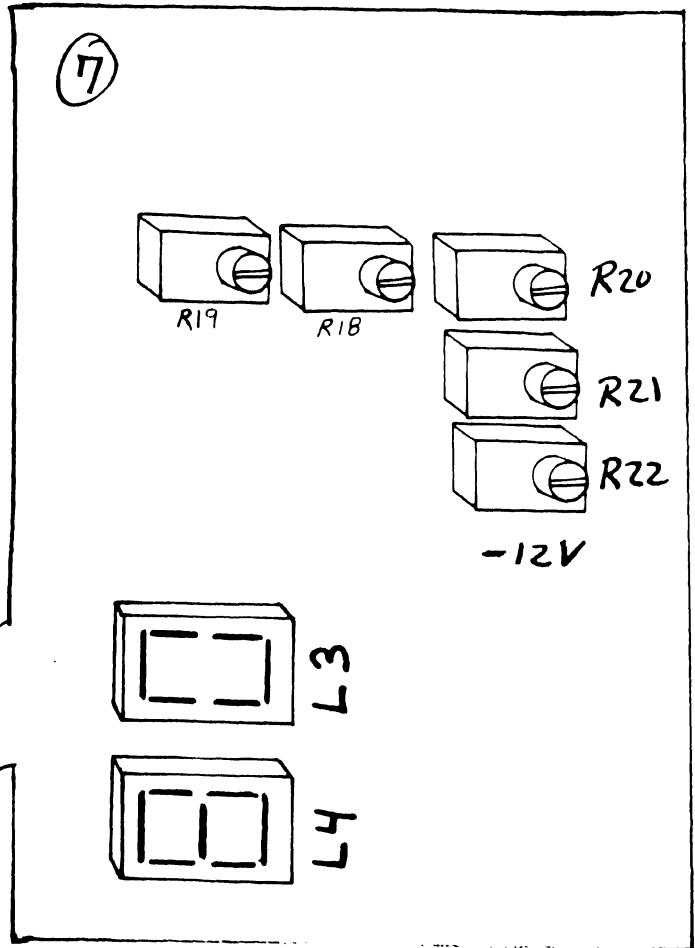

8.2 Electrical Adjustments

8.2.2 Power Supply Controller Adjustments (sheet 5 of 9)

-5.0V Calibration

- 8) Set 4-bit Voltage address switch SW3 to -5.0V A/D calibration address.
- 9) While viewing the two hex displays (L4 high digit and L3 low digit), Adjust R21 to hex display values:

Minimum	Hex Value		Maximum
	Exact		
7 E	8 0	8 2	

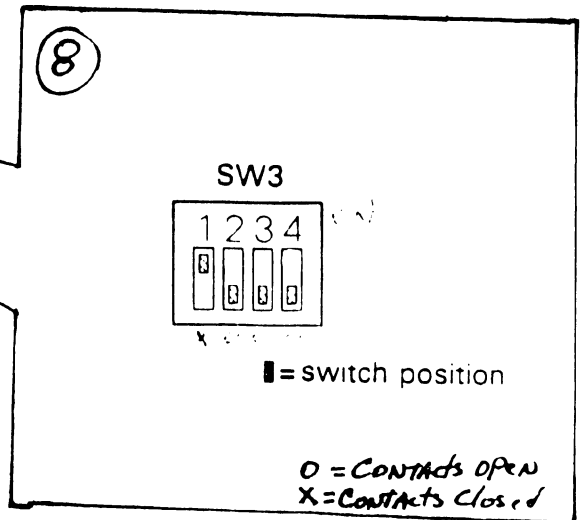
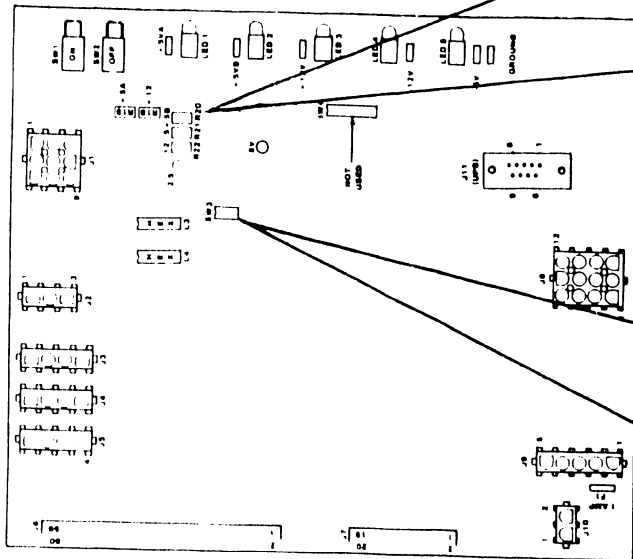
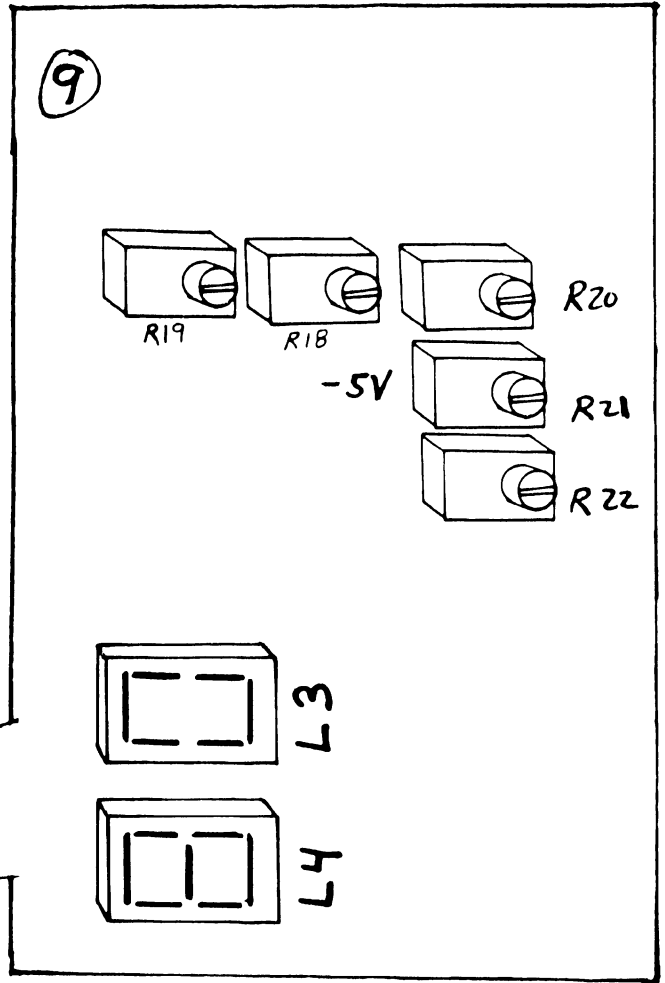

8.2 Electrical Adjustments

8.2.2 Power Supply Controller Adjustments (sheet 6 of 9)

- 10) Using the the system console, go to the System Console Menu screen. (~6.x.x)
 - 11) Ensure the key switch is in 'Remote Service' position. (~6.x.x)
 - 12) Enter the password 'CSG + current time' (four digits displayed on the System Console screen).
-

NOTE

While entering the password, the keyboard beeper will sound as each key is pressed. This is normal and is intended to discourage unauthorized personnel from enabling the full System Console Menu.

- 13) The system console is now in 'service mode' and the System Console Menu will be displayed.

*** Wang VS System Console ***

SYSCON Version X.X.X

2:44 PM

Monday January 5, 1987

Press (HELP) for online system console information.

Use the function keys to select a command:

- | | |
|---------------------------------|-----------------------------|
| (1) ENTER Workstation Emulation | (8) IPL System |
| (2) ENTER Control Mode | (9) RESET Console |
| (3) ENTER Service Log Mode | (10) Terminate Service Mode |
| (4) ENTER Offline Diagnostics | (11) SHOW Error Log |
| (5) AUTO IPL | (12) SET Console Defaults |
| (6) RSAF Functions | (13) SET Time and Date |
| (29) Install Software | (32) Wang PC Emulation |
-

8.2 Electrical Adjustments

8.2.2 Power Supply Controller Adjustments (sheet 7 of 9)

- 14) Press PF4 to enter Offline Diagnostics. The Diagnostics Disclaimer screen appears. (-6.x.x)
Press 'EXECUTE' to display the DCS Diagnostic Selection Menu.

Wang VS Diagnostic Control System hh/mm
Rev XXXX (c) Copr. Wang Laboratories, Inc. 1986

01 PCI Test

- SCUI Test
- CP8 Static Test
- CP8 Self Test
- AGU, ESU Test
- ATU Test
- SCU / Memory Test
- CPU / Memory Test
- SBI Test
- I/O BIT Monitor
- CPU Unit Test
- FPU Test

- SuperBal
- VS Environment

SPACE - item position
INSERT - select
DELETE - deselect
SHIFT+INSERT - hex #
EXEC - proceed

HELP is available

8.2 Electrical Adjustments

8.2.2 Power Supply Controller Adjustments (sheet 8 of 9)

- 15) Position cursor next to 'VS Environment'. Press 'INSERT' to select diagnostic.
- 16) Press 'EXECUTE' to run the diagnostic. The Environment Test Screen will be displayed.

NOTE

The Environment Test Screen is only a monitor for the voltages on the power supply controller board. Do not adjust voltages and/or A/D outputs using this screen.

```

Wang VS Diagnostic Control System                09:15:32
Rev xxxx      (c) Copr. Wang Laboratories, Inc. 1986
               □□□□ ■□□□ □□□□ □□□□

Sequence: 1                                     Error Cnt: 0
Diagnostic: R16C4 Large VS Environment
Test: Display

|-----|
| DCS Status: Diagnostic Executing |
|-----|

Voltage Readings = +5.000   +5.000   -5.000   +12.00   -12.00

SCU Control Registers = 4700  78FF      SCU Status Registers = 86C0  1000

CPU SCR = 0800          MCU SCR = 0800      MCU ELog = 8063 E007 0707

SBIO SCR = 0048        SBI Status = 0000   SBIO ELog = 0000 00B8 0023

Front Panel key switch is set to REMOTE DIAGNOSTIC

PSI Register = EF11      System reset pressed      AC power cycled

```

8.2 Electrical Adjustments

8.2.2 Power Supply Controller Adjustments (sheet 9 of 9)

17) Read the voltages displayed on the Environment Screen. From left to right, voltage readings represented are:

+5VA, +5VB, -5V, +12V, -12V

18) Power-down mainframe. (-4.2)

19) Replace AC PDU.

20) Replace system covers.

SECTION

9

UNPACKING

AND

SETUP

SECTION 9 CONTENTS

SECTION 9 UNPACKING AND SETUP

	<u>Page</u>
9.1	Installation Site Check 9-1
9.2	Tools And Equipment 9-2
9.3	Unpacking Procedures 9-3
9.3.1	Unpacking And Inspecting VS-7010 Computer System 9-3
9.3.2	Unpacking And Inspecting SCU Professional Computer 9-5
9.3.3	Unpacking And Inspecting SCU (PM-004L) Moniotr 9-6
9.3.4	Unpacking And Inspecting SCU (720) Keyboard 9-7
9.3.5	Unpacking Peripherals 9-8
9.3.6	Claims Information 9-9
9.3.7	Initial Set-Up 9-10
9.4	Inspection 9-11
9.4.1	VS-7010 Mainframe Inspection 9-11
9.4.2	Peripheral Inspection 9-13
9.4.3	VS-7010 Power Service Requirements (Domestic) 9-14

9.1 Installation Site Check

Proper equipment location and site preparation are important for reliable operation of the VS-7010 Computer System. The Customer Engineer is responsible for installation of all models of the VS-7010 Computer System and peripherals. The following conditions must be met:

- All site plans should have been approved by both the customer and a Customer Service Representative.
- All building alterations must have been completed and inspected.
- All electrical wiring, air conditioning, and telecommunications (TC) modifications must have been installed and tested. (The following TC equipment should have been ordered for remote maintenance support, if option is elected:)
 - a. Telephone line. (Dedicated line is not required.)
 - b. Telephone.

NOTE

RF11W flush mount wall phone jack can be used with the "T" connector and a desk top phone, but a wall mounted phone cannot be used.

- c. One of the following modular connecting blocks for the telephone:
 - 1. RJ11C for desk top telephone.
 - 2. RF11W for flush mount wall telephone.

Pre-installation inspection is to be performed two weeks prior to delivery of equipment. At this time, the service representative will check the site for compliance with VS site specifications. The service representative will bring any unsatisfactory conditions noted to the attention of the customer for correction.

9.2 Tools and Equipment

- Standard CE tool kit WLI# 726-9401.
- Digital Multimeter.

9.3 Unpacking Procedures

9.3.1 Unpacking and Inspecting VS-7010 Computer System (Sheet 1 of 2)

WARNING

The VS-7010 Computer System weighs approximately 220 pounds (100. Kg). Be sure adequate help is available to perform any cabinet movement required.

- 1) Check packing slips to make sure the proper equipment has been delivered. Refer to model number information in the following table. After checking packing slips, inspect shipping containers for damage. If damage is noted, notify your manager.

VS-7010 Models

Model Number	WLI/P/N	Description
VS-7010-4	157/177-7537	VS-7010, 4MB main memory

NOTES

Part number prefix 157 = 50Hz ac line frequency mainframes.

Part number prefix 177 = 60Hz ac line frequency mainframes.

VS-7010 Upgrades

Model Number	WLI/P/N	Description
7MEM4	289-1291	4MB Memory Upgrade
7MEM8	289-1292	8MB Memory Upgrade
7MEM16	289-	16MB Memory Upgrade
7MEM32	289-	32MB Memory Upgrade

9.3 Unpacking Procedures

9.3.1 Unpacking and Inspecting VS-7010 Computer System (Sheet 2 of 2)

- 2) Remove shipping carton from VS-7010 computer.
- 3) Roll (and slide) VS-7010 computer off the pallet.
- 4) Visually inspect unit for external damage.

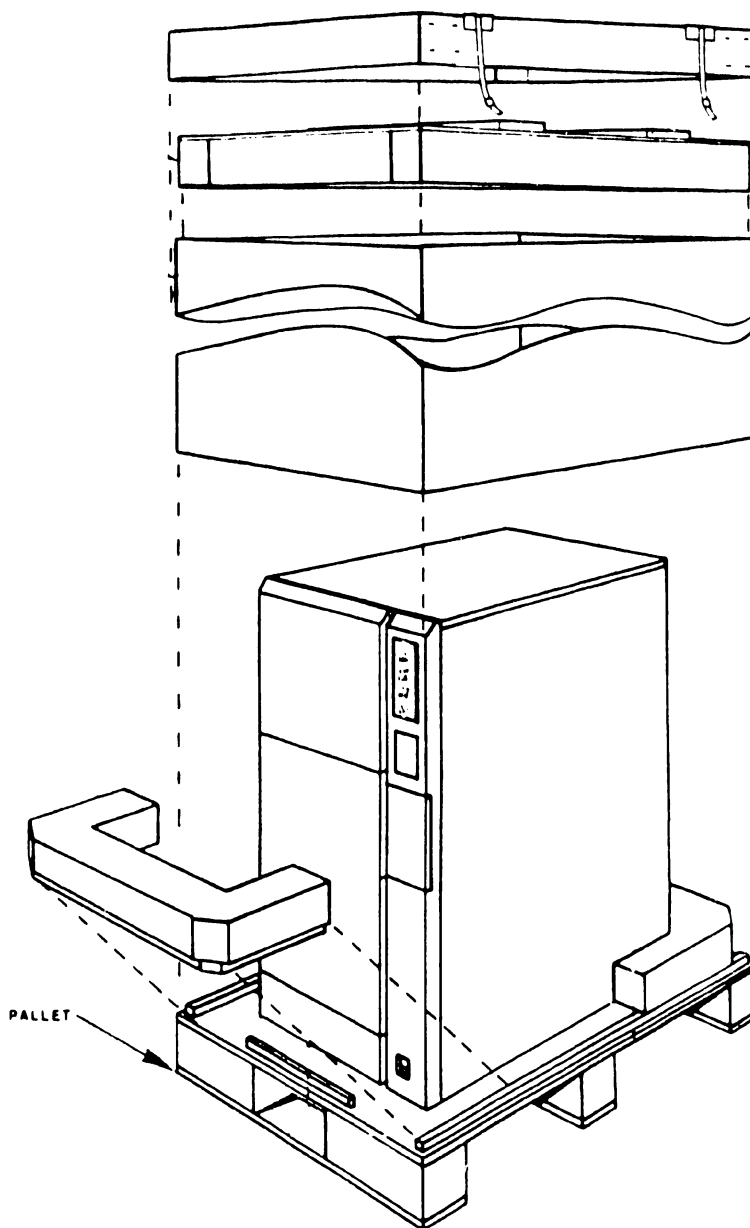

9.3 Unpacking Procedures

9.3.2 Unpacking and Inspecting SCU Professional Computer

- 1) Remove Professional Computer from shipping carton.
- 2) Visually inspect unit for external damage.

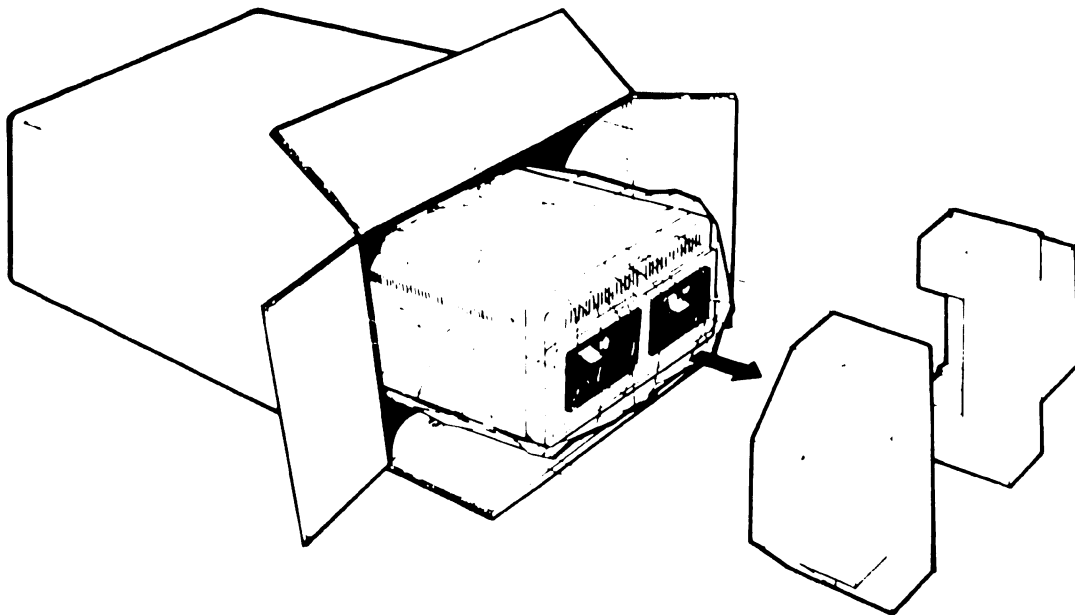

9.3 Unpacking Procedures

9.3.3 Unpacking and Inspecting SCU (PM-004L) Monitor

- 1) Remove monitor from shipping carton.
- 2) Visually inspect unit for external damage.

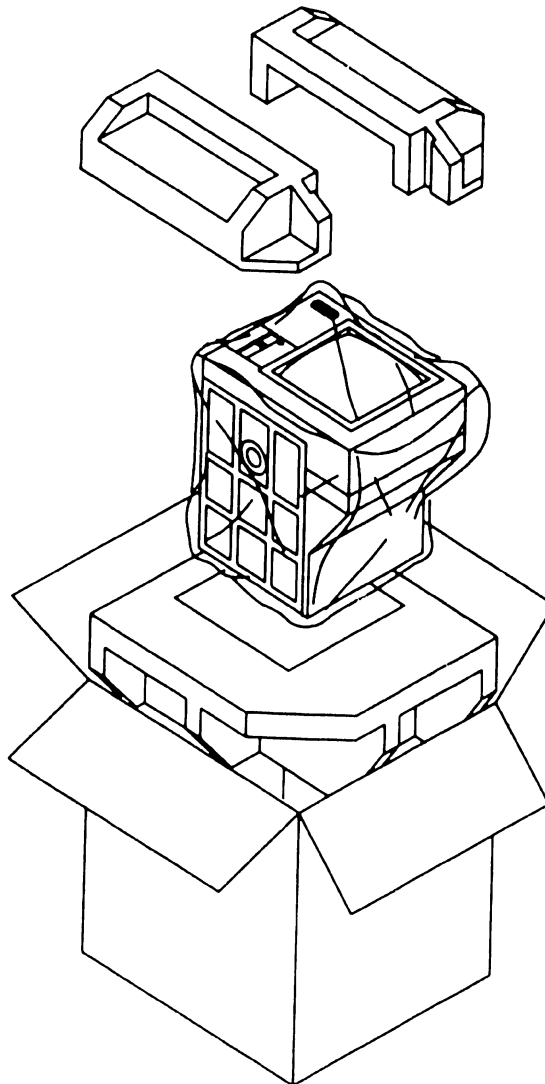

9.3 Unpacking Procedures

9.3.4 Unpacking and Inspecting SCU (720) Keyboard

- 1) Remove keyboard from shipping carton.
- 2) Visually inspect unit for external damage.

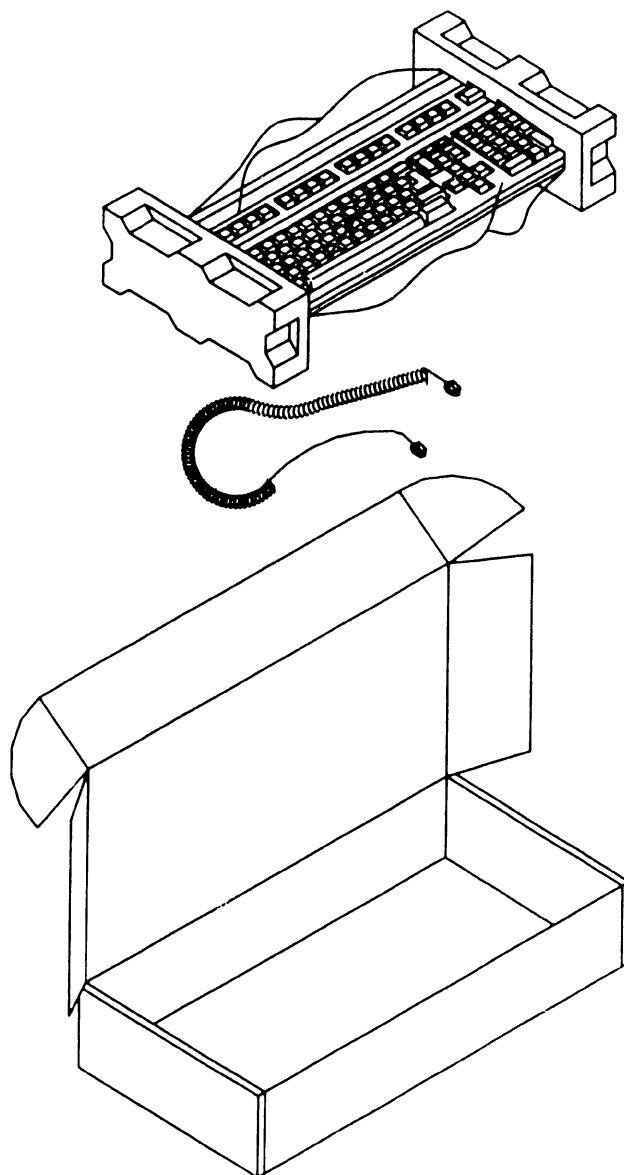

9.3 Unpacking Procedures

9.3.5 Unpacking and Inspecting Peripherals

- 1) Unpack all peripherals according to the procedures outlined in the applicable maintenance manuals. As each unit is unpacked, check it for any obvious shipping damage. If damage is noted, notify your manager.

9.3 Unpacking Procedures

9.3.6 Claims Information

If damage is discovered during unpacking or inspection, notify your service manager.

9.3 Unpacking Procedures

9.3.7 Initial Set-Up

- 1) Move the cabinet to its permanent location.
- 2) Once cabinet is in place, check service clearances to be at least:

Service Clearance	Inches	Centimeters
Front	36	91.4
Rear	36	91.4
Left	24	60.9
Right	36	91.4
Top	36	91.4

CAUTION

THIS COMPUTER EQUIPMENT HAS BEEN VERIFIED AS FCC CLASS A. IN ORDER TO MAINTAIN COMPLIANCE WITH FCC CLASS A VERIFICATION, THE FOLLOWING CONDITIONS MUST BE ADHERED TO DURING NORMAL OPERATION OF EQUIPMENT.

- ALL COVERS MUST BE ON THE SYSTEM AND SECURED IN THE PROPER MANNER.
 - ALL INTERNAL CABLES MUST BE ROUTED IN THE ORIGINAL MANNER WITHIN THE CABLE CLAMPS PROVIDED FOR THAT PURPOSE.
 - ALL EXTERNAL CABLES MUST BE SECURED AND THE PROPER CABLE USED TO ENSURE THAT CABLE SHIELDING IS PROPERLY GROUNDED TO THE CABLE CLAMPS PROVIDED.
 - ALL HARDWARE IS PROPERLY SECURED.
-

9.4 Inspection**9.4.1 VS-7010 Mainframe Inspection (Sheet 1 of 2)****NOTE**

Quality assurance procedures and tests have shown that VS mainframes arriving on customer's premises require only visual inspection, voltage checks, software loading, and cabling. Therefore, the following inspection and installation procedures for all VS mainframe products are in effect.

DO NOT REMOVE PRINTED CIRCUIT BOARD FOR INSPECTION

DO NOT CLEAN PRINTED CIRCUIT BOARD CONTACTS WITH AN ERASER

INSPECT CPU MAINFRAME VISUALLY

**REPORT INSTALLATION PROBLEMS ON THE INSTALLATION
REPORT AND STATE SPECIFIC CAUSES OF FAILURE**

- 1) Remove top cover. (→ 7.2.1)
- 2) Remove front cover (→ 7.2.2) and side covers. (→ 7.2.3)
- 3) Remove card cage cover. (→ 7.2.4)
- 4) Inspect the interior of mainframe for packing material and shipping damage such as broken connectors and loose fastening hardware.

9.4 Inspection**9.4.1 VS-7010 Mainframe Inspection (Sheet 2 of 2)**

- 5) Refer to the shipping list to make sure that the correct circuit boards have been shipped.
- 6) Make sure all circuit boards are properly seated in the backplane.
- 7) Inspect the power supply for damage and loose connections. At this time make sure all power supply connections are tight.
- 8) If necessary, vacuum clean the unit. (- 5.4)
- 9) Do not reassemble the mainframe at this time.
- 10) If damage is discovered at any time during the inspection, follow the reporting procedure (-9.3.6).

9.4 Inspection

9.4.2 Peripheral Inspection

Inspect each peripheral according to procedures outlined in the applicable maintenance manuals. If damage is discovered at any time during the peripheral inspection, follow the reporting procedure (~9.3.6).

9.4 Inspection

9.4.3 VS-7010 Power Service Requirements (Domestic) (Sheet 1 of 2)

Inspection and electrical checks are required to make sure the power source and receptacle meet all specified requirements before proceeding with the mainframe and peripheral installation.

NOTE

The following procedures are for domestic 208/240 Vac, 60 Hz installations. Installations outside the continental USA, requiring other configurations and voltages, must be dealt with on a site by site basis.

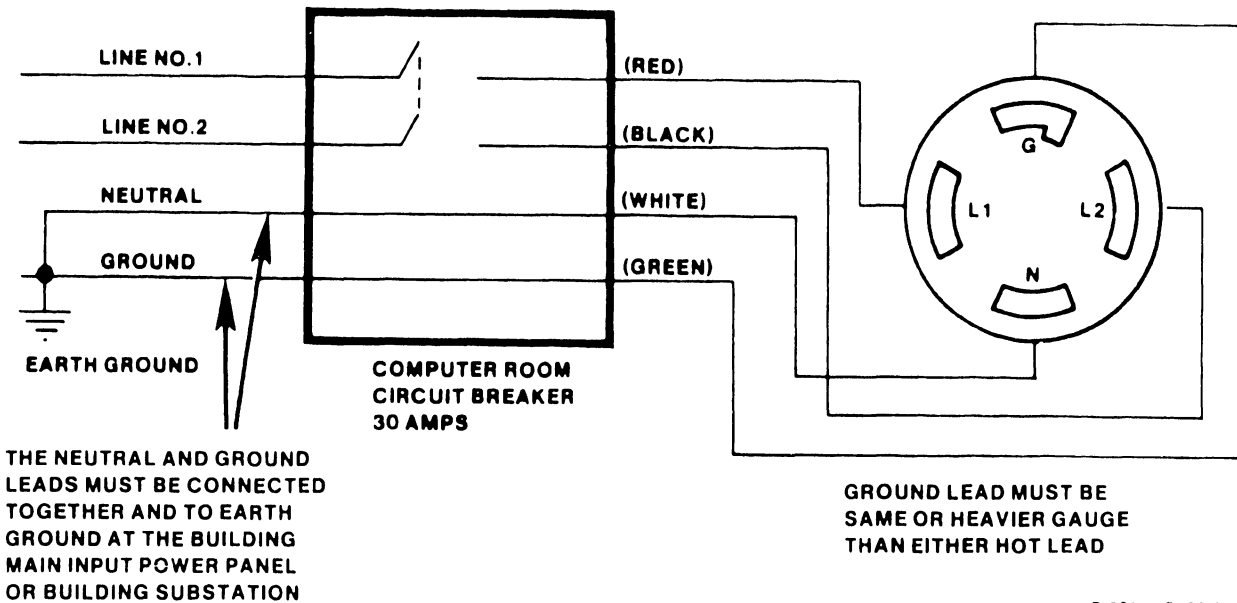

B-03141-FY86-2

	Receptacle Body	Matching Connector
NFMA Configuration	L14-30IGR	L14-30P
Hubbel Part Number	IG2710	2711

741-1721-A

9.4 Inspection

9.4.3 VS-7010 Power Service Requirements (Domestic) (Sheet 2 of 2)

CAUTION

Failure to verify input power service can result in serious damage to the mainframe circuits and to connected peripherals.

- 1) Using a digital voltmeter, perform ac receptacle input voltage checks as outlined in the following table:

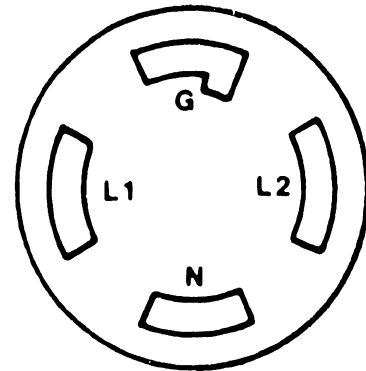

*NEMA 14-30IGR
(Hubbel IG-2710)*

Test Points	Voltage Measurements
AC Hot (L1) to Ground (G)	120 Vac ($\pm 10\%$)
AC Hot (L2) to Ground (G)	120 Vac ($\pm 10\%$)
AC Hot (L1) to AC Hot (L2)	208/240 Vac ($\pm 10\%$)

SECTION

10

**FUNCTIONAL
DESCRIPTION**

SECTION 10
FUNCTIONAL DESCRIPTION

This section is not included in the Preliminary
VS-7010 Computer System manual.

SECTION

11

SPECIFICATIONS

SECTION 11
SPECIFICATIONS

	<u>Page</u>
11.1 HARDWARE	11-1
11.1.1 VS-7010 Mainframe	11-1
11.1.2 VS-7010 Architecture	11-2
11.1.3 Multioutput Power Supply Specifications	11-3
11.2 OPERATING SYSTEM SOFTWARE	11-4
11.3 DIAGNOSTICS	11-5
11.3.1 VS-7010 Built-In-Test (BIT) Programs	11-5
11.3.2 Diagnostic Tests	11-6

11.1 Hardware

11.1.1 VS-7010 Mainframe**Computer System Dimensions:**

Depth: 31.0 inches (78.74 cm)
Width: 15.3 inches (39.0 cm)
Height: 30.5 inches (77.5 cm)

Computer System Weight:

220 pounds (100 Kg) Maximum Configuration

Installation Requirements:

Front Clearance: 36 inches (91.4 cm)
Rear Clearance: 36 inches (91.4 cm)
Left Side Clearance: 24 inches (60.9 cm)
Right Side Clearance: 36 inches (91.4 cm)
Top Clearance: 36 inches (91.4 cm)
Position: Upright Only

Power Requirements:

Dedicated circuit, 30 Amps Breaker
208 - 240 Vac (208 Vac nominal)
60 Hz \pm 0.5 (60 Hz nominal) (Domestic)
50 Hz \pm 0.5 (50 Hz nominal) (International)
Start-Up - 12.0 Amps RMS @ 208 Vac (2496 volt-amps)

NEMA Receptacle L14-30IGR
NEMA Plug L14-30P
Hubbel Receptacle IG2710
Hubbel Plug 2711

Environmental Requirements:

Relative Humidity:
20% - 80% non-condensing
Ambient Temperature:
60° - 90°F (15.5° - 32° C)
Max Temp Gradient:
12°F/Hr (4°C/Hr)
Max Wet Bulb Temp:
75°F (24°C)
Max Altitude:
10,000 Ft (3048 Km)
Heat Dissipation:
6304 BTU/Hr, (1554 KCal/Hr)

11.1 Hardware

11.1.2 VS-7010 Architecture**Memory Cycle Time:**

240 nSeconds Instruction Execution (Typical)
420 nSecond Memory Access (8-byte read)
540 nSecond Memory Access (16-byte read)
900 nSecond Memory Access (32-byte read)
120 nSecond Memory Access (8-byte write)

Memory Size:

4, 8, 16, or 32 MB
Cache Memory 32KB

Virtual Address Space/User 8MB
Virtual Address Space/Process 8MB

System Data Path:

CPU 32-bit
I/O 32-bit
Main Memory 64-bit
Word Length 32-bit

Bandwidth:

System Bus 66.6 MB/second
I/O Bus 33.3 MB/second

Number of Users:

96 Concurrent Serial Workstations
128 Concurrent Serial Workstations and Printers

Number of Processes

Concurrent 255
Background 63

Maximum Drives/Tapes:

Maximum Disk Storage 5.4 GB
12 Disk Drives @ 1.8 MB/second Data Rate

11.1 Hardware

11.1.3 Multioutput Power Supply Specifications**Output Voltages:****+5 Vdc:**

Adjustment Range: 4.96 to 5.04 Volts
Output Current: 275 Amps
AC Ripple: 35mV RMS (50mV Pk-Pk)

+12 Vdc:

Adjustment Range: 11.96 to 12.04 Volts
Output Current: 20 Amps
AC Ripple: 35mV RMS (50mV Pk-Pk)

-5 Vdc:

Adjustment Range: -4.96 to -5.04 Volts
Output Current: 10 Amps
AC Ripple: 35mV RMS (50mV Pk-Pk)

-12 Vdc:

Adjustment Range: -11.96 to -12.04 Volts
Output Current: 10 Amps (5 Amps)
AC Ripple: 35mV RMS (50mV Pk-Pk)

Power Dissipation:**Steady State:**

1850 Watts, 6304 BTU/Hr

11.2 Operating System Software

<u>Software</u>	<u>Version</u>	<u>Comments</u>	<u>WLI P/N</u>
Operating System	7.14		195-xxxx-x
VS-7010 SCU	1.05.02	Contains CP8 CPU ucode and DCS package	195-4682-9

11.3 Diagnostics**11.3.1 VS-7010 Built-In-Test (BIT) Programs**

<u>Diagnostic Name</u>	<u>PROM Rev.</u>	<u>Package P/N</u>	<u>PROM Location/Part Number</u>
928 Serial IOC	5684 1	295-4721-D	
SMD Disk IOC	56A4 2	295-4724-D	
Kennedy Tape IOC	5684 1	295-4730-D	
Telex Tape IOC	5684 1	295-4731-D	
Multiline TC IOC	5724	295-4729-DC	

NOTES

- 1) Complete 295 package part numbers include PROMS and documentation.

11.3 Diagnostics

11.3.2 Diagnostic Tests

<u>Diagnostic Name</u>	<u>Release</u>	<u>Package P/N</u>
Uniboot (Boot Loader)	846C	295-2479-3
FTU Off-Line	6385	295-2759-3
VOLCOPY	8181	702-0122-A
TCTESTER	6660	295-5181-5

NOTES

- 1) Complete 295 package part numbers include diskettes and documentation.
- 2) Diskette only part numbers (702 prefix) are shown if no package part numbers are available.

SECTION 12
ILLUSTRATED
PARTS

SECTION 12 CONTENTS

SECTION 12
ILLUSTRATED PARTS

		<u>Page</u>
12.1	MAJOR ASSEMBLIES	12-1
12.2	VS-7010 SUBASSEMBLIES	12-2
12.2.1	VS-7010 Computer System Covers	12-2
12.2.2	VS-7010 Computer Chassis	12-4
12.2.3	VS-7010 Computer Card Cage	12-6
12.2.4	VS-7010 Rear Panel Assembly	12-8
12.3	SUPPORT CONTROL UNIT (SCU) SUBASSEMBLIES	12-10
12.3.1	SCU Professional Computer	12-10
12.3.2	SCU Monitor	12-12
12.4	VS-7010 INTERCONNECTION DIAGRAM	12-14
12.5	CABLE ASSEMBLIES	12-16
12.5.1	Standard Cable Assemblies	12-16
12.5.2	Optional Cable Assemblies	12-17

12.1 Major Assemblies

Item	Part Number	Description
1	177-7537	VS-7010 Computer System, 4MB Main Memory
2	279-0659	SCU PM004L Monochrome Monitor
3*	725-3099-US	SCU Keyboard, Universal Low Profile
4	187-7536	SCU Professional Computer

* = Field Replaceable Item

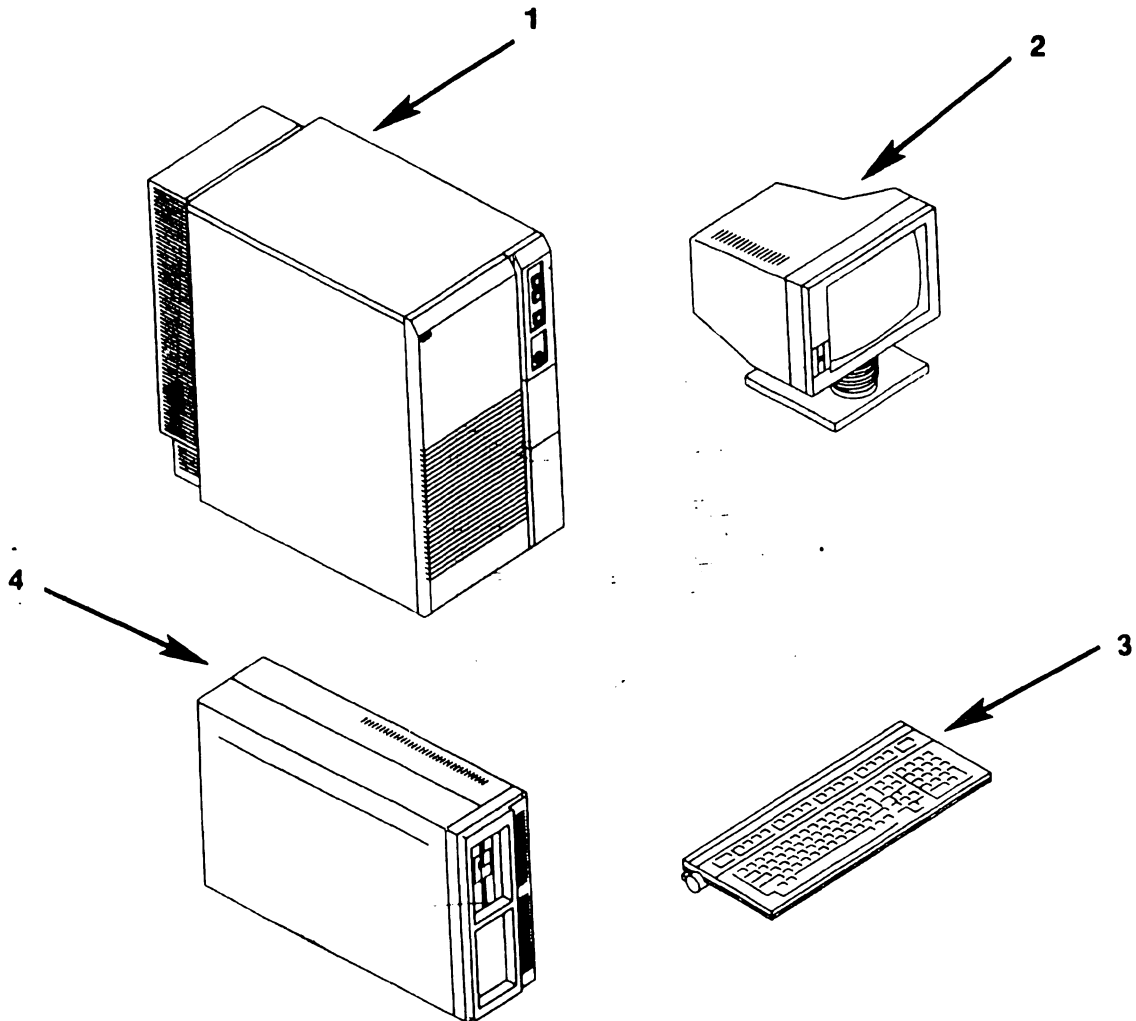

12.2 VS-7010 Subassemblies

12.2.1 VS-7010 Computer System Covers (Sheet 1 of 2)

Item	Part Number	Description
1	458-3971	Cover, Top
2	458-3293	Panel, Right Side
3	270-1104	Front Panel Assembly
4	458-3827	Frame Weldment
5	655-0061	Casters, Swivel
6	655-0060	Casters, Rigid
7	458-3294	Panel, Left Side
8*	660-1107	Air Filter, Foam

* = Field Replaceable Item

12.2 VS-7010 Subassemblies

12.2.1 VS-7010 Computer System Covers (Sheet 2 of 2)

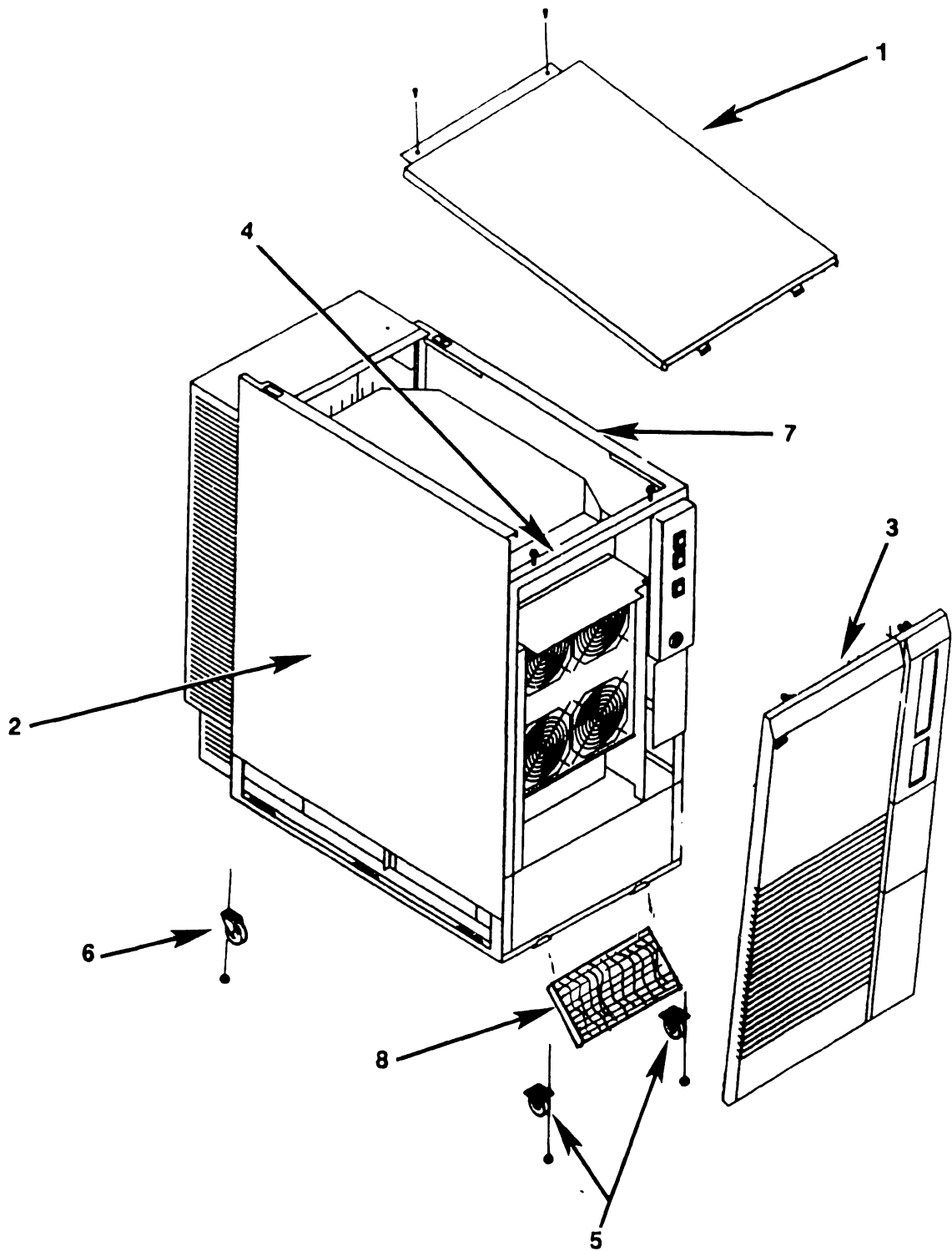

12.2 VS-7010 Subassemblies

12.2.2 VS-7010 Computer Chassis (Sheet 1 of 2)

Item	Part Number	Description
1*	270-1099	Control Panel Assembly
	220-3538	Cable, Control Panel; 26-position Soc
	325-1037	Keylock, Rotary 4-position
	325-2261	Pushbutton Switch; 12V Lamp, Red Lens
	325-2262	Pushbutton Switch; 12V Lamp, Green Lens
	325-2264	Pushbutton Switch; 12V Lamp, Yellow Lens
	* 370-0088	Lamp, 12V, Pushbutton Switch
2	452-4749	Shield, Power Supply Controller
3	458-3636	Guide, Cable
4*	210-8816	DC Power Distribution Unit (DC PDU)
5*	270-1100	Multioutput Power Supply Assembly
	725-3308-1	Multioutput Power Supply
	* 270-3450	DC Power Harness
	* 220-2643	Cable, Control Board Multiple Output
	* 220-2296	Cable, AC PDU to Power Supply
	458-1991	Bus Bar, Lower Positive
	458-1992	Bus Bar, Lower Ground
	451-5593	Bracket, Power Supply Mounting
6*	210-8809	Power Supply Controller Board
7	458-3831	Panel, Bottom Dress, PS Access
8*	270-1103	Backplane Assembly
	210-9847	Motherboard
	458-1989	Bus Bar, Upper Ground
	458-1990	Bus Bar, Upper Positive

* = Field Replaceable Item

12.2 VS-7010 Subassemblies

12.2.2 VS-7010 Computer Chassis (Sheet 2 of 2)

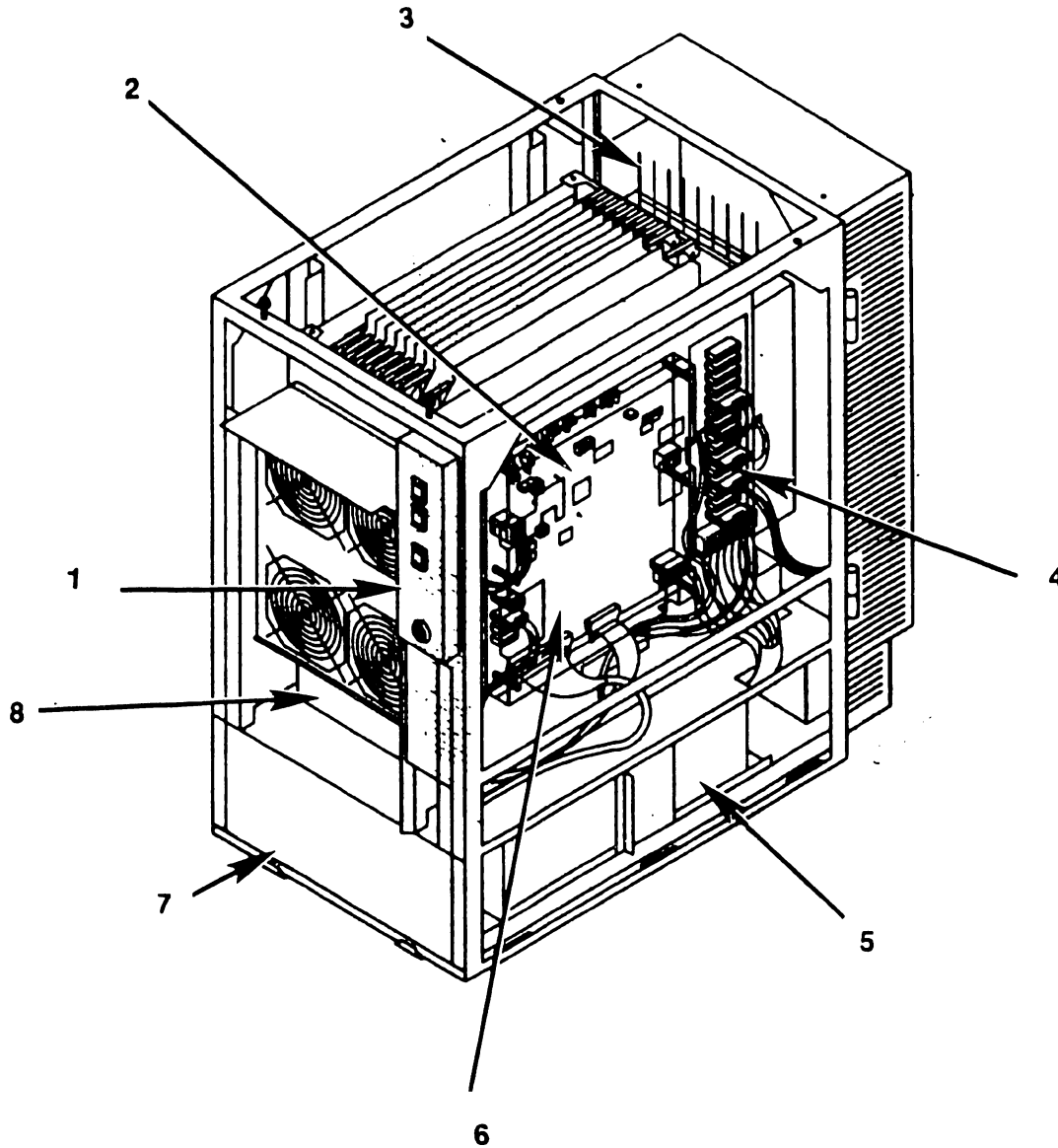

12.2 VS-7010 Subassemblies

12.2.3 VS-7010 Computer Card Cage (Sheet 1 of 2)

Item	Part Number	Description
1*	210-9838-A	Central Processing Unit (CPU)
2*	210-9832-A	Address Generation Unit (AGU)
3*	210-9833-A	Address Translation Unit (ATU)
4*	210-9834	Memory Control Unit (MCU)
5*	210-8703	Main Memory, 4 MB
	210-8703-1	Main Memory, 8 MB
	210-9874	Main Memory, 16 MB
	210-9874-1	Main Memory, 32 MB
6*	210-9836-1	System Bus Interface (SBI)
7*	210-8785-D	SMD IOC (23V98-1)
8*	210-9809-A	Serial IOC (23V67)
9*	210-8835	Support Control Unit (SCU)
10*		Optional Controller Boards
	210-8790-A	Kennedy Tape IOC (23V95-1)
	210-8491-A	Multiline TC Controller IOC (23V96)
	210-8789-A	Telex Tape IOC (23V95-2)
11	449-1467	Cover, Card Cage

* = Field Replaceable Item

12.2 VS-7010 Subassemblies

12.2.3 VS-7010 Computer Card Cage (Sheet 2 of 2)

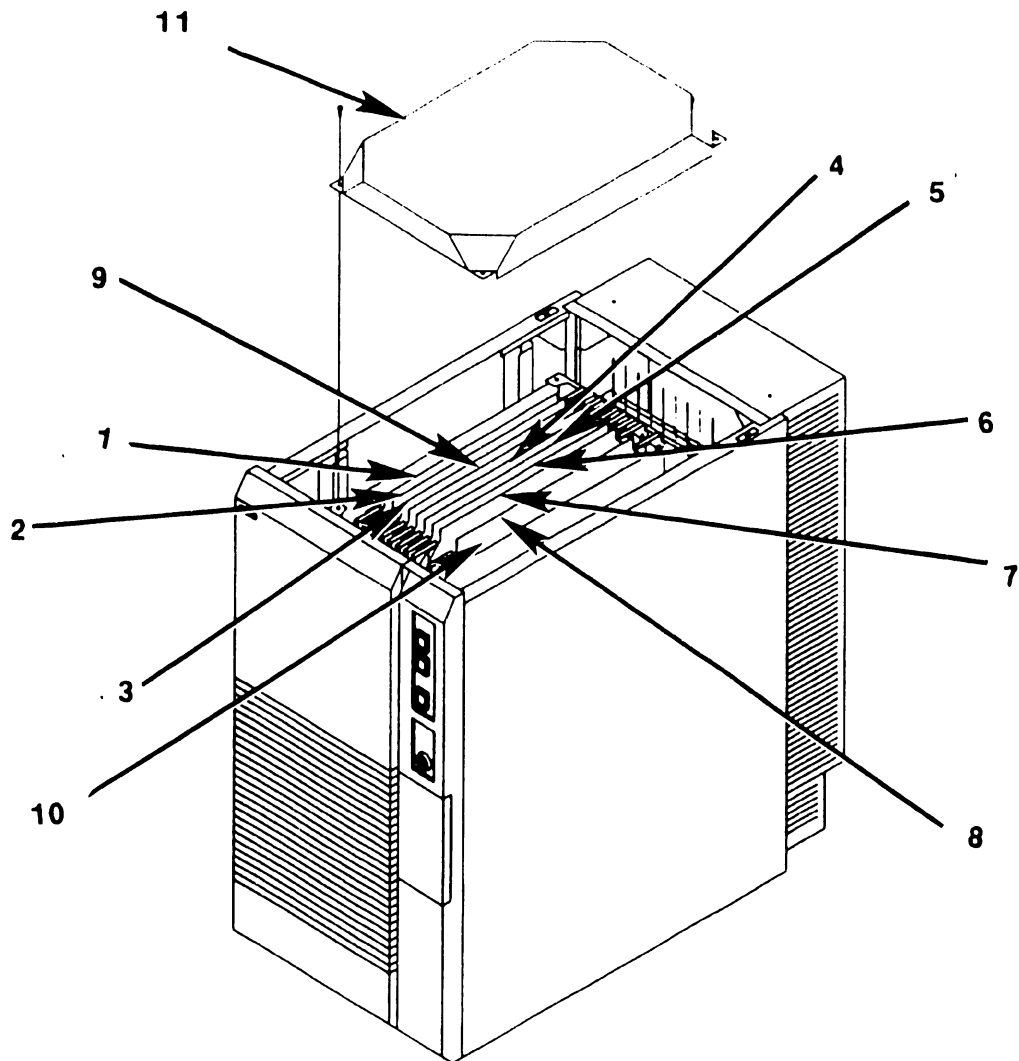

12.2 VS-7010 Subassemblies

12.2.4 VS-7010 Rear Panel Assembly (Sheet 1 of 2)

Item	Part Number	Description
1*	270-0975	Electrical APA, 4 each
2*	270-3451	DC Fans, 4 each
	* 220-2644	Cable, DC PDU to Rear Housing Terminal Block
3	449-1467	Cover, Card Cage
4	270-1102	Card Cage Assembly
5	447-0018	Shield, Bus Bar
6	270-1011	AC PDU Assembly
7		Optional Half Panels
	478-1202	Blank Half Panel
	452-4880	Panel, Cable Concentrator
	270-1005	Kennedy
	270-1007	Telex Tape
	* 270-1016	Gate Array TC Panel
	* 270-1004	Multiline TC Mounting Panel And SCL PCA (Requires Interface Modules;)
	* 270-1093	RS232 Interface Module, 4 each or
	* 270-1011	RS366 Interface Module, 4 each or
	* 270-1012	RS449 Interface Module, 4 each or
	* 270-1013	X.21 Interface Module, 4 each
8	270-1006	SMD Panel
		220-3544 'B' Cable (2 each)
		220-3545 'B' Cable (2 each)
		220-3546 'A' Cable

12.2 VS-7010 Subassemblies

12.2.4 VS-7010 Rear Panel Assembly (Sheet 2 of 2)

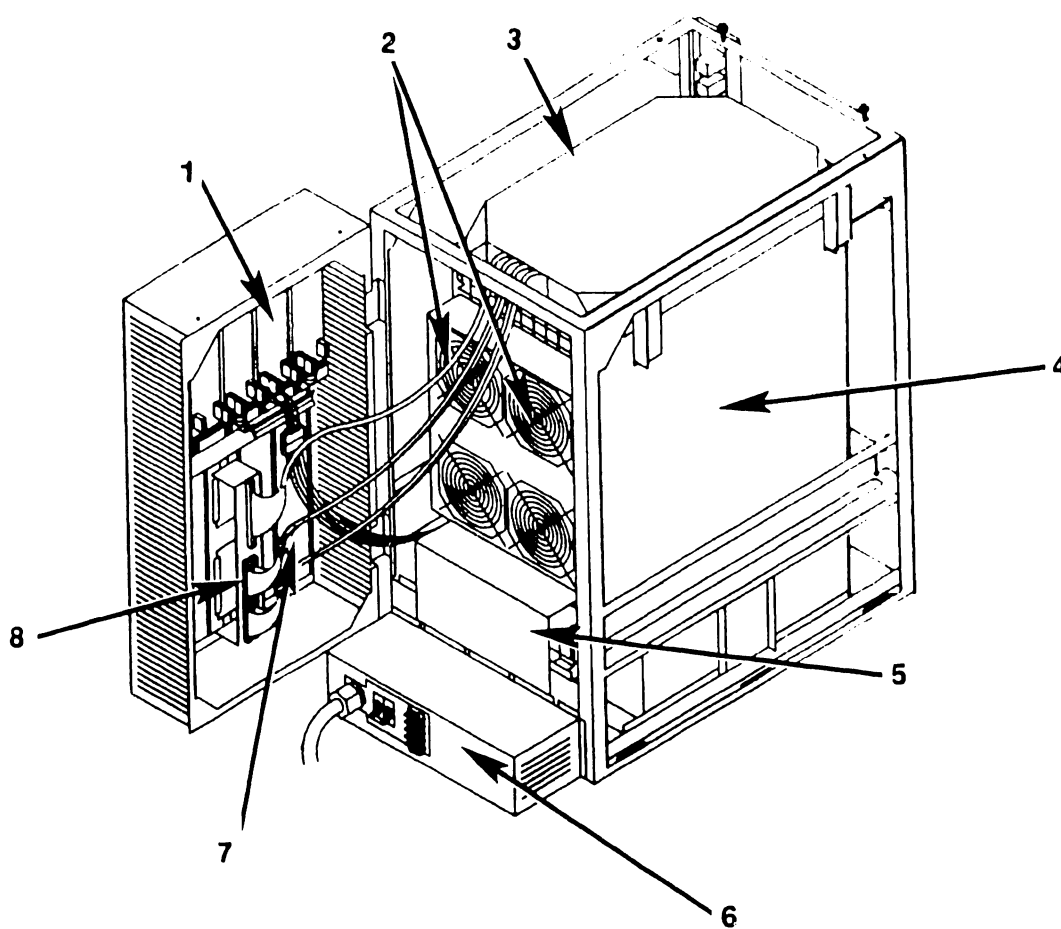

12.3 Support Control Unit Subassemblies

12.3.1 SCU Professional Computer (Sheet 1 of 2)

Item	Part Number	Description
1*	210-9521-2C	CPU/System Board (512K), VS-7010 Unique
2	458-3299	Enclosure, CPU
3	449-0748	Bezel, CPU
4	452-0342	Plate, Drive Mounting
5	449-0837	Adapter, Half Height Drive
6*	725-0142	Diskette Drive, 360KB Half Height
7*	278-4062	Winchester Disk, 20MB
8*	220-3240	Cable, Winchester 'A' Data
9*	220-3328	Cable, Winchester 'B' Control
10*	220-3239	Cable, Floppy Drive
11	458-3329	Chassis, CPU
12*	270-1033	Power Supply, SPS200
13*	210-9237	Motherboard
14	420-2040	AC Power Cord
15*	210-9025-A	Winchester Controller
16	458-3835	Shield, RF
17*	210-8310-A	Single Board Local Communications Controller
18*	210-9848	External PCI Controller
19*	210-9443-A	PC Emulator (Display Controller)
20	449-0753	Holddown, PCA

* = Field Replaceable Item

12.3 Support Control Unit Subassemblies

12.3.1 SCU Professional Computer (Sheet 2 of 2)

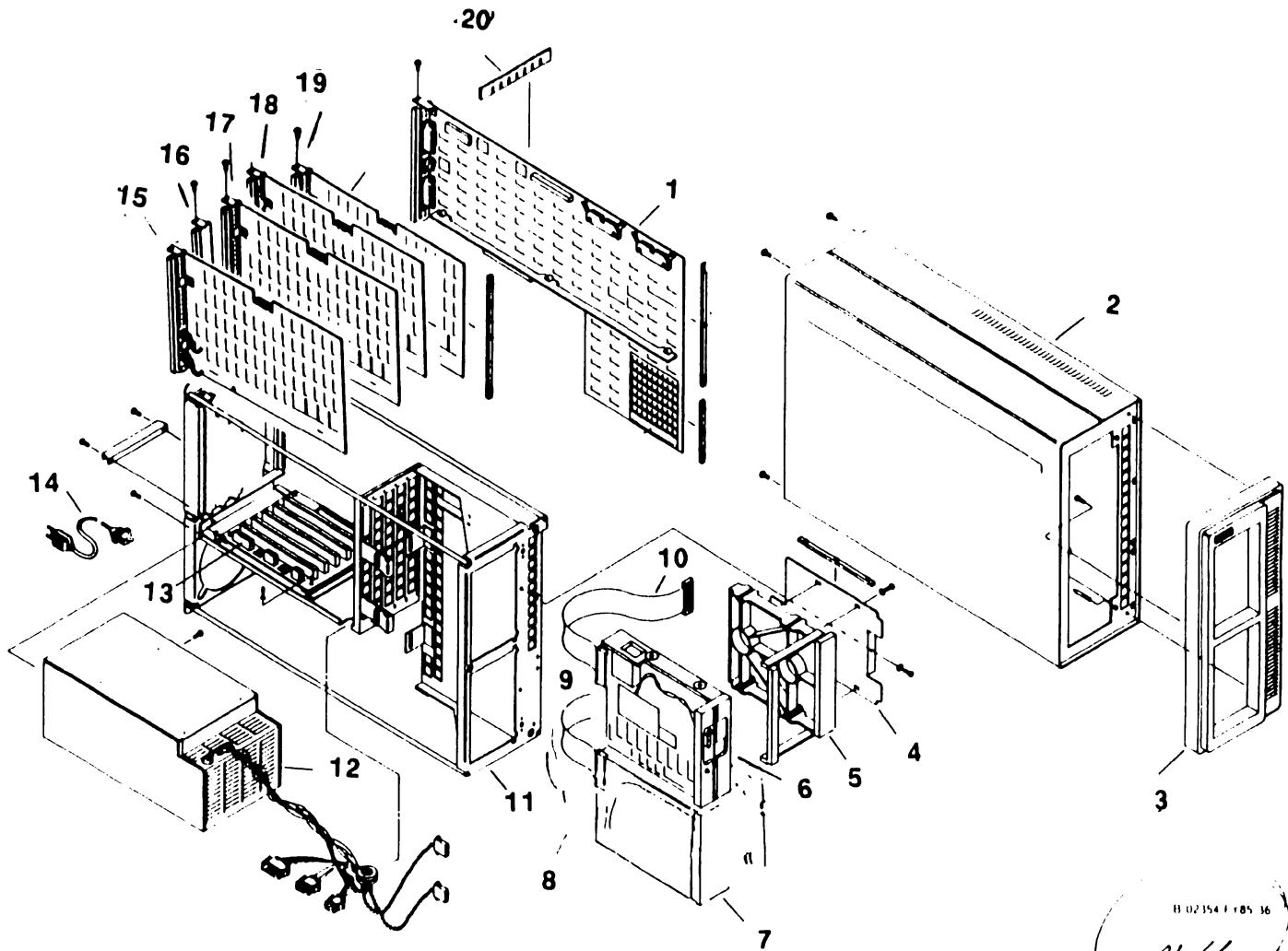

B 02354 F 05 16
Handwritten signature

12.3 Support Control Unit Subassemblies

12.3.1 SCU PM004L Monitor [279-0659] (Sheet 1 of 2)

Item	Part Number	Description
1	449-1065	Cover, PM004L Monitor
2	220-2311	Cable Assembly, Grounding
3	340-0115	Tube, C/R 12 inch
4	449-1064	Bezel, Monitor
5	650-9081	Screw, 1/4-28 x 1-1/2 inch hex head
6	449-1066	Actuator, Slide
7	449-0952	Bellow, Sleeve
8	449-0626	Collar, Ball Joint
9	478-0805	Ball Joint
10	449-1067	Base, Monitor
11	449-0625	Cap, Spring
12	652-0064	Stop Nut, 1/4-28
13	220-0491	Cable Assembly, 4 feet 4 inch
	220-0495	Cable Assembly, 8 feet 8 inch
14*	210-8514	PCB, Monitor Electronics
15	320-0132	Yoke Assembly (Less Magnets)

* = Field Replaceable Item

12.3 Support Control Unit Subassemblies

12.3.2 SCU PM004L Monitor [279-0659] (Sheet 2 of 2)

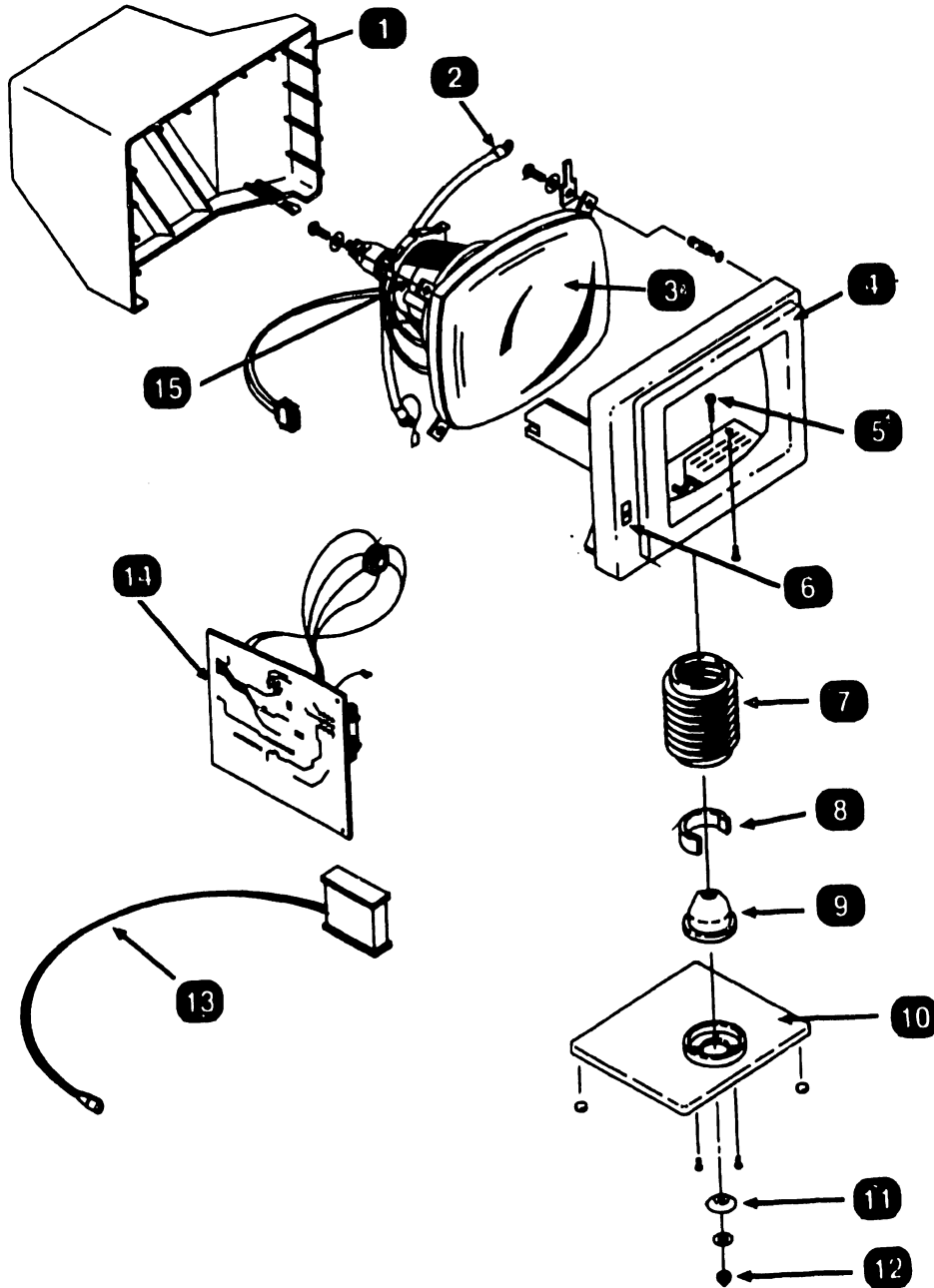

12.4 VS-7010 Power Interconnect

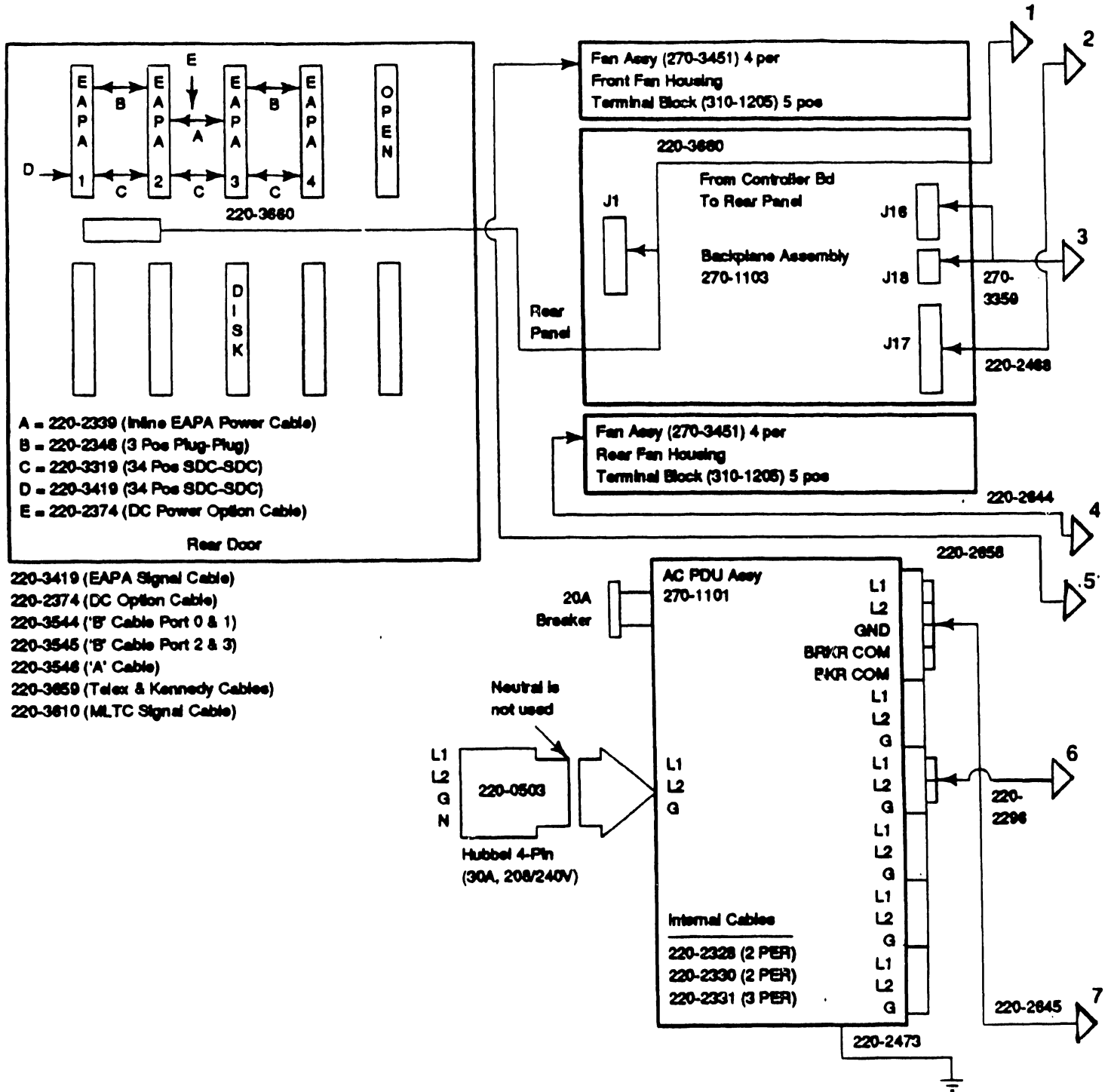

12.4 VS-7010 Power Interconnect

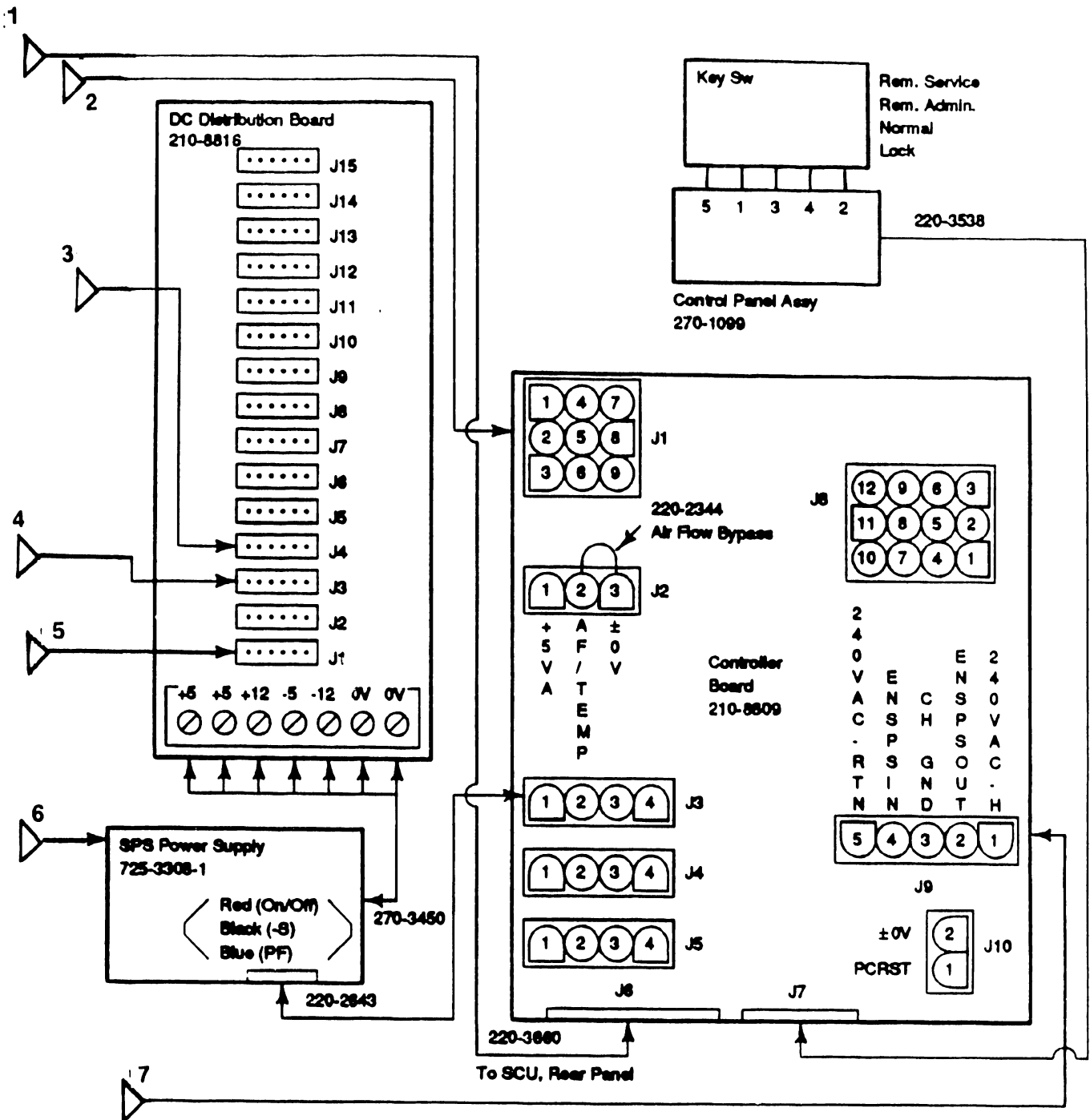

12.5 Cable Assemblies

12.5.1 Standard Cable Assemblies

Cable P/N	Source	Destination
220-0503	208/240V AC Power Receptacle	Mainframe AC PDU
220-2296	AC PDU Connector	Power Supply
220-2339	In-Line EAPA Power 'Y'	EAPA Power Connectors
220-2346	EAPA Power Connector	Adjacent EAPA Power Connector
220-2374	DC PDU Connector	Rear Door Option Panels
220-2468	Motherboard	Power Supply Controller Board J1
220-2473	AC PDU Ground	Chassis Ground Stud
220-2643	Power Supply (On/Off)	Power Supply Controller Board J3
220-2644	DC PDU Connector	Rear Fan Housing Terminal Block
220-2645	AC PDU Connector	Power Supply Controller Board J9
220-2658	DC PDU Connector	Front Fan Housing Terminal Block
220-3319	EAPA Signal Connector	Adjacent EAPA Signal Connector
220-3419	Serial IOC Connector J2	First EAPA Signal Connector
220-3472	IOC 50-Pin Connector (CPU-to-AGU, AGU-to-ATU)	Adjacent IOC 50-Pin Connector
220-3538	Control Panel Assembly (Part of Assembly 270-1099)	Power Supply Controller Board J9
220-3660	Power Supply Controller J6	Motherboard/Rear Panel SCU Port
270-3359	DC PDU Connector	Motherboard Connector
270-3450	Power Supply DC Harness	DC PDU Terminal Block
220-2344	Power Supply Controller J3 (Included as part of Power Supply Controller Board)	
420-2040	120V AC Power Receptacle	SCU (PC) Power Supply
220-0606	Mainframe SCU Interface Port (Standard cable 10 ft, or optional 25 ft cable P/N 220-0607)	SCU (PC) SCU Interface Board

12.5 Cable Assemblies

12.5.2 Optional Cable Assemblies

Cable P/N	Source	Destination
220-3546	SMD IOC Connector J5	SMD Panel Data 'A' Cable
220-3544	SMD IOC Connector J4	SMD Panel Control Port 0 'B' Cable
220-3544	SMD IOC Connector J3	SMD Panel Control Port 1 'B' Cable
220-3545	SMD IOC Connector J2	SMD Panel Control Port 2 'B' Cable
220-3545	SMD IOC Connector J1	SMD Panel Control Port 3 'B' Cable
220-3659	Telex/Kennedy IOC (50-Pin Cable Soc-Soc)	Kennedy/Telex Panels
220-3610	Multiline TC IOC Connectors J1 - J4	Multiline Half Panel SCL



LABORATORIES, INC

ONE INDUSTRIAL AVENUE, LOWELL, MASSACHUSETTS 01851 TEL (617) 459 5000 TWX 710 343 6769 TELEX 94 7421

PRINTED IN U.S.A.

END