

IBM



Hardware Maintenance Manual Type 6029

IBM



Hardware Maintenance Manual Type 6029

Note:

Before using this information and the product it supports, be sure to read the general information un

First Edition (March 2002)

INTERNATIONAL BUSINESS MACHINES CORPORATION PROVIDES THIS PUBLICATION "AS IS" WITHOUT ANY WARRANTY OF ANY KIND, EITHER EXPRESS OR IMPLIED, INCLUDING, BUT NOT LIMITED TO, THE LIMITED WARRANTIES OF MERCHANTABILITY OR FITNESS FOR A PARTICULAR PURPOSE. Some jurisdictions do not allow disclaimers or express or implied warranties in certain transactions; therefore, this statement may not apply to you.

This publication could include technical inaccuracies or typographical errors. Changes are periodically made to the information herein; these changes will be incorporated in new editions of the publication. IBM may make improvements or changes in the products or the programs described in this publication at any time.

Requests for technical information about IBM products should be made to your IBM Authorized Dealer or your IBM Marketing Representative.

© Copyright International Business Machines Corporation 2001. All rights reserved.

US Government Users Restricted Rights – Use, duplication or disclosure restricted by GSA ADP Schedule Contract with IBM Corp.

Contents

Chapter 1. About this manual	1
Important Safety Information	1

Chapter 2. General Checkout.	3
---	----------

Chapter 3. General information.	5
Features	5
Physical specifications	8
Available options	9

Chapter 4. Diagnostics	11
Setup Utility program	12
Product Recovery Program menu	13
Diagnostics	14
Diagnostics program download.	14
Navigating through the diagnostics programs	14
Running diagnostics tests.	14
Test selection	14
Test results	15
Hard file Smart test.	15
Quick and Full erase - hard drive	17
Viewing the test log	17

Chapter 5. Installing Options	19
Installing external options	19
Locating connectors on the front of the computer	20
Locating connectors on the rear of the computer	22
Obtaining device drivers	22
Installing internal options	22
Removing the cover	23
Locating components	24
Identifying parts on the system board	25
Installing memory	25
Installing and removing adapters	27
Installing and removing internal drives	29
To connect the first IDE CD drive or DVD drive	31
To connect an additional IDE CD drive or DVD	32
drive	32
To connect an additional IDE hard disk drive	32
Changing the battery	32
Replacing the cover and connecting the cables.	33

Chapter 6. FRU Removals	35
Replacing a microprocessor	35
Removals	35
Front bezel	35
Hard disk drive	36

Power supply	37
System board.	38

Chapter 7. Symptom-to-FRU Index.	39
---	-----------

Hard disk drive boot error	39
Power Supply Errors	39
Diagnostic error codes.	41
Beep symptoms	59
No-beep symptoms.	61
POST error codes	62
Miscellaneous error messages	77
Undetermined problems	79

Chapter 8. Parts listing.	85
--	-----------

Chapter 9. Additional Service Information.	87
---	-----------

Security features.	87
Passwords.	87
Vital product data	88
Management Information Format (MIF)	88
Alert on LAN	89
BIOS levels	89
Flash (BIOS/VPD) update procedure	89
Flash recovery boot block jumper	90
Power management	91
Automatic configuration and power interface	
(ACPI) BIOS	91
Advanced Power Management	91
Automatic Hardware Power Management	
features.	91
Setting Automatic Hardware Power Management	
features.	91
Automatic Power-On features	92

Chapter 10. Related service information 93
--

Safety information	93
General safety	93
Electrical safety	94
Safety inspection guide	95
Handling electrostatic discharge-sensitive devices	96
Grounding requirements	97
Safety notices (multi-lingual translations)	124
Send us your comments!	126
Problem determination tips.	127
Notices	127
Trademarks	128

Chapter 1. About this manual

This manual contains service and reference information for IBM® computer Type 6029.

This manual is divided into product service sections and a related service section, as follows:

- The product service sections include procedures for isolating problems to a FRU, a Symptom-to-FRU Index, additional service information and an illustrated parts catalog.
- The related service section includes safety notices and safety information, and problem determination tips.

Note:

This manual is intended for trained servicers who are familiar with IBM Personal Computer products. Use this manual along with advanced diagnostic tests to troubleshoot problems effectively.

Before servicing an IBM product, be sure to review the "Safety information" on page 93.

Important Safety Information

Be sure to read all caution and danger statements in this book before performing any of the instructions.

Prenez connaissance de toutes les consignes de type Attention et Danger avant de procéder aux opérations décrites par les instructions.

Lesen Sie alle Sicherheitshinweise, bevor Sie eine Anweisung ausführen.

주의 및 위험 경고문(한글)

중요:

이 책에 나오는 모든 주의 및 위험 경고문은 번호로 시작됩니다. 이 번호는 *Safety Information* 책에 나오는 영문판 주의 및 위험 경고문과 한글판 주의 및 위험 경고문을 상호 참조하는데 사용됩니다.

예를 들어 주의 경고문이 번호 1로 시작되면 *Safety Information* 책에서 이 주의 경고문은 경고문 1번 아래에 나옵니다.

지시를 따라 수행하기 전에 먼저 모든 주의 및 위험 경고문을 읽도록 하십시오.

Accertarsi di leggere tutti gli avvisi di attenzione e di pericolo prima di effettuare qualsiasi operazione.

Leia todas as instruções de cuidado e perigo antes de executar qualquer operação.

Lea atentamente todas las declaraciones de precaución y peligro ante de llevar a cabo cualquier operación.

注意和危险声明 (简体中文)

重要事项:

本书中的所有注意和危险声明之前都有编号。该编号用于英语的注意或危险声明与 *Safety Information* 一书中可以找到的翻译版本的注意或危险声明进行交叉引用。

例如，如果一个注意声明以编号 1 开始，那么对该注意声明的翻译出现在 *Safety Information* 一书中的声明 1 中。

在按说明执行任何操作前，请务必阅读所有注意和危险声明。

注意及危險聲明 (中文)

重要資訊：

本書中所有「注意」及「危險」的聲明均以數字開始。此一數字是用來作為交互參考之用，英文「注意」或「危險」聲明可在「安全資訊」(Safety Information) 一書中找到相同內容的「注意」或「危險」聲明的譯文。

例如，有一「危險」聲明以數字 1 開始，則該「危險」聲明的譯文將出現在「安全資訊」(Safety Information) 一書的「聲明」1 中。

執行任何指示之前，請詳讀所有「注意」及「危險」的聲明。

Chapter 2. General Checkout

This general checkout procedure is for Type 6029 computers.

Attention:

The drives in the computer you are servicing might have been rearranged or the drive startup sequence changed. Be extremely careful during write operations such as copying, saving or formatting. Data or programs can be overwritten if you select an incorrect drive.

Diagnostic error messages appear when a test program finds a problem with a hardware option. For the test programs to properly determine if a test *Passed*, *Failed* or *Aborted*, the test programs check the error-return code at test completion. See "Diagnostics" on page 14.

General error messages appear if a problem or conflict is found by an application program, the operating system, or both. For an explanation of these messages, refer to the information supplied with that software package.

Notes:

- Type 6029 computers default to come up quiet (no beep and no memory count and checkpoint code display) when no errors are detected by POST.
- To enable beep and memory count and checkpoint code display when a successful POST occurs, do the following:
 1. Select **Start Options** in the Configuration/Setup Utility program (see "Setup Utility program" on page 12).
 2. Set **Power-On Self-Test** to **Enhanced**.
- Before replacing any FRUs, ensure that the latest level of BIOS is installed on the system. A down-level BIOS might cause false errors and unnecessary replacement of the system board. For more information on how to determine and obtain the latest level BIOS, see "BIOS levels" on page 89.
- If multiple error codes are displayed, diagnose the first error code displayed.
- If the computer hangs with a POST error, go to "Symptom-to-FRU Index" on page 39.
- If the computer hangs and no error is displayed, go to "Undetermined problems" on page 79.
- If an installed device is not recognized by the diagnostics program, that device might be defective.

001

1. Power-off the computer and all external devices.
2. Check all cables and power cords.
3. Make sure the system board is seated properly.
4. Set all display controls to the middle position.
5. Power-on all external devices.
6. Power-on the computer.
7. Check for the following response:
 - Readable instructions or the Main Menu.

DID YOU RECEIVE THE CORRECT RESPONSE?

If NO, continue to **002** .

If YES, proceed to **003** .

002

If the Power Management feature is enabled, do the following:

1. Start the Configuration/Setup Utility program (see "Setup Utility program" on page 12)
2. Select **Power Management** from the Configuration/Setup Utility program menu.
3. Select **APM**.
4. Be sure **APM BIOS Mode** is set to **Disabled**. If it is not, press Left Arrow (←) or Right Arrow (→) to change the setting.
5. Select **Automatic Hardware Power Management**.
6. Set **Automatic Hardware Power Management** to **Disabled**.
7. If the problem persists, continue to **003** .

003

Run the Diagnostic programs. If necessary, refer to "Diagnostics" on page 14.

- If you receive an error, replace the part that the diagnostic program calls out or go to "Symptom-to-FRU Index" on page 39.
- If the test stops and you cannot continue, replace the last device tested.

Chapter 3. General information

This IBM® computer incorporates many of the latest advances in computer technology and can be upgraded as your needs change.

Adding hardware options to your computer is an easy way to increase its capabilities. Instructions for installing external and internal options are included in this publication. When adding an option, use these instructions along with the instructions that come with the option.

Go to Access IBM for general information about the use, operation, and maintenance of your computer. Access IBM also contains information to help solve problems and get repair service or other technical assistance.

Features

This section provides an overview of the computer features, preinstalled software, and specifications.

Microprocessor

Intel® Celeron™ processor with 128 KB of internal L2 cache memory and MMX™ technology or Intel Celeron processor with 256 KB of internal L2 cache memory and MMX technology

Memory

- Support for two dual in-line memory modules (DIMMs)
- 512 KB flash memory for system programs

Internal drives

- 3.5-inch, 1.44 MB diskette drive
- Internal hard disk drive
- CD-ROM, DVD-ROM, or CD-RW drive.

Video subsystem

Dynamic video memory technology

Audio subsystem

16-bit integrated Sound Blaster Pro compatible audio subsystem

Connectivity

- 10/100 Mbps integrated Intel ethernet controller that supports the Wake on LAN® feature
- 56k V.90 data/fax PCI modem (some models)

System management features (varies by model)

- Remote Program Load (RPL) and Dynamic Host Configuration Protocol (DHCP)
- Wake on LAN
- Wake on Ring (in the IBM Setup Utility program, this feature is called Serial Port Ring Detect for an external modem and Modem Ring Detect for an internal modem)

- Remote Administration
- Automatic power-on startup
- System Management (SM) BIOS and SM software
- Ability to store POST hardware test results

Input/output features

- 25-pin, Extended Capabilities Port (ECP)/Extended Parallel Port (EPP)
- Two 9-pin serial connectors
- Four 4-pin, USB connectors
- PS/2[®] mouse connector
- PS/2 keyboard connector
- Ethernet connector
- Monitor connector
- Three audio connectors (line in, line out, and microphone)

Expansion

- Four drive bays
- Three 32-bit peripheral component interconnect (PCI) adapter slots

Power

- 145 W power supply with manual voltage selection switch
- Automatic 50/60 Hz input frequency switching
- Advanced Power Management support
- Advanced Configuration and Power Interface (ACPI) support

Security features (varies by model)

- User and administrator passwords
- Support for the addition of a Rope Clip and lockable cable
- Startup sequence control
- Startup without diskette drive, keyboard, or mouse
- Unattended start mode
- Diskette and hard disk I/O control
- Serial and parallel port I/O control
- Security profile by device

IBM preinstalled software

The computer might come with preinstalled software. If it does, an operating system, device drivers to support built-in features, and other support programs are included.

Operating systems (supported)

- Microsoft[®] Windows XP Pro
- Microsoft[®] Windows XP Home
- Microsoft Windows 2000
- Microsoft Windows 98 Second Edition

Operating systems (tested for compatibility)¹

- Microsoft Windows NT[®] Workstation Version 4.0
- Microsoft Windows Millennium Edition (Me)
- Microsoft Windows 98

Physical specifications

This section lists the physical specifications of the computer.

1. The operating systems listed here are being tested for compatibility at the time this publication goes to press. Additional operating systems might be identified by IBM as compatible with your computer following the publication of this booklet. Corrections and additions to this list are subject to change. To determine if an operating system has been tested for compatibility, check the Web site of the operating system vendor.

<p>Dimensions</p> <p>Height: 393 mm (15.5 in.)</p> <p>Width: 179 mm (7 in.)</p> <p>Depth: 393 mm (15.5 in.)</p> <p>Weight</p> <p>Minimum configuration as shipped: 9.1 kg (20 lb)</p> <p>Maximum configuration: 10.2 kg (22.5 lb)</p> <p>Environment</p> <p>Air temperature:</p> <p>System on: 10° to 35°C (50° to 95° F)</p> <p>System off: 10° to 43°C (50° to 110° F)</p> <p>Maximum altitude: 2134 m (7000 ft)</p> <p>Note: The maximum altitude, 2134 m (7000 ft), is the maximum altitude at which the specified air temperatures apply. At higher altitudes, the maximum air temperatures are lower than those specified.</p> <p>Humidity:</p> <p>System on: 8% to 80%</p> <p>System off: 8% to 80%</p> <p>Electrical input</p> <p>Input voltage:</p> <p>Low range:</p> <p>Minimum: 90 V ac</p> <p>Maximum: 137 V ac</p> <p>Input frequency range: 57–63 Hz</p> <p>Voltage switch setting: 115 V ac</p> <p>High range:</p> <p>Minimum: 180 V ac</p> <p>Maximum: 265 V ac</p> <p>Input frequency range: 47–53 Hz</p> <p>Voltage switch setting: 230 V ac</p> <p>Input kilovolt-amperes (kVA) (approximate):</p> <p>Minimum configuration as shipped: 0.08 kVA</p> <p>Maximum configuration: 0.3 kVA</p> <p>Note: Power consumption and heat output vary depending on the number and type of optional features installed and the power-management optional features in use.</p>	<p>Heat output (approximate) in British thermal units (BTU) per hour:</p> <p>Minimum configuration: 188 BTU/hr (55 watts)</p> <p>Maximum configuration: 256 BTU/hr (75 watts)</p> <p>Airflow</p> <p>Approximately 0.79 cubic meters every 3 minutes (28 cubic feet every 3 minutes) maximum</p> <p>Acoustical noise-emission values</p> <p>Average sound-pressure levels:</p> <p>At operator position:</p> <p>Idle: 38 dBA</p> <p>Operating: 43 dBA</p> <p>At bystander position - 1 meter (3.3 ft):</p> <p>Idle: 33 dBA</p> <p>Operating: 37 dBA</p> <p>Declared (upper limit) sound-power levels:</p> <p>Idle: 4.8 bels</p> <p>Operating: 5.1 bels</p> <p>Note: These levels were measured in controlled acoustical environments according to the procedures specified by the American National Standards Institute (ANSI) S12.10 and ISO 7779 and are reported in accordance with ISO 9296. Actual sound-pressure levels in a given location might exceed the average values stated because of room reflections and other nearby noise sources. The declared sound-power levels indicate an upper limit, below which a large number of computers will operate.</p> <p>Note: The computer is classified as a Class A or Class B digital device. See the <i>Quick Reference</i> for further information about this classification.</p>
--	--

Available options

The following are some available options:

- External options
 - Parallel port devices, such as printers and external drives
 - Serial port devices, such as external modems and digital cameras
 - Audio devices, such as external speakers for the sound system
 - USB devices, such as printers, joysticks, and scanners
 - Security device, such as a rope clip
 - Monitors
- Internal options
 - System memory, called dual inline memory modules (DIMMs)
 - Peripheral component interconnect (PCI) adapters
 - Internal drives, such as:
 - CD drive or DVD drive
 - CD drive and DVD drive
 - Hard disk
 - Diskette drives and other removable media drives

For the latest information about available options, see the following World Wide Web pages:

- <http://www.ibm.com/pc/us/options/>
- <http://www.ibm.com/pc/support/>

You can also obtain information by calling the following telephone numbers:

- Within the United States, call 1-800-IBM-2YOU (1-800-426-2968), your IBM reseller, or IBM marketing representative.
- Within Canada, call 1-800-565-3344 or 1-800-IBM-4YOU.
- Outside the United States and Canada, contact your IBM reseller or IBM marketing representative.

Chapter 4. Diagnostics

The following tools are available to help identify and resolve hardware-related problems.

- Setup Utility program
- Power-On Self-Test (POST)
 - POST Beep Codes
 - Error Code Format
- Diagnostics program
- Recovery utility
 - Full recovery
 - Partial recovery
- Repair utility

Setup Utility program

Attention:

A customized setup configuration (other than default settings) might exist on the computer you are servicing. Running the Setup Utility program might alter those settings. Note the current configuration settings and verify that the settings are in place when service is complete.

The Setup Utility (configuration) program is stored in the permanent memory of the computer. This program includes settings for the following:

- System Summary
- Product Data
- Devices and I/O Ports
- Start Options
- Date and Time
- System Security
- Advanced Setup
- Power Management

To run the Setup Utility program, use the following procedure.

1. Power-off the computer and wait for a few seconds until all in-use lights go off.
2. Power-on the computer.
3. When the Setup Utility prompt appears on the screen during start-up, press **F1**. The Setup Utility menu will appear.
4. Follow the instructions on the screen.
5. When finished, select **System Summary** to verify that any configuration changes have been accepted.

Product Recovery Program menu

Type 6029 machines have recovery and diagnostics programs on a separate hard drive partition. The Enhanced Diagnostics diskette is not shipped with the machine. To download the Diagnostics program, see “Diagnostics program download” on page 14.

At startup, the machine displays the following prompt:

To start the Product Recovery Program, press F11

Attention: Make sure all data is backed up to avoid loss when the Product Recovery program is used.

After depressing F11, you are given the following options.

- **Full recovery**

This utility reformats the hard drive and restores all original files.

- **System utilities**

1. **Repair (Windows NT 4.0 and 2000 Only)**

This runs the Windows NT 4.0 emergency repair utility.

2. **Run Diagnostics**

Runs the IBM Enhanced Diagnostic Program.

3. **Create a Diagnostics Diskette**

Creates a bootable diagnostic diskette.

4. **System Information**

Displays information about your computer configuration and allows the user to gather system information that would be needed during a Help Center call.

5. **Create Recovery/Repair Diskette (Disk to Disk Solution Only)**

Creates a startable diskette to restore access to the IBM Product Recovery program on the hard disk.

6. **Recovery CD**

In the event of a Hard Disk Drive failure, a Recovery CD can be used to restore the Hard Disk Drive to the original factory preset. Be sure to use the Recovery CD FRU list to obtain the proper recovery CD for the computer model you are servicing.

Diagnostics

The Diagnostics program uses a full range of diagnostic utilities to determine the operating condition of the computer's hardware components.

For a complete list of error codes and messages, see "Symptom-to-FRU Index" on page 39.

Diagnostics program download

To download the Diagnostics program, do the following:

- Go to <http://www.ibm.com/>.
- Select **Support**.
- Select **Personal computing** from the "Get product support for" pull-down menu.
- Search for the machine type in the "Quick Path" box on the left.
- Select **Downloadable files** from the options on the left.
- Select **Diagnostics** from the pull down menu.

Navigating through the diagnostics programs

Use the cursor movement keys to navigate within the menus.

- The **Enter** key is used to select a menu item.
- The **Esc** key is used to back up to the previous menu.
- For online help select **F1**.

Running diagnostics tests

There are four ways to run the diagnostic tests.

1. Using the cursor movement keys, highlight **Run Normal Test** or **Run Quick Test** from the Diagnostics menu and then press **Enter**.
This will automatically run a pre-defined group of tests from each test category. **Run Normal Test** runs a more extensive set of tests than does **Run Quick Test** and takes longer to execute.
2. Press **F5** to automatically run all selected tests in all categories. See "Test Selection".
3. From within a test category, press **Ctrl-Enter** to automatically run only the selected tests in that category. See "Test Selection".
4. Using the cursor movement keys, highlight a single test within a test category, then press **Enter**. This will run only that test.

Press **Esc** at any time to stop the testing process.

Test results, (N/A, PASSED, FAILED, ABORTED), are displayed in the field beside the test description and in the test log. See "Viewing the test log" on page 17.

Test selection

To select one or more tests, use the following procedure.

1. Open the corresponding test category.
2. Using the cursor movement keys, highlight the desired test.
3. Press the space bar.

A selected test is marked by >>. Pressing the space bar again de-selects a test and removes the chevron.

- Repeat steps 2 and 3 above to select all desired tests.

Test results

Diagnostics test results will produce the following error code format:

Function Code	Failure Type	DeviceID	Date	ChkDigits	Text
---------------	--------------	----------	------	-----------	------

- **Function Code:**
Represents the feature or function within the PC.
- **Failure Type:**
Represents the type of error encountered.
- **DeviceID:**
Contains the component's unit-ID which corresponds to either a fixed disk drive, removable media drive, serial or parallel port, processor, specific RIMM, or a device on the PCI bus.
- **Date:**
Contains the date on which the diagnostic test was run. The date is retrieved from CMOS and displayed using the YYYYMMDD format.
- **ChkDigits:**
Contains a 2-digit check-digit value to ensure the following:
 - Diagnostics were run on the specified date.
 - Diagnostics were run on the specified IBM computer.
 - The diagnostic error code is recorded correctly.
- **Text:**
Description of the error.

Note: See "Diagnostic error codes" on page 41 for error code listings.

Hard file Smart test

Use the Hard File Smart Test when the system management tool has detected a hard file SMART alert.

The Smart test does the following:

- Interrogates IDE devices for support of the SMART instruction set.
- Issues a ENABLE SMART command to make sure SMART functionality is active.
- Checks the SMART RETURN STATUS command to determine if any thresholds have been exceeded.

If thresholds have been exceeded, an error message is shown, and the test fails. If no SMART is supported by the drive, the test returns with "N/A".

Quick and Full erase - hard drive

The Diagnostics program offers two hard drive format utilities:

- Quick Erase Hard Drive
- Full Erase Hard Drive

The Quick Erase Hard Drive provides a DOS utility that performs the following steps.

- Destroys the Master Boot Record (MBR) on the hard drive.
- Destroys all copies of the FAT Table on all partitions (both the master and backup).
- Destroys the partition table.
- Provides messages that warn the user that this is a non-recoverable process.

The Full Erase Hard Drive provides a DOS utility that performs the following steps.

- Performs all the steps in Quick Erase.
- Provides a DOS utility that writes random data to all sectors of the hard drive.
- Provide an estimate of time to completion along with a visual representation of completion status.
- Provides messages that warn the user about non-recoverable process.

Important: Make sure that all data is backed up before using the Quick or Full Erase functions.
--

To select the Quick Erase or Full Erase Hard Drive utility, use the following procedure.

1. Select the UTILITY option on the toolbar and press **Enter**.
2. Select either the QUICK ERASE or FULL ERASE HARD DISK option and follow the instructions.

Viewing the test log

Errors reported by the diagnostic test will be displayed by the program as a failed test.

To view details of a failure or to view a list of test results, use the following procedure from any test category screen.

- Press **F3** to activate the log file.
- Press **F3** again to save the file to diskette or **F2** to print the file.

Chapter 5. Installing Options

Installing external options

This chapter shows the various external connectors on the computer to which can be attached external options, such as external speakers, a printer, or a scanner. For some external options, additional software must be installed in addition to making the physical connection. When adding an external option, use the information in this chapter to identify the required connector, and then use the instructions that come with the option to help make the connection and install any software or device drivers that are required for the option.

Important: Before you install or remove any option, read “Safety information” on page 93. These precautions and guidelines will help you work safely.

Locating connectors on the front of the computer

The following illustration shows the locations of the USB connectors on the front of the computer.

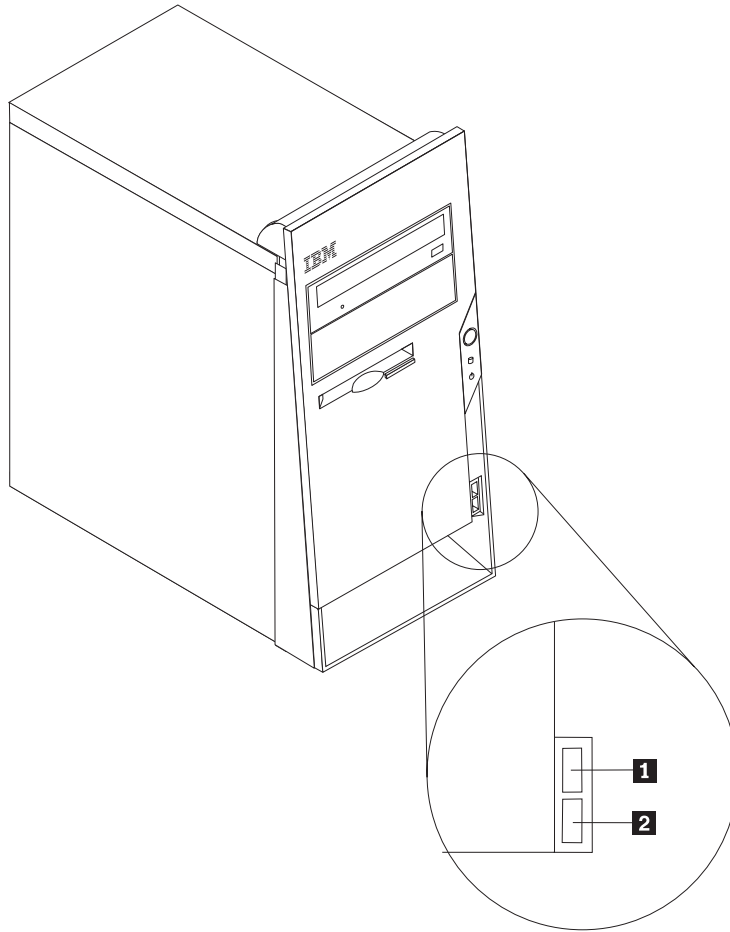

1 and **2** USB connectors

Locating connectors on the rear of the computer

The following illustration shows the locations of the connectors on the back of the computer.

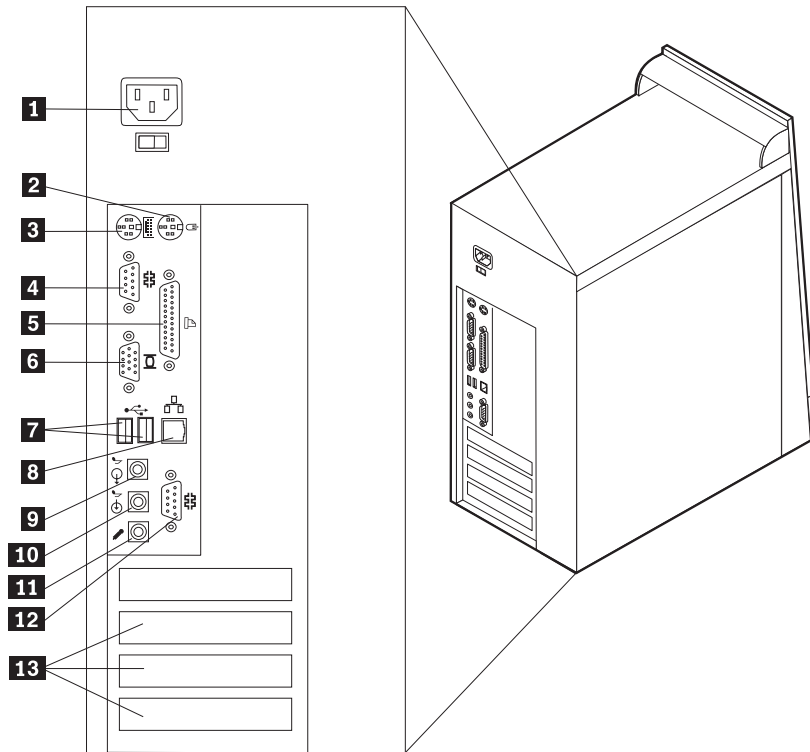

- | | | | |
|---|--------------------|----|--------------------------|
| 1 | Power connector | 8 | Ethernet connector |
| 2 | Mouse connector | 9 | Audio line out connector |
| 3 | Keyboard connector | 10 | Audio line in connector |
| 4 | Serial connector | 11 | Microphone connector |
| 5 | Parallel connector | 12 | Serial connector |
| 6 | Monitor connector | 13 | PCI slots |
| 7 | USB connectors | | |

Note: Some connectors on the rear of the computer are color-coded to help determine where to connect the cables on the computer.

Connector	Description
Mouse connector	Used to attach a mouse, trackball, or other pointing device that uses a standard mouse connector.
Keyboard connector	Used to attach a keyboard that uses a standard keyboard connector.
Serial connectors	Used to attach an external modem, serial printer, or other devices that use a 9-pin serial connector.
Parallel connector	Used to attach a parallel printer, parallel scanner, or other devices that use a 25-pin parallel connector.
USB connectors	Used to attach a device that requires a Universal Serial Bus (USB) connection, such as a USB scanner or USB printer. If there are more than four USB devices, you can purchase a USB hub, which can be used to connect additional USB devices.
Ethernet connector	Used to attach an Ethernet cable for a local area network (LAN). Note: To operate the computer within FCC Class B limits, use a Category 5 Ethernet cable.
Audio line out connector	Used to send audio signals from the computer to external devices, such as powered stereo speakers (speakers with built-in amplifiers), headphones, multimedia keyboards, or the audio line in connector on a stereo system or other external recording device.
Audio line in connector	Used to receive audio signals from an external audio device, such as a stereo system. When an external audio device is attached, a cable is connected between the audio line out connector of the device and the audio line in connector of the computer.
Microphone connector	Used to attach a microphone to the computer when recording voice or other sounds on the hard disk if speech-recognition software is used.

Obtaining device drivers

Device drivers can be obtained for operating systems that are not preinstalled at <http://www.ibm.com/pc/support/> on the World Wide Web. Installation instructions are provided in README files with the device driver files.

Installing internal options

The capabilities of the computer can be expanded by adding memory, drives, or adapters. When installing an option, use these instructions along with the instructions that come with the option.

Removing the cover

Important:

See “Safety information” on page 93 and “Handling electrostatic discharge-sensitive devices” on page 96 before you begin.

To remove the cover:

1. Shut down the operating system, remove any media (diskettes, CDs, or tapes) from the drives, and turn off all attached devices and the computer.
2. Unplug all power cords from electrical outlets.
3. Disconnect all cables attached to the computer. This includes power cords, input/output (I/O) cables, and any other cables that are connected to the computer.
4. Remove the two screws at the rear of the left side cover and slide the cover to the rear to remove.

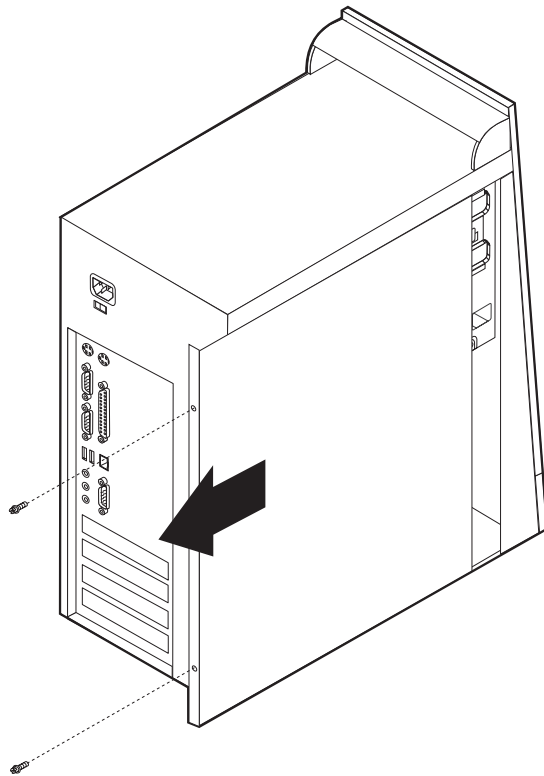

Locating components

The following illustration will help you locate the various components in the computer.

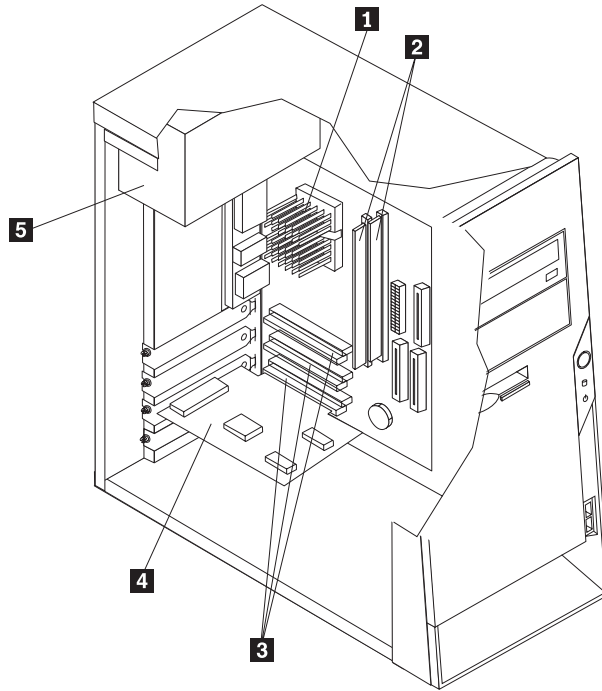

1 Microprocessor and heat sink

2 DIMMs

3 PCI slots

4 PCI adapter

5 Power supply

Identifying parts on the system board

The system board is the main circuit board in the computer. It provides basic computer functions and supports a variety of devices that are IBM-installed or that can be installed later.

The following illustration shows the locations of parts on the system board.

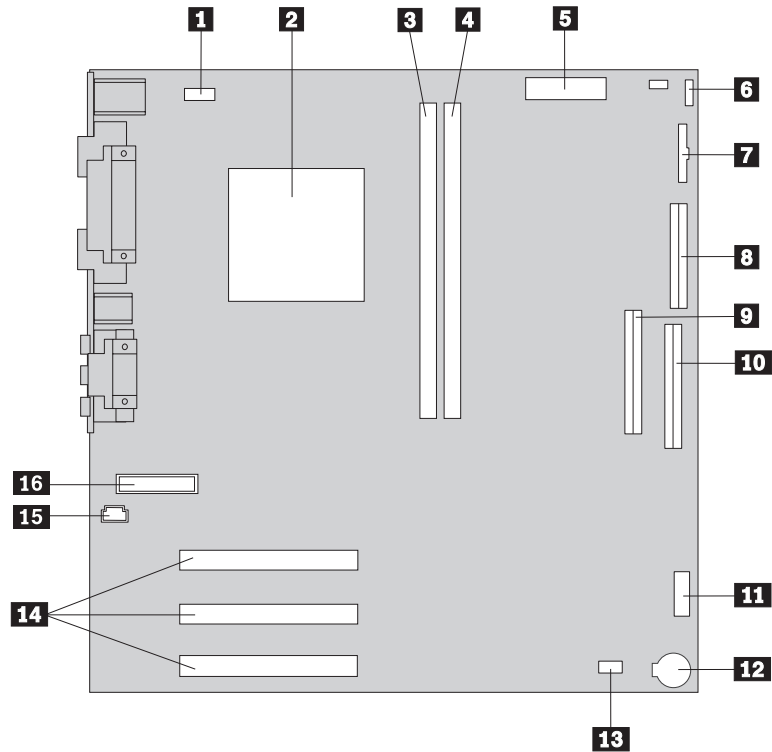

- | | |
|-----------------------------------|--|
| 1 Fan connector | 9 Secondary IDE connector |
| 2 Microprocessor | 10 Primary IDE connector |
| 3 DIMM connector 1 | 11 Front USB connector |
| 4 DIMM connector 2 | 12 Battery |
| 5 Power connector | 13 Virtual clear CMOS/BIOS recovery jumper (JP14) |
| 6 Hard disk LED connector | 14 PCI slots |
| 7 Power LED connector | 15 CD-ROM audio connector |
| 8 Diskette drive connector | 16 Front panel connector |

Installing memory

The computer has three connectors for installing dual in-line memory modules (DIMMs) that provide up to a maximum of 512 MB of system memory.

Installing and removing DIMMs

When installing DIMMs, the following rules apply:

- Fill each system memory connector sequentially, starting at DIMM 1
- Use 3.3 V, synchronous, 168-pin, unbuffered, 133 MHz nonparity synchronous dynamic random access memory (SDRAM)
- Use 64 MB, 128 MB, or 256 MB DIMMs in any combination
- DIMM heights of 38.1 mm (1.5 inches)

To install a DIMM:

1. Remove the cover. See “Removing the cover” on page 23.
2. You might have to remove an adapter to gain access to the DIMM slots. See “Installing and removing adapters” on page 27.

3. To locate the DIMM connectors. See “Identifying parts on the system board” on page 24.
4. Open the retaining clips.

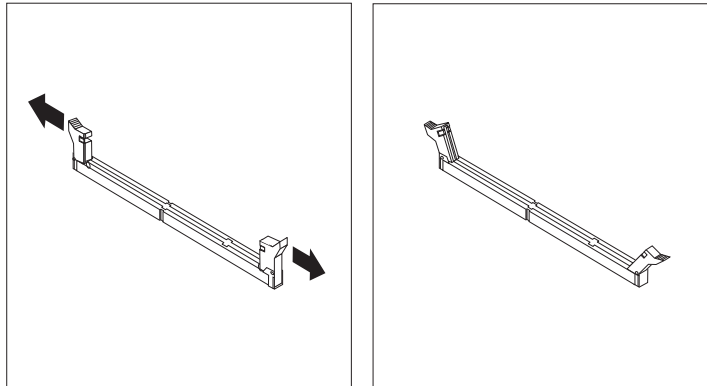

5. Make sure the notches in the DIMM align with the tabs on the connector. Push or insert the DIMM straight down into the connector until the retaining clips close.

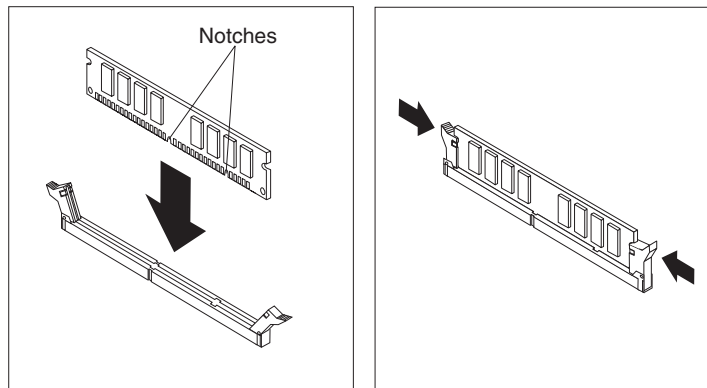

To remove a DIMM:

1. Remove the cover. See “Removing the cover” on page 23.
2. You might have to remove an adapter to gain access to the DIMM slots. See “Installing and removing adapters” on page 27.
3. To locate the DIMM connectors. See “Identifying parts on the system board” on page 24.
4. Open the retaining clips.
5. Lift the DIMM out of the DIMM slot.
6. Close the retaining clips.

What to do next:

- Replace any adapters that were removed.
- Replace the power supply.
- To work with another option, go to the appropriate section.
- To complete the installation, go to “Replacing the cover and connecting the cables” on page 33.

Installing and removing adapters

This section provides information and instructions for installing and removing adapters. The computer has three expansion slots for PCI adapters. You can install an adapter up to 228 mm (9 inches) long.

To install an adapter:

1. Remove the cover. See “Removing the cover” on page 23.
2. Remove the adapter slot cover for the appropriate expansion slot.

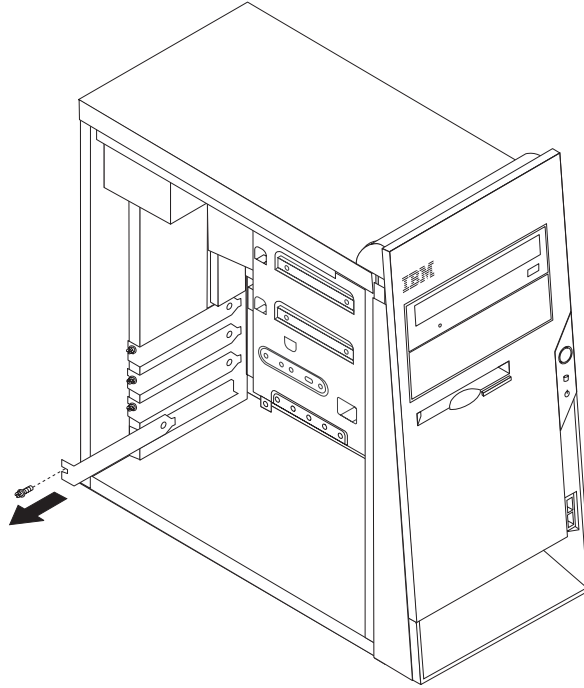

3. Remove the adapter from its static-protective package.

4. Install the adapter into the appropriate slot on the system board.
5. Secure the adapter with the screw as shown.

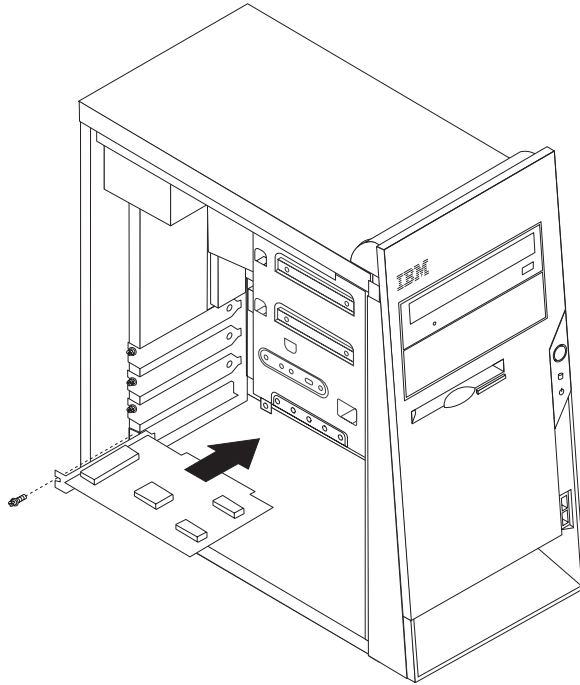

To remove an adapter:

1. Remove the cover. See "Removing the cover" on page 23.

2. Install the adapter into the appropriate slot on the system board.
3. Unscrew the adapter from the chassis.
4. Lift adapter out of PCI slot.

Installing and removing internal drives

This section provides information and instructions for installing and removing internal drives.

Internal drives are devices that the computer uses to read and store data. You can add drives to the computer to increase storage capacity and to enable the computer to read other types of media. Some of the different drives that are available are:

- Hard disk drives
- CD drives or DVD drives
- Removable media drives

Internal drives are installed in *bays*. In this book, the bays are referred to as bay 1, bay 2, and so on.

When installing an internal drive, it is important to note what type and size of drive that can be installed in each bay. Also, it is important to correctly connect the internal drive cables to the installed drive.

Drive specifications

Type 6029 computers come with the following IBM-installed drives:

- A CD-ROM, DVD-ROM, or CD-RW drive in bay 1 (some models)
- A 3.5-inch diskette disk drive in bay 3
- A 3.5-inch hard drive in bay 4

Any bay that does not have a drive installed has a static shield and bay panel installed.

The following illustration shows the locations of the drive bays.

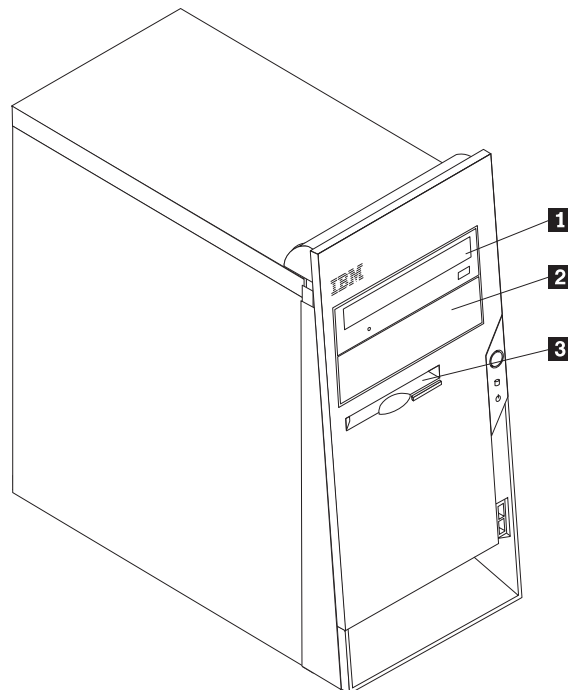

The following table describes some of the drives that can be installed in each bay and their height requirements.

1 Bay 1 - Maximum height: 43.0 mm (1.7 in.)	CD-ROM drive (preinstalled in some models) 5.25-inch hard disk drive
2 Bay 2 - Maximum height: 43.0 mm (1.7 in.)	5.25-inch hard disk drive 3.5-inch hard disk drive (requires a mounting bracket) CD-ROM drive DVD-ROM drive CD-RW drive
3 Bay 3 - Maximum height: 25.8 mm (1.0 in.)	3.5-inch diskette drive (preinstalled)
4 Bay 4 - Maximum height: 25.8 mm (1.0 in.)	3.5-inch hard disk drive

Notes:

1. Drives that are greater than 43.0 mm (1.7 in.) high cannot be installed.
2. Install removable media (tape or CD) drives in the accessible bays (bay 1 or 2).

Installing a drive

To install an internal drive, follow these steps:

1. Remove the cover. See “Removing the cover” on page 23.
2. If the computer has a CD drive or DVD drive, you might need to remove the signal and power cables from the drive.
3. Remove the bay panel from the drive bay by inserting a flat-blade screwdriver at the end and gently prying it loose.
4. Remove the metal shield from the drive bay by inserting a flat-blade screwdriver into one of the slots and gently prying it loose.

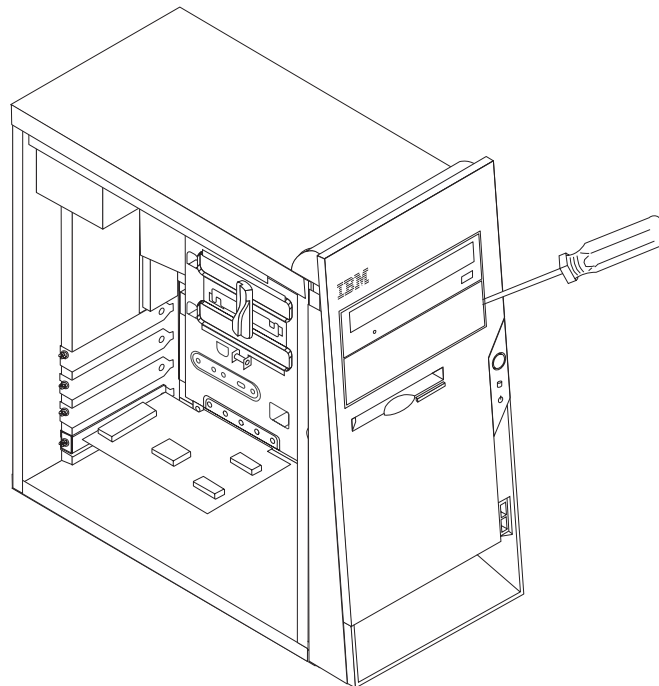

5. Make sure the drive that you are installing is set correctly as either a master or a slave device.
 - If it is the first CD drive or DVD drive, set it as a master device.

- If it is an additional CD drive or DVD drive, set it as a slave device.
- If it is a hard disk drive, set it as a slave device.

Refer to the documentation that comes with the drive for master/slave jumper information.

6. Install the drive into the bay. Close and latch the drive securing lock to secure the drive.
7. Each integrated drive electronics (IDE) drive requires two cables; a four-wire power cable that connects to the power supply and a signal cable that connects to the system board. For a CD-ROM drive, there might also be an audio cable.

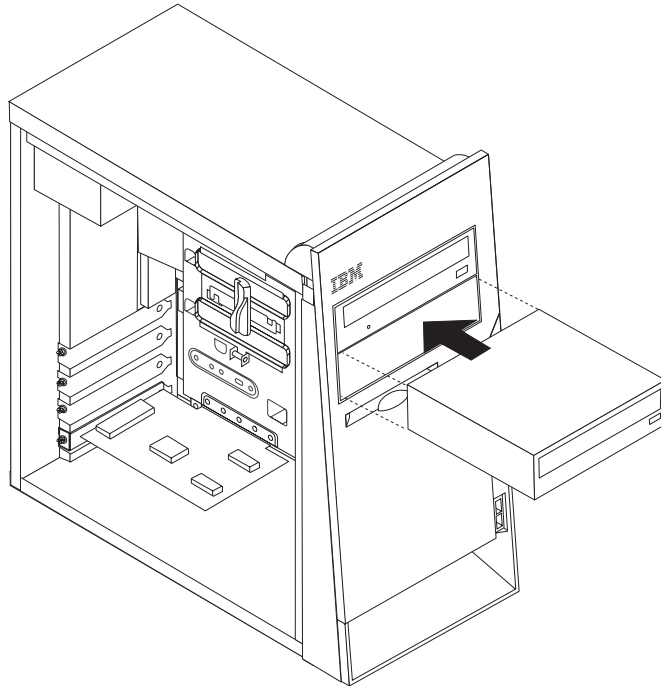

The steps to connect an IDE drive are different depending on the type of drive being connected. Use one of the following procedures for drive connection.

To connect the first IDE CD drive or DVD drive

1. Locate the three-connector signal cable that came with the computer or with the new drive.
2. Locate the secondary IDE connector on the system board. See “Identifying parts on the system board” on page 24.
3. Connect one end of the signal cable to the drive and the other to the secondary IDE connector on the system board. To reduce electronic noise, use the connectors at the end of the cable only.
4. Your computer has extra power connectors for additional drives. Connect a power connector to the drive.
5. If there is a CD-ROM audio cable, connect it to the drive and to the system board. See “Identifying parts on the system board” on page 24.

To connect an additional IDE CD drive or DVD drive

1. Locate the secondary IDE connector on the system board and the three-connector signal cable. See “Identifying parts on the system board” on page 24.
2. Connect the extra connector in the signal cable to the new CD drive or DVD drive.
3. The computer has extra power connectors for additional drives. Connect a power connector to the drive.

To connect an additional IDE hard disk drive

1. Locate the primary IDE connector on the system board. One end of the three-connector cable connects to the hard disk drive and the other connects to the system board. See “Identifying parts on the system board” on page 24.
2. Connect the extra connector in the signal cable to the new hard disk drive.
3. The computer has extra power connectors for additional drives. Connect a power connector to the drive.

Changing the battery

The computer has a special type of memory that maintains the date, time, and settings for built-in features, such as parallel-port assignments (configuration). A battery keeps this information active when the computer is turned off.

The battery normally requires no charging or maintenance throughout its life; however, no battery lasts forever. If the battery fails, the date, time, and configuration information (including passwords) are lost. An error message is displayed when the computer is turned on.

To change the battery:

1. Turn off the computer and all attached devices.
2. Unplug the power cord and remove the cover. See “Removing the cover” on page 23.
3. Locate the battery. See “Identifying parts on the system board” on page 24.
4. If necessary, remove any adapters that impede access to the battery. See “Installing and removing adapters” on page 27 for more information.
5. Remove the old battery.

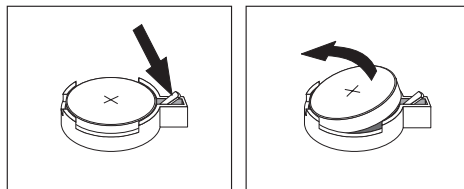

6. Install the new battery.

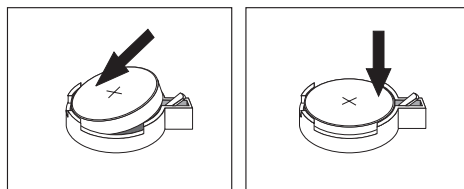

7. Replace any adapters that were removed to gain access to the battery. See “Installing and removing adapters” on page 27 for instructions for replacing adapters.
8. Replace the cover, and plug in the power cord. See “Replacing the cover and connecting the cables”.

Note: When the computer is turned on for the first time after battery replacement, an error message might be displayed. This is normal after replacing the battery.

9. Turn on the computer and all attached devices.
10. Use the Configuration/Setup Utility program to set the date and time and any passwords.

Replacing the cover and connecting the cables

After working with options, reinstall any removed parts, replace the cover, and reconnect any cables, including telephone lines and power cords. Also, depending on the option that is installed, you might need to confirm the updated information in the Configuration/Setup Utility program.

To replace the cover and connect cables to your computer:

1. Ensure that all components have been reassembled correctly and that no tools or loose screws are left inside your computer.
2. Clear any cables that might impede the replacement of the cover.

3. Position the cover on the chassis so that the guides on the top and bottom of the cover engage the chassis and push the cover to the closed position. Insert the screws that secure the cover.

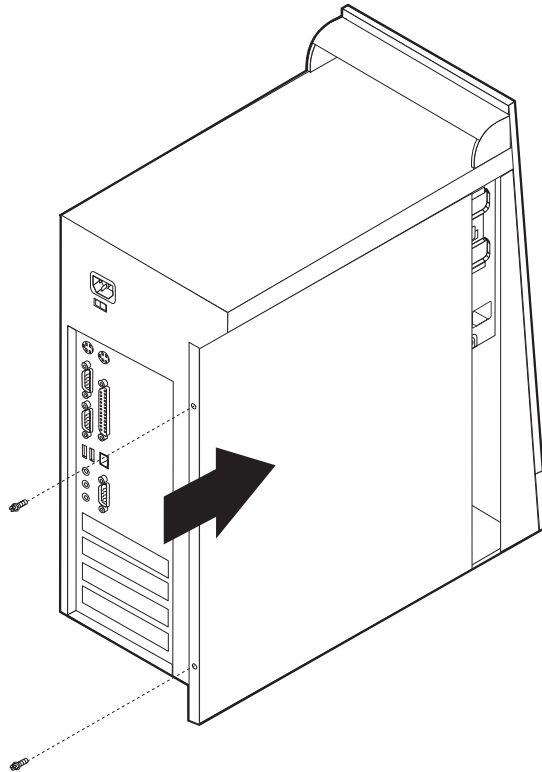

4. Reconnect the external cables and power cords to the computer. See “Installing external options” on page 19.
5. To update the configuration, see “Setup Utility program” on page 12.

Important:

When the power cord is first plugged in, the computer might appear to turn on for a few seconds and then turn off. This is a normal sequence to enable the computer to initialize.

Chapter 6. FRU Removals

These removals are to be done by trained service technicians only.

Important: Before you install or remove any option, read “Safety information” on page 93. These precautions and guidelines will help you work safely.

Replacing a microprocessor

To replace a microprocessor on any of the machine types, do the following:

1. Turn off the computer and peripheral devices and disconnect all external cables and power cords; then, remove the cover. See “Removing the cover” on page 23.
2. Press down and back on the silver tab holding the fansink in place to release it and pivot the retaining bar off of the fansink notches.
3. To remove the fansink from the processor, twist the fansink to break the seal formed by the thermal grease and remove.

Note: If the thermal grease seal cannot be broken, you may want to start up the system to heat the processor and loosen the thermal grease.

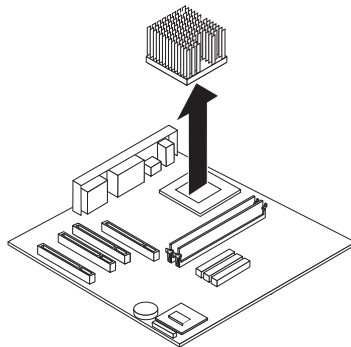

4. Pull out and lift up the processor socket lever arm upward to its maximum vertical position to release the processor.
5. Lift the processor out of the system board.

Note: When you install the new processor, make sure to reinstall the fansink to insure proper cooling.

Removals

For removals, it may be easier to lay the system on it's side.

Front bezel

To remove the front bezel, do the following:

1. Turn off the server and peripheral devices and disconnect all external cables and power cords.
2. Remove the cover. See “Removing the cover” on page 23

3. Push the bezel securing snaps out from inside the computer.

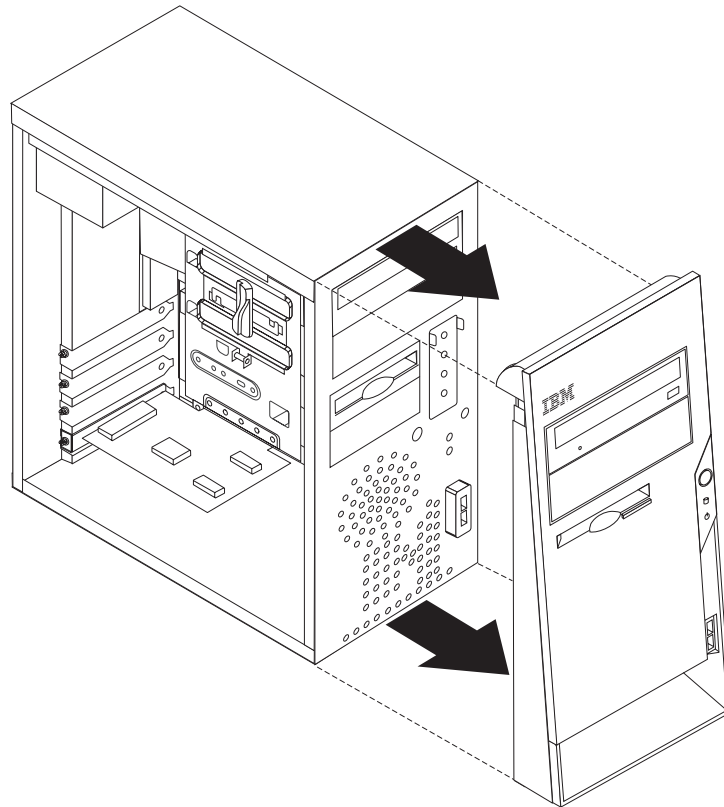

4. Pull the bezel off the computer.

Hard disk drive

To remove the hard disk drive, do the following:

1. Turn off the computer and peripheral devices and disconnect all external cables and power cords; then, remove the cover. See "Removing the cover" on page 23.
2. Remove the bezel. See "Front bezel" on page 35.
3. Disconnect all hard disk drive wires.

4. Remove the screws securing the hard disk drive.

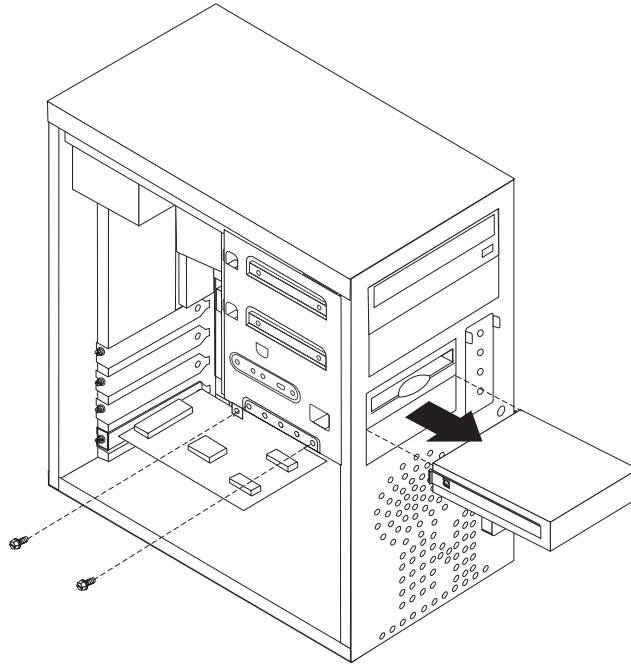

5. Remove the disk drive.

Note: When replacing the hard disk drive, make sure you obtain the proper Recovery CD to install after you install the new hard drive.

Power supply

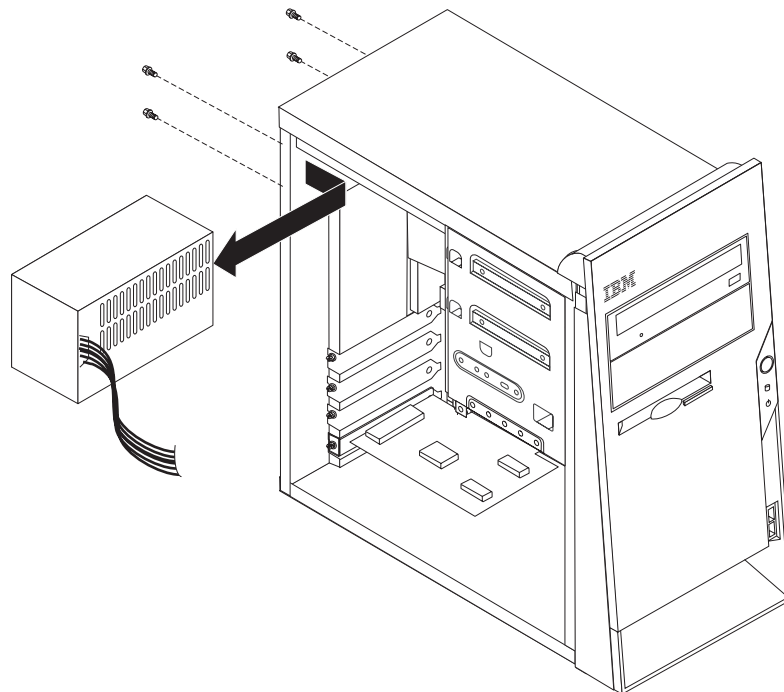

To remove the power supply, do the following:

1. Turn off the server and peripheral devices and disconnect all external cables and power cords; then, remove the cover. See “Removing the cover” on page 23.
2. Disconnect all power supply wires.
3. Remove the four screws holding the power supply to the back of the chassis.
4. Lift out the power supply.

System board

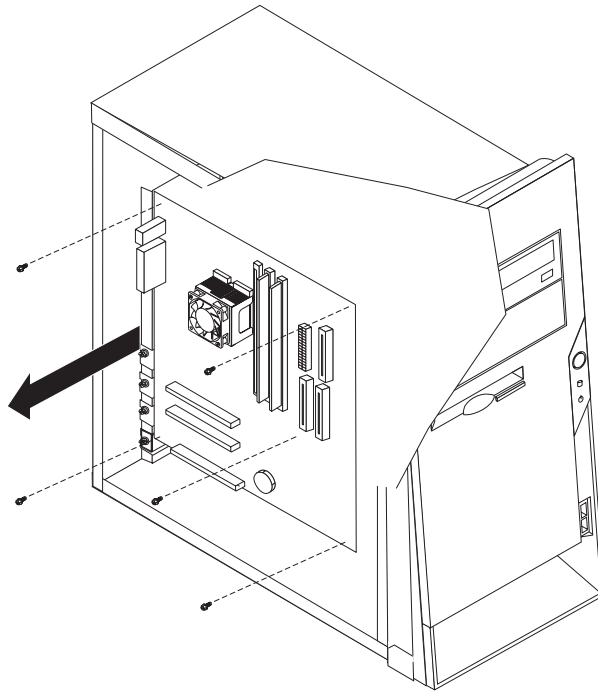

To remove the system board, do the following:

1. Turn off the server and peripheral devices and disconnect all external cables and power cords; then, remove the cover. See “Removing the cover” on page 23.
2. Disconnect all wires connected to the system board.
3. Remove the 5 screws that attach the system board to the chassis.
4. Lift out the system board.

Chapter 7. Symptom-to-FRU Index

The Symptom-to-FRU index lists error symptoms and possible causes. The most likely cause is listed first. Always begin with "General Checkout" on page 3. This index can also be used to help you decide which FRUs to have available when servicing a computer. If you are unable to correct the problem using this index, go to "Undetermined problems" on page 79.

Notes:

- If you have both an error message and an incorrect audio response, diagnose the error message first.
- If you cannot run the diagnostic tests or you get a diagnostic error code when running a test, but did receive a POST error message, diagnose the POST error message first.
- If you did not receive any error message, look for a description of your error symptoms in the first part of this index.
- Check the hard disk drive jumper settings before you replace a hard disk drive.

Hard disk drive boot error

A hard disk drive boot error (error codes 1962 and I999030X) can have the following causes.

Error	FRU/Action
The start-up drive is not in the boot sequence in configuration.	Check the configuration and ensure the start-up drive is in the boot sequence.
No operating system installed on the boot drive.	Install an operating system on the boot drive.
The boot sector on the start-up drive is corrupted.	The drive must be formatted, do the following: <ol style="list-style-type: none">1. Attempt to access and recover (back-up) the failing hard disk drive.2. Using the operating systems programs, format the hard disk drive.
The drive is defective.	Replace the hard disk drive.

Power Supply Errors

If the power-on indicator is not on, the power supply fan is not running, or the computer will not power-off, use the following procedures.

Check/Verify	FRU/Action
Check the following for proper installation. <ul style="list-style-type: none">• Power Cord• On/Off Switch connector• On/Off Switch Power Supply connector• System Board Power Supply connectors• Microprocessor(s) connection	Reseat
Check the power-on switch for continuity.	Power Cord

Check/Verify	FRU/Action
Check the power-on switch for continuity.	Power-on Switch

Diagnostic error codes

Refer to the following diagnostic error codes when using the diagnostic tests. See "Diagnostics" on page 11 for the specific type for information about the Diagnostic programs.

In the following index, X can represent any number.

Diagnostic Error Code	FRU/Action
000-000-XXX BIOS Test Passed	1. No action
000-002-XXX BIOS Timeout	1. Flash the system 2. System board
000-024-XXX BIOS Addressing test failure	1. Flash the system 2. System board
000-025-XXX BIOS Checksum Value error	1. Flash the system 2. Boot block 3. System board
000-026-XXX FLASH data error	1. Flash the system 2. Boot block 3. System board
000-027-XXX BIOS Configuration/Setup error	1. Run Setup 2. Flash the system 3. Boot block 4. System board
000-034-XXX BIOS Buffer Allocation failure	1. Reboot the system 2. Flash the system 3. Run memory test 4. System board
000-035-XXX BIOS Reset Condition detected	1. Flash the system 2. System board
000-036-XXX BIOS Register error	1. Flash the system 2. Boot block 3. System board
000-038-XXX BIOS Extension failure	1. Flash the system 2. Adapter card 3. System board
000-039-XXX BIOS DMI data error	1. Flash the system 2. System board
000-195-XXX BIOS Test aborted by user	1. Information 2. Re-start the test, if necessary
000-196-XXX BIOS test halt, error threshold exceeded	1. Press F3 to review the log file 2. Re-start the test to reset the log file

Diagnostic Error Code	FRU/Action
000-197-XXX BIOS test warning	<ol style="list-style-type: none"> 1. Make sure the component that is called out is connected and/or enabled 2. Re-run test 3. Component that is called out in warning statement 4. Component under test
000-198-XXX BIOS test aborted	<ol style="list-style-type: none"> 1. If a component is called out, make sure it is connected and/or enabled 2. Flash the system and re-test 3. Go to the "Undetermined problems" section
000-199-XXX BIOS test failed, cause unknown	<ol style="list-style-type: none"> 1. Go to the "Undetermined problems" section 2. Flash the system and re-test 3. Replace component under function test
000-250-XXX BIOS APM failure	<ol style="list-style-type: none"> 1. Flash the system 2. System board
000-270-XXX BIOS ACPI failure	<ol style="list-style-type: none"> 1. Flash the system 2. System board
001-000-XXX System Test Passed	<ol style="list-style-type: none"> 1. No action
001-00X-XXX System Error	<ol style="list-style-type: none"> 1. System board
001-01X-XXX System Error	<ol style="list-style-type: none"> 1. System board
001-024-XXX System Addressing test failure	<ol style="list-style-type: none"> 1. System board
001-025-XXX System Checksum Value error	<ol style="list-style-type: none"> 1. Flash the system 2. System board
001-026-XXX System FLASH data error	<ol style="list-style-type: none"> 1. Flash the system 2. System board
001-027-XXX System Configuration/Setup error	<ol style="list-style-type: none"> 1. Run Setup 2. Flash the system 3. System board
001-032-XXX System Device Controller failure	<ol style="list-style-type: none"> 1. System board
001-034-XXX System Device Buffer Allocation failure	<ol style="list-style-type: none"> 1. Reboot the system 2. Flash the system 3. Run memory test 4. System board
001-035-XXX System Device Reset condition detected	<ol style="list-style-type: none"> 1. System board
001-036-XXX System Register error	<ol style="list-style-type: none"> 1. System board

Diagnostic Error Code	FRU/Action
001-038-XXX System Extension failure	1. Adapter card 2. System board
001-039-XXX System DMI data structure error	1. Flash the system 2. System board
001-040-XXX System IRQ failure	1. Power-off/on system and re-test 2. System board
001-041-XXX System DMA failure	1. Power-off/on system and re-test 2. System board
001-195-XXX System Test aborted by user	1. Information 2. Re-start the test, if necessary
001-196-XXX System test halt, error threshold exceeded	1. Press F3 to review the log file 2. Re-start the test to reset the log file
001-197-XXX System test warning	1. Make sure the component that is called out is connected and/or enabled 2. Re-run test 3. Component that is called out in warning statement 4. Component under test
001-198-XXX System test aborted	1. If a component is called out, make sure it is connected and/or enabled 2. Flash the system and re-test 3. Go to the "Undetermined problems" section
001-199-XXX System test failed, cause unknown	1. Go to the "Undetermined problems" section 2. Flash the system and re-test 3. Replace component under function test
001-250-XXX System ECC error	1. System board
001-254-XXX 001-255-XXX 001-256-XXX 001-257-XXX System DMA error	1. System board
001-260-XXX 001-264-XXX System IRQ error	1. System board
001-268-XXX System IRQ1 failure	1. Device on IRQ1 2. System board
001-269-XXX System IRQ2 failure	1. Device on IRQ2 2. System board
001-270-XXX System IRQ3 failure	1. Device on IRQ3 2. System board

Diagnostic Error Code	FRU/Action
001-271-XXX System IRQ4 failure	1. Device on IRQ4 2. System board
001-272-XXX System IRQ5 failure	1. Device on IRQ5 2. System board
001-273-XXX System IRQ6 (diskette drive) failure	1. Diskette Cable 2. Diskette drive 3. System board
001-274-XXX System IRQ7 failure	1. Device on IRQ7 2. System board
001-275-XXX System IRQ8 failure	1. Device on IRQ8 2. System board
001-276-XXX System IRQ9 failure	1. Device on IRQ9 2. System board
001-277-XXX System IRQ10 failure	1. Device on IRQ10 2. System board
001-278-XXX System IRQ11 failure	1. Device on IRQ11 2. System board
001-279-XXX System IRQ12 failure	1. Device on IRQ12 2. System board
001-280-XXX System IRQ13 failure	1. Device on IRQ13 2. System board
001-281-XXX System IRQ14 (hard disk drive) failure	1. Hard disk drive cable 2. Hard disk drive 3. System board
001-282-XXX System IRQ15 failure	1. Device on IRQ15 2. System board
001-286-XXX 001-287-XXX 001-288-XXX System Timer failure	1. System board
001-292-XXX System CMOS RAM error	1. Run Setup and re-test 2. System board
001-293-XXX System CMOS Battery	1. Battery 2. System board
001-298-XXX System RTC date/time update failure	1. Flash the system 2. System board
001-299-XXX System RTC periodic interrupt failure	1. System board
001-300-XXX System RTC Alarm failure	1. System board

Diagnostic Error Code	FRU/Action
001-301-XXX System RTC Century byte error	<ol style="list-style-type: none"> 1. Flash the system 2. System board
005-000-XXX Video Test Passed	<ol style="list-style-type: none"> 1. No action
005-00X-XXX Video error	<ol style="list-style-type: none"> 1. Video card, if installed 2. System board
005-010-XXX 005-011-XXX 005-012-XXX 005-013-XXX Video Signal failure	<ol style="list-style-type: none"> 1. Video card, if installed 2. System board
005-016-XXX Video Simple Pattern test failure	<ol style="list-style-type: none"> 1. Video Ram 2. Video card, if installed 3. System board
005-024-XXX Video Addressing test failure	<ol style="list-style-type: none"> 1. Video card, if installed 2. System board
005-025-XXX Video Checksum Value error	<ol style="list-style-type: none"> 1. Video card, if installed 2. System board
005-027-XXX Video Configuration/Setup error	<ol style="list-style-type: none"> 1. Run Setup 2. Video drivers update 3. Video card, if installed 4. System board
005-031-XXX Video Device Cable failure	<ol style="list-style-type: none"> 1. Video cable 2. Monitor 3. Video card, if installed 4. System board
005-032-XXX Video Device Controller failure	<ol style="list-style-type: none"> 1. Video card, if installed 2. System board
005-036-XXX Video Register error	<ol style="list-style-type: none"> 1. Video card, if installed 2. System board
005-038-XXX System BIOS extension failure	<ol style="list-style-type: none"> 1. Video card, if installed 2. System board
005-040-XXX Video IRQ failure	<ol style="list-style-type: none"> 1. Video card, if installed 2. System board
005-195-XXX Video Test aborted by user	<ol style="list-style-type: none"> 1. Information 2. Re-start the test, if necessary
005-196-XXX Video test halt, error threshold exceeded	<ol style="list-style-type: none"> 1. Press F3 to review the log file 2. Re-start the test to reset the log file

Diagnostic Error Code	FRU/Action
005-197-XXX Video test warning	<ol style="list-style-type: none"> 1. Make sure the component that is called out is connected and/or enabled 2. Re-run test 3. Component that is called out in warning statement 4. Component under test
005-198-XXX Video test aborted	<ol style="list-style-type: none"> 1. If a component is called out, make sure it is connected and/or enabled 2. Flash the system and re-test 3. Go to the "Undetermined problems" section
005-199-XXX Video test failed, cause unknown	<ol style="list-style-type: none"> 1. Go to the "Undetermined problems" section 2. Flash the system and re-test 3. Replace component under function test
005-2XX-XXX 005-3XX-XXX Video subsystem error	<ol style="list-style-type: none"> 1. Video card, if installed 2. System board
006-000-XXX Diskette interface Test Passed	<ol style="list-style-type: none"> 1. No action
006-0XX-XXX Diskette interface error	<ol style="list-style-type: none"> 1. Diskette drive Cable 2. Diskette drive 3. System board
006-195-XXX Diskette interface Test aborted by user	<ol style="list-style-type: none"> 1. Information 2. Re-start the test, if necessary
006-196-XXX Diskette interface test halt, error threshold exceeded	<ol style="list-style-type: none"> 1. Press F3 to review the log file 2. Re-start the test to reset the log file
006-197-XXX Diskette interface test warning	<ol style="list-style-type: none"> 1. If a component is called out, make sure it is connected and/or enabled 2. Re-run test 3. Component that is called out in warning statement 4. Component under test
006-198-XXX Diskette interface test aborted	<ol style="list-style-type: none"> 1. If a component is called out, make sure it is connected and/or enabled 2. Flash the system and re-test 3. Go to the "Undetermined problems" section
006-199-XXX Diskette interface test failed, cause unknown	<ol style="list-style-type: none"> 1. Go to the "Undetermined problems" section 2. Flash the system and re-test 3. Replace component under function test
006-25X-XXX Diskette interface Error	<ol style="list-style-type: none"> 1. Diskette drive cable 2. Diskette drive 3. System board

Diagnostic Error Code	FRU/Action
011-000-XXX Serial port Interface Test Passed	1. No action
011-001-XXX Serial port Presence	1. Remove external serial device, if present 2. Run setup, enable port 3. System board
011-002-XXX 011-003-XXX Serial port Timeout/Parity error	1. System board
011-013-XXX 011-014-XXX Serial port Control Signal/Loopback test failure	1. System board
011-015-XXX Serial port External Loopback failure	1. Wrap plug 2. System board
011-027-XXX Serial port Configuration/Setup error	1. Run Setup, enable port 2. Flash the system 3. System board
011-03X-XXX 011-04X-XXX Serial port failure	1. System board
011-195-XXX Serial port Test aborted by user	1. Information 2. Re-start the test, if necessary
011-196-XXX Serial port test halt, error threshold exceeded	1. Press F3 to review the log file 2. Re-start the test to reset the log file
011-197-XXX Serial port test warning	1. Make sure the component that is called out is connected and/or enabled 2. Re-run test 3. Component that is called out in warning statement 4. Component under test
011-198-XXX Serial port test aborted	1. If a component is called out, make sure it is connected and/or enabled 2. Flash the system and re-test 3. Go to the "Undetermined problems" section
011-199-XXX Serial port test failed, cause unknown	1. Go to the "Undetermined problems" section 2. Flash the system and re-test 3. Replace component under function test
011-2XX-XXX Serial port signal failure	1. External serial device 2. System board
014-000-XXX Parallel port Interface Test Passed	1. No action

Diagnostic Error Code	FRU/Action
014-001-XXX Parallel port Presence	<ol style="list-style-type: none"> 1. Remove external parallel device, if present 2. Run setup, enable port 3. System board
014-002-XXX 014-003-XXX Parallel port Timeout/Parity error	<ol style="list-style-type: none"> 1. System board
014-013-XXX 014-014-XXX Parallel port Control Signal/Loopback test failure	<ol style="list-style-type: none"> 1. System board
014-015-XXX Parallel port External Loopback failure	<ol style="list-style-type: none"> 1. Wrap plug 2. System board
014-027-XXX Parallel port Configuration/Setup error	<ol style="list-style-type: none"> 1. Run Setup, enable port 2. Flash the system 3. System board
014-03X-XXX 014-04X-XXX Parallel port failure	<ol style="list-style-type: none"> 1. System board
014-195-XXX Parallel port Test aborted by user	<ol style="list-style-type: none"> 1. Information 2. Re-start the test, if necessary
014-196-XXX Parallel port test halt, error threshold exceeded	<ol style="list-style-type: none"> 1. Press F3 to review the log file 2. Re-start the test to reset the log file
014-197-XXX Parallel port test warning	<ol style="list-style-type: none"> 1. Make sure the component that is called out is connected and/or enabled 2. Re-run test 3. Component that is called out in warning statement 4. Component under test
014-198-XXX Parallel port test aborted	<ol style="list-style-type: none"> 1. If a component is called out, make sure it is connected and/or enabled 2. Flash the system and re-test 3. Go to the "Undetermined problems" section
014-199-XXX Parallel port test failed, cause unknown	<ol style="list-style-type: none"> 1. Go to the "Undetermined problems" section 2. Flash the system and re-test 3. Replace component under function test
014-2XX-XXX 014-3XX-XXX Parallel port failure	<ol style="list-style-type: none"> 1. External parallel device 2. System board
015-000-XXX USB port Interface Test Passed	<ol style="list-style-type: none"> 1. No action
015-001-XXX USB port Presence	<ol style="list-style-type: none"> 1. Remove USB device(s) and re-test 2. System board

Diagnostic Error Code	FRU/Action
015-002-XXX USB port Timeout	<ol style="list-style-type: none"> 1. Remove USB device(s) and re-test 2. System board
015-015-XXX USB port External Loopback failure	<ol style="list-style-type: none"> 1. Remove USB device(s) and re-test 2. System board
015-027-XXX USB port Configuration/Setup error	<ol style="list-style-type: none"> 1. Flash the system 2. System board
015-032-XXX USB port Device Controller failure	<ol style="list-style-type: none"> 1. System board
015-034-XXX USB port buffer allocation failure	<ol style="list-style-type: none"> 1. Reboot the system 2. Flash the system 3. Run memory test 4. System board
015-035-XXX USB port Reset condition detected	<ol style="list-style-type: none"> 1. Remove USB device(s) and re-test 2. System board
015-036-XXX USB port Register error	<ol style="list-style-type: none"> 1. System board
015-040-XXX USB port IRQ failure	<ol style="list-style-type: none"> 1. Run setup and check for conflicts 2. Flash the system 3. System board
015-195-XXX USB port Test aborted by user	<ol style="list-style-type: none"> 1. Information 2. Re-start the test, if necessary
015-196-XXX USB port test halt, error threshold exceeded	<ol style="list-style-type: none"> 1. Press F3 to review the log file 2. Re-start the test to reset the log file
015-197-XXX USB port test warning	<ol style="list-style-type: none"> 1. Make sure the component that is called out is connected and/or enabled 2. Re-run test 3. Component that is called out in warning statement 4. Component under test
015-198-XXX USB port test aborted	<ol style="list-style-type: none"> 1. If a component is called out, make sure it is connected and/or enabled 2. Flash the system and re-test 3. Go to the "Undetermined problems" section
015-199-XXX USB port test failed, cause unknown	<ol style="list-style-type: none"> 1. Go to the "Undetermined problems" section 2. Flash the system and re-test 3. Replace component under function test
018-000-XXX PCI Card Test Passed	<ol style="list-style-type: none"> 1. No action
018-0XX-XXX PCI Card Failure	<ol style="list-style-type: none"> 1. Riser card, if installed 2. System board

Diagnostic Error Code	FRU/Action
018-195-XXX PCI Card Test aborted by user	<ol style="list-style-type: none"> 1. PCI card 2. Information 3. Re-start the test, if necessary
018-196-XXX PCI Card test halt, error threshold exceeded	<ol style="list-style-type: none"> 1. Press F3 to review the log file 2. Re-start the test to reset the log file
018-197-XXX PCI Card test warning	<ol style="list-style-type: none"> 1. Make sure the component that is called out is connected and/or enabled 2. Re-run test 3. Component that is called out in warning statement 4. Component under test
018-198-XXX PCI Card test aborted	<ol style="list-style-type: none"> 1. Make sure the component that is called out is connected and/or enabled 2. Flash the system and re-test 3. Go to the "Undetermined problems" section
018-199-XXX PCI Card test failed, cause unknown	<ol style="list-style-type: none"> 1. Go to the "Undetermined problems" section 2. Flash the system and re-test 3. Replace component under function test
018-250-XXX PCI Card Services error	<ol style="list-style-type: none"> 1. PCI card 2. Riser card, if installed 3. System board
020-000-XXX PCI Interface Test Passed	<ol style="list-style-type: none"> 1. No action
020-0XX-XXX PCI Interface error	<ol style="list-style-type: none"> 1. PCI card 2. Riser card, if installed 3. System board
020-195-XXX PCI Test aborted by user	<ol style="list-style-type: none"> 1. Information 2. Re-start the test, if necessary
020-196-XXX PCI test halt, error threshold exceeded	<ol style="list-style-type: none"> 1. Press F3 to review the log file 2. Re-start the test to reset the log file
020-197-XXX PCI test warning	<ol style="list-style-type: none"> 1. Make sure the component that is called out is connected and/or enabled 2. Re-run test 3. Component that is called out in warning statement 4. Component under test
020-198-XXX PCI test aborted	<ol style="list-style-type: none"> 1. If a component is called out, make sure it is connected and/or enabled 2. Flash the system and re-test 3. Go to the "Undetermined problems" section

Diagnostic Error Code	FRU/Action
020-199-XXX PCI test failed, cause unknown	<ol style="list-style-type: none"> 1. Go to the "Undetermined problems" section 2. Flash the system and re-test 3. Replace component under function test
020-262-XXX PCI system error	<ol style="list-style-type: none"> 1. PCI card 2. Riser card, if installed 3. System board
025-000-XXX IDE interface Test Passed	<ol style="list-style-type: none"> 1. No action
025-00X-XXX 025-01X-XXX IDE interface failure	<ol style="list-style-type: none"> 1. IDE signal cable 2. Check power supply 3. IDE device 4. System board
025-027-XXX IDE interface Configuration/Setup error	<ol style="list-style-type: none"> 1. IDE signal cable 2. Flash the system 3. IDE device 4. System board
025-02X-XXX 025-03X-XXX 025-04X-XXX IDE Interface failure	<ol style="list-style-type: none"> 1. IDE signal cable 2. Check power supply 3. IDE device 4. System board
025-195-XXX IDE interface Test aborted by user	<ol style="list-style-type: none"> 1. Information 2. Re-start the test, if necessary
025-196-XXX IDE interface test halt, error threshold exceeded	<ol style="list-style-type: none"> 1. Press F3 to review the log file 2. Re-start the test to reset the log file
025-197-XXX IDE interface test warning	<ol style="list-style-type: none"> 1. Make sure the component that is called out is connected and/or enabled 2. Re-run test 3. Component that is called out in warning statement 4. Component under test
025-198-XXX IDE interface test aborted	<ol style="list-style-type: none"> 1. If a component is called out, make sure it is connected and/or enabled 2. Flash the system and re-test 3. Go to the "Undetermined problems" section
025-199-XXX IDE interface test failed, cause unknown	<ol style="list-style-type: none"> 1. Go to the "Undetermined problems" section 2. Flash the system and re-test 3. Replace component under function test
030-000-XXX SCSI interface Test Passed	<ol style="list-style-type: none"> 1. No action

Diagnostic Error Code	FRU/Action
030-00X-XXX 030-01X-XXX SCSI interface failure	<ol style="list-style-type: none"> 1. SCSI signal cable 2. Check power supply 3. SCSI device 4. SCSI adapter card, if installed 5. System board
030-027-XXX SCSI interface Configuration/Setup error	<ol style="list-style-type: none"> 1. SCSI signal cable 2. Flash the system 3. SCSI device 4. SCSI adapter card, if installed 5. System board
030-03X-XXX 030-04X-XXX SCSI interface error	<ol style="list-style-type: none"> 1. SCSI signal cable 2. Check power supply 3. SCSI device 4. SCSI adapter card, if installed 5. installed System board
030-195-XXX SCSI interface Test aborted by user	<ol style="list-style-type: none"> 1. Information 2. Re-start the test, if necessary
030-196-XXX SCSI interface test halt, error threshold exceeded	<ol style="list-style-type: none"> 1. Press F3 to review the log file 2. Re-start the test to reset the log file
030-197-XXX SCSI interface test warning	<ol style="list-style-type: none"> 1. Make sure the component that is called out is connected and/or enabled 2. Re-run test 3. Component that is called out in warning statement 4. Component under test
030-198-XXX SCSI interface test aborted	<ol style="list-style-type: none"> 1. If a component is called out, make sure it is connected and/or enabled 2. Flash the system and re-test 3. Go to the "Undetermined problems" section
030-199-XXX SCSI interface test failed, cause unknown	<ol style="list-style-type: none"> 1. Go to the "Undetermined problems" section 2. Flash the system and re-test 3. Replace component under function test
035-000-XXX RAID interface Test Passed	<ol style="list-style-type: none"> 1. No action
035-0XX-XXX RAID interface Failure	<ol style="list-style-type: none"> 1. RAID signal cable 2. RAID device 3. RAID adapter card, if installed 4. System board
035-195-XXX RAID interface Test aborted by user	<ol style="list-style-type: none"> 1. Information 2. Re-start the test, if necessary

Diagnostic Error Code	FRU/Action
035-196-XXX RAID interface test halt, error threshold exceeded	<ol style="list-style-type: none"> 1. Press F3 to review the log file 2. Re-start the test to reset the log file
035-197-XXX RAID interface test warning	<ol style="list-style-type: none"> 1. Make sure the component that is called out is connected and/or enabled 2. Re-run test 3. Component that is called out in warning statement 4. Component under test
035-198-XXX RAID interface test aborted	<ol style="list-style-type: none"> 1. If a component is called out, make sure it is connected and/or enabled 2. Flash the system and re-test 3. Go to the "Undetermined problems" section
035-199-XXX RAID interface test failed, cause unknown	<ol style="list-style-type: none"> 1. Go to the "Undetermined problems" section 2. Flash the system and re-test 3. Replace component under function test
071-000-XXX Audio port Interface Test Passed	<ol style="list-style-type: none"> 1. No action
071-00X-XXX 071-01X-XXX 071-02X-XXX Audio port error	<ol style="list-style-type: none"> 1. Run Setup 2. Flash the system 3. System board
071-03X-XXX Audio port failure	<ol style="list-style-type: none"> 1. Speakers 2. Microphone 3. Audio card, if installed 4. System board
071-04X-XXX Audio port failure	<ol style="list-style-type: none"> 1. Run Setup 2. Audio card, if installed 3. System board
071-195-XXX Audio port Test aborted by user	<ol style="list-style-type: none"> 1. Information 2. Re-start the test, if necessary
071-196-XXX Audio port test halt, error threshold exceeded	<ol style="list-style-type: none"> 1. Press F3 to review the log file 2. Re-start the test to reset the log file
071-197-XXX Audio port test warning	<ol style="list-style-type: none"> 1. Make sure the component that is called out is connected and/or enabled 2. Re-run test 3. Component that is called out in warning statement 4. Component under test
071-198-XXX Audio port test aborted	<ol style="list-style-type: none"> 1. If a component is called out, make sure it is connected and/or enabled 2. Flash the system and re-test 3. Go to the "Undetermined problems" section

Diagnostic Error Code	FRU/Action
071-199-XXX Audio port test failed, cause unknown	<ol style="list-style-type: none"> 1. Go to the "Undetermined problems" section 2. Flash the system and re-test 3. Replace component under function test
071-25X-XXX Audio port failure	<ol style="list-style-type: none"> 1. Speakers 2. Audio card, if installed 3. System board
080-000-XXX Game Port interface Test Passed	<ol style="list-style-type: none"> 1. No action
080-XXX-XXX Game Port interface Error	<ol style="list-style-type: none"> 1. Remove the game port device and re-test the system
080-195-XXX Game Port interface Test aborted by user	<ol style="list-style-type: none"> 1. Information 2. Re-start the test, if necessary
080-196-XXX Game Port interface test halt, error threshold exceeded	<ol style="list-style-type: none"> 1. Press F3 to review the log file 2. Re-start the test to reset the log file
080-197-XXX Game Port interface test warning	<ol style="list-style-type: none"> 1. Make sure the component that is called out is connected and/or enabled 2. Re-run test 3. Component that is called out in warning statement 4. Component under test
080-198-XXX Game Port interface test aborted	<ol style="list-style-type: none"> 1. If a component is called out, make sure it is connected and/or enabled 2. Flash the system and re-test 3. Go to the "Undetermined problems" section
080-199-XXX Game Port interface test failed, cause unknown	<ol style="list-style-type: none"> 1. Go to the "Undetermined problems" section 2. Flash the system and re-test 3. Replace component under function test
086-000-XXX Mouse Port interface Test Passed	<ol style="list-style-type: none"> 1. No action
086-001-XXX Mouse Port interface Presence	<ol style="list-style-type: none"> 1. Mouse 2. System board
086-032-XXX Mouse Port interface Device controller failure	<ol style="list-style-type: none"> 1. Mouse 2. System board
086-035-XXX Mouse Port interface Reset	<ol style="list-style-type: none"> 1. Mouse 2. System board
086-040-XXX Mouse Port interface IRQ failure	<ol style="list-style-type: none"> 1. Run Setup 2. Mouse 3. System board
086-195-XXX Mouse Port interface Test aborted by user	<ol style="list-style-type: none"> 1. Information 2. Re-start the test, if necessary

Diagnostic Error Code	FRU/Action
086-196-XXX Mouse Port interface test halt, error threshold exceeded	<ol style="list-style-type: none"> 1. Press F3 to review the log file 2. Re-start the test to reset the log file
086-197-XXX Mouse Port interface test warning	<ol style="list-style-type: none"> 1. Make sure the component that is called out is connected and/or enabled 2. Re-run test 3. Component that is called out in warning statement 4. Component under test
086-198-XXX Mouse Port interface test aborted	<ol style="list-style-type: none"> 1. If a component is called out, make sure it is connected and/or enabled 2. Flash the system and re-test 3. Go to the "Undetermined problems" section
086-199-XXX Mouse Port interface test failed, cause unknown	<ol style="list-style-type: none"> 1. Go to the "Undetermined problems" section 2. Flash the system and re-test 3. Replace component under function test
089-000-XXX Microprocessor Test Passed	<ol style="list-style-type: none"> 1. No action
089-XXX-XXX Microprocessor failure	<ol style="list-style-type: none"> 1. Microprocessor(s) 2. System board
089-195-XXX Microprocessor Test aborted by user	<ol style="list-style-type: none"> 1. Information 2. Re-start the test, if necessary
089-196-XXX Microprocessor test halt, error threshold exceeded	<ol style="list-style-type: none"> 1. Press F3 to review the log file 2. Re-start the test to reset the log file
089-197-XXX Microprocessor test warning	<ol style="list-style-type: none"> 1. Make sure the component that is called out is connected and/or enabled 2. Re-run test 3. Component that is called out in warning statement 4. Component under test
089-198-XXX Microprocessor test aborted	<ol style="list-style-type: none"> 1. Flash the system and re-test 2. Go to the "Undetermined problems" section
089-199-XXX Microprocessor test failed, cause unknown	<ol style="list-style-type: none"> 1. If a component is called out, make sure it is connected and/or enabled 2. Go to the "Undetermined problems" section 3. Flash the system and re-test 4. Replace component under function test
170-000-XXX Voltage Sensor(s) Test Passed	<ol style="list-style-type: none"> 1. No action
170-0XX-XXX Voltage Sensor(s) failure	<ol style="list-style-type: none"> 1. Flash system 2. System board

Diagnostic Error Code	FRU/Action
170-195-XXX Voltage Sensor(s) Test aborted by user	<ol style="list-style-type: none"> Information Re-start the test, if necessary
170-196-XXX Voltage Sensor(s) test halt, error threshold exceeded	<ol style="list-style-type: none"> Press F3 to review the log file Re-start the test to reset the log file
170-197-XXX Voltage Sensor(s) test warning	<ol style="list-style-type: none"> Make sure the component that is called out is connected and/or enabled Re-run test Component that is called out in warning statement Component under test
170-198-XXX Voltage Sensor(s) test aborted	<ol style="list-style-type: none"> If a component is called out, make sure it is connected and/or enabled Flash the system and re-test Go to the "Undetermined problems" section
170-199-XXX Voltage Sensor(s) test failed, cause unknown	<ol style="list-style-type: none"> Go to the "Undetermined problems" section Flash the system and re-test Replace component under function test
170-250-XXX 170-251-XXX Voltage Sensor(s) Voltage limit error	<ol style="list-style-type: none"> Power supply System board
170-254-XXX Voltage Sensor(s) Voltage Regulator Module error	<ol style="list-style-type: none"> Voltage Regulator Module (VRM) Microprocessor System board
175-000-XXX Thermal Sensor(s) Test Passed	<ol style="list-style-type: none"> No action
175-0XX-XXX Thermal Sensor(s) failure	<ol style="list-style-type: none"> Flash system System board
175-195-XXX Thermal Sensor(s) Test aborted by user	<ol style="list-style-type: none"> Information Re-start the test, if necessary
175-196-XXX Thermal Sensor(s) test halt, error threshold exceeded	<ol style="list-style-type: none"> Press F3 to review the log file Re-start the test to reset the log file
175-197-XXX Thermal Sensor(s) test warning	<ol style="list-style-type: none"> Make sure the component that is called out is connected and/or enabled Re-run test Component that is called out in warning statement Component under test
175-198-XXX Thermal Sensor(s) test aborted	<ol style="list-style-type: none"> If a component is called out, make sure it is connected and/or enabled Flash the system and re-test Go to "Undetermined problems" section

Diagnostic Error Code	FRU/Action
175-199-XXX Thermal Sensor(s) test failed, cause unknown	<ol style="list-style-type: none"> 1. Go to the "Undetermined problems" section 2. Flash the system and re-test 3. Replace component under function test
175-250-XXX 175-251-XXX Thermal Sensor(s) limit error	<ol style="list-style-type: none"> 1. Check fans 2. Check Power supply 3. Microprocessor 4. System board
185-000-XXX Asset Security Test Passed	<ol style="list-style-type: none"> 1. No action
185-XXX-XXX Asset Security failure	<ol style="list-style-type: none"> 1. Flash system 2. System board
185-278-XXX Asset Security Chassis Intrusion	<ol style="list-style-type: none"> 1. Assure Asset Security Enabled 2. C2 Cover Switch 3. System board
201-000-XXX System Memory Test Passed	<ol style="list-style-type: none"> 1. No action
201-XXX-XXX System Memory error	<ol style="list-style-type: none"> 1. Replace the memory module called out by the test 2. System board
202-000-XXX System Cache Test Passed	<ol style="list-style-type: none"> 1. No action
202-XXX-XXX System Cache error	<ol style="list-style-type: none"> 1. Cache, if removable 2. System board 3. Microprocessor
206-000-XXX Diskette Drive Test Passed	<ol style="list-style-type: none"> 1. No action
206-XXX-XXX Diskette Drive error	<ol style="list-style-type: none"> 1. Diskette Drive Cable 2. Check power supply voltages 3. Diskette drive 4. System board
215-000-XXX CD-ROM Drive Test Passed	<ol style="list-style-type: none"> 1. No action
215-XXX-XXX CD-ROM Drive error	<ol style="list-style-type: none"> 1. CD-ROM Drive Cable 2. Check power supply voltages 3. CD-ROM drive 4. System board
217-000-XXX Hard Disk Drive Test Passed	<ol style="list-style-type: none"> 1. No action
217-25X-XXX 217-26X-XXX Hard Disk Drive (IDE) error	<ol style="list-style-type: none"> 1. Hard Disk Drive Cable 2. Check power supply voltages 3. Hard Disk drive (IDE) 4. System board

Diagnostic Error Code	FRU/Action
217-28X-XXX 217-29X-XXX Hard Disk Drive (SCSI) error	<ol style="list-style-type: none"> 1. Hard Disk Drive Cable 2. Check power supply voltages 3. Hard Disk drive (SCSI) 4. SCSI adapter card 5. System board
220-000-XXX Hi-Capacity Cartridge Drive Test Passed	<ol style="list-style-type: none"> 1. No action
220-XXX-XXX Hi-Capacity Cartridge Drive error	<ol style="list-style-type: none"> 1. Remove the Hi-Capacity Cartridge Drive and re-test the system
301-XXX-XXX Keyboard error	<ol style="list-style-type: none"> 1. Keyboard 2. Check and test mouse 3. System board
301-000-XXX Keyboard Test Passed	<ol style="list-style-type: none"> 1. No action
302-000-XXX Mouse Test Passed	<ol style="list-style-type: none"> 1. No action
302-XXX-XXX Mouse error	<ol style="list-style-type: none"> 1. Mouse 2. Check and test Keyboard 3. System board
303-000-XXX Joystick Test Passed	<ol style="list-style-type: none"> 1. No action
303-XXX-XXX Joystick error	<ol style="list-style-type: none"> 1. Remove the Joystick and re-test the system
305-000-XXX Monitor DDC Test Passed	<ol style="list-style-type: none"> 1. No action
305-250-XXX Monitor DDC self test failure	<ol style="list-style-type: none"> 1. Run Setup to enable DDC 2. Cable 3. Monitor 4. Video card 5. System board
415-000-XXX Modem Test Passed	<ol style="list-style-type: none"> 1. No action
415-XXX-XXX Modem error	<ol style="list-style-type: none"> 1. Remove the Modem and re-test the system

Beep symptoms

Beep symptoms are short tones or a series of short tones separated by pauses (intervals without sound). See the following examples.

Beeps	Description
1-2-X	<ul style="list-style-type: none"> • One beep • A pause (or break) • Two beeps • A pause (or break) • Any number of breaks
4	Four continuous beeps

Use the following table to diagnose beep symptoms.

Beep Symptom	FRU/Action
1-1-3 CMOS read-write error	<ol style="list-style-type: none"> 1. Run Setup 2. System Board
1-2-2-3 ROM BIOS check error	1. System Board
1-2-1 Programmable Interval Timer failed	1. System Board
1-2-2 DMA Initialization failed	1. System Board
1-2-3 DMA page register write/read failed	1. System Board
1-2-4 RAM refresh verification failed	<ol style="list-style-type: none"> 1. DIMM 2. System Board
1-3-3-1 1st 64K RAM test failed	<ol style="list-style-type: none"> 1. DIMM 2. System Board
1-3-2 1st 64K RAM parity test failed	<ol style="list-style-type: none"> 1. DIMM 2. Processor 3. System Board
2-2-3-1 Interrupt vector loading test failed	1. System Board
2-1-1 Secondary DMA register failed	1. System Board
2-1-2 Primary DMA register failed	1. System Board
2-1-3 Primary interrupt mask register failed	1. System Board
2-1-4 Secondary interrupt mask register failed	1. System Board
2-2-1 Interrupt vector loading failed	1. System Board
1-3-1-3 Keyboard controller failed	<ol style="list-style-type: none"> 1. System Board 2. Keyboard
2-2-3 CMOS power failure and checksum checks failed	<ol style="list-style-type: none"> 1. Battery 2. System Board

Beep Symptom	FRU/Action
2-2-4 CMOS configuration info validation failed	1. Battery 2. System Board
2-3-1 Screen initialization failed	1. Jumper on J28 2. System Board
2-3-2 Screen memory failed	1. System Board
2-3-3 Screen retrace failed	1. System Board
1-2 Search for video ROM failed	1. System Board
All other beep code sequences	1. System Board
Continuous beep	1. System Board
Repeating short beeps	1. Keyboard stuck key 2. Keyboard Cable 3. System Board

No-beep symptoms

Symptom/Error	FRU/Action
No beep during POST but computer works correctly.	1. System Board
No beep during POST.	1. See “Undetermined problems” on page 79. 2. System Board 3. Memory Module 4. Any Adapter or Device 5. Riser Card 6. Power Cord 7. Power Supply

POST error codes

Each time you power-on the system, it performs a series of tests that check the operation of the system and some options. This series of tests is called the *Power-On Self-Test*, or *POST*. POST does the following operations.

- Checks some basic system-board operations
- Checks the memory operation
- Starts the video operation
- Verifies that the diskette drive is working
- Verifies that the hard disk drive is working

If the POST finishes without detecting any problems, a single beep sounds and the first screen of the operating system or application program appears.

Note:

Type 6029 computers default to come up quiet (no beep and no memory count and checkpoint code display) when no errors are detected by POST.

To enable beep and memory count and checkpoint code display when a successful POST occurs, do the following:

1. Select **Start Options** in the Configuration/Setup Utility program (see “Setup Utility program” on page 12).
2. Set **Power-On Self-Test** to **Enhanced**.

If the POST detects a problem, an error message appears on the screen. A single problem can cause several error messages to appear. When you correct the cause of the first error message, the other error messages probably will not appear on the screen the next time you turn on the system.

In the following index, *X* can represent any number.

POST Error Code	FRU/Action
000 SCSI Adapter not enabled	1. Verify adapter device and Bus Master fields are enabled in PCI configuration program. See documentation shipped with computer.
02X	1. SCSI Adapter
08X Check SCSI terminator installation.	1. SCSI Cable 2. SCSI Terminator 3. SCSI Device 4. SCSI Adapter
101 System board interrupt failure	1. System Board
102 System board timer error	1. System Board
106	1. System Board
110 System board memory parity error	1. Memory Module 2. System Board

POST Error Code	FRU/Action
111 I/O channel parity error	<ol style="list-style-type: none"> Reseat adapters Any adapter Riser card System Board
114 Adapter ROM error	<ol style="list-style-type: none"> Adapter Memory System Board Riser card
129 Internal cache test error	<ol style="list-style-type: none"> Processor L2 Cache Memory System Board
135 Fan failure	<ol style="list-style-type: none"> Fan System board
151 System board failure	<ol style="list-style-type: none"> System Board
161 Bad CMOS battery	<ol style="list-style-type: none"> Run Setup CMOS Backup Battery (see "Safety information" on page 93) System Board
162 Configuration mismatch	<ol style="list-style-type: none"> Run Setup and verify Configuration Had a device been added, removed, changed location? If not, suspect that device. Power-on external devices first, then power-on computer CMOS Backup Battery (see "Safety information" on page 93) System Board System Board
163 Date and Time Incorrect	<ol style="list-style-type: none"> Time and Date Set CMOS Backup Battery (see "Safety information" on page 93) System Board
164 Memory Size Error	<ol style="list-style-type: none"> Run Setup. Check System Summary menu for memory size change. (See "Setup Utility program" on page 12.) Run the Extended Memory Diagnostic tests
166 Boot Block Check Sum Error	<ol style="list-style-type: none"> Run Flash Recovery using Boot Block. See "Flash recovery boot block jumper" on page 90. System Board
167 No Processor BIOS Update Found	<ol style="list-style-type: none"> Run Setup. Check Stepping level for the BIOS level needed, then perform the flash update. Processor

POST Error Code	FRU/Action
168 Alert on LAN error	<ol style="list-style-type: none"> 1. Run Setup. Check to see that Ethernet and Alert on LAN are enabled. 2. System Board
17X, 18X	<ol style="list-style-type: none"> 1. C2 Security
175 Primary Copy of Secure Data is damaged	<ol style="list-style-type: none"> 1. Run Configuration. See "Setup Utility program" on page 12. 2. System Board
176 The System has been tampered with	<ol style="list-style-type: none"> 1. Covers were removed from the computer
177 Corrupted Administrator Password	<ol style="list-style-type: none"> 1. System Board
178	<ol style="list-style-type: none"> 1. System Board
179 Boot Integrity Services Segment Error	<ol style="list-style-type: none"> 1. System Board
183	<ol style="list-style-type: none"> 1. Enter the administrator password
184 Asset Control Antenna not detected	<ol style="list-style-type: none"> 1. Make sure Asset Care and Asset ID are enabled in Configuration/Setup 2. RFID Antenna 3. System Board
185 Corrupted boot sequence	<ol style="list-style-type: none"> 1. Set configuration and reinstall the boot sequence
186 Security Hardware Control Logic Error	<ol style="list-style-type: none"> 1. System Board
187	<ol style="list-style-type: none"> 1. Clear Administration password 2. System Board
189	<ol style="list-style-type: none"> 1. More than three password attempts were made to access the computer
190 System Security: Invalid Remote Change Requested	<ol style="list-style-type: none"> 1. System Board
191 System Security: IBM Embedded Security Hardware Reset	<ol style="list-style-type: none"> 1. System Board
193 System Security: IBM Embedded Security Hardware Removed	<ol style="list-style-type: none"> 1. System Board
194 System Security: Asset ID Antenna has been Removed	<ol style="list-style-type: none"> 1. System Board
195 System Security: Asset ID Antenna has been Installed	<ol style="list-style-type: none"> 1. System Board
196 System Tampered Cleared	<ol style="list-style-type: none"> 1. System Board
1XX Not listed above	<ol style="list-style-type: none"> 1. System Board
201, 20X Memory data error	<ol style="list-style-type: none"> 1. Run Enhanced Diagnostics Memory Test 2. Memory Module 3. System Board

POST Error Code	FRU/Action
225	1. Unsupported Memory
229 External cache test error	1. L2 Cache Memory 2. System Board
262 POST detected a base memory or extended memory type error	1. Run Setup. Check System Summary menu for memory. (See "Setup Utility program" on page 12.) 2. Run the Extended Memory Diagnostic tests.
301 Keyboard Error	1. Keyboard 2. Keyboard Cable 3. System Board
303 With an 8603 error	1. Mouse 2. Keyboard 3. Keyboard Cable 4. System Board
303 With no 8603 error	1. Keyboard 2. Keyboard Cable 3. System Board
3XX Not listed above	1. Keyboard 2. Keyboard Cable 3. System Board
5XX	1. Video Adapter (if installed) 2. System Board
601	1. Diskette Drive A 2. Diskette Drive Cable 3. System Board 4. Riser card
602	1. Bad Diskette? 2. Verify Diskette and retry
604 And able to run diagnostics	1. Run Setup and verify diskette configuration settings 2. Diskette Drive A/B 3. Diskette Drive Cable 4. System Board 5. Riser card
605 POST cannot unlock the diskette drive	1. Diskette Drive 2. Diskette Drive Cable 3. System Board 4. Riser card
662 Configuration Change has occurred	1. Diskette drive configuration error or wrong diskette drive type; run Setup Configuration

POST Error Code	FRU/Action
6XX Not listed above	<ol style="list-style-type: none"> 1. Diskette Drive 2. System Board 3. Riser card 4. External Drive Adapter 5. Diskette Drive Cable 6. Power Supply
762 Math coprocessor configuration error	<ol style="list-style-type: none"> 1. Run Setup 2. Processor 3. System Board
7XX Not listed above	<ol style="list-style-type: none"> 1. Processor 2. System Board
962 Parallel port configuration error	<ol style="list-style-type: none"> 1. Run Configuration 2. Parallel Adapter (if installed) 3. System Board
9XX	<ol style="list-style-type: none"> 1. Printer 2. System Board
1047	<ol style="list-style-type: none"> 1. 16-Bit AT™ Fast SCSI Adapter
107X Check SCSI terminator installation	<ol style="list-style-type: none"> 1. Check SCSI terminator installation 2. SCSI Cable 3. SCSI Terminator 4. SCSI Device 5. SCSI Adapter
1101 Serial connector error, possible system board failure	<ol style="list-style-type: none"> 1. Run Enhanced Diagnostics
1101, 1102, 1106, 1108, 1109	<ol style="list-style-type: none"> 1. System Board 2. Any Serial Device
1107	<ol style="list-style-type: none"> 1. Communications Cable 2. System Board
1102 Card selected feedback error	<ol style="list-style-type: none"> 1. Run Enhanced Diagnostics
1103 Port fails register check	<ol style="list-style-type: none"> 1. Run Enhanced Diagnostics 2. System Board
1106 Serial option cannot be turned off	<ol style="list-style-type: none"> 1. Run Enhanced Diagnostics 2. System Board
1107	<ol style="list-style-type: none"> 1. Serial Device Cable 2. System Board
1110 Register test failed	<ol style="list-style-type: none"> 1. Run Enhanced Diagnostics 2. System Board
1116 Interrupt error	<ol style="list-style-type: none"> 1. Run Enhanced Diagnostics

POST Error Code	FRU/Action
1117 Failed baud rate test	1. Run Enhanced Diagnostics
1162 Serial port configuration error	1. Run Configuration 2. Serial Adapter (if installed) 3. System Board
11XX Not listed above	1. System Board
1201	1. System Board 2. Any Serial Device
1202, 1206, 1208, 1209, 12XX	1. Dual Async Adapter/A 2. System Board 3. Any Serial Device
1207	1. Communications Cable 2. Dual Async Adapter/A
13XX	1. Game Adapter
1402 Printer not ready	Information only
1403 No paper error, or interrupt failure	Information only
1404 System board timeout failure	1. Run Enhanced Diagnostics
1405 Parallel adapter error	1. Run Enhanced Diagnostics
1406 Presence test error	1. Run Enhanced Diagnostics
14XX Not listed above. Check printer before replacing system board	1. Printer 2. System Board
15XX	1. SDLC Adapter
1692 Boot sequence error	1. Run FDISK to ensure at least one active partition is set active
16XX	1. 36/38 Workstation Adapter
1762 Hard disk drive configuration error	1. Run Configuration. (See "Setup Utility program" on page 12.)
1780 (Disk Drive 0) 1781 (Disk Drive 1) 1782 (Disk Drive 2) 1783 (Disk Drive 3)	1. Hard Disk Drive 2. System Board 3. Riser card 4. Hard Disk Cable 5. Power Supply

POST Error Code	FRU/Action
1800 PCI/PnP Error! No Hardware Interrupt Available	<ol style="list-style-type: none"> 1. Run Setup and verify PCI/ISA configuration settings. 2. If necessary, set ISA adapters to <i>Not available</i> to allow PCI adapters to properly configure. 3. Remove any suspect ISA adapters. 4. Rerun diagnostics. 5. PCI Adapter
1801 PCI/PnP Error! No Space Available to Shadow ROM	<ol style="list-style-type: none"> 1. Run Setup and verify PCI/ISA configuration settings. 2. If necessary, set ISA adapters to <i>Not available</i> to allow PCI adapters to properly configure. 3. Remove any suspect ISA adapters. 4. Rerun diagnostics. 5. PCI Adapter
1802 PCI/PnP Error! Not Enough I/O Space Available	<ol style="list-style-type: none"> 1. Run Setup and verify PCI/ISA configuration settings. 2. If necessary, set ISA adapters to <i>Not available</i> to allow PCI adapters to properly configure. 3. Remove any suspect ISA adapters. 4. Rerun diagnostics. 5. PCI Adapter
1803 PCI/PnP Error! Not Enough Memory Space Available	<ol style="list-style-type: none"> 1. Run Setup and verify PCI/ISA configuration settings. 2. If necessary, set ISA adapters to <i>Not available</i> to allow PCI adapters to properly configure. 3. Remove any suspect ISA adapters. 4. Rerun diagnostics. 5. PCI Adapter
1804 PCI/PnP Error! Not Enough Real Memory Space Available	<ol style="list-style-type: none"> 1. Run Setup and verify PCI/ISA configuration settings. 2. If necessary, set ISA adapters to <i>Not available</i> to allow PCI adapters to properly configure. 3. Remove any suspect ISA adapters. 4. Rerun diagnostics. 5. PCI Adapter
1805 PCI/PnP Error! Adapter ROM Checksum Error	<ol style="list-style-type: none"> 1. Run Setup and verify PCI/ISA configuration settings. 2. If necessary, set ISA adapters to <i>Not available</i> to allow PCI adapters to properly configure. 3. Remove any suspect ISA adapters. 4. Rerun diagnostics. 5. PCI Adapter

POST Error Code	FRU/Action
180X, 188X PCI configuration or resource error	<ol style="list-style-type: none"> 1. Run Setup and verify PCI/ISA configuration settings. 2. If necessary, set ISA adapters to <i>Not available</i> to allow PCI adapters to properly configure. 3. Remove any suspect ISA adapters. 4. Rerun diagnostics. 5. PCI Adapter
1962 No operating system found	<ol style="list-style-type: none"> 1. Press F1 to repeat boot sequence.
209X	<ol style="list-style-type: none"> 1. Diskette Drive 2. Diskette Cable
20XX Not listed above	<ol style="list-style-type: none"> 1. BSC Adapter
21XX	<ol style="list-style-type: none"> 1. SCSI Device 2. 16-bit AT Fast SCSIU adapter 3. Alternate BSC adapter
2401, 2402 If screen colors change	<ol style="list-style-type: none"> 1. Display
2401, 2402 If screen colors are OK	<ol style="list-style-type: none"> 1. System Board 2. Display
2409	<ol style="list-style-type: none"> 1. Display
2410	<ol style="list-style-type: none"> 1. System Board 2. Display
2462 Video memory configuration error	<ol style="list-style-type: none"> 1. Check cable connections 2. Run Setup and verify video configuration settings 3. Video Memory Modules 4. Video Adapter (if installed) 5. System Board
4611, 4630	<ol style="list-style-type: none"> 1. Multiport/2 Interface Board 2. Multiport/2 Adapter
4612, 4613, 4640, 4641	<ol style="list-style-type: none"> 1. Memory Module Package 2. Multiport/2 Adapter
4650	<ol style="list-style-type: none"> 1. Multiport/2 Interface Cable
46XX Not listed above	<ol style="list-style-type: none"> 1. Multiport/2 Adapter 2. Multiport/2 Interface Board 3. Memory Module
5600	<ol style="list-style-type: none"> 1. Financial System Controller Adapter

POST Error Code	FRU/Action
5962 An IDE device (other than hard drive) configuration error	<ol style="list-style-type: none"> 1. Run Configuration 2. CD-ROM Drive 3. CD-ROM Adapter 4. Zip or other ATAPI device 5. System Board 6. Riser card
62XX	<ol style="list-style-type: none"> 1. 1st Store Loop Adapter 2. Adapter Cable
63XX	<ol style="list-style-type: none"> 1. 2nd Store Loop Adapter 2. Adapter Cable
64XX	<ol style="list-style-type: none"> 1. Network Adapter
71XX	<ol style="list-style-type: none"> 1. Voice Adapter
74XX	<ol style="list-style-type: none"> 1. Video Adapter (if installed)
76XX	<ol style="list-style-type: none"> 1. Page Printer Adapter
78XX	<ol style="list-style-type: none"> 1. High Speed Adapter
79XX	<ol style="list-style-type: none"> 1. 3117 Adapter
80XX	<ol style="list-style-type: none"> 1. PCMCIA Adapter
84XX	<ol style="list-style-type: none"> 1. Speech Adapter 2. Speech Control Assembly.
8601, 8602	<ol style="list-style-type: none"> 1. Pointing Device (Mouse) 2. System Board
8603, 8604 Pointing Device Error	<ol style="list-style-type: none"> 1. System Board 2. Pointing Device (Mouse)
86XX Not listed above	<ol style="list-style-type: none"> 1. Mouse 2. System Board
89XX	<ol style="list-style-type: none"> 1. PC Music Adapter 2. MIDI Adapter Unit
91XX	<ol style="list-style-type: none"> 1. Optical Drive 2. Adapter
96XX	<ol style="list-style-type: none"> 1. SCSI Adapter 2. Any SCSI Device 3. System Board 4. Riser card
10101, 10102, 10104, 10105, 10106, 10107, 10108, 10109, 10111, 10112, 10113, 10114, 10115, 10116	<ol style="list-style-type: none"> 1. Have customer verify correct operating system device drivers are installed and operational. 2. Modem

POST Error Code	FRU/Action
10103, 10110, 101171	<ol style="list-style-type: none"> 1. System Board 2. Data/Fax Modem 3. Riser card
10117 Not listed above	<ol style="list-style-type: none"> 1. Check system speaker 2. Check PSTN cable 3. External DAA (if installed) 4. Modem
10118	<ol style="list-style-type: none"> 1. Run Diagnostics and verify the correct operation of the modem slot 2. Modem
10119	<ol style="list-style-type: none"> 1. Diagnostics detected a non-IBM modem 2. Modem
10120	<ol style="list-style-type: none"> 1. Check PSTN Cable 2. External DAA (if installed) 3. Modem
10132, 10133, 10134, 10135, 10136, 10137, 10138, 10139, 10140, 10141, 10142, 10143, 10144, 10145, 10146, 10147, 10148, 10149, 10150, 10151, 10152	<ol style="list-style-type: none"> 1. Modem
10153	<ol style="list-style-type: none"> 1. Data/Fax Modem 2. System Board 3. Riser card
101XX Not listed above	<ol style="list-style-type: none"> 1. Modem Adapter/A 2. Data/Fax Modem 3. System Board 4. Riser card
10450, 10451, 10490, 10491, 10492, 10499 Read/write error	<ol style="list-style-type: none"> 1. Run Enhanced Diagnostics 2. Hard Disk Drive 3. System Board 4. Riser card
10452 Seek test error	<ol style="list-style-type: none"> 1. Run Enhanced Diagnostics
10453 Wrong drive type?	Information only
10454 Sector buffer test error	<ol style="list-style-type: none"> 1. Run Enhanced Diagnostics
10455, 10456 Controller error	<ol style="list-style-type: none"> 1. Run Enhanced Diagnostics
10459 Drive diagnostic command error	Information only

POST Error Code	FRU/Action
10461 Drive format error	1. Run Enhanced Diagnostics
10462 Controller seek error	1. Run Enhanced Diagnostics
10464 Hard Drive read error	1. Run Enhanced Diagnostics
10467 Drive non-fatal seek error	1. Run Enhanced Diagnostics
10468 Drive fatal seek error	1. Run Enhanced Diagnostics
10469 Drive soft error count exceeded	1. Run Enhanced Diagnostics
10470, 10471, 10472 Controller wrap error	1. Run Enhanced Diagnostics
10473 Corrupt data. Low level format might be required	Information only
10480	1. Hard Disk Drive (ESDI) 2. Drive Cable 3. System Board
10481 ESDI drive D seek error	1. Run Enhanced Diagnostics
10482 Drive select acknowledgement bad	1. Run Enhanced Diagnostics
106X1	1. Check Configuration 2. Ethernet Adapter
10635	1. Power-off computer, wait ten seconds then power-on the computer 2. Ethernet Adapter
10651, 10660	1. Check Cables 2. Ethernet Adapter
106XX Not listed above	1. Ethernet Adapter
107XX	1. 5.25-inch External Diskette Drive 2. 5.25-inch Diskette Drive Adapter/A
109XX Check the adapter cables	1. ActionMedia Adapter/A 2. System Board 3. Riser card
112XX This adapter does not have cache	1. SCSI Adapter 2. Any SCSI Device 3. System Board 4. Riser card

POST Error Code	FRU/Action
119XX	1. 3119 Adapter
121XX	1. Modem Adapter 2. Any Serial Device 3. System Board 4. Riser card
136XX	1. ISDN Primary Rate Adapter 2. System Board 3. Riser card
137XX	1. System Board
141XX	1. Realtime Interface Coprocessor Portmaster Adapter/A
143XX	1. Japanese Display Adapter 2. System Board 3. Riser card
14710, 14711	1. System Board Video Adapter 2. Adapter Video Memory
148XX	1. Video Adapter
14901, 14902, 1491X, 14922	1. Video Adapter (if installed) 2. System Board 3. Riser card 4. Display (any type)
14932	1. External Display 2. Video Adapter
161XX	1. FaxConcentrator Adapter
164XX	1. 120 MB Internal Tape Drive 2. Diskette Cable 3. System Board 4. Riser card
16500	1. 6157 Tape Attachment 2. Adapter
16520, 16540	1. 6157 Streaming Tape Drive 2. 6157 Tape Attachment Adapter
166XX, 167XX	1. Token Ring Adapter 2. System Board 3. Riser card
18001 to 18029	1. Wizard Adapter 2. Wizard Adapter Memory
18031 to 18039	1. Wizard Adapter Cable

POST Error Code	FRU/Action
185XXXX	<ol style="list-style-type: none"> 1. DBCS Japanese Display Adapter/A 2. System Board 3. Riser card
20001 to 20003	<ol style="list-style-type: none"> 1. Image Adapter/A Image-I Adapter/A 2. Memory Module DRAM, VRAM
20004	<ol style="list-style-type: none"> 1. Memory Module DRAM, VRAM 2. Image Adapter/A Image-I Adapter/A
20005 to 20010	<ol style="list-style-type: none"> 1. Image Adapter/A Image-I Adapter/A 2. Memory Module DRAM, VRAM
200XX Not listed above	<ol style="list-style-type: none"> 1. Image Adapter/A 2. Image-I Adapter/A 3. Memory Module DRAM, VRAM 4. System Board 5. Riser card
20101 to 20103	<ol style="list-style-type: none"> 1. Printer/Scanner Option 2. Image Adapter/A 3. Memory Module DRAM, VRAM
20104	<ol style="list-style-type: none"> 1. Memory Module DRAM, VRAM 2. Printer/Scanner Option 3. Image Adapter/A
20105 to 20110	<ol style="list-style-type: none"> 1. Printer/Scanner Option 2. Image Adapter/A 3. Memory Module DRAM, VRAM
Image Adapter/A Memory Test failure indicated by graphic of adapter	<ol style="list-style-type: none"> 1. Replace memory module (shown in graphic)
206XX	<ol style="list-style-type: none"> 1. SCSI-2 Adapter 2. Any SCSI Device 3. System Board 4. Riser card
208XX Verify there are no duplicate SCSI ID settings on the same bus.	<ol style="list-style-type: none"> 1. Any SCSI Device
210XXXX Internal bus, size unknown 210XXX1 External bus, size unknown	<ol style="list-style-type: none"> 1. SCSI Hard Disk Drive 2. SCSI Adapter or System Board 3. SCSI Cable 4. SCSI ID Switch (on some models)
Tape Drive amber LED remains on	<ol style="list-style-type: none"> 1. Tape Drive 2. SCSI Cable (internal) 3. SCSI Adapter or System Board

POST Error Code	FRU/Action
Tape Drive green "in use" LED fails to come on	<ol style="list-style-type: none"> 1. Tape Drive 2. SCSI Adapter or System Board 3. SCSI Cable (internal) 4. SCSI Cable (external)
Tape automatically ejected from drive	<ol style="list-style-type: none"> 1. Tape Cassette Drive
SCSI ID on rotary switch does not match SCSI ID set in configuration. Verify drive switches inside cover are set to zero	<ol style="list-style-type: none"> 1. Rotary Switch Circuit Board 2. Circuit Board Cable 3. Tape Drive
Tape sticks or breaks in drive. Verify that the tapes used meet ANSI standard X3B5	<ol style="list-style-type: none"> 1. Tape Cassette
212XX	<ol style="list-style-type: none"> 1. SCSI Printer 2. Printer Cable
213XX	<ol style="list-style-type: none"> 1. SCSI Processor
214XX	<ol style="list-style-type: none"> 1. WORM Drive
215XXXC, 215XXXD, 215XXXE, 215XXXU If an external device, and power-on LED is off, check external voltages	<ol style="list-style-type: none"> 1. CD-ROM Drive I 2. CD-ROM Drive II Enhanced CD-ROM Drive II Any CD-ROM Drive 3. SCSI Cable 4. SCSI Adapter or System Board
216XX	<ol style="list-style-type: none"> 1. Scanner
217XX If an external device, and power-on LED is off, check external voltages	<ol style="list-style-type: none"> 1. Rewritable Optical Drive 2. SCSI Adapter or System Board 3. SCSI Cable
218XX Check for multi CD tray or jukebox	<ol style="list-style-type: none"> 1. Changer
219XX	<ol style="list-style-type: none"> 1. SCSI Communications Device
24201Y0, 24210Y0 Be sure wrap plug is attached	<ol style="list-style-type: none"> 1. ISDN/2 Adapter 2. ISDN/2 Wrap Plug 3. ISDN/2 Communications Cable
273XX	<ol style="list-style-type: none"> 1. 1 Mbps Micro Channel 2. Infrared LAN Adapter
27501, 27503, 27506, 27507	<ol style="list-style-type: none"> 1. ServerGuard Adapter 2. System Board 3. Riser card
27502, 27504, 27510, 27511, 27533, 27534, 27536, 27537	<ol style="list-style-type: none"> 1. ServerGuard Adapter
27509	<ol style="list-style-type: none"> 1. Remove redundant adapters, run Auto Configuration program, then retest.

POST Error Code	FRU/Action
27512	<ol style="list-style-type: none"> 1. WMSELF.DGS diagnostics file is missing 2. WMSELF.DGS diagnostics file is incorrect
27535	<ol style="list-style-type: none"> 1. 3V Lithium Backup Battery 2. ServerGuard Adapter
27554	<ol style="list-style-type: none"> 1. Internal Temperature out of range 2. ServerGuard Adapter
27555, 27556	<ol style="list-style-type: none"> 1. ServerGuard Adapter 2. Power Supply
27557	<ol style="list-style-type: none"> 1. 7.2V NiCad Main Battery Pack 2. ServerGuard Adapter
27558, 27559, 27560, 27561	<ol style="list-style-type: none"> 1. PCMCIA Type II Modem 2. ServerGuard Adapter
27562	<ol style="list-style-type: none"> 1. External Power Control not connected 2. External Power Control 3. ServerGuard Adapter
27563, 27564	<ol style="list-style-type: none"> 1. External Power Control 2. ServerGuard Adapter
275XX	<ol style="list-style-type: none"> 1. Update Diagnostic Software
27801 to 27879	<ol style="list-style-type: none"> 1. Personal Dictation System 2. Adapter 3. System Board
27880 to 27889	<ol style="list-style-type: none"> 1. External FRU (Speaker, Microphone)
999030X Hard disk reset failure	<ol style="list-style-type: none"> 1. Possible hard disk drive problem; see "Hard disk drive boot error" on page 39.

Miscellaneous error messages

Message/Symptom	FRU/Action
CMOS Backup Battery inaccurate	<ol style="list-style-type: none"> 1. CMOS Backup Battery (see “Safety information” on page 93) 2. System Board
Changing colors	<ol style="list-style-type: none"> 1. Display
Computer will <i>not</i> power-off. See “Power Supply Errors” on page 39.	<ol style="list-style-type: none"> 1. Power Switch 2. System Board 3. Riser card
Computer will <i>not</i> RPL from server	<ol style="list-style-type: none"> 1. Ensure that network is in startup sequence as first device or first device after diskette 2. Ensure that network adapter is enabled for RPL 3. Network adapter (Advise network administrator of new MAC address)
Computer will <i>not</i> Wake On LAN (if applicable)	<ol style="list-style-type: none"> 1. Check power supply and signal cable connections to network adapter 2. Ensure that the operating system settings are set to enable Wake on LAN 3. Ensure Wake On LAN feature is enabled in Setup/Configuration (see “Setup Utility program” on page 12) 4. Ensure network administrator is using correct MAC address 5. Ensure no interrupt or I/O address conflicts 6. Network adapter (advise network administrator of new MAC address)
Dead computer. See “Power Supply Errors” on page 39.	<ol style="list-style-type: none"> 1. Power Supply 2. System Board 3. Riser card
Diskette drive in-use light remains on or does not light when drive is active.	<ol style="list-style-type: none"> 1. Diskette Drive 2. System Board 3. Diskette Drive Cable 4. Riser card
Flashing cursor with an otherwise blank display.	<ol style="list-style-type: none"> 1. System Board 2. Primary Hard Disk Drive 3. Hard Disk Drive Cable 4. Riser card
Incorrect memory size during POST	<ol style="list-style-type: none"> 1. Run the Memory tests 2. Memory Module 3. System Board

Message/Symptom	FRU/Action
"Insert a Diskette" icon appears with a known-good diagnostics diskette in the first 3.5-inch diskette drive.	<ol style="list-style-type: none"> 1. System Board 2. Diskette Drive Cable 3. Riser card 4. Network Adapter
Intensity or color varies from left to right of characters and color bars	<ol style="list-style-type: none"> 1. Display 2. System Board
No power or fan not running	1. See "Power Supply Errors" on page 39.
Non-system disk or disk error-type message with a known-good diagnostic diskette.	<ol style="list-style-type: none"> 1. Diskette Drive 2. System Board 3. Diskette Drive Cable 4. Riser card
Other display symptoms not listed above (including blank or illegible display)	<ol style="list-style-type: none"> 1. Display 2. System Board
Power-on indicator or hard disk drive in-use light not on, but computer works correctly	<ol style="list-style-type: none"> 1. Power Supply 2. System Board 3. LED Cables
Printer problems	1. Printer
Program loads from the hard disk with a known-good diagnostics diskette in the first 3.5-inch diskette drive	<ol style="list-style-type: none"> 1. Run Setup 2. Diskette Drive 3. Diskette Drive Cable 4. System Board 5. Riser card 6. Power Supply
RPL computer cannot access programs from its own hard disk.	<ol style="list-style-type: none"> 1. If network administrator is using LCCM Hybrid RPL, check startup sequence: <ol style="list-style-type: none"> a. First device - network b. Second device - hard disk 2. Hard disk drive
RPL computer does not RPL from server	<ol style="list-style-type: none"> 1. Check startup sequence 2. Check the network adapter LED status
Serial or parallel port device failure (system board port)	<ol style="list-style-type: none"> 1. External Device Self-Test OK? 2. External Device 3. Cable 4. System Board
Serial or parallel port device failure (adapter port)	<ol style="list-style-type: none"> 1. External Device Self-Test OK? 2. External Device 3. Cable 4. Alternate Adapter 5. System Board

Message/Symptom	FRU/Action
Some or all keys on the keyboard do not work	<ol style="list-style-type: none"> 1. Keyboard 2. Keyboard Cable 3. System Board

Undetermined problems

Check the power supply voltages (see “Power Supply Errors” on page 39). If the voltages are correct, return here and continue with the following steps.

1. Power-off the computer.
2. Remove or disconnect the following components (if installed) one at a time.
 - a. Non-IBM devices
 - b. External devices (modem, printer, or mouse)
 - c. Any adapters
 - d. Riser card
 - e. Memory modules
 - f. Extended video memory
 - g. External Cache
 - h. External Cache RAM
 - i. Hard disk drive
 - j. Diskette drive
3. Power-on the computer to re-test the system.
4. Repeat steps 1 through 3 until you find the failing device or adapter.

If all devices and adapters have been removed, and the problem continues, replace the system board (see “System board” on page 38).

Chapter 8. Parts listing

This section lists the replaceable FRUs for Machine Type 6029.

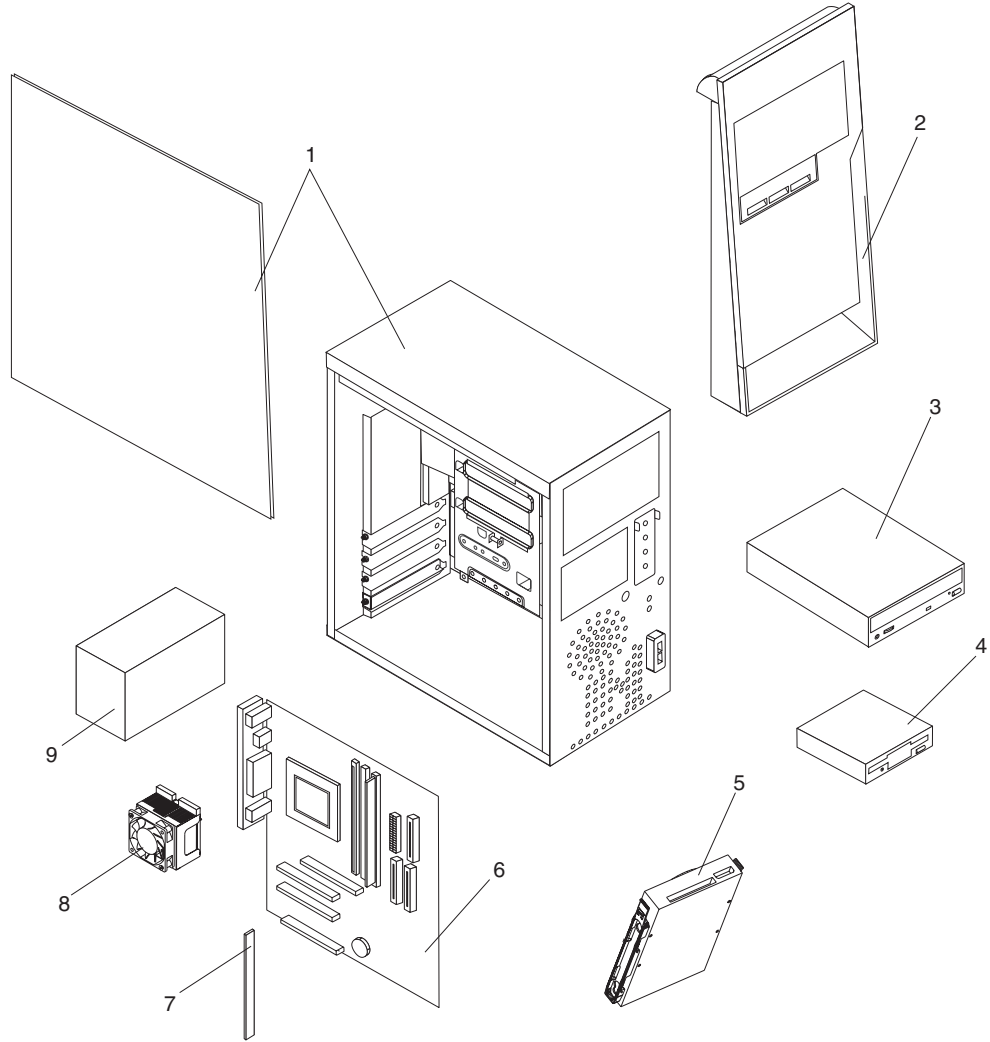

Machine Type 6029		
1	Chassis complete w/Cvrs (Black) (models 22A 22C 23C 26A 26C 32A 32C 33C 36A 36C 12A 12C 13C 16A 16C)	49P4537
1	Chassis complete w/Cvrs (White) (models 10A 10C 30A 30C 40A 40C 50A 50C)	49P4540
2	Bezel (Black) (models 22A 22C 23C 26A 26C 32A 32C 33C 36A 36C 12A 12C 13C 16A 16C)	49P4538
2	Bezel (White) (models 10A 10C 30A 30C 40A 40C 50A 50C)	49P4541
3	CD-ROM Drive 48X (Black) (models 26A 26C 36A 36C 16A 16C)	33P3203
3	CD-ROM Drive 48X (Black) (models 26A 26C 36A 36C 16A 16C)	33P3207

Machine Type 6029		
3	CD-ROM Drive 48X (Black) (models 26A 26C 36A 36C 16A 16C)	33P3211
3	CD-ROM Drive (Black) (models 26A 26C 36A 36C 16A 16C)	33P3215
3	CD-ROM Drive (White) (models 30A 30C 50A 50C)	33P3213
3	CD-ROM Drive (White) (models 30A 30C 50A 50C)	33P3201
3	CD-ROM Drive (White) (models 30A 30C 50A 50C)	33P3209
3	CD-ROM Drive (White)(models 30A 30C 50A 50C)	33P3205
3	CD-ROM Drive (White) (models 30A 30C 50A 50C)	33P3215
4	3.5-in. 1.44 M 2-mode Floppy Disk Drive (All models)	75H9550
5	20GB Hard Drive 5400 rpm (models 22A 22C 23C 32A 32C 33C 12A 12C 13C 10A 10C 40A 40C)	19K1560
5	40GB Hard Drive 5400rpm (models 26A 26C 36A 36C 16A 16C 30A 30C 50A 50C)	19K1562
6	System Board (all models)	33P0825
7	128MB Memory 133MHz (all models)	33L3074
8	Fan Sink (all models)	22P4368
9	Power Supply 145W (all models)	49P4539
	Processor - Tualitin 1.1GHz (models 12A 12C 13C 16A 16C 40A 40C 50A 50C)	49P3427
	Processor - Tualitin 1.2GHz (models 22A 22C 23C 26A 26C)	33P0809
	Processor - Tualitin 1.3GHz (models 32A32C 33C 36A 36C 10A 10C 30A 30C)	33P0811
	Cable G (FDD) (all models)	22P2400
	Cable USB (all models)	25P6152
	Cable HDD (all models)	37L4525
	Cable ATA66 2 drop (all models)	37L5098
	Cable CDROM audio (all models)	75H9219
	Mouse, PS2 2-button, black (models 22A 22C 23C 26A 26C 32A 32C 33C 36A 36C 12A 12C 13C 16A 16C 12A 12C 13C 16A 16C)	24P0383
	Mouse, PS2 2-button, white (models 10A 10C 30A 30C 40A 40C 50A 50C)	24P0381

Recovery CDs Win XP Home		
	US English (models 22A 32A 12A)	49P0998
	Simplified Chinese (models 22C 32C 12C)	46P6797

Recovery CDs Win Xp Pro		
	US English (Models 26A 36A 16A)	49P0995
	Simplified Chinese (models 23C 26C 33C 36C 13C 16C)	62P4773

Keyboards (Standard PS/2 Black)		
	US English (models 22A 26A 32A 36A 12A 16A)	32P5000

	Keyboards (Standard PS/2 Black)	
	Arabic	32P5001
	Belgian/French	32P5002
	Belgian/UK	32P5003
	Bulgarian	32P5004
	Chinese/US (models 22C 23C 26C 32C 33C 36C 12C 13C 16C)	32P5005
	Czech	32P5006
	Danish	32P5007
	Dutch	32P5008
	French	32P5009
	French Canadian	32P5010
	French Canadian	32P5011
	German	32P5012
	Greek	32P5013
	Hebrew	32P5014
	Hungarian	32P5015
	Iceland	32P5016
	Italian	32P5017
	Japanese	32P5018
	Korean	32P5019
	LA Spanish	32P5020
	Norwegian	32P5021
	Polish	32P5022
	Portugese	32P5023
	Romanian	32P5024
	Russian	32P5025
	Russian/Cy	32P5026
	Serbian/Cyrillic	32P5027
	Slovak	32P5028
	Spanish	32P5029
	Swedish/Finn	32P5030
	Swiss F/G	32P5031
	Thailand	32P5032
	Turkish	32P5033
	Turkish	32P5034
	UK English	32P5035
	US International	32P5036
	Yugoslav/Latin	32P5037
	Brazil/Portugese	32P5038

	Keyboards (Standard PS/2 White)	
	US English (models 10A 30A 40A 50A)	32P5040
	Arabic	32P5041
	Belgian/French	32P5042
	Belgian/UK	32P5043
	Bulgarian	32P5044
	Chinese/US (models 10C 30C 40C 50C)	32P5045
	Czech	32P5046
	Danish	32P5047
	Dutch	32P5048
	French	32P5049
	French Canadian	32P5050
	French Canadian	32P5051
	German	32P5052
	Greek	32P5053
	Hebrew	32P5054
	Hungarian	32P5055
	Iceland	32P5056
	Italian	32P5057
	Japanese	32P5058
	Korean	32P5059
	LA Spanish	32P5060
	Norwegian	32P5061
	Polish	32P5062
	Portugese	32P5063
	Romanian	32P5064
	Russian	32P5065
	Russian/Cy	32P5066
	Serbian/Cyrillic	32P5067
	Slovak	32P5068
	Spanish	32P5069
	Swedish/Finn	32P5070
	Swiss F/G	32P5071
	Thailand	32P5072
	Turkish	32P5073
	Turkish	32P5074
	UK English	32P5075
	US International	32P5076
	Yugoslav/Latin	32P5077
	Brazil/Portugese	32P5078

	Power Cords	
	Line Cord (models 12A 16A 10A 30A 40A 50A)	6952301
	Line Cord (models 12A 16A 10A 30A 40A 50A)	13F9939
	Line Cord (models 12A 16A 10A 30A 40A 50A)	13F9978
	Line Cord (models 22A 26A 32A 36A 12A 16A 10A 30A 40A 50A)	14F0032
	Line Cord	13F9996
	Line Cord	14F0068
	Line Cord	36L8879
	Line Cord (models 22C 23C 26C 32C 33C 36C 12C 13C 16C 10C 30C 40C 50C)	02K0545
	Line Cord	14F0086
	Line Cord (models 12A 16A 10A 30A 40A 50A)	14F0014
	Line Cord	14F0050

Chapter 9. Additional Service Information

Security features

Security features in this section include the following:

- Passwords
- Vital Product Data
- Management Information Format (MIF)
- Alert on LAN

Passwords

The following section provides information about computer hardware and software-related passwords.

- Power-on Password
- Administrator Password
- Operating System Password

Power-on and Administrator passwords are set in the Setup Utility program. See “Setup Utility program” on page 12 for information about running the Setup Utility.

Power-on password

A power-on password denies access to the computer by an unauthorized user when the computer is powered on. When a power-on password is active, the password prompt appears on the screen each time the computer is powered on. The computer starts after the proper password is entered.

Removing a power-on password

To service a computer with an active and unknown power-on password, power-off the computer and use the following procedure.

Note: On some models, this procedure will also remove the administrator password.
--

1. Unplug the power cord and remove the top cover.
2. Refer to “Identifying parts on the system board - small desktop model” on page 31 to find the Virtual clear CMOS/BIOS recovery jumper.
3. Move the recovery jumper from **normal** to **ROM recovery**.
4. Power-on the computer. The system senses the change in the position and erases the password.
5. Wait 30 seconds for beeps to sound, and then power down by holding the power button for 10 seconds.
6. Return the jumper to normal position.
7. Reset the date and time and remind the user to enter a new password when service is complete.

Administrator password

The administrator password is used to restrict access to the Configuration/Setup Utility program. If the administrator password is activated, and you do not enter the administrator password, the configuration can be viewed but not changed.

Note:

Type 6029 computers have Enhanced Security Mode. If Enhanced Security mode is enabled and there is no password given, the computer will act as if Enhanced Security is disabled.

If Enhanced Security is Enabled and an administrator password is given, the administrator password must be entered to use the computer. If the administrator password is lost or forgotten, the system board in the computer must be replaced in order to regain access to the Configuration/Setup Utility program.

Administrator password control

The Administrator password is set in the Setup Configuration. Refer to “Setup Utility program” on page 12.

Operating system password

An operating system password is very similar to a power-on password and denies access to the computer by an unauthorized user when the password is activated. The computer is unusable until the password is entered and recognized by the computer.

Vital product data

Each computer has a unique Vital Product Data (VPD) code stored in the nonvolatile memory on the system board. After you replace the system board, the VPD must be updated. To update the VPD, see “Flash (BIOS/VPD) update procedure” on page 89.

Management Information Format (MIF)

Management Information Format (MIF) is a file used to maintain a list of the system unit serial number along with all serialized components (for example, system board, riser card, memory, and processor).

At the time of computer manufacture, the EPROM will be loaded with the serial numbers of the system and all major components. The customer will have access to the MIF file via the DMI MIF Browser that is installed with the preload and is also available on the SSCD that is provided with the system.

A company called Retain-a-Group is a central data warehouse offering serial number data management. Retain-a-Group acts as a focal point to law enforcement. The customer has the option to purchase serial number information and services from Retain-a-Group. It is the customer’s responsibility to maintain the MIF file and to inform Retain-a-Group of any changes to the file.

Some customers may request their servicers to assist them in maintaining the MIF file when serialized components are replaced during hardware service. This assistance is between the customer and the servicer. The servicer can use the DMI MIF Browser to update the MIF information in the EPROM. It is anticipated that some servicers might charge for this service.

To update the EPROM using the DMI MIF Browser, use the following procedure.

1. Click **Start** from the desktop, then **Programs**.
2. Select **IBM SystemView Agent**
3. Select the **Serial Number Information** icon
4. Click the plus sign to expand.
5. Select the component you want to view or edit.

6. Double click on the component you want to change.
7. Enter new data in the *Value* field, then click **Apply**.

Alert on LAN

Alert on LAN provides notification of changes in the computer, even when the computer power is turned off. Working with DMI and Wake on LAN[®] technologies, Alert on LAN helps to manage and monitor the hardware and software features of the computer. Alert on LAN generates notifications to the server of these occurrences:

- Computer disconnected from the network
- Computer unplugged from the power outlet
- All POST errors
- Operating system or POST hang condition

Alert on LAN events are configured to be Enabled or Disabled from the LAN server only, and not from the computer. See the LAN administrator for configuration status information.

BIOS levels

An incorrect level of BIOS can cause false errors and unnecessary FRU replacement. Use the following information to determine the current level of BIOS installed in the computer, the latest BIOS available for the computer, and where to obtain the latest level of BIOS.

- Current Level BIOS information
 - Run the Configuration Utility to determine the level of BIOS installed.
- Sources for determining the latest level BIOS available
 1. IBM Home Page
<http://www.ibm.com/pc/us/>
 2. PC PartnerInfo-Technical Database (CTSTIPS.NSF)
 3. HelpCenter[®]
 4. Levels 1 and 2 Support
 5. RETAIN[®]
- Sources for obtaining the latest level BIOS available
 1. IBM Home Page
<http://www.ibm.com/pc/us/>
 2. PC PartnerInfo-Technical Database (CTSTIPS.NSF)
 3. HelpCenter
 4. Levels 1 and 2 Support

To update (flash) the BIOS, see “Flash (BIOS/VPD) update procedure” on page 89.

Flash (BIOS/VPD) update procedure

Attention:

Refer to the information label located inside the system unit cover for any model-specific information.

1. Power-off the computer.

2. Insert the flash update diskette into drive A.
3. Power-on the computer.
4. When the Update Utility appears; select the country/keyboard, then press **Enter**.
5. If the computer serial number was previously recorded, the number is displayed with an option to update it. Press **Y** to update the serial number.
6. Type the 7-digit serial number of the computer you are servicing, then press **Enter**.
7. Follow the instructions on the screen to complete the flash (BIOS/VPD) update procedure.

Flash recovery boot block jumper

Attention:

If an interruption occurs during a Flash/BIOS upgrade, the BIOS might be left in an unusable state. The Boot Block jumper enables you to restart the system and recover the BIOS.

To perform a Flash/BIOS recovery using the recovery jumper, use the following procedure.

1. Power-off the computer and remove the cover.
2. Move the system board Virtual clear CMOS/BIOS recovery jumper to the **ROM recovery** position. Refer to "Identifying parts on the system board" on page 24 or the label inside the computer for more information.
3. Insert the upgrade diskette into the diskette drive.
4. Power-on the computer. The IBM Logo will appear.
5. When the Flash Update Utility appears, select the country/keyboard, then press **Enter**.
6. If the computer serial number was previously recorded, the number is displayed with an option to update it. Press **Y** to update the serial number.
7. Type the 7-digit serial number of the computer you are servicing, then press **Enter**.
8. Follow the instructions on the screen to complete the flash (BIOS/VPD) update procedure.
9. When you are instructed to reboot the computer, power-off the computer and move the recovery jumper to the **normal** position. Then replace the cover and power-on the computer.

Power management

Power management reduces the power consumption of certain components of the computer such as the system power supply, processor, hard disk drives, and some monitors. Advanced Power Management and Rapid Resume™ Manager are features of some personal computers.

Automatic configuration and power interface (ACPI) BIOS

Being an ACPI BIOS system, the operating system is allowed to control the power management features of the computer and the setting for Advanced Power Management (APM) BIOS mode are ignored. Not all operating systems support ACPI BIOS mode.

Advanced Power Management

Energy-saving settings can be viewed and changed by using the Advanced Power Management menu in the Configuration/Setup Utility program.

Attention:

If a device, such as a monitor, does not have power-management capabilities, it can be damaged when exposed to a reduced-power state. Before making energy-saving selections for the monitor, check the documentation supplied with the monitor to see if it supports Display Power Management Signaling (DPMS).

Automatic Hardware Power Management features

Automatic Hardware Power Management can reduce the power states of the computer, processor, and monitor (if the monitor supports DPMS) if they are inactive for a predetermined length of time.

Set the time for the system to enter a low-power state.

You can define the amount of energy savings by specifying values for the following options.

-

System Power

- Select **On** for the computer to remain on.
- Select **Off** for the computer to shut down.

-

Display

Set display to be disabled or to be reduced at these power states:

- **Standby:** Screen is blank, but can be restored immediately when any activity is detected.
- **Suspend:** Monitor uses less power than in Standby mode. Screen image is restored after a few seconds when any activity is detected.
- **Off:** Monitor power is off. Press Monitor power button to restore power. On some monitors, you might have to depress the power button twice.

Setting Automatic Hardware Power Management features

1. Start the Configuration/Setup Utility program (see “Setup Utility program” on page 12).

2. Select **Power Management** from the Configuration/Setup Utility program menu.
3. Select **APM BIOS Mode** within the APM sub menu and be sure it is set to **Enabled**. If it is not, press Left Arrow (←) or Right Arrow (→) to change the setting.
4. Select **Automatic Hardware Power Management**.
5. Set **Automatic Hardware Power Management** to **Enabled**.
6. Select values for the three categories of power management (system power, processor speed, and display), as necessary.
7. Set **Hard Disk** to **Enabled** or **Disabled**.

Note: This does not apply to SCSI drives.

8. Press **Esc** twice to return to the Configuration/Setup Utility program menu.
9. Before you exit from the program, select **Save Settings** from the Configuration/Setup Utility program menu.
10. To exit from the Configuration/Setup Utility program, press **Esc** and follow the instructions on the screen.

Automatic Power-On features

The Automatic Power-On features within the Power Management menu allow you to enable and disable features that turn on the computer automatically.

- **Serial Port A Ring Detect:** With this feature set to **Enabled** and an external modem connected to serial port (COM1), the computer will turn on automatically when a ring is detected on the modem.
- **PCI Modem Ring Detect:** With this feature set to **Enabled**, the computer will turn on automatically when a ring is detected on the internal modem.
- **PCI Wake Up:** This feature allow PCI cards that support this capability to wake the system.
- **Wake Up on Alarm:** You can specify a date and time at which the computer will be turned on automatically. This can be either a single event or a daily event.
- **Wake on LAN:** If the computer has a properly configured token-ring or Ethernet LAN adapter card that is Wake on LAN-enabled and there is remote network management software, you can use the IBM-developed Wake on LAN feature. When you set Wake on LAN to **Enabled**, the computer will turn on when it receives a specific signal from another computer on the local area network (LAN).

Chapter 10. Related service information

Note: The service procedures are designed to help you isolate problems. They are written with the assumption that you have model-specific training on all computers, or that are familiar with the computers, functions, terminology, and service information provided in this manual.

Safety information

The following section contains the safety information that you need to be familiar with before servicing an IBM computer.

General safety

Follow these rules to ensure general safety:

- Observe good housekeeping in the area of the machines during and after maintenance.
- When lifting any heavy object:
 1. Ensure you can stand safely without slipping.
 2. Distribute the weight of the object equally between your feet.
 3. Use a slow lifting force. Never move suddenly or twist when you attempt to lift.
 4. Lift by standing or by pushing up with your leg muscles; this action removes the strain from the muscles in your back. *Do not attempt to lift any objects that weigh more than 16 kg (35 lb) or objects that you think are too heavy for you.*
- Do not perform any action that causes hazards to the customer, or that makes the equipment unsafe.
- Before you start the machine, ensure that other service representatives and the customer's personnel are not in a hazardous position.
- Place removed covers and other parts in a safe place, away from all personnel, while you are servicing the machine.
- Keep your tool case away from walk areas so that other people will not trip over it.
- Do not wear loose clothing that can be trapped in the moving parts of a machine. Ensure that your sleeves are fastened or rolled up above your elbows. If your hair is long, fasten it.
- Insert the ends of your necktie or scarf inside clothing or fasten it with a nonconductive clip, approximately 8 centimeters (3 inches) from the end.
- Do not wear jewelry, chains, metal-frame eyeglasses, or metal fasteners for your clothing.

Remember: Metal objects are good electrical conductors.
- Wear safety glasses when you are: hammering, drilling soldering, cutting wire, attaching springs, using solvents, or working in any other conditions that might be hazardous to your eyes.
- After service, reinstall all safety shields, guards, labels, and ground wires. Replace any safety device that is worn or defective.
- Reinstall all covers correctly before returning the machine to the customer.

Electrical safety



CAUTION:

Electrical current from power, telephone, and communication cables can be hazardous. To avoid personal injury or equipment damage, disconnect the attached power cords, telecommunication systems, networks, and modems before you open the server covers, unless instructed otherwise in the installation and configuration procedures.

Observe the following rules when working on electrical equipment.

Important: Use only approved tools and test equipment. Some hand tools have handles covered with a soft material that does not insulate you when working with live electrical currents.

Many customers have, near their equipment, rubber floor mats that contain small conductive fibers to decrease electrostatic discharges. Do not use this type of mat to protect yourself from electrical shock.

- Find the room emergency power-off (EPO) switch, disconnecting switch, or electrical outlet. If an electrical accident occurs, you can then operate the switch or unplug the power cord quickly.
- Do not work alone under hazardous conditions or near equipment that has hazardous voltages.
- Disconnect all power before:
 - Performing a mechanical inspection
 - Working near power supplies
 - Removing or installing main units
- Before you start to work on the machine, unplug the power cord. If you cannot unplug it, ask the customer to power-off the wall box that supplies power to the machine and to lock the wall box in the off position.
- If you need to work on a machine that has exposed electrical circuits, observe the following precautions:
 - Ensure that another person, familiar with the power-off controls, is near you.
Remember: Another person must be there to switch off the power, if necessary.
 - Use only one hand when working with powered-on electrical equipment; keep the other hand in your pocket or behind your back.
Remember: There must be a complete circuit to cause electrical shock. By observing the above rule, you may prevent a current from passing through your body.
 - When using testers, set the controls correctly and use the approved probe leads and accessories for that tester.
 - Stand on suitable rubber mats (obtained locally, if necessary) to insulate you from grounds such as metal floor strips and machine frames.

Observe the special safety precautions when you work with very high voltages; these instructions are in the safety sections of maintenance information. Use extreme care when measuring high voltages.

Observe the special safety precautions when you work with very high voltages; these instructions are in the safety sections of maintenance information. Use extreme care when measuring high voltages.

- Regularly inspect and maintain your electrical hand tools for safe operational condition.
- Do not use worn or broken tools and testers.
- *Never assume* that power has been disconnected from a circuit. First, *check* that it has been powered-off.
- Always look carefully for possible hazards in your work area. Examples of these hazards are moist floors, nongrounded power extension cables, power surges, and missing safety grounds.
- Do not touch live electrical circuits with the reflective surface of a plastic dental mirror. The surface is conductive; such touching can cause personal injury and machine damage.
- Do not service the following parts with the power on when they are removed from their normal operating places in a machine:
 - Power supply units
 - Pumps
 - Blowers and fans
 - Motor generators

and similar units. (This practice ensures correct grounding of the units.)

- If an electrical accident occurs:
 - Use caution; do not become a victim yourself.
 - Switch off power.
 - Send another person to get medical aid.

Safety inspection guide

The intent of this inspection guide is to assist you in identifying potentially unsafe conditions on these products. Each machine, as it was designed and built, had required safety items installed to protect users and service personnel from injury. This guide addresses only those items. However, good judgment should be used to identify potential safety hazards due to attachment of non-IBM features or options not covered by this inspection guide.

If any unsafe conditions are present, you must determine how serious the apparent hazard could be and whether you can continue without first correcting the problem.

Consider these conditions and the safety hazards they present:

- Electrical hazards, especially primary power (primary voltage on the frame can cause serious or fatal electrical shock).
- Explosive hazards, such as a damaged CRT face or bulging capacitor
- Mechanical hazards, such as loose or missing hardware

The guide consists of a series of steps presented in a checklist. Begin the checks with the power off, and the power cord disconnected.

Checklist:

1. Check exterior covers for damage (loose, broken, or sharp edges).
2. Power-off the computer. Disconnect the power cord.

3. Check the power cord for:
 - a. A third-wire ground connector in good condition. Use a meter to measure third-wire ground continuity for 0.1 ohm or less between the external ground pin and frame ground.
 - b. The power cord should be the appropriate type as specified in the parts listings.
 - c. Insulation must not be frayed or worn.
4. Remove the cover.
5. Check for any obvious non-IBM alterations. Use good judgment as to the safety of any non-IBM alterations.
6. Check inside the unit for any obvious unsafe conditions, such as metal filings, contamination, water or other liquids, or signs of fire or smoke damage.
7. Check for worn, frayed, or pinched cables.
8. Check that the power-supply cover fasteners (screws or rivets) have not been removed or tampered with.

Handling electrostatic discharge-sensitive devices

Any computer part containing transistors or integrated circuits (ICs) should be considered sensitive to electrostatic discharge (ESD). ESD damage can occur when there is a difference in charge between objects. Protect against ESD damage by equalizing the charge so that the machine, the part, the work mat, and the person handling the part are all at the same charge.

Notes:

1. Use product-specific ESD procedures when they exceed the requirements noted here.
2. Make sure that the ESD protective devices you use have been certified (ISO 9000) as fully effective.

When handling ESD-sensitive parts:

- Keep the parts in protective packages until they are inserted into the product.
- Avoid contact with other people.
- Wear a grounded wrist strap against your skin to eliminate static on your body.
- Prevent the part from touching your clothing. Most clothing is insulative and retains a charge even when you are wearing a wrist strap.
- Use the black side of a grounded work mat to provide a static-free work surface. The mat is especially useful when handling ESD-sensitive devices.
- Select a grounding system, such as those listed below, to provide protection that meets the specific service requirement.

Note: The use of a grounding system is desirable but not required to protect against ESD damage.

- Attach the ESD ground clip to any frame ground, ground braid, or green-wire ground.
- Use an ESD common ground or reference point when working on a double-insulated or battery-operated system. You can use coax or connector-outside shells on these systems.
- Use the round ground-prong of the ac plug on ac-operated computers.

Grounding requirements

Electrical grounding of the computer is required for operator safety and correct system function. Proper grounding of the electrical outlet can be verified by a certified electrician.

Safety notices (multi-lingual translations)

The caution and danger safety notices in this section are provided in the following languages:

- English
- Brazilian/Portuguese
- Chinese
- French
- German
- Italian
- Korean
- Spanish



DANGER

Electrical current from power, telephone and communication cables is hazardous.

To avoid a shock hazard:

- **Do not connect or disconnect any cables or perform installation, maintenance, or reconfiguration of this product during an electrical storm.**
- **Connect all power cords to a properly wired and grounded electrical outlet.**
- **Connect to properly wired outlets any equipment that will be attached to this product.**
- **When possible, use one hand only to connect or disconnect signal cables.**
- **Never turn on any equipment when there is evidence of fire, water, or structural damage.**
- **Disconnect the attached power cords, telecommunications systems, networks, and modems before you open the device covers, unless instructed otherwise in the installation and configuration procedures.**
- **Connect and disconnect cables as described in the following table when installing, moving, or opening covers on this product or attached devices.**

To Connect	To Disconnect
<ol style="list-style-type: none">1. Turn everything OFF.2. First, attach all cables to devices.3. Attach signal cables to connectors.4. Attach power cords to outlet.5. Turn device ON.	<ol style="list-style-type: none">1. Turn everything OFF.2. First, remove power cords from outlet.3. Remove signal cables from connectors.4. Remove all cables from devices.



CAUTION:

When replacing the lithium battery, use only IBM Part Number 33F8354 or an equivalent type battery recommended by the manufacturer. If your system has a module containing a lithium battery, replace it only with the same module type made by the same manufacturer. The battery contains lithium and can explode if not properly used, handled, or disposed of.

Do not:

- Throw or immerse into water
- Heat to more than 100°C (212°F)
- Repair or disassemble

Dispose of the battery as required by local ordinances or regulations.



CAUTION:

When laser products (such as CD-ROMs, DVD-ROM drives, fiber optic devices, or transmitters) are installed, note the following:

- Do not remove the covers. Removing the covers of the laser product could result in exposure to hazardous laser radiation. There are no serviceable parts inside the device.
- Use of controls or adjustments or performance of procedures other than those specified herein might result in hazardous radiation exposure.



DANGER: Some laser products contain an embedded Class 3A or Class 3B laser diode. Note the following:

Laser radiation when open. Do not stare into the beam, do not view directly with optical instruments, and avoid direct exposure to the beam.

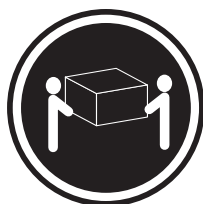

≥18 kg (37 lbs)

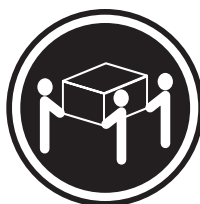

≥32 kg (70.5 lbs)

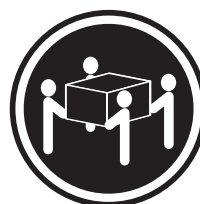

≥55 kg (121.2 lbs)

CAUTION:
Use safe practices when lifting.



CAUTION:
The power control button on the device and the power switch on the power supply do not turn off the electrical current supplied to the device. The device also might have more than one power cord. To remove all electrical current from the device, ensure that all power cords are disconnected from the power source.

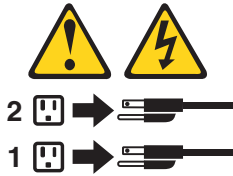

CAUTION:

Do not place any object weighing more than 82 kg (180 lbs.) on top of rack-mounted devices.





PERIGO

A corrente elétrica proveniente de cabos de alimentação, de telefone e de comunicações é perigosa.

Para evitar risco de choque:

- Não conecte ou desconecte cabos e não realize instalação, manutenção ou reconfiguração deste produto durante uma tempestade com raios.
- Conecte todos os cabos de alimentação a tomadas elétricas corretamente instaladas e aterradas.
- Conecte todos os equipamentos ao qual esse produto será conectado a tomadas corretamente instaladas.
- Sempre que possível, utilize apenas uma das mãos para conectar ou desconectar cabos de sinal.
- Nunca ligue qualquer equipamento quando existir evidência de danos por fogo, água ou na estrutura.
- Desconecte cabos de alimentação, sistemas de telecomunicação, redes e modems antes de abrir as tampas dos dispositivos, a menos que especificado de maneira diferente nos procedimentos de instalação e configuração.
- Conecte e desconecte cabos conforme descrito na seguinte tabela, ao instalar ou movimentar este produto ou os dispositivos conectados, ou ao abrir suas tampas.

Para Conectar:	Para Desconectar:
<ol style="list-style-type: none">1. DESLIGUE Tudo.2. Primeiramente, conecte todos os cabos aos dispositivos.3. Conecte os cabos de sinal aos conectores.4. Conecte os cabos de alimentação às tomadas.5. LIGUE os dispositivos.	<ol style="list-style-type: none">1. DESLIGUE Tudo.2. Primeiramente, remova os cabos de alimentação das tomadas.3. Remova os cabos de sinal dos conectores.4. Remova todos os cabos dos dispositivos.



CUIDADO:

Ao substituir a bateria de lítio, utilize apenas uma bateria IBM, Número de Peça 33F8354 ou uma bateria de tipo equivalente, recomendada pelo fabricante. Se o seu sistema possui um módulo com uma bateria de lítio, substitua-o apenas pelo mesmo tipo de módulo, do mesmo fabricante. A bateria contém lítio e pode explodir se não for utilizada, manuseada e descartada de maneira correta.

Não:

- Jogue ou coloque na água
- Aqueça a mais de 100°C (212°F)

- Conserte nem desmonte

Para descartar a bateria, entre em contato com a área de atendimento a clientes IBM, pelo telefone (011) 889-8986, para obter informações sobre como enviar a bateria pelo correio para a IBM.



PRECAUCIÓN:

Quando produtos a laser (unidades de CD-ROM, unidades de DVD, dispositivos de fibra ótica, transmissores, etc.) estiverem instalados, observe o seguinte:

- Não remova as tampas. A remoção das tampas de um produto a laser pode resultar em exposição prejudicial à radiação de laser. Nenhuma peça localizada no interior do dispositivo pode ser consertada.
- A utilização de controles ou ajustes ou a execução de procedimentos diferentes dos especificados aqui pode resultar em exposição prejudicial à radiação.

PERIGO

Alguns produtos a laser contêm um diodo laser da Classe 3A ou Classe 3B embutido. Observe o seguinte:

Radiação de laser quando aberto. Não olhe diretamente para o raio a olho nu ou com instrumentos óticos, e evite exposição direta ao raio.

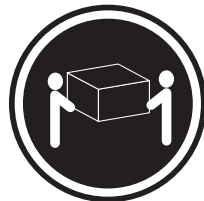

≥18 kg (37 lbs)



≥32 kg (70.5 lbs)



≥55 kg (121.2 lbs)

CUIDADO:

Ao levantar a máquina, faça-o com segurança.



CUIDADO:

Os botões Liga/Desliga localizados no dispositivo e na fonte de alimentação não desligam a corrente elétrica fornecida ao dispositivo. O dispositivo também pode ter mais de um cabo de alimentação. Para remover toda a corrente elétrica do dispositivo, assegure que todos os cabos de alimentação estejam desconectados da

fonte de energia elétrica.



CUIDADO:



CUIDADO:



Não coloque nenhum objeto com peso superior a 82 kg (180 lbs.) sobre dispositivos montados em rack.

重要:

Server Library 中的所有提醒和危险条款前都有一个数字标识。该数字是用来交叉引用一个英文的提醒和危险条款及本部分中的与之对应的已翻译成其它文字的提醒和危险条款。

例如, 如果一个提醒条款前的数字为 1, 则本部分中相应的译文也带有标号 1。

在执行任何指示的操作之前, 请确保您已经阅读了全部提醒和危险条款。

声明 1



危险

电源、电话和通信电缆中带有危险电流。
为避免电击:
雷电期间不要拆接电缆或安装、维修及重新配置本产品。
将所有电源线连接至正确布线并已安全接地的电源插座上。
将与本产品连接的所有设备连接至正确布线的插座上。
尽量只使用单手拆接信号电缆。
有水、火及结构损坏迹象时, 请勿打开任何设备。
除非在安装配置过程中有明确指示, 否则, 打开设备机盖前应先断开与电源线、远程通信系统、网络和调制解调器的所有连接。
安装、移动或打开本产品及其附带设备的机盖时, 应按下表所述连接和断开电缆。

连接时:

1. 关闭所有设备。
2. 首先将所有电缆连接至设备。
3. 将信号电缆连接至接口。
4. 将电源线连接至插座。

断开连接时:

1. 关闭所有设备。
2. 首先从插座中拔出电源线。
3. 从接口上拔下信号电缆。

声明 2



警告:

更换锂电池时，只能使用 IBM 产品号 33F8354 或者是厂商推荐的等同类型的电池。

如果系统模块中含有锂电池，则只能使用同一厂商制造的同一类型的模块进行更换。电池中含有锂，如果使用、拿放或处理不当，可能会发生爆炸。

请勿对电池进行下列操作：
扔入或浸入水电
加热超过 100 (212 F)
进行修理或分解
请按本地法规要求处理电池。

声明 3



警告:

安装激光产品（如 CD-ROM、DVD 驱动器、光纤设备或送话器）时，应注意以下事项：

不要拆除外盖。拆除激光产品的外盖可能会导致激光辐射的危险，本设备中没有用户可维修的部件。

非此处指定的其它控制、调整或与性能有关的操作都有可能导致激光辐射的危险。



危险

某些激光产品中包含内嵌的 3A 级或 3B 级激光二极管。请注意以下事项。

打开时会产生激光辐射。不要直视光束，不要使用光学仪器直接观看光束，避免直接暴露于光束之下。

声明 4



≥18 kg (37 磅)



≥32 kg (70.5 磅)



≥55 kg (121.2 磅)

警告：
抬起时请采用安全操作方法。

声明 5



警告：
使用设备上的电源控制按钮和电源上的开关都不能断开本设备上的电流。
另外，本设备可能带有多条电源线。如要断开设备上的所有电流，请确
保所有电源线均已与电源断开连接。



2



1



声明 6



警告：
如果在电源线连接设备的一端安装了固定松紧夹，则必须将电源线的另一端连接至
使用方便的电源。

声明 7



警告:

如果设备带有外门，则在移动或抬起设备前应将其拆除或固定以避免造成人员伤害。外门支撑不了设备的重量。

声明 8



警告:

不要拆除电源外盖或贴有下列标签的任何部件。



贴有此标签的组件内部存在高电压、高电流的危险。这些组件中没有用户可维修的部件。如果怀疑其中的部件存在问题，应与服务技术人员联系。

声明 9



警告:

为避免人员伤害，拆除设备上的风扇前应拨下热插拔风扇电缆。

声明 10



警告:

机柜安装的设备上面不能放置重于 82kg (180 磅) 的物品。



> 82 kg (180 磅)

声明 11



警告:

下面的标签表明附近有锋利的边、角或接头。



声明 12



警告:

下面的标签表明附近有高热表面。



重要資訊：

Server Library 中所有「注意」及「危險」的聲明均以數字開始。此一數字是用來作為交互參考之用，英文「注意」或「危險」聲明可在本節中找到相同內容的「注意」或「危險」聲明的譯文。

例如，有一「危險」聲明以數字 1 開始，則該「危險」聲明的譯文將出現在本節的「聲明」1 中。

執行任何指示之前，請詳讀所有「注意」及「危險」的聲明。

聲明 1



危險

電源、電話及通信電纜上所產生的電流均有危險性。

欲避免電擊危險：

- 在雷雨期間，請勿連接或切斷本產品上的任何電纜線，或安裝、維修及重新架構本產品。
- 請將電源線接至接線及接地正確的電源插座。
- 請將本產品隨附的設備連接至接線正確的插座。
- 儘可能使用單手來連接或切斷信號電纜線。
- 當設備有火燒或泡水的痕跡，或有結構性損害時，請勿開啓該設備的電源。
- 在安裝及架構之時，若非非常熟悉，在開啓裝置蓋子之前，請切斷電源線、電信系統、網路及數據機。
- 在安裝、移動本產品或附加裝置，或開啓其蓋子時，請依照下表中「連接」及「切斷」電纜線的步驟執行。

連接：

1. 關閉所有開關。
2. 先將所有電纜線接上裝置。
3. 將信號電纜接上接頭。
4. 再將電源線接上電源插座。
5. 開啓裝置的電源。

切斷：

1. 關閉所有開關。
2. 先自電源插座拔掉電源線。
3. 拔掉接頭上的所有信號電纜。
4. 再拔掉裝置上的所有電纜線。

聲明 2



注意：

更換鋰電池時，只可使用 IBM 零件編號 33F8354 的電池，或製造商建議之相當類型的電池。若系統中具有包含鋰電池的模組，在更換此模組時，請使用相同廠商製造的相同模組類型。如未正確使用、處理或丟棄含有鋰的電池時，可能會引發爆炸。

請勿將電池：

- 丟入或浸入水中
- 加熱超過 100 °C (212 °F)
- 修理或拆開

請遵照當地法令規章處理廢棄電池。

聲明 3



注意：

安裝雷射產品(如 CD-ROM、DVD 光碟機、光纖裝置或發射器)時，請注意下列事項：

- 請勿移開蓋子。移開雷射產品的蓋子，您可能會暴露於危險的雷射輻射之下。裝置中沒有需要維修的組件。
- 不依此處所指示的控制、調整或處理步驟，您可能會暴露於危險的輻射之下。



危險

有些雷射產品含有內嵌式 Class 3A 或 Class 3B 雷射二極體。請注意下列事項：

開啓時會產生雷射輻射。請勿凝視光束，不要使用光學儀器直接觀察，且應避免直接暴露在光束下。

聲明 4



≥ 18 公斤 (37 磅) ≥ 32 公斤 (70.5 磅) ≥ 55 公斤 (121.2 磅)

注意：

抬起裝置時，請注意安全措施。

聲明 5



注意：

裝置上的電源控制按鈕及電源供應器上的電源開關均無法關閉裝置上的電流。

本裝置可能有一條以上的電源線。如要移除裝置上的所有電流，請確認所有電源線已與電源分離。



聲明 10



注意：

請勿將任何重量超過 82 公斤 (180 磅) 的物品置於已安裝機架的裝置上方。



>82 公斤 (180 磅)



DANGER

Le courant électrique passant dans les câbles de communication, ou les cordons téléphoniques et d'alimentation peut être dangereux.

Pour éviter tout risque de choc électrique:

- Ne manipulez aucun câble et n'effectuez aucune opération d'installation, d'entretien ou de reconfiguration de ce produit au cours d'un orage.
- Branchez tous les cordons d'alimentation sur un socle de prise de courant correctement câblé et mis à la terre.
- Branchez sur des socles de prise de courant correctement câblés tout équipement connecté à ce produit.
- Lorsque cela est possible, n'utilisez qu'une seule main pour connecter ou déconnecter les câbles d'interface.
- Ne mettez jamais un équipement sous tension en cas d'incendie ou d'inondation, ou en présence de dommages matériels.
- Avant de retirer les carters de l'unité, mettez celle-ci hors tension et déconnectez ses cordons d'alimentation, ainsi que les câbles qui la relient aux réseaux, aux systèmes de télécommunication et aux modems (sauf instruction contraire mentionnée dans les procédures d'installation et de configuration).
- Lorsque vous installez ou que vous déplacez le présent produit ou des périphériques qui lui sont raccordés, reportez-vous aux instructions ci-dessous pour connecter et déconnecter les différents cordons.

Connexion	Déconnexion
1. Mettez les unités hors tension.	1. Mettez les unités hors tension.
2. Commencez par brancher tous les cordons sur les unités.	2. Débranchez les cordons d'alimentation des prises.
3. Branchez les câbles d'interface sur des connecteurs.	3. Débranchez les câbles d'interface des connecteurs.
4. Branchez les cordons d'alimentation sur des prises.	4. Débranchez tous les câbles des unités.
5. Mettez les unités sous tension.	



ATTENTION:

Remplacez la pile au lithium usagée par une pile de référence identique exclusivement - voir la référence IBM - ou par une pile équivalente recommandée par le fabricant. Si votre système est doté d'un module contenant une pile au lithium, vous devez le remplacer uniquement par un module identique, produit par le même fabricant. La pile contient du lithium et présente donc un risque d'explosion en cas de mauvaise manipulation ou utilisation.

- Ne la jetez pas à l'eau.
- Ne l'exposez pas à une température supérieure à 100 °C.

- Ne cherchez pas à la réparer ou à la démonter.

Pour la mise au rebut, reportez-vous à la réglementation en vigueur.



ATTENTION:

Si des produits laser sont installés (tels que des unités de CD-ROM ou de DVD, des périphériques contenant des fibres optiques ou des émetteurs-récepteurs), prenez connaissance des informations suivantes:

- N'ouvrez pas ces produits pour éviter une exposition directe au rayon laser. Vous ne pouvez effectuer aucune opération de maintenance à l'intérieur.
- Pour éviter tout risque d'exposition au rayon laser, respectez les consignes de réglage et d'utilisation des commandes, ainsi que les procédures décrites dans le présent document.



DANGER

Certains produits laser contiennent une diode laser de classe 3A ou 3B. Prenez connaissance des informations suivantes:

Rayonnement laser lorsque le carter est ouvert. évitez de regarder fixement le faisceau ou de l'observer à l'aide d'instruments optiques. évitez une exposition directe au rayon.

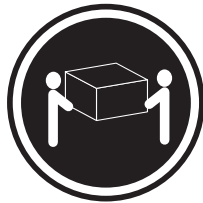

≥18 kg (37 lbs)



≥32 kg (70.5 lbs)

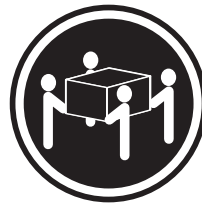

≥55 kg (121.2 lbs)

ATTENTION:

Faites-vous aider pour soulever ce produit.



ATTENTION:

Le bouton de mise sous tension/hors tension de l'unité et l'interrupteur d'alimentation du bloc d'alimentation ne coupent pas l'arrivée de courant

électrique à l'intérieur de la machine. Il se peut que votre unité dispose de plusieurs cordons d'alimentation. Pour isoler totalement l'unité du réseau électrique, débranchez tous les cordons d'alimentation des socles de prise de courant.

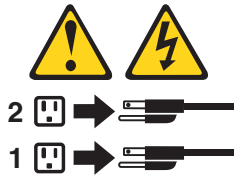

ATTENTION:

Ne posez pas d'objet dont le poids dépasse 82 kg sur les unités montées en armoire.



VORSICHT

Elektrische Spannungen von Netz-, Telefon- und Datenübertragungsleitungen sind gefährlich.

Aus Sicherheitsgründen:

- Bei Gewitter an diesem Gerät keine Kabel anschließen oder lösen. Ferner keine Installations-, Wartungs- oder Rekonfigurationsarbeiten durchführen.
- Gerät nur an eine Schutzkontaktsteckdose mit ordnungsgemäß geerdetem Schutzkontakt anschließen.
- Alle angeschlossenen Geräte ebenfalls an Schutzkontaktsteckdosen mit ordnungsgemäß geerdetem Schutzkontakt anschließen.
- Signalkabel möglichst einhändig anschließen oder lösen.
- Keine Geräte einschalten, wenn die Gefahr einer Beschädigung durch Feuer, Wasser oder andere Einflüsse besteht.
- Die Verbindung zu den angeschlossenen Netzkabeln, Telekommunikationssystemen, Netzwerken und Modems ist vor dem öffnen des Gehäuses zu unterbrechen. Es sei denn, dies ist in den zugehörigen Installations- und Konfigurationsprozeduren anders angegeben.
- Nur nach den nachfolgend aufgeführten Anweisungen arbeiten, die für Installation, Transport oder öffnen von Gehäusen von Personal Computern oder angeschlossenen Einheiten gelten.

Kabel anschließen:	Kabel lösen:
<ol style="list-style-type: none">1. Alle Geräte ausschalten und Netzstecker ziehen.2. Zuerst alle Kabel an Einheiten anschließen.3. Signalkabel an Anschlußbuchsen anschließen.4. Netzstecker an Steckdose anschließen.5. Gerät einschalten.	<ol style="list-style-type: none">1. Alle Geräte ausschalten.2. Zuerst Netzstecker von Steckdose lösen.3. Signalkabel von Anschlußbuchsen lösen.4. Alle Kabel von Einheiten lösen.



ACHTUNG:

Eine verbrauchte Batterie nur durch eine Batterie mit der IBM Teilenummer 33F8354 oder durch eine vom Hersteller empfohlene Batterie ersetzen. Wenn Ihr System ein Modul mit einer Lithium-Batterie enthält, ersetzen Sie es immer mit dem selben Modultyp vom selben Hersteller. Die Batterie enthält Lithium und kann bei unsachgemäßer Verwendung, Handhabung oder Entsorgung explodieren.

Die Batterie nicht:

- mit Wasser in Berührung bringen.
- über 100 C erhitzen.

- reparieren oder zerlegen.

Die örtlichen Bestimmungen für die Entsorgung von Sondermüll beachten.



ACHTUNG:

Wenn ein Laserprodukt (z. B. CD-ROM-Laufwerke, DVD-Laufwerke, Einheiten mit Glasfaserkabeln oder Transmitter) installiert ist, beachten Sie folgendes.

- Das Entfernen der Abdeckungen des CD-ROM-Laufwerks kann zu gefährlicher Laserstrahlung führen. Es befinden sich keine Teile innerhalb des CD-ROM-Laufwerks, die vom Benutzer gewartet werden müssen. Die Verkleidung des CD-ROM-Laufwerks nicht öffnen.
- Steuer- und Einstellelemente sowie Verfahren nur entsprechend den Anweisungen im vorliegenden Handbuch einsetzen. Andernfalls kann gefährliche Laserstrahlung auftreten.



VORSICHT

Manche CD-ROM-Laufwerke enthalten eine eingebaute Laserdiode der Klasse 3A oder 3B. Die nachfolgend aufgeführten Punkte beachten.

Laserstrahlung bei geöffneter Tür. Niemals direkt in den Laserstrahl sehen, nicht direkt mit optischen Instrumenten betrachten und den Strahlungsbereich meiden.

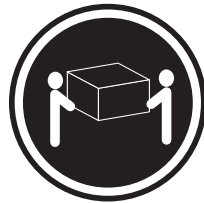

≥18 kg



≥32 kg

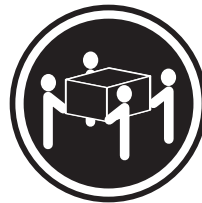

≥55 kg

ACHTUNG:

Beim Anheben der Maschine die vorgeschriebenen Sicherheitsbestimmungen beachten.



ACHTUNG:

Mit dem Betriebsspannungsschalter an der Vorderseite des Servers und dem Betriebsspannungsschalter am Netzteil wird die Stromversorgung für den Server nicht unterbrochen. Der Server könnte auch mehr als ein Netzkabel aufweisen. Um die gesamte Stromversorgung des Servers auszuschalten, muß sichergestellt werden, daß alle Netzkabel aus den Netzsteckdosen herausgezogen wurden.

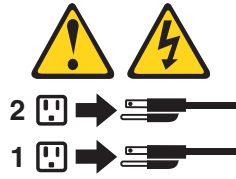

ACHTUNG:



Keine Gegenstände, die mehr als 82 kg wiegen, auf Rack-Einheiten ablegen.



PERICOLO

La corrente elettrica circolante nei cavi di alimentazione, del telefono e di segnale è pericolosa.

Per evitare il pericolo di scosse elettriche:

- Non collegare o scollegare i cavi, non effettuare l'installazione, la manutenzione o la riconfigurazione di questo prodotto durante i temporali.
- Collegare tutti i cavi di alimentazione ad una presa elettrica correttamente cablata e munita di terra di sicurezza.
- Collegare qualsiasi apparecchiatura collegata a questo prodotto ad una presa elettrica correttamente cablata e munita di terra di sicurezza.
- Quando possibile, collegare o scollegare i cavi di segnale con una sola mano.
- Non accendere qualsiasi apparecchiatura in presenza di fuoco, acqua o se sono presenti danni all'apparecchiatura stessa.
- Scollegare i cavi di alimentazione, i sistemi di telecomunicazioni, le reti e i modem prima di aprire i coperchi delle unità, se non diversamente indicato nelle procedure di installazione e configurazione.
- Collegare e scollegare i cavi come descritto nella seguente tabella quando si effettuano l'installazione, la rimozione o l'apertura dei coperchi di questo prodotto o delle unità collegate.

Per collegare:	Per scollegare:
<ol style="list-style-type: none">1. SPEGNERE tutti i dispositivi.2. Collegare prima tutti i cavi alle unità.3. Collegare i cavi di segnale ai connettori.4. Collegare i cavi di alimentazione alle prese elettriche.5. ACCENDERE le unità.	<ol style="list-style-type: none">1. SPEGNERE tutti i dispositivi.2. Rimuovere prima i cavi di alimentazione dalle prese elettriche.3. Rimuovere i cavi di segnale dai connettori.4. Rimuovere tutti i cavi dalle unità.



ATTENZIONE:

Quando si sostituisce la batteria al litio, utilizzare solo una batteria IBM con numero parte 33F8354 o batterie dello stesso tipo o di tipo equivalente consigliate dal produttore. Se il sistema di cui si dispone è provvisto di un modulo contenente una batteria al litio, sostituire tale batteria solo con un tipo di modulo uguale a quello fornito dal produttore. La batteria contiene litio e può esplodere se utilizzata, maneggiata o smaltita impropriamente.

Evitare di:

- Gettarla o immergerla in acqua
- Riscaldarla ad una temperatura superiore ai 100°C
- Cercare di ripararla o smontarla

Smaltire secondo la normativa in vigore (D.Lgs 22 del 5/2/9) e successive disposizioni nazionali e locali.



ATTENZIONE:

Quando si installano prodotti laser come, ad esempio, le unità DVD, CD-ROM, a fibre ottiche o trasmettitori, prestare attenzione a quanto segue:

- Non rimuovere i coperchi. L'apertura dei coperchi di prodotti laser può determinare l'esposizione a radiazioni laser pericolose. All'interno delle unità non vi sono parti su cui effettuare l'assistenza tecnica.
- L'utilizzo di controlli, regolazioni o l'esecuzione di procedure non descritti nel presente manuale possono provocare l'esposizione a radiazioni pericolose.



PERICOLO

Alcuni prodotti laser contengono all'interno un diodo laser di Classe 3A o Classe 3B. Prestare attenzione a quanto segue:

Aperto l'unità vengono emesse radiazioni laser. Non fissare il fascio, non guardarlo direttamente con strumenti ottici ed evitare l'esposizione diretta al fascio.

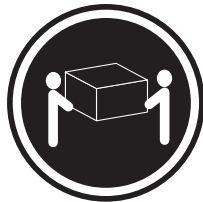

≥18 kg



≥32 kg



≥55 kg

ATTENZIONE:

Durante il sollevamento della macchina seguire delle norme di sicurezza.



ATTENZIONE:

Il pulsante del controllo dell'alimentazione situato sull'unità e l'interruttore di alimentazione posto sull'alimentatore non disattiva la corrente elettrica fornita all'unità. L'unità potrebbe disporre di più di un cavo di alimentazione. Per disattivare la corrente elettrica dall'unità, accertarsi che tutti i cavi di alimentazione

siano scollegati dalla sorgente di alimentazione.

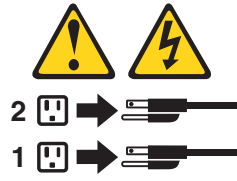

ATTENZIONE:



Non poggiare oggetti che pesano più di 82 kg sulla parte superiore delle unità montate in rack.

중요:

본 *Server Library*에 있는 모든 주의 및 위험 경고문은 번호로 시작합니다. 이 번호는 영문 주의 혹은 위험 경고문과 이 절에 나오는 번역된 버전의 주의 혹은 위험 경고문을 상호 참조하는 데 사용됩니다.

예를 들어, 주의 경고문이 번호 1로 시작하면, 번역된 해당 주의 경고문을 본 절의 경고문 1에서 찾아볼 수 있습니다.

모든 지시사항을 수행하기 전에 반드시 모든 주의 및 위험 경고문을 읽으십시오.

경고문 1



위험

전원, 전하 및 통신 케이블로부터 흘러 나오는 전류는 위험합니다.

전기 충격을 피하려면:

- 뇌우를 동반할 때는 케이블의 연결이나 철수, 이 제품의 설치, 유지보수 또는 재구성을 하지 마십시오.
- 모든 전원 코드를 적절히 배선 및 접지해야 합니다.
- 이 제품에 연결될 모든 장비를 적절하게 배선된 콘센트에 연결하십시오.
- 가능한 한 신호 케이블을 한 손으로 연결하거나 끊으십시오.
- 화재, 수해 또는 구조상의 손상이 있을 경우 장비를 켜지 마십시오.
- 설치 및 구성 프로시저에 다른 설명이 없는 한, 장치 덮개를 열기 전에 연결된 전원 코드, 원격 리 통신 시스템, 네트워크 및 모뎀을 끊어 주십시오.
- 제품 또는 접속된 장치를 설치, 이동 및 덮개를 열 때 다음 설명에 따라 케이블을 연결하거나 끊도록 하십시오.

연결하려면:

1. 모든 스위치를 끕니다.
2. 먼저 모든 케이블을 장치에 연결합니다.
3. 신호 케이블을 커넥터에 연결합니다.
4. 콘센트에 전원 코드를 연결합니다.
5. 장치 스위치를 켭니다.

연결을 끊으려면:

1. 모든 스위치를 끕니다.
2. 먼저 콘센트에서 전원 코드를 뽑습니다.
3. 신호 케이블을 커넥터에서 제거합니다.
4. 장치에서 모든 케이블을 제거합니다.

경고문 2



주의:

리튬 배터리를 교체할 때는 IBM 부품 번호 33F8354 또는 제조업체에서 권장하는 동등한 유형의 배터리를 사용하십시오. 시스템에 리튬 배터리를 갖고 있는 모듈이 있으면 동일한 제조업체에서 생산된 동일한 모듈 유형으로 교체하십시오. 배터리에 리튬이 있을 경우 제대로 사용, 처리 또는 처분하지 않으면 폭발할 수 있습니다.

다음은 주의하십시오.

- 던지거나 물에 담그지 않도록 하십시오.
- 100°C(212°F) 이상으로 가열하지 마십시오.
- 수리하거나 분해하지 마십시오.

지역 법령이나 규정의 요구에 따라 배터리를 처분하십시오.

경고문 3



주의:

레이저 제품(CD-ROMs, DVD 드라이브, 광 장치 또는 트랜스미터 등과 같은)이 설치되어 있을 경우 다음을 유의하십시오.

- 덮개를 제거하지 마십시오. 레이저 제품의 덮개를 제거했을 경우 위험한 레이저 광선에 노출될 수 있습니다. 이 장치 안에는 서비스를 받을 수 있는 부품이 없습니다.

- 여기에서 지정하지 않은 방식의 제어, 조절 또는 실행으로 인해 위험한 레이저 광선에 노출될 수 있습니다.



위험

일부 레이저 제품에는 클래스 3A 또는 클래스 3B 레이저 다이오드가 들어 있습니다. 다음을 주의하십시오.

열면 레이저 광선에 노출됩니다. 광선을 주시하거나 광학 기계를 직접 쳐다보지 않도록 하고 광선에 노출되지 않도록 하십시오.

경고문 4



≥18 kg (37 lbs)



≥ 32 kg (70.5 lbs)



≥ 55 kg (121.2 lbs)

주의:

기계를 들 때는 안전하게 들어 올리십시오.

경고문 5



주의:

장치의 전원 제어 버튼 및 전원 공급기의 전원 스위치는 장치에 공급되는 전류를 차단하지 않습니다. 장치에 둘 이상의 전원 코드가 연결되어 있을 수도 있습니다. 장치에서 모든 전류를 차단하려면 모든 전원 코드가 전원으로부터 차단되어 있는지 확인하십시오.



경고문 10



주의:

서랍형 모델의 장치 상단에 82 kg(180 lbs.)이 넘는 물체를 올려 놓지 마십시오.



>82 kg (180 lbs)



PELIGRO

La corriente eléctrica de los cables telefónicos, de alimentación y de comunicaciones es perjudicial.

Para evitar una descarga eléctrica:

- No conecte ni desconecte ningún cable ni realice las operaciones de instalación, mantenimiento o reconfiguración de este producto durante una tormenta.
- Conecte cada cable de alimentación a una toma de alimentación eléctrica con conexión a tierra y cableado correctos.
- Conecte a tomas de alimentación con un cableado correcto cualquier equipo que vaya a estar conectado a este producto.
- Si es posible, utilice una sola mano cuando conecte o desconecte los cables de señal.
- No encienda nunca un equipo cuando haya riesgos de incendio, de inundación o de daños estructurales.
- Desconecte los cables de alimentación, sistemas de telecomunicaciones, redes y módems conectados antes de abrir las cubiertas del dispositivo a menos que se indique lo contrario en los procedimientos de instalación y configuración.
- Conecte y desconecte los cables tal como se describe en la tabla siguiente cuando desee realizar una operación de instalación, de traslado o de apertura de las cubiertas para este producto o para los dispositivos conectados.

Para la conexión	Para la desconexión
<ol style="list-style-type: none">1. APÁGUELO todo.2. En primer lugar, conecte los cables a los dispositivos.3. Conecte los cables de señal a los conectores.4. Conecte cada cable de alimentación a la toma de alimentación.5. ENCIENDA el dispositivo.	<ol style="list-style-type: none">1. APÁGUELO todo.2. En primer lugar, retire cada cable de alimentación de la toma de alimentación.3. Retire los cables de señal de los conectores.4. Retire los cables de los dispositivos.



PRECAUCIÓN:

Cuando desee sustituir la batería de litio, utilice únicamente el número de pieza 33F8354 de IBM o cualquier tipo de batería equivalente que recomiende el fabricante. Si el sistema tiene un módulo que contiene una batería de litio, sustitúyalo únicamente por el mismo tipo de módulo, que ha de estar creado por el mismo fabricante. La batería contiene litio y puede explotar si el usuario no la utiliza ni la maneja de forma adecuada o si no se desprende de la misma como corresponde.

No realice las acciones siguientes:

- Arrojarla al agua o sumergirla

- Calentarla a una temperatura que supere los 100°C (212°F)
- Repararla o desmontarla

Despréndase de la batería siguiendo los requisitos que exija el reglamento o la legislación local.



PRECAUCIÓN:

Cuando instale productos láser (como, por ejemplo, CD-ROM, unidades DVD, dispositivos de fibra óptica o transmisores), tenga en cuenta las advertencias siguientes:

- No retire las cubiertas. Si retira las cubiertas del producto láser, puede quedar expuesto a radiación láser perjudicial. Dentro del dispositivo no existe ninguna pieza que requiera mantenimiento.
- El uso de controles o ajustes o la realización de procedimientos que no sean los que se han especificado aquí pueden dar como resultado una exposición perjudicial a las radiaciones.



PELIGRO

Algunos productos láser contienen un diodo de láser incorporado de Clase 3A o de Clase 3B. Tenga en cuenta la advertencia siguiente.

Cuando se abre, hay radiación láser. No mire fijamente el rayo ni lleve a cabo ningún examen directamente con instrumentos ópticos; evite la exposición directa al rayo.



≥18 kg



≥32 kg

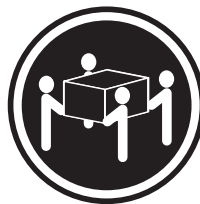

≥55 kg

PRECAUCIÓN:

Tome medidas de seguridad al levantar el producto.



PRECAUCIÓN:

El botón de control de alimentación del dispositivo y el interruptor de alimentación de la fuente de alimentación no apagan la corriente eléctrica suministrada al dispositivo. Es posible también que el dispositivo tenga más de un cable de alimentación. Para eliminar la corriente eléctrica del dispositivo, asegúrese de desconectar todos los cables de alimentación de la fuente de alimentación.



PRECAUCIÓN:



No coloque ningún objeto que pese más de 82 kg (180 libras) encima de los dispositivos montados en bastidor.

Send us your comments!

We want to know your opinion about this manual (part number 24P2934). Your input will help us to improve our publications.

Please photocopy this survey, complete it, and then fax it to **IBM HMM Survey** at **919-543-8167 (USA)**.

Name: _____

Phone number: _____

1. Do you like this manual?

Yes No

2. What would you like to see added, changed, or deleted in this manual?

3. What is your service experience level?

Less than five years

More than five years

4. Which computers do you service most?

Thank you for your response!

Problem determination tips

Due to the variety of hardware and software combinations that can be encountered, use the following information to assist you in problem determination. If possible, have this information available when requesting assistance from Service Support and Engineering functions.

- Machine type and model
- Processor or hard disk upgrades
- Failure symptom
 - Do diagnostics fail?
 - What, when, where, single, or multiple systems?
 - Is the failure repeatable?
 - Has this configuration ever worked?
 - If it has been working, what changes were made prior to it failing?
 - Is this the original reported failure?
- Reference/Diagnostics version
 - Type and version level
- Hardware configuration
 - Print (print screen) configuration currently in use
 - BIOS level
- Operating system software
 - Type and version level

Note: To eliminate confusion, identical systems are considered identical only if they:

1. Are the exact machine type and models
2. Have the same BIOS level
3. Have the same adapters/attachments in the same locations
4. Have the same address jumpers/terminators/cabling
5. Have the same software versions and levels
6. Have the same Reference/Diagnostics Diskette (version)
7. Have the same configuration options set in the system
8. Have the same setup for the operation system control files

Comparing the configuration and software set-up between "working and non-working" systems will often lead to problem resolution.

Notices

References in this publication to IBM products, programs, or services do not imply that IBM intends to make these available in all countries in which IBM operates. Any reference to an IBM product, program, or service is not intended to state or imply that only that IBM product, program, or service may be used. Subject to IBM's valid intellectual property or other legally protectable rights, any functionally equivalent product, program, or service may be used instead of the IBM product, program, or service. The evaluation and verification of operation in conjunction with other products, except those expressly designated by IBM, are the responsibility of the user.

Trademarks

The following terms are trademarks of the IBM Corporation in the United States, other countries, or both:

Alert on LAN	OS/2 Warp
EtherJet	ServeRAID
e-business logo	ServerGuide
HelpCenter	ServerProven
HelpWare	TechConnect
IBM	Tivoli
OS/2	Update Connector
NetView	Wake on LAN
NetVista	

Lotus and Domino are trademarks of Lotus Development Corporation in the United States, other countries, or both.

Intel and Celeron are registered trademarks of Intel Corporation.

Microsoft, Windows, and Windows NT are trademarks of Microsoft Corporation in the United States, other countries, or both.

UNIX is a registered trademark of The Open Group in the United States and other countries.

Java and all Java-based trademarks and logos are trademarks or registered trademarks of Sun Microsystems, Inc. in the United States, other countries, or both.

Other company, product, and service names may be trademarks or service marks of others.



Part Number: 24P2971

