



Unidad ThinkPad
CD-RW/DVD-ROM Combo III
Ultrabay 2000

Guía del usuario



Unidad ThinkPad
CD-RW/DVD-ROM Combo III
Ultrabay 2000

Guía del usuario

ATENCIÓN

Antes de instalar este producto, lea la *Información de seguridad* del sistema ThinkPad.

Nota

No olvide guardar el comprobante de compra, porque tal vez lo necesite para obtener los servicios de garantía. Consulte el Apéndice A, "Warranty Information" en la página 13.

Primera edición (Septiembre 2002)

Este manual es la traducción del original inglés *ThinkPad CD-RW/DVD-ROM Combo III Ultrabay 2000 Drive User's Guide*.

© Copyright International Business Machines Corporation 2002. Reservados todos los derechos.

Contenido

Seguridad: Leer primero	v
Capítulo 1. Acerca de la unidad de CD-RW/DVD	1
Registro del producto	1
Descripción del producto	1
Requisitos de la instalación	2
Instalación de la unidad	2
Ubicación de los controles de la unidad	3
Capítulo 2. Utilización de la unidad de CD-RW/DVD	5
Antes de empezar	5
Manejo y cuidado de un disco	5
Cuidado de la unidad CD-RW/DVD	6
Carga de un disco	7
Expulsión manual de un disco	7
Utilización de la función de DVD	7
Habilitación del valor DMA	8
Instalación de WinDVD y visualización de una película en DVD	9
Cómo iniciar WinDVD.	10
Utilización de la función de CD-R y de CD-RW	10
Copia de seguridad de un CD	11
Resolución de problemas	11
Apéndice A. Warranty Information	13
Warranty period.	13
Service and support	13
Warranty information on the World Wide Web	13
Online technical support	13
Telephone technical support.	14
IBM Statement of Limited Warranty Z125-4753-06 8/2000	15
Part 1 - General Terms.	15
Part 2 - Country-unique Terms	18
Apéndice B. Notices	27
Trademarks	28
Electronic emission notices	28

Seguridad: Leer primero

Before installing this product, read the Safety Information.

مج، يجب قراءة دات السلامة

Antes de instalar este produto, leia as Informações de Segurança.

在安装本产品之前，请仔细阅读 **Safety Information**
(安全信息)。

Prije instalacije ovog produkta obavezno pročitajte Sigurnosne Upute.

Před instalací tohoto produktu si přečtete příručku bezpečnostních instrukcí.

Læs sikkerhedsforskrifterne, før du installerer dette produkt.

Ennen kuin asennat tämän tuotteen, lue turvaohjeet kohdasta Safety Information.

Avant d'installer ce produit, lisez les consignes de sécurité.

Vor der Installation dieses Produkts die Sicherheitshinweise lesen.

Πριν εγκαταστήσετε το προϊόν αυτό, διαβάστε τις πληροφορίες ασφάλειας (safety information).

פני שתתקינו מוצר זה, קראו את הוראות הבטיחות.

A termék telepítése előtt olvassa el a Biztonsági előírásokat!

Prima di installare questo prodotto, leggere le Informazioni sulla Sicurezza.

製品の設置の前に、安全情報をお読みください。

본 제품을 설치하기 전에 안전 정보를 읽으십시오.

Пред да се инсталира овој продукт, прочитајте информацијата за безбедност.

Lees voordat u dit product installeert eerst de veiligheidsvoorschriften.

Les sikkerhetsinformasjonen (Safety Information) før du installerer dette produktet.

Przed zainstalowaniem tego produktu, należy zapoznać się z książką "Informacje dotyczące bezpieczeństwa" (Safety Information).

Antes de instalar este produto, leia as Informações sobre Segurança.

Перед установкой продукта прочтите инструкции по технике безопасности.

Pred inštaláciou tohto zariadenia si pečítajte Bezpečnostné predpisy.

Pred namestitvijo tega proizvoda preberite Varnostne informacije.

Antes de instalar este producto lea la información de seguridad.

Läs säkerhetsinformationen innan du installerar den här produkten.

安裝本產品之前，請先閱讀「安全資訊」。

Capítulo 1. Acerca de la unidad de CD-RW/DVD

En este manual se proporciona información sobre el registro, la instalación y la utilización de la Unidad IBM ThinkPad CD-RW/DVD-ROM Combo III Ultrabay 2000. Está disponible en el *Software and User's Guide CD* en los siguientes idiomas:

- Inglés
- Francés
- Alemán
- Italiano
- Japonés
- Español
- Portugués de Brasil
- Chino simplificado
- Chino tradicional

Los apéndices de esta guía contienen información sobre la garantía y avisos legales.

Registro del producto

Gracias por adquirir este producto IBM. Tómese la molestia de registrar el producto y de facilitarnos información que nos permitirá atenderle mejor en el futuro. Su opinión nos ayudará a desarrollar mejores productos y servicios, así como mejores formas de comunicarnos con usted. Registre su opción en el sitio web de IBM <http://www.ibm.com/pc/register/>.

Recibirá información y actualizaciones del producto registrado a no ser que, en el sitio web, indique que no desea recibir más información.

Descripción del producto

La CD-RW/DVD-ROM Combo III Ultrabay 2000 Drive del sistema ThinkPad de IBM puede grabar y leer discos CD-RW y CD-R (CD grabable), así como leer CD y DVD grabados y fabricados en serie. Esta unidad también puede leer soportes DVD-RAM, DVD-R y DVD-RW formateados.

La unidad graba en discos CD-R y CD-RW a distintas velocidades. El soporte de CD-R se puede grabar a una velocidad máxima de 16X, mientras que el soporte de CD-RW se puede grabar y regrabar a una velocidad máxima de 10X. El soporte de CD se puede leer a una velocidad máxima de 24X, mientras que el soporte de DVD se puede leer a una velocidad máxima de 8X. Esta

unidad también dispone de la función de protección contra la pérdida de datos por defecto del almacenamiento intermedio, lo cual ayuda a minimizar los errores de grabación.

Además de este manual, debe de haber recibido el siguiente material:

- Unidad de CD-RW/DVD
- Maletín portátil
- *Software and User's Guide CD*
- *Laser Safety Guide*
- *Quick Reference Guide*

Nota: Es posible que el kit también contenga un disquete de actualizaciones para el software de IBM DVD o de IBM CD-RW.

Póngase en contacto con la tienda donde ha adquirido el producto en caso de que falte un elemento o de que esté dañado. No olvide guardar el comprobante de compra. Tal vez lo necesite para recibir el servicio de garantía. Para obtener información sobre el servicio técnico, consulte la sección "Service and support" en la página 13.

Requisitos de la instalación

Para instalar la unidad CD-RW/DVD, el sistema ThinkPad debe contener los siguientes requisitos:

- Una bahía de unidad Ultrabay 2000, unidad de expansión ThinkPad, ThinkPad dispositivo de soportes UltraBase X2, IBM Portable Drive Bay 2000 o IBM ThinkPad X3 UltraBase
- Sistema operativo Windows XP o Windows 2000

Notas:

1. IBM ofrece soporte limitado a sistemas con Windows 95, 98, ME o NT.
2. El sistema ThinkPad A21e no permite reproducir DVD bajo Windows NT.

Instalación de la unidad

El sistema ThinkPad incluye un sistema de ayuda, Access ThinkPad, que proporciona instrucciones específicas de instalación de la unidad en el sistema. Para instalar la unidad CD-RW/DVD en la bahía de unidad Ultrabay 2000, siga las instrucciones que se indican en el sistema de ayuda de Access para ThinkPad.

Ubicación de los controles de la unidad

El diagrama siguiente muestra la ubicación de los controles situados en la parte frontal de la unidad.

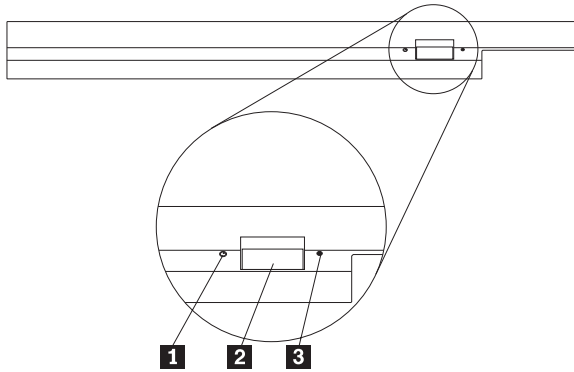

1 Indicador de encendido

Este indicador luminoso es visible cuando se utiliza la unidad.

2 Botón de expulsión

Pulse este botón para expulsar un DVD o un CD.

3 Orificio de expulsión manual

Utilice este sistema de expulsión de emergencia para expulsar un DVD o un CD cuando el botón de expulsión no funcione. Si desea obtener más información sobre cómo expulsar manualmente un DVD o un CD, consulte el apartado “Expulsión manual de un disco” en la página 7.

Capítulo 2. Utilización de la unidad de CD-RW/DVD

En esta sección se proporciona información sobre cómo manejar, cargar y cuidar los DVD y los CD, así como información sobre cómo cuidar la unidad CD-RW/DVD.

Antes de empezar

Para obtener los mejores resultados, revise las siguientes directrices antes de utilizar la unidad:

- No mueva el sistema ThinkPad mientras esté formateando o grabando un disco, puesto que podrían producirse errores de datos. Asimismo, minimice las acciones de tecleo mientras formatea o graba un disco, ya que esto también podría producir errores de datos.
- Mantenga el sistema ThinkPad en una superficie plana cuando grave en un disco.
- Asegúrese de que el sistema ThinkPad esté enchufado a la toma de alimentación de CA cuando utilice la unidad. Es posible que el disco se dañe si la batería se agota mientras está grabando en un disco.
- Desactive los protectores de pantalla. El uso de un protector de pantalla podría interrumpir el proceso de formato y grabación.
- No ponga el sistema ThinkPad en modalidad de hibernación o suspensión mientras graba en un disco.

Nota: Los resultados de lectura y grabación de la unidad dependen de la calidad y las características de los soportes DVD o CD utilizados.

Manejo y cuidado de un disco

Maneje y limpie con cuidado los discos, en especial los tipos de soporte grabables, como por ejemplo, los discos CD-R y CD-RW, para que puedan seguir leyéndose. Si toma las siguientes precauciones, puede prolongar la vida de sus discos:

<p>Atención: Si limpia un disco realizando movimientos circulares, se pueden perder datos.</p>

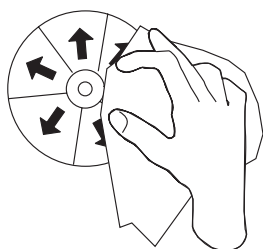
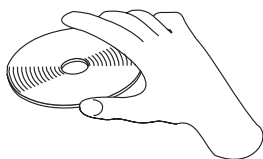

- Sujete el disco por los bordes o por el orificio central. No toque la superficie de un disco.
- Para eliminar el polvo o las huellas dactilares, limpie el disco desde el centro hacia afuera con un paño suave que no tenga pelusa.
- No escriba en la superficie de un disco.
- No exponga un disco a la luz directa del sol.
- No utilice productos de limpieza comerciales para limpiar un disco.
- No doble un disco.

Cuidado de la unidad CD-RW/DVD

Para proteger la unidad durante las operaciones, tome las siguientes precauciones:

- Extraiga el disco de la unidad antes de moverla.
- No inserte objetos extraños en la unidad.
- No apile objetos en la unidad.
- No extraiga la cubierta de la unidad ni intente arreglarla.
- No realice operaciones en la unidad en ninguna de las situaciones siguientes:
 - Alta temperatura, alta humedad o luz solar directa
 - Vibraciones excesivas, golpes bruscos o superficie inclinada
 - Polvo excesivo

Carga de un disco

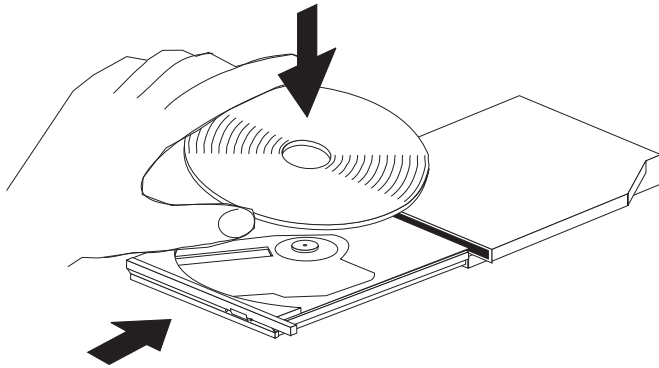

1. Pulse el botón de expulsión. La bandeja se desliza afuera de la unidad.
2. Coloque un disco en la bandeja con la etiqueta boca arriba.
3. Cierre la bandeja, empujándola suavemente hacia adentro hasta que quede completamente cerrada.

Atención: No emplee la fuerza ni inserte objetos extraños para abrir la bandeja. Si la bandeja no se abre cuando pulse el botón de expulsión, consulte la sección "Expulsión manual de un disco" para obtener más información.

Expulsión manual de un disco

Si pulsa el botón de expulsión y la bandeja no se desliza hacia afuera, apague el sistema y enderece un clip sujetapapeles largo para utilizarlo a modo de herramienta, tal como se muestra en la figura. El extremo enderezado debe tener una extensión mínima de 45 mm (1,8 pulgadas). Inserte el extremo extendido en el orificio de expulsión manual situado en la parte frontal de la unidad. Ejercer presión con el clip sujetapapeles hasta que se abra la bandeja. Estire suavemente de la bandeja hasta que pueda extraer el disco.

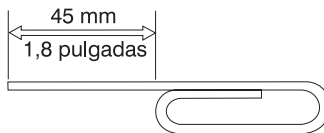

Utilización de la función de DVD

Para utilizar la función de DVD, debe configurar el sistema de la siguiente forma después de haber instalado la unidad CD-RW/DVD en la bahía de la unidad Ultrabay 2000:

1. Active el valor DMA (sólo para usuarios de Windows 98, Windows 95 y Windows 2000).
2. Instale WinDVD (el programa para reproducir películas DVD).

Nota: En Windows 95, el reproductor de películas DVD recibe soporte en Windows 95 OSR2.0 o en versiones posteriores. Para comprobar qué versión de Windows 95 está utilizando, realice las acciones siguientes:

1. Pulse el botón **Inicio**, mueva el cursor hasta **Configuración** y, a continuación, pulse el botón **Panel de control**.
2. Efectúe una doble pulsación sobre **Sistema**.
Lea los números que figuran debajo de "Sistema".
 - 4.00.950B indica que su versión es Windows 95 OSR2.0 ó OSR2.1.
 - 4.00.950C indica que su versión es Windows 95 OSR2.5.

Habilitación del valor DMA

Esta sección se aplica a Windows 95, Windows 98 y Windows 2000. Vaya a la sección correspondiente:

- "Para Windows 95 y Windows 98"
- "Para Windows 2000"

Para Windows 95 y Windows 98

1. Pulse el botón **Inicio**, mueva el cursor hasta **Configuración** y, a continuación, pulse el botón **Panel de control**.
2. Efectúe una doble pulsación sobre **Sistema**.
3. Pulse **Administrador de dispositivos**.
4. Efectúe una doble pulsación sobre el icono **CDROM**. El nombre de la unidad CD-RW/DVD aparece debajo del icono **CDROM**.
5. Efectúe una doble pulsación sobre el nombre de la unidad.
6. Pulse la pestaña **Configuración**.
7. Marque los recuadros de selección **DMA** y **Notificar la inserción automáticamente**. Si se abre la ventana de alerta, pulse **Aceptar** para cerrarla.
8. Pulse **Aceptar**.
9. Pulse **Cerrar** para cerrar la ventana Propiedades del sistema. Aparece un mensaje informándole de que la configuración del sistema ha cambiado.
10. Pulse **Aceptar** para reiniciar el sistema.

Para Windows 2000

1. Pulse el botón **Inicio**, mueva el cursor hasta **Configuración** y, a continuación, pulse el botón **Panel de control**.
2. Efectúe una doble pulsación sobre **Sistema**.

3. Pulse la pestaña **Hardware**.
4. Pulse el botón **Administrador de dispositivos**.
5. Pulse **Controlador IDE ATA/ATAPI** para que se despliegue el submenú.
6. Efectúe una doble pulsación sobre **IDE secundario**. (Realice una doble pulsación en **IDE primario** si utiliza el sistema ThinkPad A21e.)
7. Seleccione **DMA está disponible** como Modo de transferencia.
8. Pulse **Aceptar**.
9. Pulse **Cerrar** para cerrar la ventana Propiedades del sistema. Aparece un mensaje informándole de que la configuración del sistema ha cambiado.
10. Pulse **Aceptar** para reiniciar el sistema.

Instalación de WinDVD y visualización de una película en DVD

Para instalar WinDVD, vaya a la sección "Software" del *Software and User's Guide CD*.

Una vez instalados la unidad unidad CD-RW/DVD y el programa WinDVD, puede ver una película DVD. Sin embargo, es necesario que establezca primero el código de región de DVD correspondiente al contenido del DVD.

Códigos de región de DVD

Los códigos de región de DVD ayudan a proteger el contenido de un DVD. El mundo está dividido en seis regiones, de tal manera que el contenido específico sólo se puede ver en la región pertinente. Por ejemplo, el contenido para la Región 1 se puede ver únicamente en los Estados Unidos y en Canadá. WinDVD también es específico de determinadas regiones.

Puede verificar el código de región del contenido examinando el símbolo de código de la región situado en la parte posterior del embalaje del contenido.

Código de región	Región
1	EE.UU, Canadá
2	Europa, Oriente medio, Sudáfrica, Japón
3	Sudeste asiático, Taiwán, Corea
4	Latinoamérica, Australia, Nueva Zelanda
5	Ex Unión Soviética, África del Norte, India
6	República Popular de China

Inicie WinDVD insertando el DVD en la unidad. El código de región se establece automáticamente, lo cual permite ver la película. Éste es el valor inicial.

Una vez el código de región se haya establecido, si inserta un DVD con un código de región distinto, se le solicitará si desea cambiar el código de región. Puede cambiar el código de región respecto al valor inicial hasta un máximo de cuatro veces.

Una vez cambiado el código de región respecto al valor inicial cuatro veces, dicho código quedará fijo y ya no se podrá cambiar. Por consiguiente, sólo podrá reproducir el contenido del DVD de esa región.

Para visualizar el estado del código de región, pulse el botón **WinDVD Properties** en la interfaz de usuario de WinDVD. La pestaña **General** contiene esta información.

Cómo iniciar WinDVD

Para iniciar WinDVD, lleve a cabo el siguiente procedimiento:

1. Pulse el botón **Inicio**.
2. Pulse el botón **Programas**.
3. Pulse el botón **InterVideo WinDVD**.
4. Pulse el botón **InterVideo WinDVD** par abrir la ventana del reproductor de películas en DVD.

Si desea obtener más información sobre cómo poner en funcionamiento el reproductor de películas en DVD, consulte la información de ayuda sobre WinDVD en el *Software and User's Guide CD*. Si desea ver una película DVD en su televisor, consulte la información en línea que se proporciona con el sistema.

Notas:

1. Su sistema se ha configurado para proporcionar la calidad de reproducción de audio y vídeo más alta posible con los recursos del sistema disponibles. Puede modificar los valores predeterminados cambiando el valor de resolución de vídeo en el Panel de control. Algunos sistemas no disponen de suficientes recursos para proporcionar una reproducción de audio y vídeo de calidad completa con todos los valores de resolución. Si detecta un rendimiento de reproducción deficiente, ajuste la resolución a un valor más bajo.
2. Las corrientes de datos de audio o vídeo se descodifican mediante el software. Los sistemas de audio y vídeo han funcionar y estar totalmente habilitados.

Utilización de la función de CD-R y de CD-RW

La unidad CD-RW/DVD puede grabar tanto en los discos CD-R como los discos CD-RW. Los discos CD-R no se pueden borrar, pero se pueden utilizar con las unidades de CD-ROM y reproductores de CD estándar.

Puede utilizar discos CD-R para grabar pistas de audio, almacenar datos, archivar archivos y copiar archivos desde otro CD.

Los discos CD-RW se pueden borrar y volver a grabar, pero sólo se pueden utilizar con unidades de CD-ROM y DVD-ROM compatibles con discos CD-RW y MR más recientes. Puede utilizar los discos CD-RW para efectuar copias de seguridad, almacenar y actualizar archivos o para copiar archivos desde otro CD.

Notas:

1. Los discos CD-R se pueden reproducir en reproductores de CD de audio. Los discos CD-RW no se pueden reproducir en la mayoría de los reproductores de CD de audio.
2. El software que se incluye con esta unidad **no** habilita las funciones de grabación de CD con los sistemas operativos DOS, Windows 3.x o IBM OS/2®.

Si desea obtener más información sobre cómo utilizar el software, consulte la información de ayuda de IBM RecordNow y de IBM DLA del *Software and User's Guide CD*.

Copia de seguridad de un CD

Para copiar un CD comercial, debe poseer los derechos de autor (copyright) u obtener permiso del titular del copyright. Si no posee derechos de autor o no obtiene permiso del titular de los mismos, puede que esté violando la legislación de derechos de autor y deba pagar daños u otros perjuicios. Para más información sobre la ley de derechos de autor, consulte a su asesor legal.

Resolución de problemas

Los problemas del sistema pueden ser debidos al hardware, al software o a un error del usuario. La información de esta sección puede servirle de ayuda para solucionar problemas o para reunir información útil que pueda suministrar a un técnico de servicio. Asimismo, tal vez sea conveniente que consulte las publicaciones del sistema, del sistema operativo o del adaptador de sonido.

Revise la siguiente lista para cualquier descripción de problema que pueda adaptarse a su caso.

No puede crear un disco multisesión.

Asegúrese de que queda suficiente espacio en el disco para otra sesión. Si graba una sesión, necesitará espacio de entrada y salida adicional (cerca de 15 MB) además de los datos que se graban.

No puede grabar con éxito en un disco CD-R o CD-RW.

Emprenda las acciones siguientes:

1. Verifique si el proceso no lo está interrumpiendo un protector de pantalla, un programa antivirus, un programa de Internet o de correo electrónico, o bien otro software. Inhabilite las funciones que puedan interrumpir la operación de grabación.
2. Verifique si el disco duro está desfragmentado.
3. Consulte al fabricante o proveedor de la unidad de disco duro, si una unidad de disco duro más antigua está efectuando una recalibración térmica durante una operación de grabación.
4. Sustituya el CD, en caso de que sea defectuoso o está rayado.
5. Inhabilite la función Notificar la inserción automáticamente de Windows en las unidades de CD-ROM y de CD-RW.

No puede expulsar un CD.

Realice las siguientes acciones después de comprobar que la unidad no esté grabándose en un disco:

1. Expulse el CD mediante el software.
2. Utilice el botón de expulsión.
3. Apague el sistema. Espere 45 segundos; a continuación, encienda el sistema e intente utilizar de nuevo el botón de expulsión.
4. Si otros métodos no funcionan, utilice el orificio de expulsión manual, siguiendo las instrucciones que se indican en la sección "Expulsión manual de un disco" en la página 7.

No puede leer el CD después de haber grabado con éxito en él.

Emprenda las acciones siguientes:

1. Si puede leer el CD en otro reproductor de CD o puede ver las sesiones anteriores, puede que la información del directorio esté dañada en el volumen, y por consiguiente, sea ilegible. Para obtener ideas para resolver los problemas, consulte la documentación que se suministra con el software.
2. Tal vez tenga un disco CD-R o CD-RW dañado. Intente un disco CD-R o CD-RW nuevo o bien, otra marca de CD.
3. Si puede leer desde un disco CD-RW en la unidad de grabación, pero no puede hacerlo en otra unidad MR, asegúrese de que el sistema tiene instalado un programa Lector de UDF.
4. Evite grabar a la velocidad 1X más lenta, a menos que se lo indique el sistema.

Apéndice A. Warranty Information

This section contains the warranty period for your product, information about obtaining warranty service and support, and the IBM Statement of Limited Warranty.

Warranty period

Contact your place of purchase for warranty service information. Some IBM Machines are eligible for on-site warranty service depending on the country or region where service is performed.

Machine - IBM ThinkPad CD-RW/DVD-ROM Combo III Ultrabay 2000 Drive

Warranty period - One year

Service and support

The following information describes the technical support that is available for your product, during the warranty period or throughout the life of the product. Refer to your IBM Statement of Limited Warranty for a full explanation of IBM warranty terms.

Warranty information on the World Wide Web

The IBM Machine Warranties Web site at http://www.ibm.com/servers/support/machine_warranties/ contains a worldwide overview of the IBM Limited Warranty for IBM Machines, a glossary of terms used in the Statement of Limited Warranty, Frequently Asked Questions (FAQ), and links to Product Support Web pages. The IBM Statement of Limited Warranty is available from this Web site in 29 languages in Portable Document Format (PDF).

Online technical support

Online technical support is available during the life of your product through the Personal Computing Support Web site at <http://www.ibm.com/pc/support/>.

During the warranty period, assistance for replacement or exchange of defective components is available. In addition, if your IBM option is installed in an IBM computer, you might be entitled to service at your location. Your technical support representative can help you determine the best alternative.

Telephone technical support

Installation and configuration support through the IBM HelpCenter® will be withdrawn or made available for a fee, at IBM's discretion, 90 days after the option has been withdrawn from marketing. Additional support offerings, including step-by-step installation assistance, are available for a nominal fee.

To assist the technical support representative, have available as much of the following information as possible:

- Option name
- Option number
- Proof of purchase
- Computer manufacturer, model, serial number (if IBM), and manual
- Exact wording of the error message (if any)
- Description of the problem
- Hardware and software configuration information for your system

If possible, be at your computer. Your technical support representative might want to walk you through the problem during the call.

For the support telephone number and support hours by country, refer to the following table. If the number for your country or region is not listed, contact your IBM reseller or IBM marketing representative. Response time may vary depending on the number and nature of the calls received.

Support 24 hours a day, 7 days a week	
Canada (Toronto only)	416-383-3344
Canada (all other)	1-800-565-3344
U.S.A. and Puerto Rico	1-800-772-2227
All other countries and regions	Go to http://www.ibm.com/pc/support/ , and click Support Phone List .

IBM Statement of Limited Warranty Z125-4753-06 8/2000

Part 1 - General Terms

This Statement of Limited Warranty includes Part 1 - General Terms and Part 2 - Country-unique Terms. The terms of Part 2 replace or modify those of Part 1. The warranties provided by IBM in this Statement of Limited Warranty apply only to Machines you purchase for your use, and not for resale, from IBM or your reseller. The term "Machine" means an IBM machine, its features, conversions, upgrades, elements, or accessories, or any combination of them. The term "Machine" does not include any software programs, whether pre-loaded with the Machine, installed subsequently or otherwise. Unless IBM specifies otherwise, the following warranties apply only in the country where you acquire the Machine. Nothing in this Statement of Limited Warranty affects any statutory rights of consumers that cannot be waived or limited by contract. If you have any questions, contact IBM or your reseller.

The IBM Warranty for Machines: IBM warrants that each Machine 1) is free from defects in materials and workmanship and 2) conforms to IBM's Official Published Specifications ("Specifications"). The warranty period for a Machine is a specified, fixed period commencing on its Date of Installation. The date on your sales receipt is the Date of Installation unless IBM or your reseller informs you otherwise.

If a Machine does not function as warranted during the warranty period, and IBM or your reseller are unable to either 1) make it do so or 2) replace it with one that is at least functionally equivalent, you may return it to your place of purchase and your money will be refunded.

Extent of Warranty: The warranty does not cover the repair or exchange of a Machine resulting from misuse, accident, modification, unsuitable physical or operating environment, improper maintenance by you, or failure caused by a product for which IBM is not responsible. The warranty is voided by removal or alteration of Machine or parts identification labels.

THESE WARRANTIES ARE YOUR EXCLUSIVE WARRANTIES AND REPLACE ALL OTHER WARRANTIES OR CONDITIONS, EXPRESS OR IMPLIED, INCLUDING, BUT NOT LIMITED TO, THE IMPLIED WARRANTIES OR CONDITIONS OF MERCHANTABILITY AND FITNESS FOR A PARTICULAR PURPOSE. THESE WARRANTIES GIVE YOU SPECIFIC LEGAL RIGHTS AND YOU MAY ALSO HAVE OTHER RIGHTS WHICH VARY FROM JURISDICTION TO JURISDICTION. SOME JURISDICTIONS DO NOT ALLOW THE EXCLUSION OR LIMITATION OF EXPRESS OR IMPLIED WARRANTIES, SO THE ABOVE EXCLUSION OR LIMITATION MAY NOT APPLY TO YOU. IN THAT EVENT, SUCH WARRANTIES ARE LIMITED IN DURATION TO THE WARRANTY PERIOD. NO WARRANTIES APPLY AFTER THAT PERIOD.

Items Not Covered by Warranty: IBM does not warrant uninterrupted or error-free operation of a Machine. Any technical or other support provided for a Machine under warranty, such as assistance via telephone with “how-to” questions and those regarding Machine set-up and installation, will be provided **WITHOUT WARRANTIES OF ANY KIND.**

Warranty Service: To obtain warranty service for a Machine, contact IBM or your reseller. If you do not register your Machine with IBM, you may be required to present proof of purchase.

During the warranty period, IBM or your reseller, if approved by IBM to provide warranty service, provides without charge certain types of repair and exchange service to keep Machines in, or restore them to, conformance with their Specifications. IBM or your reseller will inform you of the available types of service for a Machine based on its country of installation. At its discretion, IBM or your reseller will 1) either repair or exchange the failing Machine and 2) provide the service either at your location or a service center. IBM or your reseller will also manage and install selected engineering changes that apply to the Machine.

Some parts of IBM Machines are designated as Customer Replaceable Units (called “CRUs”), e.g., keyboards, memory, or hard disk drives. IBM ships CRUs to you for replacement by you. You must return all defective CRUs to IBM within 30 days of your receipt of the replacement CRU. You are responsible for downloading designated Machine Code and Licensed Internal Code updates from an IBM Internet Web site or from other electronic media, and following the instructions that IBM provides.

When warranty service involves the exchange of a Machine or part, the item IBM or your reseller replaces becomes its property and the replacement becomes yours. You represent that all removed items are genuine and unaltered. The replacement may not be new, but will be in good working order and at least functionally equivalent to the item replaced. The replacement assumes the warranty service status of the replaced item. Many features, conversions, or upgrades involve the removal of parts and their return to IBM. A part that replaces a removed part will assume the warranty service status of the removed part.

Before IBM or your reseller exchanges a Machine or part, you agree to remove all features, parts, options, alterations, and attachments not under warranty service.

You also agree to

1. ensure that the Machine is free of any legal obligations or restrictions that prevent its exchange;

2. obtain authorization from the owner to have IBM or your reseller service a Machine that you do not own; and
3. where applicable, before service is provided:
 - a. follow the problem determination, problem analysis, and service request procedures that IBM or your reseller provides;
 - b. secure all programs, data, and funds contained in a Machine;
 - c. provide IBM or your reseller with sufficient, free, and safe access to your facilities to permit them to fulfill their obligations; and
 - d. inform IBM or your reseller of changes in a Machine's location.

IBM is responsible for loss of, or damage to, your Machine while it is 1) in IBM's possession or 2) in transit in those cases where IBM is responsible for the transportation charges.

Neither IBM nor your reseller is responsible for any of your confidential, proprietary or personal information contained in a Machine which you return to IBM or your reseller for any reason. You should remove all such information from the Machine prior to its return.

Limitation of Liability: Circumstances may arise where, because of a default on IBM's part or other liability, you are entitled to recover damages from IBM. In each such instance, regardless of the basis on which you are entitled to claim damages from IBM (including fundamental breach, negligence, misrepresentation, or other contract or tort claim), except for any liability that cannot be waived or limited by applicable laws, IBM is liable for no more than

1. damages for bodily injury (including death) and damage to real property and tangible personal property; and
2. the amount of any other actual direct damages, up to the charges (if recurring, 12 months' charges apply) for the Machine that is subject of the claim. For purposes of this item, the term "Machine" includes Machine Code and Licensed Internal Code.

This limit also applies to IBM's suppliers and your reseller. It is the maximum for which IBM, its suppliers, and your reseller are collectively responsible.

UNDER NO CIRCUMSTANCES IS IBM LIABLE FOR ANY OF THE FOLLOWING: 1) THIRD-PARTY CLAIMS AGAINST YOU FOR DAMAGES (OTHER THAN THOSE UNDER THE FIRST ITEM LISTED ABOVE); 2) LOSS OF, OR DAMAGE TO, YOUR RECORDS OR DATA; OR 3) SPECIAL, INCIDENTAL, OR INDIRECT DAMAGES OR FOR ANY ECONOMIC CONSEQUENTIAL DAMAGES, LOST PROFITS OR LOST SAVINGS, EVEN IF IBM, ITS SUPPLIERS OR YOUR RESELLER IS INFORMED OF THEIR POSSIBILITY. SOME JURISDICTIONS DO NOT ALLOW THE EXCLUSION OR LIMITATION OF INCIDENTAL OR CONSEQUENTIAL DAMAGES, SO THE ABOVE LIMITATION OR EXCLUSION MAY NOT APPLY TO YOU.

Governing Law

Governing Law: Both you and IBM consent to the application of the laws of the country in which you acquired the Machine to govern, interpret, and enforce all of your and IBM's rights, duties, and obligations arising from, or relating in any manner to, the subject matter of this Agreement, without regard to conflict of law principles.

Part 2 - Country-unique Terms

AMERICAS

BRAZIL

Governing Law: *The following is added after the first sentence:*

Any litigation arising from this Agreement will be settled exclusively by the court of Rio de Janeiro.

NORTH AMERICA

Warranty Service: *The following is added to this Section:*

To obtain warranty service from IBM in Canada or the United States, call 1-800-IBM-SERV (426-7378).

CANADA

Governing Law: *The following replaces "laws of the country in which you acquired the Machine" in the first sentence:*

laws in the Province of Ontario.

UNITED STATES

Governing Law: *The following replaces "laws of the country in which you acquired the Machine" in the first sentence:*

laws of the State of New York.

ASIA PACIFIC

AUSTRALIA

The IBM Warranty for Machines: *The following paragraph is added to this Section:*

The warranties specified in this Section are in addition to any rights you may have under the Trade Practices Act 1974 or other similar legislation and are only limited to the extent permitted by the applicable legislation.

Limitation of Liability: *The following is added to this Section:*

Where IBM is in breach of a condition or warranty implied by the Trade Practices Act 1974 or other similar legislation, IBM's liability is limited to the repair or replacement of the goods or the supply of equivalent goods. Where that condition or warranty relates to right to sell, quiet possession or clear title, or the goods are of a kind ordinarily acquired for personal, domestic or household use or consumption, then none of the limitations in this paragraph apply.

Governing Law: *The following replaces "laws of the country in which you acquired the Machine" in the first sentence:*

laws of the State or Territory.

CAMBODIA, LAOS, AND VIETNAM

Governing Law: *The following replaces "laws of the country in which you acquired the Machine" in the first sentence:*

laws of the State of New York.

The following is added to this Section:

Disputes and differences arising out of or in connection with this Agreement shall be finally settled by arbitration which shall be held in Singapore in accordance with the rules of the International Chamber of Commerce (ICC). The arbitrator or arbitrators designated in conformity with those rules shall have the power to rule on their own competence and on the validity of the Agreement to submit to arbitration. The arbitration award shall be final and binding for the parties without appeal and the arbitral award shall be in writing and set forth the findings of fact and the conclusions of law.

All proceedings shall be conducted, including all documents presented in such proceedings, in the English language. The number of arbitrators shall be three, with each side to the dispute being entitled to appoint one arbitrator.

The two arbitrators appointed by the parties shall appoint a third arbitrator before proceeding upon the reference. The third arbitrator shall act as chairman of the proceedings. Vacancies in the post of chairman shall be filled by the president of the ICC. Other vacancies shall be filled by the respective nominating party. Proceedings shall continue from the stage they were at when the vacancy occurred.

If one of the parties refuses or otherwise fails to appoint an arbitrator within 30 days of the date the other party appoints its, the first appointed arbitrator shall be the sole arbitrator, provided that the arbitrator was validly and properly appointed.

The English language version of this Agreement prevails over any other language version.

HONG KONG AND MACAU

Governing Law: *The following replaces “laws of the country in which you acquired the Machine” in the first sentence:*

laws of Hong Kong Special Administrative Region.

INDIA

Limitation of Liability: *The following replaces items 1 and 2 of this Section:*

1. liability for bodily injury (including death) or damage to real property and tangible personal property will be limited to that caused by IBM’s negligence;
2. as to any other actual damage arising in any situation involving nonperformance by IBM pursuant to, or in any way related to the subject of this Statement of Limited Warranty, IBM’s liability will be limited to the charge paid by you for the individual Machine that is the subject of the claim.

JAPAN

Governing Law: *The following sentence is added to this Section:*

Any doubts concerning this Agreement will be initially resolved between us in good faith and in accordance with the principle of mutual trust.

NEW ZEALAND

The IBM Warranty for Machines: *The following paragraph is added to this Section:*

The warranties specified in this Section are in addition to any rights you may have under the Consumer Guarantees Act 1993 or other legislation which cannot be excluded or limited. The Consumer Guarantees Act 1993 will not apply in respect of any goods which IBM provides, if you require the goods for the purposes of a business as defined in that Act.

Limitation of Liability: *The following is added to this Section:*

Where Machines are not acquired for the purposes of a business as defined in the Consumer Guarantees Act 1993, the limitations in this Section are subject to the limitations in that Act.

PEOPLE’S REPUBLIC OF CHINA (PRC)

Governing Law: *The following replaces this Section:*

Both you and IBM consent to the application of the laws of the State of New York (except when local law requires otherwise) to govern, interpret, and

enforce all your and IBM's rights, duties, and obligations arising from, or relating in any manner to, the subject matter of this Agreement, without regard to conflict of law principles.

Any disputes arising from or in connection with this Agreement will first be resolved by friendly negotiations, failing which either of us has the right to submit the dispute to the China International Economic and Trade Arbitration Commission in Beijing, the PRC, for arbitration in accordance with its arbitration rules in force at the time. The arbitration tribunal will consist of three arbitrators. The language to be used therein will be English and Chinese. An arbitral award will be final and binding on all the parties, and will be enforceable under the Convention on the Recognition and Enforcement of Foreign Arbitral Awards (1958).

The arbitration fee will be borne by the losing party unless otherwise determined by the arbitral award.

During the course of arbitration, this Agreement will continue to be performed except for the part which the parties are disputing and which is undergoing arbitration.

EUROPE, MIDDLE EAST, AFRICA (EMEA)

THE FOLLOWING TERMS APPLY TO ALL EMEA COUNTRIES:

The terms of this Statement of Limited Warranty apply to Machines purchased from IBM or an IBM reseller.

Warranty Service: If you purchase an IBM Machine in Austria, Belgium, Denmark, Estonia, Finland, France, Germany, Greece, Iceland, Ireland, Italy, Latvia, Lithuania, Luxembourg, Netherlands, Norway, Portugal, Spain, Sweden, Switzerland or United Kingdom, you may obtain warranty service for that Machine in any of those countries from either (1) an IBM reseller approved to perform warranty service or (2) from IBM. If you purchase an IBM Personal Computer Machine in Albania, Armenia, Belarus, Bosnia and Herzegovina, Bulgaria, Croatia, Czech Republic, Georgia, Hungary, Kazakhstan, Kirghizia, Federal Republic of Yugoslavia, Former Yugoslav Republic of Macedonia (FYROM), Moldova, Poland, Romania, Russia, Slovak Republic, Slovenia, or Ukraine, you may obtain warranty service for that Machine in any of those countries from either (1) an IBM reseller approved to perform warranty service or (2) from IBM.

If you purchase an IBM Machine in a Middle Eastern or African country, you may obtain warranty service for that Machine from the IBM entity within the country of purchase, if that IBM entity provides warranty service in that country, or from an IBM reseller, approved by IBM to perform warranty service on that Machine in that country. Warranty service in Africa is available within

50 kilometers of an IBM authorized service provider. You are responsible for transportation costs for Machines located outside 50 kilometers of an IBM authorized service provider.

Governing Law: The applicable laws that govern, interpret and enforce rights, duties, and obligations of each of us arising from, or relating in any manner to, the subject matter of this Statement, without regard to conflict of laws principles, as well as Country-unique terms and competent court for this Statement are those of the country in which the warranty service is being provided, except that in 1) Albania, Bosnia-Herzegovina, Bulgaria, Croatia, Hungary, Former Yugoslav Republic of Macedonia, Romania, Slovakia, Slovenia, Armenia, Azerbaijan, Belarus, Georgia, Kazakhstan, Kyrgyzstan, Moldova, Russia, Tajikistan, Turkmenistan, Ukraine, and Uzbekistan, the laws of Austria apply; 2) Estonia, Latvia, and Lithuania, the laws of Finland apply; 3) Algeria, Benin, Burkina Faso, Cameroon, Cape Verde, Central African Republic, Chad, Congo, Djibouti, Democratic Republic of Congo, Equatorial Guinea, France, Gabon, Gambia, Guinea, Guinea-Bissau, Ivory Coast, Lebanon, Mali, Mauritania, Morocco, Niger, Senegal, Togo, and Tunisia, this Agreement will be construed and the legal relations between the parties will be determined in accordance with the French laws and all disputes arising out of this Agreement or related to its violation or execution, including summary proceedings, will be settled exclusively by the Commercial Court of Paris; 4) Angola, Bahrain, Botswana, Burundi, Egypt, Eritrea, Ethiopia, Ghana, Jordan, Kenya, Kuwait, Liberia, Malawi, Malta, Mozambique, Nigeria, Oman, Pakistan, Qatar, Rwanda, Sao Tome, Saudi Arabia, Sierra Leone, Somalia, Tanzania, Uganda, United Arab Emirates, United Kingdom, West Bank/Gaza, Yemen, Zambia, and Zimbabwe, this Agreement will be governed by English Law and disputes relating to it will be submitted to the exclusive jurisdiction of the English courts; and 5) in Greece, Israel, Italy, Portugal, and Spain any legal claim arising out of this Statement will be brought before, and finally settled by, the competent court of Athens, Tel Aviv, Milan, Lisbon, and Madrid, respectively.

THE FOLLOWING TERMS APPLY TO THE COUNTRY SPECIFIED:

AUSTRIA AND GERMANY

The IBM Warranty for Machines: *The following replaces the first sentence of the first paragraph of this Section:*

The warranty for an IBM Machine covers the functionality of the Machine for its normal use and the Machine's conformity to its Specifications.

The following paragraphs are added to this Section:

The minimum warranty period for Machines is six months. In case IBM or your reseller is unable to repair an IBM Machine, you can alternatively ask for

a partial refund as far as justified by the reduced value of the unrepaired Machine or ask for a cancellation of the respective agreement for such Machine and get your money refunded.

Extent of Warranty: *The second paragraph does not apply.*

Warranty Service: *The following is added to this Section:*

During the warranty period, transportation for delivery of the failing Machine to IBM will be at IBM's expense.

Limitation of Liability: *The following paragraph is added to this Section:*

The limitations and exclusions specified in the Statement of Limited Warranty will not apply to damages caused by IBM with fraud or gross negligence and for express warranty.

The following sentence is added to the end of item 2:

IBM's liability under this item is limited to the violation of essential contractual terms in cases of ordinary negligence.

EGYPT

Limitation of Liability: *The following replaces item 2 in this Section:*

as to any other actual direct damages, IBM's liability will be limited to the total amount you paid for the Machine that is the subject of the claim. For purposes of this item, the term "Machine" includes Machine Code and Licensed Internal Code.

Applicability of suppliers and resellers (unchanged).

FRANCE

Limitation of Liability: *The following replaces the second sentence of the first paragraph of this Section:*

In such instances, regardless of the basis on which you are entitled to claim damages from IBM, IBM is liable for no more than: *(items 1 and 2 unchanged).*

IRELAND

Extent of Warranty: *The following is added to this Section:*

Except as expressly provided in these terms and conditions, all statutory conditions, including all warranties implied, but without prejudice to the generality of the foregoing all warranties implied by the Sale of Goods Act 1893 or the Sale of Goods and Supply of Services Act 1980 are hereby excluded.

Limitation of Liability: *The following replaces items one and two of the first paragraph of this Section:*

1. death or personal injury or physical damage to your real property solely caused by IBM's negligence; and
2. the amount of any other actual direct damages, up to 125 percent of the charges (if recurring, the 12 months' charges apply) for the Machine that is the subject of the claim or which otherwise gives rise to the claim.

Applicability of suppliers and resellers (unchanged).

The following paragraph is added at the end of this Section:

IBM's entire liability and your sole remedy, whether in contract or in tort, in respect of any default shall be limited to damages.

ITALY

Limitation of Liability: *The following replaces the second sentence in the first paragraph:*

In each such instance unless otherwise provided by mandatory law, IBM is liable for no more than:

1. *(unchanged)*
2. as to any other actual damage arising in all situations involving nonperformance by IBM pursuant to, or in any way related to the subject matter of this Statement of Warranty, IBM's liability, will be limited to the total amount you paid for the Machine that is the subject of the claim.

Applicability of suppliers and resellers (unchanged).

The following replaces the third paragraph of this Section:

Unless otherwise provided by mandatory law, IBM and your reseller are not liable for any of the following: *(items 1 and 2 unchanged)* 3) indirect damages, even if IBM or your reseller is informed of their possibility.

SOUTH AFRICA, NAMIBIA, BOTSWANA, LESOTHO AND SWAZILAND

Limitation of Liability: *The following is added to this Section:*

IBM's entire liability to you for actual damages arising in all situations involving nonperformance by IBM in respect of the subject matter of this Statement of Warranty will be limited to the charge paid by you for the individual Machine that is the subject of your claim from IBM.

UNITED KINGDOM

Limitation of Liability: *The following replaces items 1 and 2 of the first paragraph of this Section:*

1. death or personal injury or physical damage to your real property solely caused by IBM's negligence;

2. the amount of any other actual direct damages or loss, up to 125 percent of the charges (if recurring, the 12 months' charges apply) for the Machine that is the subject of the claim or which otherwise gives rise to the claim;

The following item is added to this paragraph:

3. breach of IBM's obligations implied by Section 12 of the Sale of Goods Act 1979 or Section 2 of the Supply of Goods and Services Act 1982.

Applicability of suppliers and resellers (unchanged).

The following is added to the end of this Section:

IBM's entire liability and your sole remedy, whether in contract or in tort, in respect of any default shall be limited to damages.

Apéndice B. Notices

IBM may not offer the products, services, or features discussed in this document in all countries. Consult your local IBM representative for information on the products and services currently available in your area. Any reference to an IBM product, program, or service is not intended to state or imply that only that IBM product, program, or service may be used. Any functionally equivalent product, program, or service that does not infringe any IBM intellectual property right may be used instead. However, it is the user's responsibility to evaluate and verify the operation of any non-IBM product, program, or service.

IBM may have patents or pending patent applications covering subject matter described in this document. The furnishing of this document does not give you any license to these patents. You can send license inquiries, in writing, to:

*IBM Director of Licensing
IBM Corporation
North Castle Drive
Armonk, NY 10504-1785
U.S.A.*

INTERNATIONAL BUSINESS MACHINES CORPORATION PROVIDES THIS PUBLICATION "AS IS" WITHOUT WARRANTY OF ANY KIND, EITHER EXPRESS OR IMPLIED, INCLUDING, BUT NOT LIMITED TO, THE IMPLIED WARRANTIES OF NON-INFRINGEMENT, MERCHANTABILITY OR FITNESS FOR A PARTICULAR PURPOSE. Some jurisdictions do not allow disclaimer of express or implied warranties in certain transactions, therefore, this statement may not apply to you.

This information could include technical inaccuracies or typographical errors. Changes are periodically made to the information herein; these changes will be incorporated in new editions of the publication. IBM may make improvements and/or changes in the product(s) and/or the program(s) described in this publication at any time without notice.

IBM may use or distribute any of the information you supply in any way it believes appropriate without incurring any obligation to you.

Any references in this publication to non-IBM Web sites are provided for convenience only and do not in any manner serve as an endorsement of those Web sites. The materials at those Web sites are not part of the materials for this IBM product, and use of those Web sites is at your own risk.

Any performance data contained herein was determined in a controlled environment. Therefore, the result obtained in other operating environments may vary significantly. Some measurements may have been made on development-level systems and there is no guarantee that these measurements will be the same on generally available systems. Furthermore, some measurements may have been estimated through extrapolation. Actual results may vary. Users of this document should verify the applicable data for their specific environment.

Trademarks

The following terms are trademarks of International Business Machines Corporation in the United States, other countries, or both:

HelpCenter
IBM
OS/2
ThinkPad
Ultrabay

Microsoft, Windows, and Windows NT are trademarks of Microsoft Corporation in the United States, other countries, or both.

Other company, product, or service names may be the trademarks or service marks of others.

Electronic emission notices

IBM ThinkPad CD-RW/DVD-ROM Combo III Ultrabay 2000 Drive

Federal Communications Commission (FCC) statement

Note: This equipment has been tested and found to comply with the limits for a Class B digital device, pursuant to Part 15 of the FCC Rules. These limits are designed to provide reasonable protection against harmful interference in a residential installation. This equipment generates, uses, and can radiate radio frequency energy and, if not installed and used in accordance with the instructions, may cause harmful interference to radio communications. However, there is no guarantee that interference will not occur in a particular installation. If this equipment does cause harmful interference to radio or television reception, which can be determined by turning the equipment off and on, the user is encouraged to try to correct the interference by one or more of the following measures:

- Reorient or relocate the receiving antenna.
- Increase the separation between the equipment and receiver.
- Connect the equipment into an outlet on a circuit different from that to which the receiver is connected.
- Consult an IBM authorized dealer or service representative for help.

Properly shielded and grounded cables and connectors must be used in order to meet FCC emission limits. Proper cables and connectors are available from IBM authorized dealers. IBM is not responsible for any radio or television interference caused by using other than recommended cables and connectors or by unauthorized changes or modifications to this equipment. Unauthorized changes or modifications could void the user's authority to operate the equipment.

This device complies with Part 15 of the FCC Rules. Operation is subject to the following two conditions: (1) this device may not cause harmful interference, and (2) this device must accept any interference received, including interference that may cause undesired operation.

Responsible party:

International Business Machines Corporation
New Orchard Road
Armonk, NY 10504
Telephone: 1-919-543-2193



Tested To Comply
With FCC Standards

FOR HOME OR OFFICE USE

Industry Canada Class B emission compliance statement

This Class B digital apparatus complies with Canadian ICES-003.

Avis de conformité a la réglementation d'Industrie Canada

Cet appareil numérique de la classe B est conforme à la norme NMB-003 du Canada.

Deutsche EMV-Direktive (electromagnetische Verträglichkeit)

Zulassungsbeseinigunglaut dem Deutschen Gesetz über die elektromagnetische Verträglichkeit von Geräten (EMVG) vom 30. August 1995 (bzw. der EMC EG Richtlinie 89/336):

Dieses Gerät ist berechtigt in Übereinstimmungmit dem Deutschen EMVG das EG-Konformitätszeichen - CE - zu führen. Verantwortlich für die Konformitätserklärung nach Paragraph 5 des EMVG ist die:

IBM Deutschland Informationssysteme GmbH, 70548 Stuttgart.

Informationen in Hinsicht EMVG Paragraph 3 Abs. (2) 2:

Das Gerät erfüllt die Schutzanforderungen nach EN 50082-1 und EN 55022 Klasse B.
--

EN 50082-1 Hinweis:

“Wird dieses Gerät in einer industriellen Umgebung betrieben (wie in EN 50082-2 festgelegt), dann kann es dabei eventuell gestört werden. In solch einem FA11 ist der Abstand bzw. die Abschirmung zu der industriellen Störquelle zu vergrößern.”

Anmerkung:

Um die Einhaltung des EMVG sicherzustellen sind die Geräte, wie in den IBM Handbüchern angegeben, zu installieren und zu betreiben.

European Union - emission directive

This product is in conformity with the protection requirements of EU Council Directive 89/336/ECC on the approximation of the laws of the Member States relating to electromagnetic compatibility.

IBM can not accept responsibility for any failure to satisfy the protection requirements resulting from a non-recommended modification of the product, including the fitting of non-IBM option cards.

This product has been tested and found to comply with the limits for Class B Information Technology Equipment according to European Standard EN 55022. The limits for Class B equipment were derived for typical residential environments to provide reasonable protection against interference with licensed communication devices.

Union Européenne - Directive Conformité électromagnétique

Ce produit est conforme aux exigences de protection de la Directive 89/336/EEC du Conseil de l'UE sur le rapprochement des lois des États membres en matière de compatibilité électromagnétique.

IBM ne peut accepter aucune responsabilité pour le manquement aux exigences de protection résultant d'une modification non recommandée du produit, y compris l'installation de cartes autres que les cartes IBM.

Ce produit a été testé et il satisfait les conditions de l'équipement informatique de Classe B en vertu de Standard européen EN 55022. Les conditions pour l'équipement de Classe B ont été définies en fonction d'un contexte résidentiel

ordinaire afin de fournir une protection raisonnable contre l'interférence d'appareils de communication autorisés.

Unione Europea - Directiva EMC (Conformidad electromagnética)

Este producto satisface los requisitos de protección del Consejo de la UE, Directiva 89/336/CEE en lo que a la legislación de los Estados Miembros sobre compatibilidad electromagnética se refiere.

IBM no puede aceptar responsabilidad alguna si este producto deja de satisfacer dichos requisitos de protección como resultado de una modificación no recomendada del producto, incluyendo el ajuste de tarjetas de opción que no sean IBM.

Este producto ha sido probado y satisface los límites para Equipos Informáticos Clase B de conformidad con el Estándar Europeo EN 55022. Los límites para los equipos de Clase B se han establecido para entornos residenciales típicos a fin de proporcionar una protección razonable contra las interferencias con dispositivos de comunicación licenciados.

Union Europea - Normativa EMC

Questo prodotto è conforme alle normative di protezione ai sensi della Direttiva del Consiglio dell'Unione Europea 89/336/CEE sull'armonizzazione legislativa degli stati membri in materia di compatibilità elettromagnetica.

IBM non accetta responsabilità alcuna per la mancata conformità alle normative di protezione dovuta a modifiche non consigliate al prodotto, compresa l'installazione di schede e componenti di marca diversa da IBM.

Le prove effettuate sul presente prodotto hanno accertato che esso rientra nei limiti stabiliti per le apparecchiature di informatica Classe B ai sensi della Norma Europea EN 55022. I limiti delle apparecchiature della Classe B sono stati stabiliti al fine di fornire ragionevole protezione da interferenze mediante dispositivi di comunicazione in concessione in ambienti residenziali tipici.

이 기기는 가정용으로 전자파 적합등록을 한 기기로서
주거지역에서는 물론 모든 지역에서 사용할 수 있습니다.

この装置は、情報処理装置等電波障害自主規制協議会（VCCI）の基準に基づきクラスB情報技術装置です。この装置は、家庭環境で使用することを目的としていますが、この装置がラジオやテレビジョン受信機に近接して使用されると、受信障害を引き起こすことがあります。
取扱説明書に従って正しい取り扱いをして下さい。

Japanese statement of compliance for products less than or equal to 20 A per phase

高調波ガイドライン適合品

IBM