



@server

xSeries 260, xSeries 366, xSeries 460, and xSeries MXE 460
FAQ

Hints and Tips





@server

xSeries 260, xSeries 366, xSeries 460, and xSeries MXE 460
FAQ

Hints and Tips

Note: Before using this information and the product it supports, be sure to read the general information in Appendix B, “Notices,” on page 27.

Second Edition (October 2005)

© Copyright International Business Machines Corporation 2004. All rights reserved.

US Government Users Restricted Rights – Use, duplication or disclosure restricted by GSA ADP Schedule Contract with IBM Corp.

Contents

Chapter 1. Introduction	1
Related documentation	1
Before you begin	2
Major components of the xSeries 260 Type 8865 server	3
Features and specifications.	4
Major components of the xSeries 366 Type 8863, xSeries 460 Type 8872, and xSeries MXE 460 Type 8874 server.	5
Features and specifications.	6
Features and specifications.	7
Chapter 2. Hints and tips	9
Component removal and installation	9
Microprocessor tray	9
(xSeries 460 and xSeries MXE 460 server only) Power supplies.	10
(xSeries 460 and xSeries MXE 460 server only) SAS hard disk drive backplane installation.	11
Memory and microprocessors	12
Bent pins on memory card and possible F2 checkpoint POST failure	12
Memory module installation	12
Memory performance	12
Microprocessor performance	13
Operator information panel and lightpath diagnostics	13
Dim operator information panel LEDs	13
Information LED is lit if integrated Ethernet controller is disabled	13
Light path diagnostics	14
(xSeries 460 and xSeries MXE 460 server only) Power-control-button shield	16
Optional devices	16
ServeRAID-8i controller.	16
Supported options.	18
USB diskette drive	18
Problem determination	18
(Trained service technicians only) Checkpoint codes	18
DVD-ROM drive access	18
Force power on jumper	18
POST error code 001801nn	19
Server fails to start	19
Remote Supervisor Adapter II SlimLine and BMC	20
BMC log entries	20
Boot order communication.	20
Cannot update Remote Supervisor Adapter II SlimLine IP address in BIOS	20
Communication failure and long POST	20
Error indicates microprocessor board bent pins	21
Firmware updates	21
Remote Supervisor Adapter II SlimLine and BMC troubleshooting tips.	21
Remote Supervisor Adapter II SlimLine might fail on ac power cycle	21
Remote Supervisor Adapter II SlimLine network access delay.	21
Software	22
Broadcom Gigabyte Ethernet controller default settings	22
Firmware updates	22
IBM Director	22
PCI scan sequence	22
SAS Windows 2000 Server device driver	22
Support telephone numbers	22

Chapter 3. Getting help and technical assistance	23
Before you call	23
Using the documentation	23
Getting help and information from the World Wide Web	24
Software service and support	24
Hardware service and support	24
Appendix A. xSeries 260 model PAE	25
Bezel and hard disk drive cage replacement	25
Hard disk drives	25
Support	25
Closing the tray handle during installation	25
Tray alignment	25
Removal	25
SAS hard disk drives auto-negotiate 1.5 GB/ps transfer speed	26
Appendix B. Notices	27
Edition notice	27
Trademarks	28
Important notes.	28

Chapter 1. Introduction

The information provided in this document is based on technical observations, and it is intended to supplement the IBM® @server™ xSeries® 260, xSeries 366, xSeries 460, and xSeries MXE 460 documentation that comes with the server. The topics are arranged alphabetically to help you find the information.

See Appendix A, “xSeries 260 model PAE,” on page 25 for installation and troubleshooting hints and tips specific to the xSeries 260 model PAE server.

The latest versions of the documentation for the server is available in Portable Document Format (PDF) from <http://www.ibm.com/support/>.

Related documentation

The server documentation includes the following documents:

- *Problem Determination and Service Guide*

This document is in Portable Document Format (PDF) on the IBM *xSeries Documentation* CD. It contains information to help you solve problems yourself, and it contains information for service technicians.

- *Installation Guide*

This printed document contains instructions for setting up the server and basic instructions for installing some options.

- *User's Guide*

This document is in PDF on the IBM *xSeries Documentation* CD. It provides general information about the server, including information about features, and how to configure the server. It also contains detailed instructions for installing, removing, and connecting optional devices that the server supports.

- *Rack Installation Instructions*

(Some models only) This printed document contains instructions for installing the server in a rack.

- *Safety Information*

This document is in PDF on the IBM *xSeries Documentation* CD. It contains translated caution and danger statements. Each caution and danger statement that appears in the documentation has a number that you can use to locate the corresponding statement in your language in the *Safety Information* document.

- *Warranty and Support Information*

This document is in PDF on the IBM *xSeries Documentation* CD. It contains information about the terms of the warranty and about service and assistance.

The server might have features that are not described in the documentation that you received with the server. The documentation might be updated occasionally to include information about those features, or technical updates might be available to provide additional information that is not included in the server documentation. These updates are available from the IBM Web site. To check for updated documentation and technical updates, complete the following steps.

Note: Changes are made periodically to the IBM Web site. The actual procedure might vary slightly from what is described in this document.

1. Go to <http://www.ibm.com/support/>.

2. Under **Search technical support**, type 8863, 8865, 8872, or 8874 and click **Search**.

You can obtain up-to-date information about the server and other IBM server products at <http://www.ibm.com/eserver/xseries/>.

Before you begin

Read the following information before you use the hints and tips in this document:

- Review the “Safety information” and “Handling static-sensitive devices” sections in the documentation that comes with the server. These guidelines will help you work safely while working with the server or options.
- Back up all important data before you make changes to disk drives.
- For a list of supported options for the server, go to <http://www.ibm.com/servers/eserver/serverproven/compat/us/>.
- Verify the following server components and connections:
 - All adapters, boards, fans, power supplies, and internal devices are fully seated and connected correctly.
 - All cables and cords are connected securely to the server and to any installed optional devices.
 - Each drive bay contains either a drive or a filler panel.
 - Each unoccupied PCI-X slot contains an expansion-slot cover.
 - (xSeries 460 and xSeries MXE 460 server only) If the server has redundant power, power supplies are installed in both power-supply bays.
 - (xSeries 460 and xSeries MXE 460 server only) For redundant and hot-swappable operation, the power supplies are connected to 200-240 V ac. The power supplies are hot-swappable and redundant only at 200-240 V ac.
 - All microprocessors are the same type and have the same cache size and clock speed.
- Verify the server installation:
 - There is sufficient space around the server to allow the cooling system to work properly.
 - The top cover is closed during normal operation. For proper cooling, do not leave the cover open for more than 15 minutes.
 - The rack into which you plan to install the server has perforated doors.
- When you replace a hot-swap drive, wait 15 seconds after removing the defective drive before you install the new drive.

Major components of the xSeries 260 Type 8865 server

The following illustration shows the major components in the server.

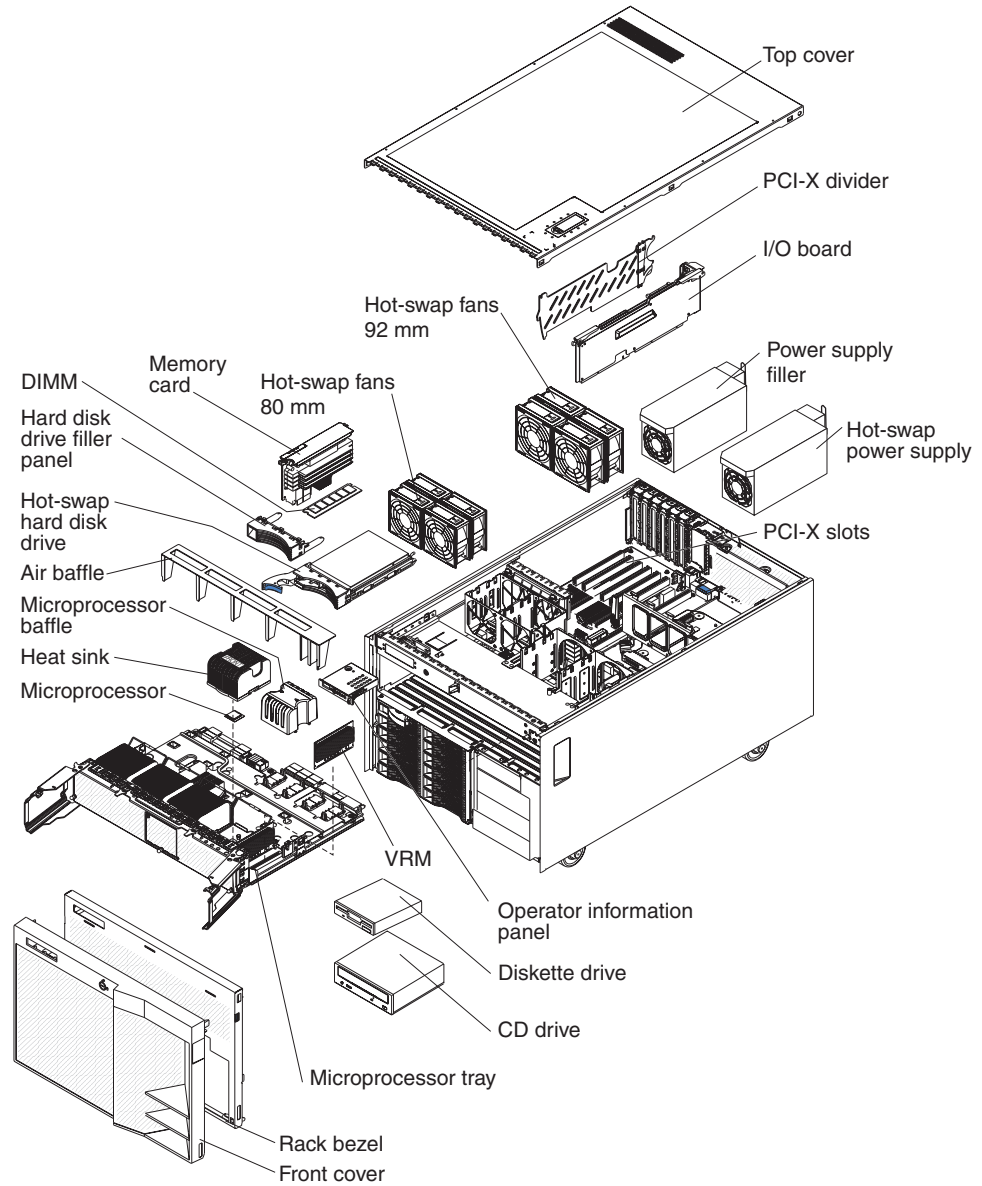

Features and specifications

The following information is a summary of the features and specifications of the server. Depending on the server model, some features might not be available, or some specifications might not apply.

Table 1. xSeries 260 Type 8865 server features and specifications

<p>Microprocessor:</p> <ul style="list-style-type: none"> Intel® Xeon™ 1 MB Level-2 cache 667 MHz front-side bus (FSB) Support for up to four microprocessors <p>Note: Use the Configuration/Setup Utility program to determine the type and speed of the microprocessors.</p> <p>Memory:</p> <ul style="list-style-type: none"> Minimum: 1 GB depending on server model, expandable to 64 GB Type: 333 MHz, registered, ECC, PC2-3200 double data rate (DDR) II, SDRAM Sizes: 512 MB (some models only), 1 GB, 2 GB, or 4 GB in pairs Connectors: Two-way interleaved, four dual inline memory module (DIMM) connectors per memory card Maximum: Four memory cards, each card containing two pairs of PC2-3200 DDRII DIMMs <p>Drives:</p> <ul style="list-style-type: none"> CD: IDE Diskette: 1.44 MB Serial Attached SCSI (SAS) hard disk drive <p>Expansion bays:</p> <ul style="list-style-type: none"> Twelve SAS, 3.5-inch bays Three 5.25-inch bays (CD-ROM installed) One 3.5-inch bay (diskette drive installed) <p>Expansion slots:</p> <p>Six PCI-X 2.0 hot-plug 266 MHz/64-bit slots</p> <p>Upgradeable microcode:</p> <p>System BIOS, diagnostics, service processor, BMC, and SAS microcode</p> <p>Power supply:</p> <ul style="list-style-type: none"> Standard: Two 775 watt 110 V or 220 V ac input dual-rated power supplies Upgradeable to four power supplies 	<p>Size:</p> <ul style="list-style-type: none"> 7 U Height: 311 mm (12.3 in.) Depth: 715 mm (28.15 in.) Width: 440 mm (17.32 in.) Weight: approximately 55 kg (121.2 lb) when fully configured or 47 kg (104 lb) minimum <p>Racks are marked in vertical increments of 4.45 cm (1.75 inches). Each increment is referred to as a unit, or "U." A 1-U-high device is 4.45 cm (1.75 inches) tall.</p> <p>Integrated functions:</p> <ul style="list-style-type: none"> Baseboard management controller IBM EXA-32 Chipset with integrated memory and I/O controller Service processor support for Remote Supervisor Adapter II SlimLine Light path diagnostics Three Universal Serial Bus (USB) ports (2.0) <ul style="list-style-type: none"> Two on rear of server One on front of server Broadcom 5704C dual 10/100/1000 Gigabit Ethernet controllers ATI 7000-M video <ul style="list-style-type: none"> 16 MB video memory SVGA compatible Mouse connector Keyboard connector Serial connector <p>Acoustical noise emissions:</p> <ul style="list-style-type: none"> Sound power, idle: 6.6 bel declared Sound power, operating: 6.6 bel declared <p>Environment:</p> <ul style="list-style-type: none"> Air temperature: <ul style="list-style-type: none"> Server on: 10° to 35°C (50.0° to 95.0°F); altitude: 0 to 2133 m (6998.0 ft) Server off: 10° to 43°C (50.0° to 109.4°F); maximum altitude: 2133 m (6998.0 ft) Humidity: <ul style="list-style-type: none"> Server on: 8% to 80% Server off: 8% to 80% 	<p>Heat output:</p> <p>Approximate heat output in British thermal units (Btu) per hour:</p> <ul style="list-style-type: none"> Minimum configuration: 2006 Btu (588 watts) per hour Maximum configuration: 6346 Btu (1860 watts) per hour <p>Electrical input:</p> <ul style="list-style-type: none"> Sine-wave input (50-60 Hz) required Input voltage low range: <ul style="list-style-type: none"> Minimum: 100 V ac Maximum: 127 V ac Input voltage high range: <ul style="list-style-type: none"> Minimum: 200 V ac Maximum: 240 V ac Approximate input kilovolt-amperes (kVA): <ul style="list-style-type: none"> Minimum: 0.60 kVA Maximum: 1.9 kVA <p>Notes:</p> <ol style="list-style-type: none"> Power consumption and heat output vary depending on the number and type of optional features installed and the power-management optional features in use. These levels were measured in controlled acoustical environments according to the procedures specified by the American National Standards Institute (ANSI) S12.10 and ISO 7779 and are reported in accordance with ISO 9296. Actual sound-pressure levels in a given location might exceed the average values stated because of room reflections and other nearby noise sources. The declared sound-power levels indicate an upper limit, below which a large number of computers will operate.
---	--	---

Major components of the xSeries 366 Type 8863, xSeries 460 Type 8872, and xSeries MXE 460 Type 8874 server

The following illustration shows the major components in the server.

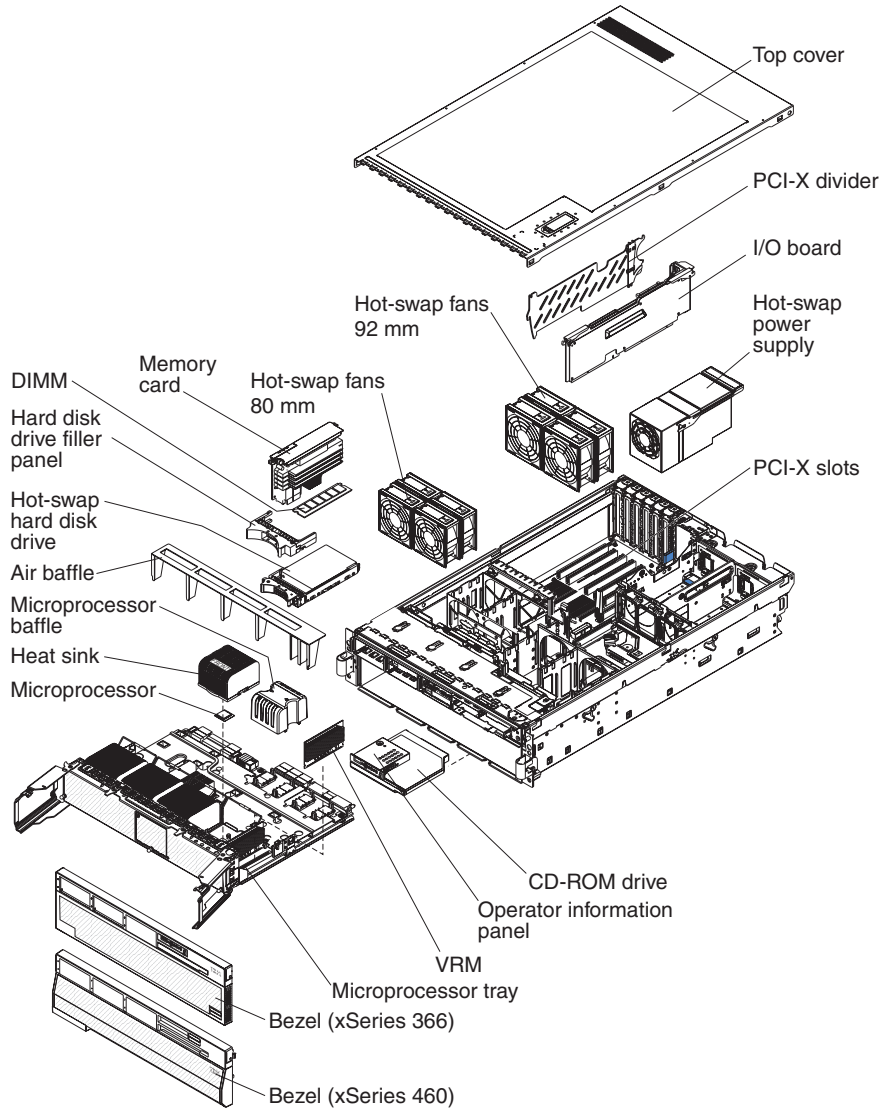

Features and specifications

The following information is a summary of the features and specifications of the xSeries 366 server. Depending on the server model, some features might not be available, or some specifications might not apply.

Table 2. xSeries 366 Type 8863 server features and specifications

<p>Microprocessor:</p> <ul style="list-style-type: none"> • Intel Xeon • 1 MB (minimum) Level-2 cache • 667 MHz front-side bus (FSB) • Support for up to four microprocessors <p>Note: Use the Configuration/Setup Utility program to determine the type and speed of the microprocessors.</p> <p>Memory:</p> <ul style="list-style-type: none"> • Minimum: 2 GB depending on server model, expandable to 32 GB • Type: 333 MHz, registered, ECC, PC2-3200 double data rate (DDR) II, SDRAM • Sizes: 1 GB or 2 GB in pairs • Connectors: Two-way interleaved, four dual inline memory module (DIMM) connectors per memory card • Maximum: Four memory cards, each card containing two pairs of PC2-3200 DDRII DIMMS <p>Drives:</p> <ul style="list-style-type: none"> • Slim DVD-ROM: IDE • Serial Attached SCSI (SAS) hard disk drives <p>Expansion bays:</p> <ul style="list-style-type: none"> • Six SAS, 2.5-inch bays • One 12.7-mm removable-media drive bay (DVD-ROM drive installed) <p>Expansion slots:</p> <p>Six PCI-X 2.0 hot-plug 266 MHz/64-bit slots</p> <p>Upgradeable microcode:</p> <p>System BIOS, diagnostics, service processor, BMC, and SAS microcode</p> <p>Power supply:</p> <ul style="list-style-type: none"> • Standard: One dual-rated power supply <ul style="list-style-type: none"> – 1300 watts at 220 V ac input – 650 watts at 110 V ac input • Upgradeable to two power supplies (hot-swappable at 220 V ac only) 	<p>Size:</p> <ul style="list-style-type: none"> • 3U • Height: 128.35 mm (5.05 in.) • Depth: 715 mm (28.15 in.) • Width: 440 mm (17.32 in.) • Weight: approximately 38.5 kg (85 lb) when fully configured or 31.75 kg (70 lb) minimum <p>Racks are marked in vertical increments of 4.45 cm (1.75 inches). Each increment is referred to as a unit, or “U.” A 1-U-high device is 4.45 cm (1.75 inches) tall.</p> <p>Integrated functions:</p> <ul style="list-style-type: none"> • Baseboard management controller • IBM EXA-32 Chipset with integrated memory and I/O controller • Service processor support for Remote Supervisor Adapter II SlimLine • Light path diagnostics • Three Universal Serial Bus (USB) ports <ul style="list-style-type: none"> – Two on rear of server – One on front of server • Broadcom 5704C dual 10/100/1000 Gigabit Ethernet controllers • ATI 7000-M video <ul style="list-style-type: none"> – 16 MB video memory – SVGA compatible • Mouse connector • Keyboard connector • Serial connector <p>Acoustical noise emissions:</p> <ul style="list-style-type: none"> • Sound power, idle: 6.6 bel declared • Sound power, operating: 6.6 bel declared <p>Environment:</p> <ul style="list-style-type: none"> • Air temperature: <ul style="list-style-type: none"> – Server on: 10° to 35°C (50.0° to 95.0°F); altitude: 0 to 2133 m (6998.0 ft) – Server off: 10° to 43°C (50.0° to 109.4°F); maximum altitude: 2133 m (6998.0 ft) • Humidity: <ul style="list-style-type: none"> – Server on: 8% to 80% – Server off: 8% to 80% 	<p>Heat output:</p> <p>Approximate heat output in British thermal units (Btu) per hour:</p> <ul style="list-style-type: none"> • Minimum configuration: 1364 Btu (400 watts) per hour • Maximum configuration: 5780 Btu (1700 watts) per hour <p>Electrical input:</p> <ul style="list-style-type: none"> • Sine-wave input (50-60 Hz) required • Input voltage low range: <ul style="list-style-type: none"> – Minimum: 100 V ac – Maximum: 127 V ac • Input voltage high range: <ul style="list-style-type: none"> – Minimum: 200 V ac – Maximum: 240 V ac • Approximate input kilovolt-amperes (kVA): <ul style="list-style-type: none"> – Minimum: 0.40 kVA – Maximum: 1.6 kVA <p>Notes:</p> <ol style="list-style-type: none"> 1. Power consumption and heat output vary depending on the number and type of optional features installed and the power-management optional features in use. 2. These levels were measured in controlled acoustical environments according to the procedures specified by the American National Standards Institute (ANSI) S12.10 and ISO 7779 and are reported in accordance with ISO 9296. Actual sound-pressure levels in a given location might exceed the average values stated because of room reflections and other nearby noise sources. The declared sound-power levels indicate an upper limit, below which a large number of computers will operate.
---	---	---

Features and specifications

The following information is a summary of the features and specifications of the xSeries 460 servers.

Table 3. xSeries 460 Type 8872 and xSeries MXE 460 Type 8874 server features and specifications

<p>Microprocessor (not standard on MXE 460 models):</p> <ul style="list-style-type: none"> • Intel Xeon MP • 1 MB (minimum) Level-2 cache • 4 MB or 8 MB Level-3 cache • 667 MHz front-side bus (FSB) • Support for up to four microprocessors <p>Note: Use the Configuration/Setup Utility program to determine the type and speed of the microprocessors.</p> <p>Memory (not standard on MXE 460 models):</p> <ul style="list-style-type: none"> • Minimum: 2 GB depending on server model, expandable to 64 GB • Type: 333 MHz, registered, ECC, PC2-3200 double data rate (DDR) II, SDRAM • Sizes: 1 GB, 2 GB, or 4 GB in pairs • Connectors: Two-way interleaved, four dual inline memory module (DIMM) connectors per memory card • Maximum: Four memory cards, each card containing two pairs of PC2-3200 DDRII DIMMs <p>Drives:</p> <ul style="list-style-type: none"> • Slim DVD-ROM: IDE • Serial Attached SCSI (SAS) hard disk drives <p>Expansion bays:</p> <ul style="list-style-type: none"> • Six SAS, 2.5-inch bays • One 12.7-mm removable-media drive bay (DVD drive installed, standard on some models only) <p>Expansion slots:</p> <p>Six PCI-X 2.0 hot-plug 266 MHz/64-bit slots</p> <p>Upgradeable microcode:</p> <p>System BIOS, diagnostics, service processor, BMC, and SAS microcode</p> <p>Power supply:</p> <ul style="list-style-type: none"> • Standard: Two dual-rated power supplies <ul style="list-style-type: none"> – 1300 watts at 220 V ac input – 650 watts at 110 V ac input • Hot-swappable at 220 V ac only 	<p>Size:</p> <ul style="list-style-type: none"> • 3U • Height: 128.35 mm (5.05 in.) • Depth: 715 mm (28.15 in.) • Width: 440 mm (17.32 in.) • Weight: approximately 38.5 kg (85 lb) when fully configured or 31.75 kg (70 lb) minimum <p>Racks are marked in vertical increments of 4.45 cm (1.75 inches). Each increment is referred to as a unit, or “U.” A 1-U-high device is 4.45 cm (1.75 inches) tall.</p> <p>Integrated functions:</p> <ul style="list-style-type: none"> • Baseboard management controller • IBM EXA-32 Chipset with integrated memory and I/O controller • Service processor support for Remote Supervisor Adapter II SlimLine • Light path diagnostics • Three Universal Serial Bus (USB) ports (2.0) <ul style="list-style-type: none"> – Two on rear of server – One on front of server • Broadcom 5704C dual 10/100/1000 Gigabit Ethernet controllers • ATI 7000-M video <ul style="list-style-type: none"> – 16 MB video memory – SVGA compatible • Mouse connector • Keyboard connector • Serial connector • SMP Expansion Ports <p>Acoustical noise emissions:</p> <ul style="list-style-type: none"> • Sound power, idle: 6.6 bel declared • Sound power, operating: 6.6 bel declared <p>Environment:</p> <ul style="list-style-type: none"> • Air temperature: <ul style="list-style-type: none"> – Server on: 10° to 35°C (50.0° to 95.0°F); altitude: 0 to 2133 m (6998.0 ft) – Server off: 10° to 43°C (50.0° to 109.4°F); maximum altitude: 2133 m (6998.0 ft) • Humidity: <ul style="list-style-type: none"> – Server on: 8% to 80% – Server off: 8% to 80% 	<p>Heat output:</p> <p>Approximate heat output in British thermal units (Btu) per hour:</p> <ul style="list-style-type: none"> • Minimum configuration: 1364 Btu (400 watts) per hour • Maximum configuration: 5780 Btu (1700 watts) per hour <p>Electrical input:</p> <ul style="list-style-type: none"> • Sine-wave input (50-60 Hz) required • Input voltage low range: <ul style="list-style-type: none"> – Minimum: 100 V ac – Maximum: 127 V ac • Input voltage high range: <ul style="list-style-type: none"> – Minimum: 200 V ac – Maximum: 240 V ac • Approximate input kilovolt-amperes (kVA): <ul style="list-style-type: none"> – Minimum: 0.40 kVA – Maximum: 1.6 kVA <p>Notes:</p> <ol style="list-style-type: none"> 1. Power consumption and heat output vary depending on the number and type of optional features installed and the power-management optional features in use. 2. These levels were measured in controlled acoustical environments according to the procedures specified by the American National Standards Institute (ANSI) S12.10 and ISO 7779 and are reported in accordance with ISO 9296. Actual sound-pressure levels in a given location might exceed the average values stated because of room reflections and other nearby noise sources. The declared sound-power levels indicate an upper limit, below which a large number of computers will operate. <p>Scalability support:</p> <p>Maximum configuration:</p> <ul style="list-style-type: none"> • Eight nodes • 32-way operation • 128 DIMMs • 48 SAS hard disk drives • 48 PCI-X adapters
---	--	---

Chapter 2. Hints and tips

This chapter contains installation and troubleshooting hints and tips related to the xSeries 260, xSeries 366, xSeries 460, and xSeries MXE 460 servers. This information is intended to supplement the server documentation (listed on page 1).

Component removal and installation

This section contains information about component removal and installation.

Microprocessor tray

The following notes describe information that you must consider concerning opening and closing the microprocessor tray.

Attention: To avoid damage to the microprocessor board, microprocessor heat sinks, memory cards, DIMMs, and other server components, when you open the microprocessor tray, observe the following guidelines:

- Remove all fans and memory cards before you open the microprocessor tray.
- If the microprocessor tray does not slide freely, lift up on the top of the hard disk drive bays while opening the microprocessor tray to avoid damage to the microprocessor heat sinks. See <http://www.ibm.com/support/> and search for MIGR-60199 for additional information on opening the microprocessor tray.
- Make sure that the air baffle lies flat and within the grooves on top of the microprocessor heat sinks and microprocessor baffles and that the air baffle remains in place while you close the microprocessor tray. You might find it helpful to hold the air baffle in place with your thumbs while closing the microprocessor tray.

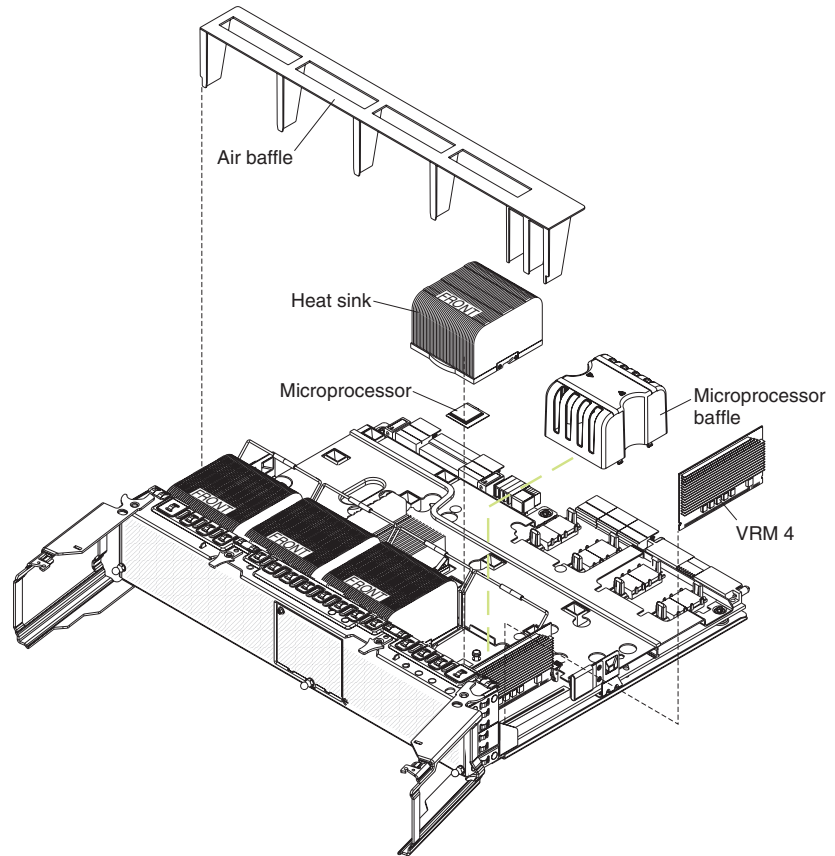

- (xSeries 260 server only) When removing the microprocessor tray from the server, you might experience difficulty pressing the microprocessor-tray retention latches. Press on the top edge of the retention latches. If the problem remains, use a screwdriver to press the retention latches.

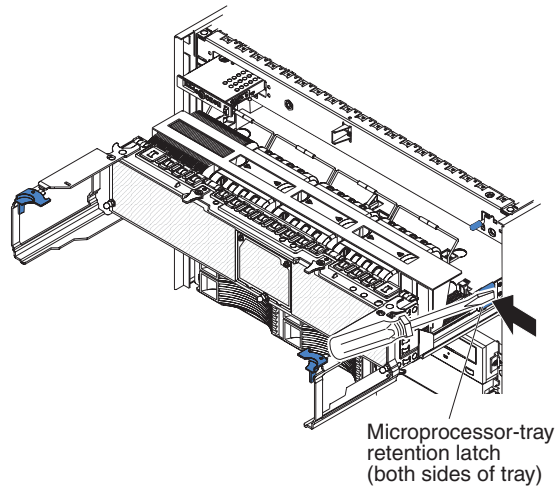

(xSeries 460 and xSeries MXE 460 server only) Power supplies

Each power supply is rated at 1300 watts at 220 V ac, and is capable of powering a fully loaded server without redundancy. At 110 V ac, the power rating is 650 watts for each power supply.

The following notes describe information that you must consider when installing a hot swap power supply:

- The server comes with a minimum of one power supply and supports up to two power supplies (hot-swappable at 220 V ac only).
- The power supplies are numbered from left to right (1 and 2) as viewed from the rear of the server. Power supplies must be installed in the following sequence: power supply 1, then power supply 2.
- One 110 V ac power supply can support a maximum configuration of 1 microprocessor, 2 PCI-X adapters, 3 hard disk drives, and 4 DIMMs. If you exceed this configuration, you must either install a second power supply or use 220 V ac input.

Two power supplies at 110 V ac will not support a full configuration with redundancy. Use 220 V ac input to maintain full redundancy with a full configuration.

- The NONRED LED on the light path diagnostics panel is lit to indicate that the server is operating with non-redundant power. Either add an optional power supply or use a 220 V ac input source.
- Check the BMC log for errors before replacing a suspected bad power supply. For example, a shorted circuit board might indicate improper voltage levels in the BMC log due to current-limiting circuit protection.

(xSeries 460 and xSeries MXE 460 server only) SAS hard disk drive backplane installation

When the SAS hard disk drive backplane is reinstalled, connectors on both the hard disk drives and backplane can become damaged if the backplane is not seated properly. Make sure that the backplane is fully seated before installing the hard disk drives. Three tabs on the rear of the backplane assembly must be fully seated into slots in the chassis.

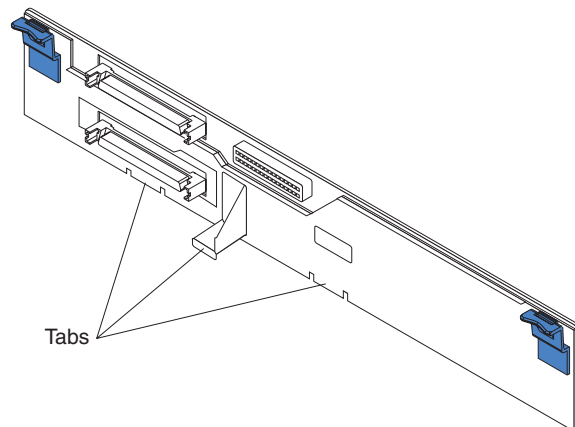

Memory and microprocessors

This section contains information about memory and microprocessors.

Bent pins on memory card and possible F2 checkpoint POST failure

If POST fails at checkpoint F2, check all memory cards for possible bent pins. If the pins are bent, replace the damaged memory card. Checkpoint codes are shown on the checkpoint display, which is on the I/O board.

Memory module installation

To avoid damage, you must handle memory modules (DIMMs) gently during installation.

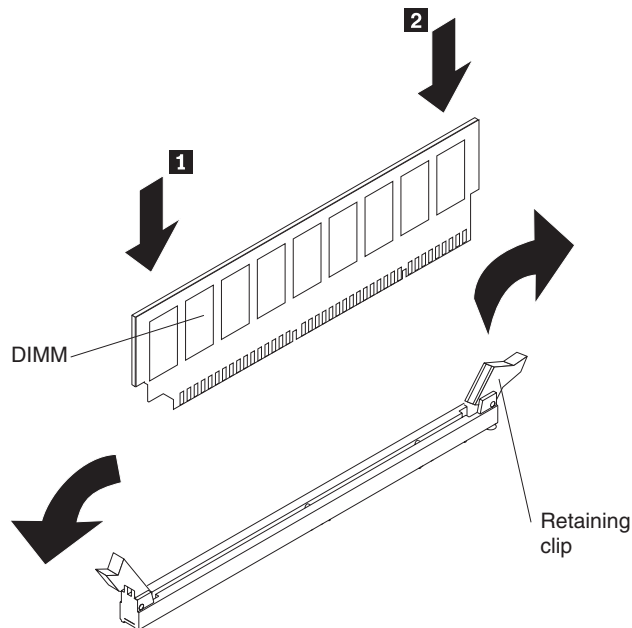

See the information that comes with your server and the following instructions to install memory modules:

1. Turn the DIMM so that the DIMM keys align correctly with the slot.
2. Insert the DIMM into the connector by aligning the edges of the DIMM with the slots at the ends of the DIMM connector. Firmly press one end of the DIMM into the connector; then, press the other end into the connector. The retaining clips snap into the locked position when the DIMM is seated in the connector. If there is a gap between the DIMM and the retaining clips, the DIMM has not been correctly inserted; open the retaining clips, remove the DIMM, and then reinsert it.

Memory performance

The following notes describe information that you must consider about memory performance:

- The number of installed DIMMs is critical to memory performance. The optimal configuration is 16 installed DIMMs. Eight installed DIMMs provide 3-5% slower performance. Compared to eight DIMMs, four installed DIMMs provide 5-10% slower performance, for some applications.

- You can populate more than one memory card with DIMMs to improve memory performance. With four DIMMs installed in a single memory card the server is slower than with two DIMMS each installed in two memory cards. Each memory card supports four DIMMs.
- Full array memory mirroring (FAMM) creates a redundant copy of system memory. This provides increased fault tolerance, but also reduces the available memory by half. Memory performance is not affected, while system performance typically follows maximum available memory.

Microprocessor performance

The server is configured by default to optimize database transaction processing. However, if the server runs file server or web server applications, database transaction processing slows performance. Disabling prefetch processing for applications that don't take advantage of it can improve performance 10-20%. Prefetch processing forces the microprocessors to preload extra cache lines for every request.

Complete the following steps to disable prefetch processing:

1. Turn on the server.
2. When the prompt Press F1 for Configuration/Setup appears, press F1.
3. Select **Advanced Setup**.
4. Select **CPU Options**.
5. Select **HW Prefetch**.
6. **Disable** the feature from this window.

Operator information panel and lightpath diagnostics

This section contains information about the operator information panel and lightpath diagnostics.

Dim operator information panel LEDs

Problem: The operator information panel LEDs might appear dim. This can occur because the plastic contact separators on the I/O board connector (where the flex cable plugs) are sharp and can scrape the metal contacts on either end of the cable when the flex cable is inserted.

Solution: Complete the following steps, if the operator information panel LEDs appear dim:

1. Turn off the server.
2. Remove the white flex operator information panel ribbon cable from the I/O board and inspect the metal contacts for damage.
3. Replace the cable if the metal contacts are lifted from the cable or if there are signs of the metal being scraped.
4. See <http://www.ibm.com/support/> and search for MIGR-60141 for further information.

Note: This problem might also result from a blown fuse on the I/O board. If that condition occurs, replace the I/O board.

Information LED is lit if integrated Ethernet controller is disabled

Description: If the integrated Ethernet controller is disabled from the Configuration/Setup Utility program, the information LED on the operator information

panel and the LOG LED on the light path diagnostics panel might light during POST. The Planar/PCI Device is disabled or not responding error message might also display in the POST error log.

Solution: Either enable the Ethernet controller or clear the POST error log to turn off the LEDs.

Light path diagnostics

To view the light path diagnostics panel, press the release latch on the front of the operator information panel to the left; then, slide it forward. This reveals the light path diagnostics panel. Lit LEDs on this panel indicate the type of error that has occurred.

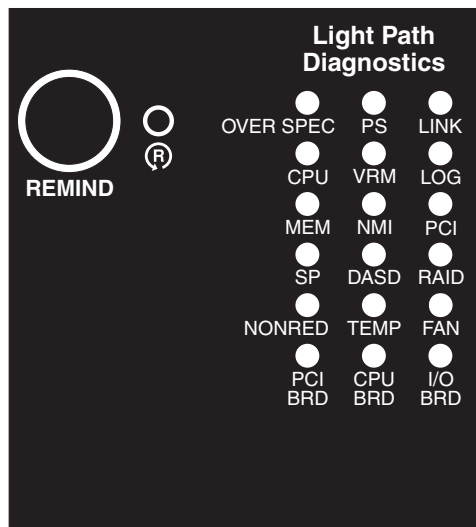

Information LED

The following illustration shows the operator information panel.

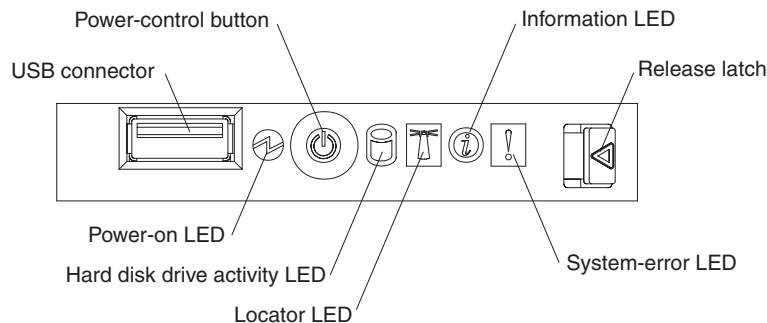

When the information LED on the operator information panel is lit, it indicates that there is a suboptimal condition in the server and that light path diagnostics will light an additional LED to help isolate the condition. If the LOG LED on the light path diagnostics panel is lit, information about the condition is available in the baseboard management controller (BMC) log or in the system-event log. The condition might be that the BMC log is full or almost full.

This LED and the LEDs on the light path diagnostics panel remain lit until you resolve the condition. If the only condition is that the BMC log is full or almost full, clear the BMC log or the system-event log through the Configuration/Setup Utility program to turn off the lit LEDs.

Important: If the server has a baseboard management controller, clear the BMC log and system-event log after you resolve all conditions. This will turn off the information LED and LOG LED, if all conditions are resolved.

Complete the following steps to clear the BMC log:

1. Turn on the server.
2. When the prompt Press F1 for Configuration/Setup appears, press F1.
3. Select **Advanced Setup**.
4. Select **Baseboard management controller (BMC) settings**.
5. Select **BMC System Event Log**.
6. Select **Clear error logs** to clear the BMC log.

You can also clear the BMC log using the SMBridge command-line tools. See <http://www.ibm.com/support/> and search for MIGR-57729 for additional information on the SMBridge utility.

PCI-X board LEDs

Use the PCI LED on the light path diagnostics panel to diagnose an adapter problem. If the PCI LED is lit, a PCI adapter has failed. To identify the failing adapter, remove the top cover and view the attention LEDs on the PCI-X board to isolate the problem.

Note: The attention LEDs are amber and the power LEDs are green on the PCI-X board.

The following illustration shows the LEDs on the PCI-X board.

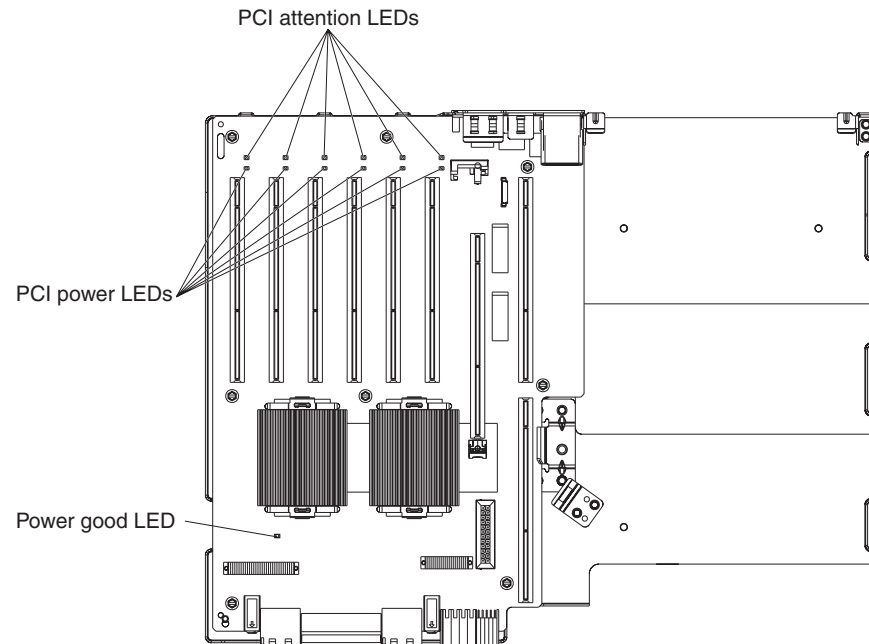

VRM LED

The VRM, CPU, and PCI-X BRD LEDs on the light path diagnostics panel might be lit at the same time if an installed VRM has failed. If the LEDs are lit and you are unable to isolate the error, first replace the installable VRMs (VRM3 and VRM4). Download and install the latest BMC code to correct the LED problem, when the code is available.

(xSeries 460 and xSeries MXE 460 server only) Power-control-button shield

A power-control-button shield comes with the server to prevent the server from being turned off accidentally. The shield might detach from the power-control button. Contact IBM to obtain a replacement power control-shield. See <http://www.ibm.com/planetwide/> for support telephone numbers.

Optional devices

This section contains information about optional devices.

ServeRAID-8i controller

This section contains information about the ServeRAID-8i controller.

ARCSAS.SYS device driver errors

The ServeRAID-8i ARCSAS.SYS device driver might produce red-bulleted errors in the Windows Server 2003 system event log. This error is informational only. Apply Service Pack 1 or higher to remove the ARCSAS.SYS device driver errors.

Availability of error logs

ServeRAID-8i error logs are available only from ServeRAID Manager with the operating system installed and with the ServeRAID Manager Agent running.

Command timeout error

If a command timeout error occurs during startup, replace the hard disk drive associated with the error.

Data loss with RAID level 5EE array

Attention: A problem has been found that might put data at risk in RAID level 5EE arrays during compaction and expansion cycles. Do not configure RAID level 5EE arrays until a fix for the problem is available. See <http://www.ibm.com/support/> and search for RETAIN Tip H184325 for further information.

Data scrubbing feature

On the ServeRAID-8i controller, the default setting for the data scrubbing feature is off. For maximum data protection, turn on this feature from either ServeRAID Manager within the operating system or from the *IBM ServeRAID Support CD*.

Drive assignments and front bezel bay IDs

Description: The ServeRAID-8i drive assignments in the ARCCONF GETCONFIG log or support archive might not correlate with the front bezel bay IDs. The ServeRAID-8i logs are incorrect, but ServeRAID Manager will correlate the bay IDs with the slots.

Solution: Before removing a drive, compare the hard disk drive serial numbers to verify that you have selected the correct disk, if you remove a hard disk drive based on ServeRAID-8i log information. The following illustration shows how the ServeRAID configuration logs correlate with the front bezel bay IDs:

Bay ID assignments
on front bezel

0	1	2
3	4	5

ServeRAID Manager hard disk
drive assignments

0	1	2
4	5	6

Logs fail to show drive array assignment

If you configure a RAID level 1 or RAID level 10 mirrored array, the ServeRAID Manager configuration logs (Raid1x.log) and the ARCCONF GETCONFIG log might fail to indicate which physical drives are mirrored. RAID level 5, RAID level 50, and other parity arrays indicate the stripe order in the logs.

Red Hat device drivers

ServeRAID-8i device drivers for the Red Hat Enterprise Linux operating system are currently not available. You can compile the ServeRAID-8i device driver from the *IBM ServeRAID Support CD*, when available. See the documentation provided on the *IBM ServeRAID Support CD* for instructions.

Replacement hard disk drives might not rebuild

Description: The ServeRAID-8i controller might fail to rebuild replacement hard disk drives when replaced in an array.

Solution: The following notes describe possible solutions:

- Remove the hard disk drive from the server, wait 30 seconds; then, replace the hard disk drive.
- Restart the server, remove the drive from the server, wait 30 seconds; then, replace the hard disk drive.
- Make sure that the SAS hard disk drive firmware version on the replacement hard disk drive and all other hard disk drives in the array is later than version 5.11. Contact IBM to obtain the SAS hard disk drive firmware update utility. See <http://www.ibm.com/planetwide/> for support telephone numbers.

SAS firmware update with ServeRAID-8i controller

SAS firmware cannot be updated with a ServeRAID-8i controller installed in the server. You must remove the ServeRAID-8i controller to update the SAS firmware.

POST error codes during initialization

Description: If the server is running a Linux operating system, error messages might occur during POST while the ServeRAID-8i controller initializes.

Solution: The following notes describe information that you must consider, if an error message occurs:

- If a kernel panic error occurs, debug the ServeRAID-8i controller and SAS subsystem. See the *Problem Determination and Service Guide* on the IBM *xSeries Documentation* CD for more information.
- A possible resolution is to remove the ServeRAID-8i controller from the server, restart the server, press F1 for the Configuration/Setup Utility program, and restore the factory settings. Then, reinstall the ServeRAID-8i controller and restart the server.

Supported options

For a list of supported options, go to <http://www.ibm.com/servers/eserver/serverproven/compat/us/>.

USB diskette drive

A USB diskette drive does not come with the server. If you must apply code updates using a diskette, you must provide a USB diskette drive. Obtain IBM part number 05K9276.

Problem determination

This section contains information about problem determination.

(Trained service technicians only) Checkpoint codes

Checkpoint codes give the check that was taking place at the time the system stopped; they do not provide error codes or suggested replacement parts. The checkpoint display will indicate where the server has stopped without waiting for the video to initialize at each startup during problem isolation.

There are two types of checkpoint codes: CPLD hardware checkpoint codes, and BIOS checkpoint codes. The BIOS checkpoint codes might change when the BIOS code is updated.

The checkpoint display is located on the I/O board.

Checkpoint codes can be found at <http://w3.pc.ibm.com/helpcenter/infotips/techinfo/MIGR-58350.html>.

DVD-ROM drive access

If you are unable to access the DVD-ROM drive, update the complex programmable logic device (CPLD) code with version 1.01, or later. To download the CPLD code, see <http://www.ibm.com/support/> and search for MIGR-60630.

Force power on jumper

Description: If the server does not turn on, see the section about power problems in the *Problem Determination and Service Guide* on the IBM *xSeries Documentation* CD. Also, see “Server fails to start” on page 19 of this document. In addition, you can bypass the operator information panel power-control button by using the force power on jumper (J2) on the I/O board. The following conditions might occur after you change the position of the jumper:

1. The server appears to power on and the fans spin.
2. The server halts at checkpoint 0b.
3. The monitor screen is blank.
4. The PCI-X board power good LED (CR11) is off.

Solution: Press the power-control button to turn on the server and resume the power-on sequence.

POST error code 001801nn

A 001801nn (where *nn* represents the PCI slot number) POST error code indicates a PCI device resource allocation error. Complete the following troubleshooting steps to resolve the condition:

- Disable the BIOS on all adapters that do not require booting. You can disable the integrated devices from the Configuration/Setup Utility program.
- Disable the BIOS of other adapters that might also use the ROM space, for example the Remote Supervisor Adapter II SlimLine.
- Load defaults in the SAS/SATA Configuration Utility program.
- Disable the PXE boot for the integrated Ethernet controller. Disable the PXE boot from the Configuration/Setup Utility program, if you choose to perform this troubleshooting step.
- Remove all network adapters from the startup sequence.
- Reallocate the boot order of the adapters so that the adapters with larger boot ROMs have more space to load.

For further instructions on resolving the condition, see <http://www.ibm.com/support/> and search for MIGR-59032.

Server fails to start

Complete the following troubleshooting steps, if the server fails to start:

1. If a Remote Supervisor Adapter II SlimLine is installed in the server, when you turn on the server for the first time, the server might appear to be unresponsive for an unusual length of time (one minute to several minutes). To solve the condition, when the server completes POST, flash the BIOS and BMC firmware to the latest levels. Then, flash update the Remote Supervisor Adapter II SlimLine. See <http://www.ibm.com/support/> and search for MIGR-59095 for further information.
2. Complete the following steps to replace the operator information panel ribbon cable:
 - a. Turn off the server.
 - b. Remove the white flex operator information panel ribbon cable from the I/O board and inspect the metal contacts for damage.
 - c. Replace the cable if the metal contacts are lifted from the cable or if there are signs of the metal being scraped.
 - d. See <http://www.ibm.com/support/> and search for MIGR-60141 for further information.
3. Over heated inductors at L14, L17, L28, L29, and L32 on the PCI-X board might cause power faults that will prevent the server from starting. See <http://www.ibm.com/support/> and search for RETAIN Tip H184310 for further information.

Remote Supervisor Adapter II SlimLine and BMC

This section contains information about the Remote Supervisor Adapter II SlimLine and BMC.

BMC log entries

The following notes describe information about the number of entries in the BMC log:

- The LOG LED on the light path diagnostics panel is lit when the BMC log is 75% full (370 entries).
- Depending on the server configuration, each ac power cycle results in about 30-50 entries. With a Remote Supervisor Adapter II SlimLine installed, the number of entries doubles at each ac power cycle.
- Each warm startup or Ctrl-Alt-Del startup results in four to seven entries.
- During initial setup or extensive problem determination activity, the BMC log can fill rapidly because ac power cycles are common when installing boards, microprocessors, DIMMs, and other components.
- No further entries can be written to the BMC log when it is full with 512 entries.
- To make sure that there is sufficient space for future events, clear the BMC log after you clear all conditions.

Note: Clearing the Remote Supervisor Adapter II SlimLine log does not clear the BMC log.

- See “Information LED” on page 14 for instructions on how to clear the BMC log.

Boot order communication

The server communicates boot order in the following sequence: BIOS, BMC, and the Remote Supervisor Adapter II SlimLine.

Cannot update Remote Supervisor Adapter II SlimLine IP address in BIOS

Description: After a Remote Supervisor Adapter II SlimLine is installed, you might not be able to change the IP address, subnet, or gateway from the Configuration/Setup Utility program.

Solution: Flash the Remote Supervisor Adapter II SlimLine to the latest available firmware level.

Communication failure and long POST

Description: If a Remote Supervisor Adapter II SlimLine is installed in the server, when you turn on the server for the first time, the server might appear to be unresponsive for an unusual length of time (one minute to several minutes).

Solution: When the server completes POST, flash the BIOS and BMC firmware to the latest available levels. Then, flash the Remote Supervisor Adapter II SlimLine firmware. See <http://www.ibm.com/support/> and search for MIGR-59095 for further information.

Additional symptoms might include a system halt at checkpoint c7, a 1602 communications POST error code, or both.

Error indicates microprocessor board bent pins

If the Redundant PCI Bridge Link Failed error message occurs in the BMC log or system-event log, check the microprocessor board for bent pins. If you are unable to straighten the pins, replace the microprocessor board (trained service technician only).

Firmware updates

The following notes describe information that you must consider when updating the Remote Supervisor Adapter II SlimLine and BMC firmware:

- To remotely update the Remote Supervisor Adapter II SlimLine, log in to the Remote Supervisor Adapter II Web-based interface from the following IP address: 192.168.70.125 subnet 255.255.255.0 or through Windows using Wflash or Linux using Lflash. The default network setting on a Remote Supervisor Adapter II SlimLine is DHCP. If the adapter is unable to obtain a valid IP address, it will use the default static IP address.
- Update the BMC firmware from the UpdateExpress program or from a flash update diskette.

Remote Supervisor Adapter II SlimLine and BMC troubleshooting tips

The following resources are available for troubleshooting the Remote Supervisor Adapter II SlimLine and baseboard management controller:

- Use the SMBridge utility to retrieve BMC data remotely. The default IP address for the BMC is 10.1.1.97 subnet 255.255.255.0. To download the utility and for instructions on how to use the utility, see <http://www.ibm.com/support/> and search for MIGR-57729.
- Use the Syscon utility to retrieve BMC log data. The utility differs slightly from the SMBridge utility. Contact IBM to obtain this utility, if needed. See <http://www.ibm.com/planetwide/> for support telephone numbers.
- Contact IBM to have the BMC log data analyzed. See <http://www.ibm.com/planetwide/> for support telephone numbers.

Remote Supervisor Adapter II SlimLine might fail on ac power cycle

After an ac power cycle (ac power is removed and reapplied to the server), the Remote Supervisor Adapter II SlimLine might not log events for two or three minutes in the system-event log when indicated from the BMC. Wait two or three minutes before you press the power-on button and the Remote Supervisor Adapter II SlimLine will record BMC-indicated events during the power on sequence.

If problem determination activity is in progress and you cannot start the server, wait two or three minutes before you press the power-control button; then, view the BMC log and system-event log.

Remote Supervisor Adapter II SlimLine network access delay

The default network setting on a Remote Supervisor Adapter II SlimLine is DHCP. If the adapter is unable to obtain a valid IP address, it will use the default static IP address. There might be a three to four minute delay in network access to the adapter each time the adapter is restarted. During this time, the Remote Supervisor Adapter II SlimLine is searching for an IP address from a DHCP server. Set the static IP address, if the adapter is not using DHCP.

Note: The default static IP address is 192.168.70.125.

Software

This section contains information about software.

Broadcom Gigabyte Ethernet controller default settings

The server comes with an integrated Broadcom 5704C dual Gigabit Ethernet controller, which supports connection to a 10-Mbps, 100-Mbps, or 1000-Mbps network. The following notes describe information that you must consider regarding the default settings of the controller:

- The default setting on the controller is Auto-Negotiate, and the controller should link at the speed of the switch when the server is turned on. When in Stand-by mode, the speed setting reduces to 10-Mbps/100-Mbps, which is the default for the IPMI link (into the BMC).
- 1000-Mbps IPMI (BMC) communications has not been tested and is not supported.

Firmware updates

IBM will periodically make firmware updates available for the servers. Firmware updates are available from <http://www.ibm.com/support/>. Updating the firmware can solve many problems with the server.

IBM Director

IBM Director is a workgroup-hardware-management tool that you can use to centrally manage your IBM servers. IBM Director code updates might be required to support xSeries 260, xSeries 366, and xSeries 460 servers. See <http://www.ibm.com/support/> to download the program updates.

PCI scan sequence

The server scans devices and PCI-X slots to assign system resources in the following order: integrated Ethernet controller, integrated SAS controller, and then PCI and PCI-X slots 1 through 6.

To change the order in which the server scans devices and PCI-X slots, start the Configuration/Setup Utility program and select **Start Options** from the main menu.

The start options settings specify the scan order in which the server checks devices to find a boot record. The server starts from the first boot record that it finds.

SAS Windows 2000 Server device driver

Description: A SCSI (SAS) device driver that is not available on the Windows 2000 Server installation CD is required for the remote installation of Windows 2000 Server.

Solution: Use a version of Windows 2000 Server that includes at least Service Pack 3. See the Microsoft Knowledge Base article 302098 ("INACCESSIBLE_BOOT_DEVICE" Message After Changing a SCSI Adapter Resource).

Support telephone numbers

View support telephone numbers at <http://www.ibm.com/planetwide/>.

Chapter 3. Getting help and technical assistance

If you need help, service, or technical assistance or just want more information about IBM products, you will find a wide variety of sources available from IBM to assist you. This appendix contains information about where to go for additional information about IBM and IBM products, what to do if you experience a problem with your @server[®] or IntelliStation[®] system or optional device, and whom to call for service, if it is necessary.

Before you call

Before you call, make sure that you have taken these steps to try to solve the problem yourself:

- Check all cables to make sure that they are connected.
- Check the power switches to make sure that the system and any optional devices are turned on.
- Use the troubleshooting information in your system documentation, and use the diagnostic tools that come with your system. Information about diagnostic tools is in the *Hardware Maintenance Manual and Troubleshooting Guide* or *Problem Determination and Service Guide* on the IBM Documentation CD that comes with your system.

Note: For some IntelliStation models, the *Hardware Maintenance Manual and Troubleshooting Guide* is available only from the IBM support Web site.

- Go to the IBM support Web site at <http://www.ibm.com/support/> to check for technical information, hints, tips, and new device drivers or to submit a request for information.
- Go to <http://www.ibm.com/support/> to check for the latest level of all firmware for the server. Updating the firmware can solve many problems with the server.

You can solve many problems without outside assistance by following the troubleshooting procedures that IBM provides in the online help or in the documentation that is provided with your IBM product. The documentation that comes with @server and IntelliStation systems also describes the diagnostic tests that you can perform. Most @server and IntelliStation systems, operating systems, and programs come with documentation that contains troubleshooting procedures and explanations of error messages and error codes. If you suspect a software problem, see the documentation for the operating system or program.

Using the documentation

Information about your IBM @server or IntelliStation system and preinstalled software, if any, or optional device is available in the documentation that comes with the product. That documentation can include printed documents, online documents, readme files, and help files. See the troubleshooting information in your system documentation for instructions for using the diagnostic programs. The troubleshooting information or the diagnostic programs might tell you that you need additional or updated device drivers or other software. IBM maintains pages on the World Wide Web where you can get the latest technical information and download device drivers and updates. To access these pages, go to <http://www.ibm.com/support/> and follow the instructions. Also, some documents are available through the IBM Publications Ordering System at <http://www.elink.ibm.com/public/applications/publications/cgibin/pbi.cgi>.

Getting help and information from the World Wide Web

On the World Wide Web, the IBM Web site has up-to-date information about IBM @server and IntelliStation systems, optional devices, services, and support. The address for IBM xSeries and BladeCenter® information is <http://www.ibm.com/eserver/xseries/>. The address for IBM IntelliStation information is <http://www.ibm.com/intellistation/>.

You can find service information for IBM systems and optional devices at <http://www.ibm.com/support/>.

Software service and support

Through IBM Support Line, you can get telephone assistance, for a fee, with usage, configuration, and software problems with xSeries servers, BladeCenter products, IntelliStation workstations, and appliances. For information about which products are supported by Support Line in your country or region, see <http://www.ibm.com/services/sl/products/>.

For more information about Support Line and other IBM services, see <http://www.ibm.com/services/>, or see <http://www.ibm.com/planetwide/> for support telephone numbers. In the U.S. and Canada, call 1-800-IBM-SERV (1-800-426-7378).

Hardware service and support

You can receive hardware service through IBM Services or through your IBM reseller, if your reseller is authorized by IBM to provide warranty service. See <http://www.ibm.com/planetwide/> for support telephone numbers, or in the U.S. and Canada, call 1-800-IBM-SERV (1-800-426-7378).

In the U.S. and Canada, hardware service and support is available 24 hours a day, 7 days a week. In the U.K., these services are available Monday through Friday, from 9 a.m. to 6 p.m.

Appendix A. xSeries 260 model PAE

This section contains installation and troubleshooting hints and tips related to the xSeries 260 Type 8865 model PAE server:

Bezel and hard disk drive cage replacement

If you must replace either the bezel or the hard disk drive cage, replace both the bezel (FRU 26R0775) and the hard drive cage (FRU 26R0773).

Hard disk drives

The following section describes information about hard disk drives.

Support

The server as shipped supports only 10 000 RPM hard disk drives.

Closing the tray handle during installation

When installing a hard disk drive, you might experience difficulty closing the tray handle.

Complete the following steps if you experience difficulty closing the tray handle:

1. Remove the hard disk drive from the drive bay.
2. Reinstall the drive in the drive bay and firmly close the tray handle.

Tray alignment

Hard disk drives might align incorrectly in the drive bay during installation and not seat fully in the drive bay.

Complete the following steps to make sure that the hard disk drives align correctly in the drive bay:

1. Remove the hard disk drive from the drive bay.
2. If unoccupied, install a filler panel in the drive bay below the drive bay in which you are installing the drive.
3. Reinstall the hard disk drive in the drive bay.

Removal

Note: To prevent bezel interference with hard disk drive removal, press on the front of the bezel to the left of the hard disk drive handle while you remove the drive. Alternatively, remove the bezel before you remove a hard disk drive.

The bezel might interfere with hard disk drive removal.

The following notes describe possible solutions:

- If the hard disk drive is partially installed and the hard disk drive handle is caught between the bezel and the chassis, close the handle to release the handle from behind the bezel.
- Remove the bezel and remove the hard disk drive; then, reinstall the bezel.

SAS hard disk drives auto-negotiate 1.5 GB/ps transfer speed

The SAS hard disk drives negotiate 1.5 GB/ps transfer speed after exiting the SAS/SATA Configuration Utility program (accessed by pressing Ctrl+A during startup).

Performance is not affected by the 1.5 GB/ps transfer speed because the speed supports the maximum throughput for the current SAS hard disk drives. Maintain the 1.5 GB/ps setting. A future version of the SAS BIOS code will contain a fix to enable updating the transfer speed setting.

Appendix B. Notices

This information was developed for products and services offered in the U.S.A.

IBM may not offer the products, services, or features discussed in this document in other countries. Consult your local IBM representative for information on the products and services currently available in your area. Any reference to an IBM product, program, or service is not intended to state or imply that only that IBM product, program, or service may be used. Any functionally equivalent product, program, or service that does not infringe any IBM intellectual property right may be used instead. However, it is the user's responsibility to evaluate and verify the operation of any non-IBM product, program, or service.

IBM may have patents or pending patent applications covering subject matter described in this document. The furnishing of this document does not give you any license to these patents. You can send license inquiries, in writing, to:

*IBM Director of Licensing
IBM Corporation
North Castle Drive
Armonk, NY 10504-1785
U.S.A.*

INTERNATIONAL BUSINESS MACHINES CORPORATION PROVIDES THIS PUBLICATION "AS IS" WITHOUT WARRANTY OF ANY KIND, EITHER EXPRESS OR IMPLIED, INCLUDING, BUT NOT LIMITED TO, THE IMPLIED WARRANTIES OF NON-INFRINGEMENT, MERCHANTABILITY OR FITNESS FOR A PARTICULAR PURPOSE. Some states do not allow disclaimer of express or implied warranties in certain transactions, therefore, this statement may not apply to you.

This information could include technical inaccuracies or typographical errors. Changes are periodically made to the information herein; these changes will be incorporated in new editions of the publication. IBM may make improvements and/or changes in the product(s) and/or the program(s) described in this publication at any time without notice.

Any references in this information to non-IBM Web sites are provided for convenience only and do not in any manner serve as an endorsement of those Web sites. The materials at those Web sites are not part of the materials for this IBM product, and use of those Web sites is at your own risk.

IBM may use or distribute any of the information you supply in any way it believes appropriate without incurring any obligation to you.

Edition notice

© Copyright International Business Machines Corporation 2005. All rights reserved.

U.S. Government Users Restricted Rights — Use, duplication, or disclosure restricted by GSA ADP Schedule Contract with IBM Corp.

Trademarks

The following terms are trademarks of International Business Machines Corporation in the United States, other countries, or both:

Active Memory	Predictive Failure Analysis
Active PCI	PS/2
Active PCI-X	ServeRAID
Alert on LAN	ServerGuide
BladeCenter	ServerProven
C2T Interconnect	TechConnect
Chipkill	ThinkPad
EtherJet	Tivoli
e-business logo	Tivoli Enterprise
@server	Update Connector
FlashCopy	Wake on LAN
IBM	XA-32
IBM (logo)	XA-64
IntelliStation	X-Architecture
NetBAY	Xcel4
Netfinity	XpandOnDemand
NetView	xSeries
OS/2 WARP	

Intel, MMX, and Pentium are trademarks of Intel Corporation in the United States, other countries, or both.

Microsoft, Windows, and Windows NT are trademarks of Microsoft Corporation in the United States, other countries, or both.

UNIX is a registered trademark of The Open Group in the United States and other countries.

Java and all Java-based trademarks and logos are trademarks of Sun Microsystems, Inc. in the United States, other countries, or both.

Adaptec and HostRAID are trademarks of Adaptec, Inc., in the United States, other countries, or both.

Linux is a trademark of Linus Torvalds in the United States, other countries, or both.

Red Hat, the Red Hat "Shadow Man" logo, and all Red Hat-based trademarks and logos are trademarks or registered trademarks of Red Hat, Inc., in the United States and other countries.

Other company, product, or service names may be trademarks or service marks of others.

Important notes

Processor speeds indicate the internal clock speed of the microprocessor; other factors also affect application performance.

CD-ROM drive speeds list the variable read rate. Actual speeds vary and are often less than the maximum possible.

When referring to processor storage, real and virtual storage, or channel volume, KB stands for approximately 1000 bytes, MB stands for approximately 1 000 000 bytes, and GB stands for approximately 1 000 000 000 bytes.

When referring to hard disk drive capacity or communications volume, MB stands for 1 000 000 bytes, and GB stands for 1 000 000 000 bytes. Total user-accessible capacity may vary depending on operating environments.

Maximum internal hard disk drive capacities assume the replacement of any standard hard disk drives and population of all hard disk drive bays with the largest currently supported drives available from IBM.

Maximum memory may require replacement of the standard memory with an optional memory module.

IBM makes no representation or warranties regarding non-IBM products and services that are ServerProven[®], including but not limited to the implied warranties of merchantability and fitness for a particular purpose. These products are offered and warranted solely by third parties.

IBM makes no representations or warranties with respect to non-IBM products. Support (if any) for the non-IBM products is provided by the third party, not IBM.

Some software may differ from its retail version (if available), and may not include user manuals or all program functionality.



Part Number: 31R1507

Printed in USA

(1P) P/N: 31R1507

