

IBM IntelliStation M Pro
Type 6218



User's Guide

IBM IntelliStation M Pro
Type 6218



User's Guide

Note:

Before using this information and the product it supports, read the information in Appendix B, "Notices," on page 77.

First Edition (September 2005)

© Copyright International Business Machines Corporation 2005. All rights reserved.

US Government Users Restricted Rights – Use, duplication or disclosure restricted by GSA ADP Schedule Contract with IBM Corp.

Contents

Safety	vii
Chapter 1. Introducing the IntelliStation M Pro computer	1
Related documentation	1
Notices and statements in this document	3
Features and specifications	4
What the computer offers	5
Software	5
Preinstalled software	6
Software on CD	7
Software available on the World Wide Web	7
Reliability, availability, and serviceability features	8
Chapter 2. Operating the computer	9
Controls and LEDs	9
Turning on the computer	10
Using preinstalled software	12
Running the operating-system setup program	12
Installing other operating systems	12
Viewing the license agreement	13
Registering the computer	13
Creating an emergency recovery-repair diskette in Windows	13
Creating an IBM Enhanced Diagnostics Diskette or CD in Windows	14
Using video features	15
Video device drivers	15
Changing monitor settings	16
Using audio features	16
Using security features	17
Anti-intrusion features	17
Component protection	17
Data protection	17
Locking the keyboard	17
Updating system programs	18
Managing the computer	18
Shutting down the operating system	19
Turning off the computer	19
Chapter 3. Configuring the computer	21
Using the Configuration/Setup Utility program	22
Starting the Configuration/Setup Utility program	22
Configuration/Setup Utility menu choices	22
Using passwords	24
Using the Boot Menu program	25
Enabling the Broadcom NetXtreme Gigabit Ethernet Boot Agent	26
Using the Adaptec HostRAID configuration programs	26
Using the Adaptec RAID Configuration Utility program (for SATA RAID)	27
Using the SCSISelect Utility program (for SCSI RAID)	28
Using the SAS/SATA Configuration Utility (for Serial Attached SCSI RAID)	29
Using ServeRAID Manager	30
Configuring the controller	30
Viewing the configuration	31
Configuring the Broadcom NetXtreme Gigabit Ethernet controller	32
Using the SCSISelect Utility program (some models)	32

Starting the SCSISelect Utility program	32
SCSISelect menu choices	32
Chapter 4. Installing options	35
Installation guidelines	35
System reliability considerations	35
Handling static-sensitive devices	36
Major components of the computer	37
System-board option connectors	38
System-board internal connectors and jumpers	39
System-board external connectors	40
Removing the side cover	41
Removing the bezel	42
Removing the internal drive-bay bracket	43
Removing the air baffle	44
Installing an adapter	45
Cabling an optional SCSI adapter	48
Installing internal drives	49
Installing memory modules	62
Installing a security cable	64
Replacing the air baffle	64
Replacing the internal drive-bay bracket	65
Replacing the bezel	66
Replacing the side cover	67
Connecting external options	67
Input/output connectors	68
Audio connectors	68
Auxiliary-device (pointing-device) connector	69
Ethernet (RJ-45) connector	69
IEEE 1394 (FireWire) connector (some models)	69
Keyboard connector	70
Parallel connector	70
Serial connectors	70
Ultra320 SCSI connector	71
Universal Serial Bus connectors	72
Video connector	72
Appendix A. Getting help and technical assistance	75
Before you call	75
Using the documentation	75
Getting help and information from the World Wide Web	76
Software service and support	76
Hardware service and support	76
Appendix B. Notices	77
Edition notice	77
Trademarks	78
Important notes	78
Product recycling and disposal	79
Battery return program	80
Electronic emission notices	81
Federal Communications Commission (FCC) statement	81
Industry Canada Class B emission compliance statement	81
Avis de conformité à la réglementation d'Industrie Canada	81
European Union EMC Directive conformance statement	81
Japanese Voluntary Control Council for Interference (VCCI) statement	82

Power cords	82
Index	85

Safety

Before installing this product, read the Safety Information.

قبل تركيب هذا المنتج، يجب قراءة الملاحظات الأمنية

Antes de instalar este produto, leia as Informações de Segurança.

在安装本产品之前，请仔细阅读 **Safety Information** (安全信息)。

安裝本產品之前，請先閱讀「安全資訊」。

Prije instalacije ovog produkta obavezno pročitajte Sigurnosne Upute.

Před instalací tohoto produktu si přečtěte příručku bezpečnostních instrukcí.

Læs sikkerhedsforskrifterne, før du installerer dette produkt.

Lees voordat u dit product installeert eerst de veiligheidsvoorschriften.

Ennen kuin asennat tämän tuotteen, lue turvaohjeet kohdasta Safety Information.

Avant d'installer ce produit, lisez les consignes de sécurité.

Vor der Installation dieses Produkts die Sicherheitshinweise lesen.

Πριν εγκαταστήσετε το προϊόν αυτό, διαβάστε τις πληροφορίες ασφάλειας (safety information).

לפני שתתקינו מוצר זה, קראו את הוראות הבטיחות.

A termék telepítése előtt olvassa el a Biztonsági előírásokat!

Prima di installare questo prodotto, leggere le Informazioni sulla Sicurezza.

製品の設置の前に、安全情報をお読みください。

본 제품을 설치하기 전에 안전 정보를 읽으십시오.

Пред да се инсталира овој продукт, прочитајте информацијата за безбедност.

Les sikkerhetsinformasjonen (Safety Information) før du installerer dette produktet.

Przed zainstalowaniem tego produktu, należy zapoznać się z książką "Informacje dotyczące bezpieczeństwa" (Safety Information).

Antes de instalar este produto, leia as Informações sobre Segurança.

Перед установкой продукта прочтите инструкции по технике безопасности.

Pred inštaláciou tohto zariadenia si pečítajte Bezpečnostné predpisy.

Pred namestitvijo tega proizvoda preberite Varnostne informacije.

Antes de instalar este producto, lea la información de seguridad.

Läs säkerhetsinformationen innan du installerar den här produkten.

Statement 1:



DANGER

Electrical current from power, telephone, and communication cables is hazardous.

To avoid a shock hazard:

- Do not connect or disconnect any cables or perform installation, maintenance, or reconfiguration of this product during an electrical storm.
- Connect all power cords to a properly wired and grounded electrical outlet.
- Connect to properly wired outlets any equipment that will be attached to this product.
- When possible, use one hand only to connect or disconnect signal cables.
- Never turn on any equipment when there is evidence of fire, water, or structural damage.
- Disconnect the attached power cords, telecommunications systems, networks, and modems before you open the device covers, unless instructed otherwise in the installation and configuration procedures.
- Connect and disconnect cables as described in the following table when installing, moving, or opening covers on this product or attached devices.

To Connect:

1. Turn everything OFF.
2. First, attach all cables to devices.
3. Attach signal cables to connectors.
4. Attach power cords to outlet.
5. Turn device ON.

To Disconnect:

1. Turn everything OFF.
2. First, remove power cords from outlet.
3. Remove signal cables from connectors.
4. Remove all cables from devices.

Statement 2:



CAUTION:

When replacing the lithium battery, use only IBM Part Number 33F8354 or an equivalent type battery recommended by the manufacturer. If your system has a module containing a lithium battery, replace it only with the same module type made by the same manufacturer. The battery contains lithium and can explode if not properly used, handled, or disposed of.

Do not:

- Throw or immerse into water
- Heat to more than 100°C (212°F)
- Repair or disassemble

Dispose of the battery as required by local ordinances or regulations.

Statement 3:



CAUTION:

When laser products (such as CD-ROMs, DVD drives, fiber optic devices, or transmitters) are installed, note the following:

- Do not remove the covers. Removing the covers of the laser product could result in exposure to hazardous laser radiation. There are no serviceable parts inside the device.
- Use of controls or adjustments or performance of procedures other than those specified herein might result in hazardous radiation exposure.



DANGER

Some laser products contain an embedded Class 3A or Class 3B laser diode. Note the following.

Laser radiation when open. Do not stare into the beam, do not view directly with optical instruments, and avoid direct exposure to the beam.

Statement 4:



≥ 18 kg (39.7 lb)



≥ 32 kg (70.5 lb)

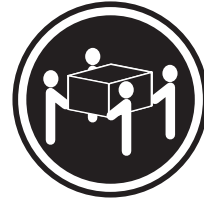

≥ 55 kg (121.2 lb)

CAUTION:

Use safe practices when lifting.

Statement 5:



CAUTION:

The power control button on the device and the power switch on the power supply do not turn off the electrical current supplied to the device. The device also might have more than one power cord. To remove all electrical current from the device, ensure that all power cords are disconnected from the power source.

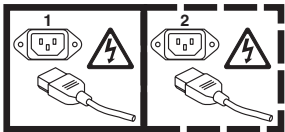

Statement 8:



CAUTION:

Never remove the cover on a power supply or any part that has the following label attached.



Hazardous voltage, current, and energy levels are present inside any component that has this label attached. There are no serviceable parts inside these components. If you suspect a problem with one of these parts, contact a service technician.

WARNING: Handling the cord on this product or cords associated with accessories sold with this product, will expose you to lead, a chemical known to the State of California to cause cancer, and birth defects or other reproductive harm. ***Wash hands after handling.***

ADVERTENCIA: El contacto con el cable de este producto o con cables de accesorios que se venden junto con este producto, pueden exponerle al plomo, un elemento químico que en el estado de California de los Estados Unidos está considerado como un causante de cancer y de defectos congénitos, además de otros riesgos reproductivos. ***Lávese las manos después de usar el producto.***

Important:

All caution and danger statements in this documentation begin with a number. This number is used to cross reference an English caution or danger statement with translated versions of the caution or danger statement in the *IBM Safety Information* document.

For example, if a caution statement begins with a number 1, translations for that caution statement appear in the *IBM Safety Information* document under statement 1.

Be sure to read all caution and danger statements in this documentation before performing the instructions. Read any additional safety information that comes with your server or optional device before you install the device.

Important:

This computer is suitable for use on an IT power distribution system, whose maximum phase to phase voltage is 240 V under any distribution fault condition.

Chapter 1. Introducing the IntelliStation M Pro computer

The IBM® IntelliStation® M Pro Type 6218 computer incorporates many of the latest advances in computing technology and can be expanded and upgraded as your needs change.

You can obtain up-to-date information about the computer and other IBM computer products at <http://www.ibm.com/intellistation/>.

The computer model and serial numbers for the M Pro Type 6218 are on labels on the bottom of the computer and on the lower-right side of the bezel. You will need these numbers to register the computer with IBM.

Note: The illustrations in this document might differ slightly from your hardware.

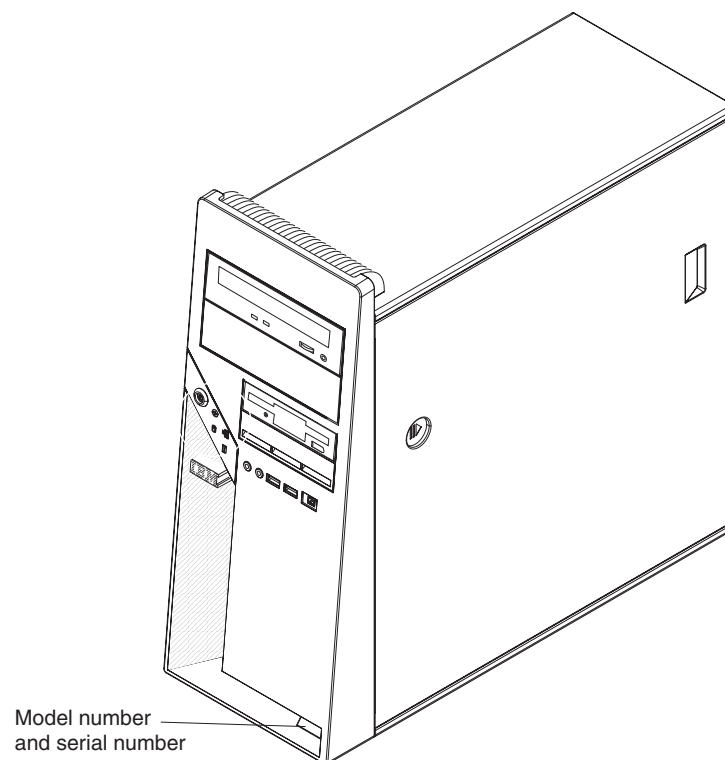

Related documentation

This *User's Guide* provides general information about the computer, including information about features, how to configure the computer, how to install options, and how to solve problems and get help. In addition to this *User's Guide*, the following documentation comes with the computer:

- *Installation Guide*

This printed document contains setup and installation instructions.

- *Problem Determination and Service Guide*

This document is on the *IntelliStation Documentation CD* and at <http://www.ibm.com/support/>. This document contains information to help you solve problems that might occur in the computer.

- *Safety Information*

This document is in PDF on the IBM *IntelliStation Documentation* CD. It contains translated caution and danger statements. Each caution and danger statement that appears in the documentation has a number that you can use to locate the corresponding statement in your language in the *Safety Information* document.

- *Warranty and Support Information*

This document is in PDF on the IBM *IntelliStation Documentation* CD. It contains information about the terms of the warranty and about services and assistance.

- *Adaptec SCSI documentation*

This document is in PDF on the *Device Drivers* CD. It contains information and instructions for installing and configuring small computer system interface (SCSI) device drivers and devices.

- Readme files on the *Device Drivers* CD

Several readme files on the CD contain information about preinstalled device drivers. Other readme files on the CD contain information about the various adapters and devices that might be installed in or attached to the computer.

- *IBM IntelliStation Documentation* CD

This CD contains all of the IBM IntelliStation M Pro Type 6218 documents in Portable Document Format (PDF). Depending on the computer model, additional documentation might be included on the IBM *IntelliStation Documentation* CD.

The computer might have features that are not described in the documentation that you received with the computer. The documentation might be updated occasionally to include information about those features, or technical updates might be available to provide additional information. These updates are available from the IBM Web site. To check for updated documentation and technical updates, complete the following steps:

Note: Changes are made periodically to the IBM Web site. The actual procedure might vary slightly from what is described in this document.

1. Go to <http://www.ibm.com/support/>.
2. In the **Browse by topic** section, click **Publications**.
3. On the Publications page, in the **Brand** field, select **IntelliStation**.
4. In the **Family** field, select **IntelliStation M Pro**.
5. In the **Type** field, select **6218**.
6. Click **Continue**.

Notices and statements in this document

The caution and danger statements that appear in this document are also in the multilingual *Safety Information* document, which is on the IBM *IntelliStation Documentation CD*. Each statement is numbered for reference to the corresponding statement in the *Safety Information* document.

The following notices and statements are used in this document:

- **Note:** These notices provide important tips, guidance, or advice.
- **Important:** These notices provide information or advice that might help you avoid inconvenient or problem situations.
- **Attention:** These notices indicate potential damage to programs, devices, or data. An attention notice is placed just before the instruction or situation in which damage could occur.
- **Caution:** These statements indicate situations that can be potentially hazardous to you. A caution statement is placed just before the description of a potentially hazardous procedure step or situation.
- **Danger:** These statements indicate situations that can be potentially lethal or extremely hazardous to you. A danger statement is placed just before the description of a potentially lethal or extremely hazardous procedure step or situation.

Features and specifications

The following table provides a summary of the features and specifications of the computer. Depending on the model, some features might not be available, or some specifications might not apply. Use the Configuration/Setup Utility program to determine the type and speed of the microprocessor.

Table 1. Features and specifications

<p>Microprocessor:</p> <ul style="list-style-type: none"> Intel™ Pentium 4 processor 2 MB Level-2 cache 800 MHz front-side bus (FSB) <p>Memory:</p> <ul style="list-style-type: none"> Minimum: 1GB Maximum: 8 GB Type: PC2-4200, dual-data-rate 2 (DDR2) un-buffered error correcting code (ECC) Connectors: four dual inline memory module (DIMM) connectors <p>Internal drives:</p> <ul style="list-style-type: none"> Diskette: 1.44 MB (two mode) (optional) Hard disk drive: SATA, SCSI, or SAS One of the following drives: <ul style="list-style-type: none"> DVD/CD-RW combo: IDE CD-RW: IDE <p>Expansion bays:</p> <ul style="list-style-type: none"> One slim-high 3.5-inch external drive bay (optional) Two half-high 5.25-inch bays (optical drive installed in one bay) Two slim-high 3.5-inch internal drive bays (one hard disk drive installed) <p>PCI expansion slots:</p> <ul style="list-style-type: none"> One PCI Express x1 slot One PCI Express x8 slot (x4 electrical) One PCI Express x16 slot (support x16 video cards only) One 33 MHz/32-bit PCI slot <p>Power supply:</p> <p>One 400-watts (115-230 V ac)</p> <p>Cooling:</p> <ul style="list-style-type: none"> One speed-controlled fan and one power supply fan 	<p>Integrated functions:</p> <ul style="list-style-type: none"> Broadcom 5721 10/100/1000 Ethernet controller with RJ-45 Ethernet connector Single-channel SCSI provided by a mini-PCI card Two serial connectors One parallel connector Three-port serial ATA controller Two IEEE 1394 (FireWire) ports (four-pin on front, six-pin on rear) Eight Universal Serial Bus (USB) connectors (two on front and six on rear) Keyboard connector Mouse connector Audio connectors <ul style="list-style-type: none"> Line out (front and rear) Mic (front) Line in (rear) Single-channel IDE controller <p>Video adapter: (depending on the model)</p> <ul style="list-style-type: none"> NVIDIA Quadro NVS 280 (DMS-59), PCI Express x16, with 64 MB DDR synchronous dynamic random access memory (SDRAM) video memory and dual analog connectors (or dual digital monitor capability with the purchase of an additional pigtail cable) ATI FireGL V3100 (DVI-I), PCI Express x16, with 128 MB DDR SDRAM video memory with dual DVI-I and VGA connectors NVIDIA FX 1400 (DVI-I), PCI Express x16, with 128 MB DDR SDRAM video memory with dual DVI-I connectors ATI FireGL V7100 (DVI-I), PCI Express x16, with 256 MB GDDR3 SDRAM video memory with dual DVI-I connectors 3DLabs Wildcat Realizm 800 (DVI-I), PCI Express x16, with 512 MB GDDR3 (512-bit Unified) and 128 MB GDDR3 (128-bit direct burst) SDRAM video memory with dual DVI-I connectors 	<p>Electrical input:</p> <ul style="list-style-type: none"> Sine-wave input (50 or 60 Hz) required Input voltage and frequency ranges automatically selected Input voltage low range: <ul style="list-style-type: none"> Minimum: 90 V ac Maximum: 137 V ac Input voltage high range: <ul style="list-style-type: none"> Minimum: 180 V ac Maximum: 265 V ac Input kilovolt-amperes (kVA) approximately: <ul style="list-style-type: none"> Minimum: 0.12 kVA Maximum: 0.58 kVA <p>Heat output:</p> <p>Approximate heat output in British thermal units (Btu) per hour:</p> <ul style="list-style-type: none"> Minimum configuration: 433 Btu (127 watts) per hour Maximum configuration: 1948 Btu (571 watts) per hour <p>Environment:</p> <ul style="list-style-type: none"> Air temperature: <ul style="list-style-type: none"> Computer on: 10° to 35°C (50° to 95°F) Altitude: 0 to 2134 m (7000 ft) Computer off: -40° to +60°C (-40° to +140°F) Maximum altitude: 2133 m (7000 ft) Humidity (operating and storage): 8% to 80% <p>Acoustical noise emissions:</p> <ul style="list-style-type: none"> Sound power, idle: 4.3 bel Sound power, operating: 4.9 bel <p>Size:</p> <ul style="list-style-type: none"> Height: 435 mm (17.12 in.) Depth: 445 mm (17.5 in.) Width: 178 mm (7 in.) Weight: 10.5 kg (23 lb) to 13.5 kg (30 lb) depending upon configuration
-----------------------------------------------------------------------------------------------------------------------------------------------------------------------------------------------------------------------------------------------------------------------------------------------------------------------------------------------------------------------------------------------------------------------------------------------------------------------------------------------------------------------------------------------------------------------------------------------------------------------------------------------------------------------------------------------------------------------------------------------------------------------------------------------------------------------------------------------------------------------------------------------------------------------------------------------------------------------------------------------------------------------------------------------------------------------------------------------------------------------------------------------------------------------------------------------------------------------------------------------------------------------------------------------------------------------------------------------------------------------------------------------------------------------------------------------------------------------------------------------------------------------------------	-------------------------------------------------------------------------------------------------------------------------------------------------------------------------------------------------------------------------------------------------------------------------------------------------------------------------------------------------------------------------------------------------------------------------------------------------------------------------------------------------------------------------------------------------------------------------------------------------------------------------------------------------------------------------------------------------------------------------------------------------------------------------------------------------------------------------------------------------------------------------------------------------------------------------------------------------------------------------------------------------------------------------------------------------------------------------------------------------------------------------------------------------------------------------------------------------------------------------------------------------------------------------------------------------------------------------------------------------------------------------------------------------------------------------------------------------------------------------------------------------------------------------------------------------------------------------------------------------------------------------------------------------------------------	--------------------------------------------------------------------------------------------------------------------------------------------------------------------------------------------------------------------------------------------------------------------------------------------------------------------------------------------------------------------------------------------------------------------------------------------------------------------------------------------------------------------------------------------------------------------------------------------------------------------------------------------------------------------------------------------------------------------------------------------------------------------------------------------------------------------------------------------------------------------------------------------------------------------------------------------------------------------------------------------------------------------------------------------------------------------------------------------------------------------------------------------------------------------------------------------------------------------------------------------------------------------------------------------------------------------------------------------------------------------------------------------------------------------------------------------------------------------------------------------------------------------------------------------------------------------------------------------------------------------------------------------------------------------------------------------------------

What the computer offers

The computer uses the following features and technologies:

- **PCI Express x16 graphics**

The computer comes with a graphics adapter installed in the PCI Express x16 slot (slot 2). This high-performance adapter supports high resolutions and includes many performance-enhancing features for the operating-system environment.

- **Large system-memory capacity**

The computer supports up to 8.0 GB of system memory. The memory controller provides ECC support for up to four industry-standard PC2-4200, 1.8 V, 240-pin, unbuffered, double-data-rate 2 (DDR2), synchronous dynamic random access memory (SDRAM) dual inline memory modules (DIMMs).

- **Systems-management capabilities**

The computer comes with features that a network administrator or file server can use to remotely manage and control the computer. These features include Wake on LAN[®], Remote Administration, IBM Director Agent, and System Migration Assistant. See “Managing the computer” on page 18 for more information.

- **Integrated network support**

The computer comes with an integrated Ethernet controller, which supports connection to a 10-Mbps, 100-Mbps, or 1-Gbps network. For more information, see “Configuring the Broadcom NetXtreme Gigabit Ethernet controller” on page 32. The controller supports Wake on LAN technology.

Software

The IBM IntelliStation M Pro computer comes with Microsoft Windows[®] XP Professional or Red Hat Enterprise Linux Workstation preinstalled and a variety of software, including application programs, diagnostic tools, and device drivers.

Important: The software, other than the operating system, is licensed under the terms of the IBM International License Agreement for Non-Warranted Programs. Use of the computer signifies acceptance of this license agreement. For detailed instructions for viewing the license agreement, see “Viewing the license agreement” on page 13.

Preinstalled software

In addition to the operating system, the preinstalled software includes some or all of the following programs. Some programs might require setup and configuration before use.

- **Adobe Acrobat Reader**

You can use this program to read files in PDF, including the online documentation. You can download the most current versions of Adobe Acrobat Reader for other languages and operating systems from the Adobe Web site at <http://www.adobe.com>.

- **Device Drivers**

Device drivers for factory-installed features are preinstalled on the computer. The latest device drivers are also available at <http://www.ibm.com/support/>.

- **IBM Drive Letter Access**

You can use this program to copy files to CD-R or CD-RW media.

- **IBM Product Registration**

You can use this program to register the computer with IBM. When you register the computer with IBM, information is entered into a database, which enables IBM to contact you in case of a recall or other problems. Some IBM locations offer extended privileges and services to registered users.

- **Sonic RecordNow Business Edition and DLA**

You can use this program to record data or audio to CD-R or CD-RW media or to create copies of existing CDs.

- **WinDVD or LinDVD**

This software comes on models with DVD read capability. You can use this program to play DVDs.

- **DVDCreator**

This software comes on models with DVD write capability. You can use this program to create DVDs.

- **Norton Internet Security**

You can use this program to detect and remove viruses from the computer.

- **Online Books**

You can use this program to access documentation that contains detailed information about the computer.

- **PC-Doctor**

This program contains diagnostic tools that you can use within the operating system. In addition to isolating hardware problems, these tools provide information about the computer operating environment and some software components. Support documentation is built into the help system.

- **Product Recovery Program**

You can use this program to recover the operating system and other software programs in the event of a system failure.

Important: The Product Recovery Program is on a hidden, hard disk drive partition. Do not delete or otherwise destroy this partition.

You must have Internet access to use some of these programs. For more information about connecting to the Internet, see the operating-system documentation that comes with the computer.

See “Using preinstalled software” on page 12 for additional information about the preinstalled software.

Important:

1. You can reinstall the device drivers and applications that come with the computer from the directories on the hard disk.
2. The device drivers and some programs are also available at <http://www.ibm.com/support/> and on the *Device Drivers* CD.

Software on CD

In addition to the IBM-preinstalled programs and device drivers, additional software is provided on the *Device Drivers* CD or other CDs. You decide which programs to install according to your needs.

Device drivers

Some of the preinstalled device drivers are on the *Device Drivers* CD that comes with the computer.

Software available on the World Wide Web

The following software is available from the IBM Web site:

- **IBM Director Agent**

You can use IBM Director Agent to view detailed information about the hardware and software, set up alerts, monitor a variety of system resources, and manage your asset security. IBM Director Agent streamlines and automates personal computer (PC) systems-management and support tasks, such as asset deployment and tracking.

- **Remote Deployment Manager**

Remote Deployment Manager (RDM) is a graphical, server-based system deployment program that enables mass unattended installations of operating systems, software images, device drivers, and BIOS code updates to remote systems. When used with the Wake on LAN feature, RDM can remotely turn on the computer so that the installation can be done while the computer is not being used.

See the product documentation for these tools to determine whether the operating system supports this software. To download any of the tools or to get information about them, complete the following steps:

1. Go to <http://www.ibm.com/support/> and select your country.
2. Click the **Products** tab at the top of the page.
3. Under **Servers**, click **Intel processor-based**.
4. From the topics on the left, click **Systems Management**.
5. Scroll down and click a product to get details about the product. To download a product, select **Systems Management Downloads** in the **Download** category.

Reliability, availability, and serviceability features

Three important computer design features are reliability, availability, and serviceability (RAS). The RAS features help to ensure the integrity of the data that is stored in the computer, the availability of the computer when you need it, and the ease with which you can diagnose and repair problems.

The computer has the following RAS features:

- 24 hours a day, 7 days a week¹ customer support
- Limited warranty: 3-year
- Advanced Configuration and Power Interface (ACPI)
- Automatic computer restart after a power failure
- Automatic error retry or recovery
- Boot-block recovery
- Built-in, menu-driven configuration and setup programs
- Built-in, menu-driven SCSI configuration programs (some models)
- Cooling fan with speed-sensing capability
- Error codes and messages
- Error correcting code (ECC) double-data-rate 2 (DDR2) synchronous dynamic random access memory (SDRAM) with serial presence detect (SPD)
- Hard disk drive partition-based diagnostic programs
- Integrated Ethernet controller
- Integrated IEEE 1394 (FireWire) support
- Integrated SCSI support using a mini-PCI adapter
- Monitoring support for temperatures, voltages, and fan speed
- Power supply error LED
- Power-on self-test (POST)
- Predictive Failure Analysis[®] (PFA) on hard disk drives
- Read-only memory (ROM) checksums
- Upgradeable basic input/output system (BIOS) and POST code
- Wake on LAN capability

1. Service availability will vary by country. Response time varies; may exclude holidays.

Chapter 2. Operating the computer

This chapter provides information about how to use the computer.

Controls and LEDs

This section identifies the controls, LEDs, and front connectors on the IntelliStation M Pro Type 6218 computer. See “Input/output connectors” on page 68 for an illustration of the connectors on the rear of the computer.

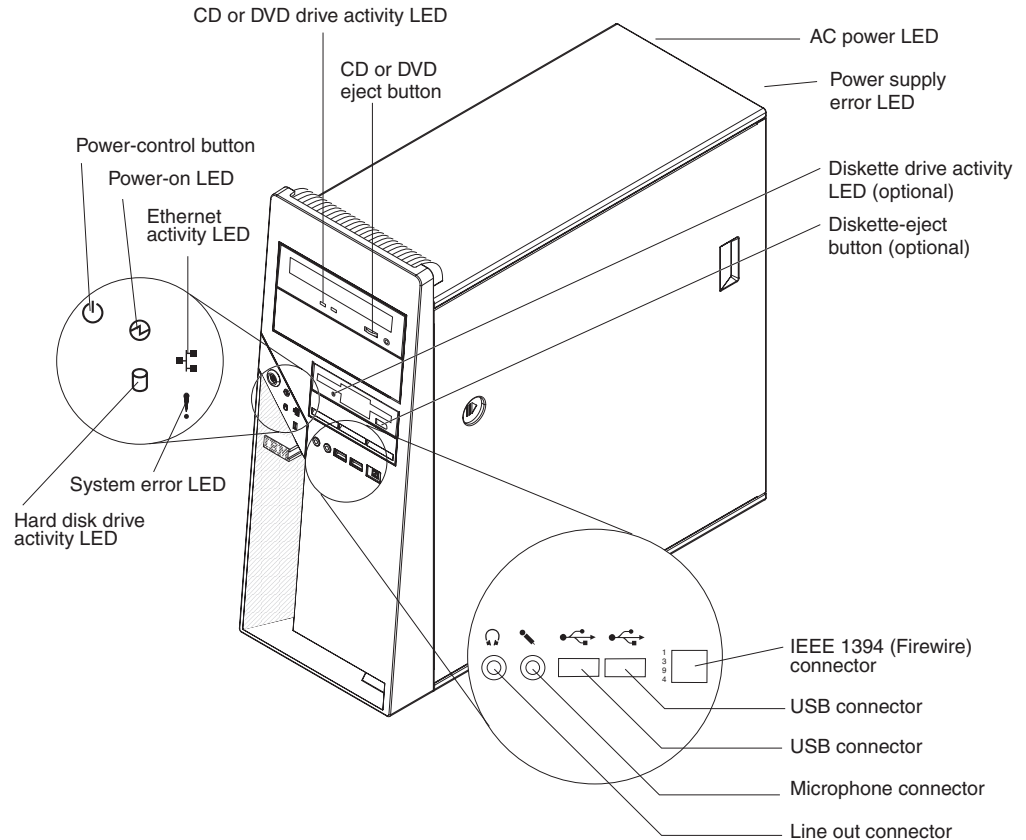

CD or DVD drive activity LED

When this LED is lit, it indicates that the CD or DVD drive is in use.

CD or DVD eject button

Press this button to insert or remove a CD or DVD.

AC power LED

When this green LED is lit, it indicates that the computer is connected to an ac power source. This LED is on the rear of the computer.

Power-supply error LED

When this amber LED is lit, it indicates that a power-supply error has occurred. This LED is on the rear of the computer.

Diskette drive activity LED

When this LED is lit, it indicates that the diskette drive is in use.

Diskette-eject button

Press this button to release a diskette from the diskette drive.

Note: The diskette drive is an optional feature on some models.

IEEE 1394 (FireWire) connectors

Use these connectors (four-pin on the front and six-pin on the rear) to connect FireWire devices, such as digital video cameras and external hard disk drives.

USB connectors

Use these connectors to connect USB devices to the computer, using redundant Plug and Play technology.

Microphone connector (pink)

Use this connector to connect a microphone to the computer when you want to record voices or other sounds on the hard disk. You can also use this connector (and a microphone) with speech-recognition software.

Line out connector (green)

Use this connector to send audio signals from the computer to external devices, such as speakers with built-in amplifiers, headphones, multimedia keyboards, or the audio line-in jack on a stereo system.

System-error LED

When this LED is lit, it indicates that a system error has occurred. An LED on the system board might also be lit to help isolate the error. If the system board LED is not lit, check the error log.

Hard disk drive activity LED

When this LED is lit, it indicates that the hard disk drive is in use.

Ethernet activity LED

When this LED is lit, it indicates that there is activity between the computer and the network. There are two of these LEDs, one on the front and one on the rear of the computer.

Power-on LED

When this LED is lit, it indicates that the computer is turned on.

Power-control button

Press this button to turn the computer on or off.

Ethernet link status LED

When this LED is flickering, it indicates that there is an active connection on the Ethernet connector. This LED is on the rear of the computer.

Turning on the computer

When the computer is connected to an ac power source but is not turned on, the operating system does not run, and all core logic is shut down; however, the computer can respond to remote requests to turn on the computer. The power-on LED flashes to indicate that the computer is connected to an ac power source but is not turned on.

Notes:

1. Turn on all external devices, such as the monitor, before turning on the computer.
2. The power-on LED on the front of the computer is lit when the computer is on and while it is being turned on.

Approximately 20 seconds after the computer is connected to ac power, the power-control button becomes active, and you can turn on the computer and start the operating system by pressing the power-control button. The computer can also be turned on in any of the following ways:

- If a power failure occurs while the computer is turned on, the computer will restart automatically when power is restored.
- When you connect the computer to power for the first time, the Wake on LAN feature can turn on the computer. If the computer was previously turned on, it must be turned off for the Wake on LAN feature to turn on the computer.

What you see and hear when you start the computer depends on the features that are installed and the settings in the Configuration/Setup Utility program.

If power-on self-test (POST) detects a problem, there might be a series of beeps or no beep, and a numeric error message might appear on the screen. Write down any beep series and error code numbers with descriptions, and then see the *Problem Determination and Service Guide* for an explanation of the error codes.

On a computer running a Windows operating system, the following messages might be displayed briefly during startup:

- Press F1 for Configuration/Setup Utility, Press F12 for Boot Menu
- Press CTRL+A for SCSISelect Utility, SAS/SATA Configuration Utility, or RAID Configuration Utility (some models)
- To start the Product Recovery Program, Press F11

On a computer running a Red Hat Linux operating system, the following messages might be displayed briefly during startup:

- Press F1 for Configuration/Setup Utility, Press F12 for Boot Menu
- Press CTRL+A for SCSISelect Utility, SAS/SATA Configuration Utility, or RAID Configuration Utility (some models)

To start the Product Recovery Program in Red Hat Linux, watch the screen until the operating system selection menu is displayed and select **IBM Preload Recovery & Diagnostics**.

To use these features, press the applicable function key or keys quickly. The messages appear for only a short time. For more information about these messages, see “Using the Configuration/Setup Utility program” on page 22 and “Using the SCSISelect Utility program (some models)” on page 32.

Use the Configuration/Setup Utility program to configure passwords, PCI adapters, and other options.

The operating system and application programs start from the hard disk. If the computer is attached to a network, the computer will begin attaching to any LANs and remote applications to which you have access. A network administrator can also start the computer remotely to download programs or gather information about computer performance. For more information, see “Wake on LAN” on page 18.

Using preinstalled software

This section contains information to assist you in setting up the preinstalled operating system and describes how to use the programs that come with the computer.

Running the operating-system setup program

The setup program runs automatically when you start the computer for the first time. The program will prompt you to make choices or type information. If you need more detailed information than is provided in this *User's Guide*, see the operating-system documentation.

Important:

1. After turning on the computer for the first time, you must complete the operating-system setup procedure before turning off the computer; otherwise, unexpected results might occur.
2. The setup program might be slightly different from the one that is described in the operating-system documentation. Some choices do not appear because they are preset.
3. During the setup procedure, you must indicate that you accept the license agreement.
4. For Windows operating systems, the registration information is already displayed in the registration field. If the product ID number is not already displayed, you must type it. The product ID is on a label that is attached to the computer.

You will need the following information to complete the setup program:

- The documentation that comes with the computer.
- Network information from the network administrator, if the computer is being connected to a network.
- The printer model and port, if a printer is attached directly to the computer.

After the setup procedure is completed and the computer restarts, the desktop opens. the computer is ready for use.

Installing other operating systems

The computer comes with Microsoft® Windows XP Professional or Red Hat Enterprise Linux Workstation preinstalled. To install another operating system, follow the instructions in the documentation that comes with the operating system.

If you are installing an operating system other than Microsoft Windows XP or Red Hat Linux Workstation, follow the instructions in the readme files on the *Device Drivers* CD to install the device drivers. You might also need additional software or device drivers.

Note: If you experience problems with the device drivers that are installed from the *Device Drivers* CD, you can obtain the latest device drivers at <http://www.ibm.com/support/>.

Before installing any operating system, be sure to obtain the latest updates. Contact the operating-system manufacturer or, if applicable, check the manufacturer's Web site to obtain the updates.

Additional information about operating systems is posted periodically at <http://www.ibm.com/support/>.

Viewing the license agreement

The IBM International License Agreement for Non-Warranted Programs is viewable from the Access IBM folder. Use of the computer signifies acceptance of this agreement.

To view the license agreement in Windows XP, complete the following steps:

1. From the Windows XP desktop, click **Start → All Programs → Access IBM**.
2. Click **IBM License Agreement**.

For Red Hat Linux, when you start the computer, the License Agreement window opens. To accept the terms of the agreement, click **I Agree**. You can also view the license agreement by clicking the **IBM License Agreement** icon on the desktop.

Registering the computer

Registering the computer helps IBM provide better service to you. When IBM receives the registration information, the information is placed into a central technical support database. If you need technical assistance, the technical-support representative will have information about the computer. In addition, comments about the computer are reviewed by a team dedicated to customer satisfaction and are taken into consideration in making improvements to IBM computers.

Use one of the following procedures to register the computer in Windows:

- From the Windows XP desktop, click **Start → All Programs → IBM Registration** and then follow the instructions. If you do not have access to the Internet, you can use the registration program that starts through the IBM Registration folder to print the registration information and provide IBM with a mailing address for future technical assistance.
- Register the computer at <http://www.ibm.com/pc/register/>.

For Red Hat Linux, click the **Register PC** icon on the desktop to register the computer on the World Wide Web.

Creating an emergency recovery-repair diskette in Windows

Note: To create and use a diskette, you must add a diskette drive to the computer. To enable a USB diskette drive to work, you must disable the legacy diskette drive function in the Configuration/Setup Utility program (click **Start Options → Disable Legacy Diskette A**).

At the earliest opportunity, create a recovery-repair diskette and an IBM Enhanced Diagnostics diskette, and store them in a safe place. In the unlikely event that the computer becomes unusable, you can use the recovery-repair diskette to access the Product Recovery program.

In Windows, you can create a recovery-repair diskette from the c:\ibmtools directory or from the Product Recovery program partition.

To create a recovery-repair diskette from the c:\ibmtools directory, complete the following steps:

1. Start the computer and operating system.

2. Use Windows Explorer to display the directory structure of the hard disk.
3. Open the c:\ibmtools folder.
4. Double-click **rrdisk.bat** and follow the instructions on the screen.

To create a recovery-repair diskette from the Product Recovery program on the hard disk, complete the following steps:

1. Shut down the operating system and turn off the computer.
2. Wait for at least 5 seconds, then press and hold the F11 key while you restart the computer. When a menu appears, release the F11 key.
3. Use one of the following procedures:
 - If a menu is displayed that gives you the opportunity to select an operating system, use the arrow keys to select the operating system that is currently installed, press Enter, and then continue with the next step.
 - If an operating-system menu is not displayed, continue with the next step.
4. From the Product Recovery main menu, use the arrow keys to select **System utilities**, and then press Enter.
5. Use the arrow keys to select **Create a Recovery Repair diskette**, and then press Enter.
6. Follow the instructions on the screen.

See “Creating an IBM Enhanced Diagnostics Diskette or CD in Windows” for information about how to create an IBM Enhanced Diagnostics diskette.

Creating an IBM Enhanced Diagnostics Diskette or CD in Windows

Note: To create and use a diskette or CD, you must have a diskette, CD-RW, or DVD/CD-RW combo drive installed in the computer. To enable a USB diskette drive to work, you must disable the legacy diskette drive function in the Configuration/Setup Utility program (click **Start Options** → **Disable Internal Floppy Support**).

The *IBM Enhanced Diagnostics* diskette is a self-starting diagnostics diskette that is used to test hardware components in the computer. You can create only an IBM Enhanced Diagnostics diskette from the Product Recovery program. You can create an IBM Enhanced Diagnostics diskette or CD from the World Wide Web.

To create an IBM Enhanced Diagnostics diskette from the Product Recovery program partition on the hard disk, complete the following steps:

1. Restart the computer and watch the monitor.
2. When the message To start the Product Recovery Program, Press F11 appears, quickly press F11.
3. Select **System utilities**.
4. Select **Create IBM Enhanced Diagnostics Diskette**.
5. Follow the instructions on the screen.

To create an IBM Enhanced Diagnostics diskette from the World Wide Web, complete the following steps:

1. Go to <http://www.ibm.com/>.
2. Click **Support & downloads**.
3. Click **Search technical support**.
4. In the **Enter keyword(s)** field, type `diagnostics 6218`, and click **Submit**.

5. From the "Search results" page, click the Enhanced Diagnostics item for the computer.
6. On the next page, click the executable file for the Enhanced Diagnostics code to download it (be sure to download the file to a hard disk directory and not to a diskette). You can click the text file to display the readme file.
7. At a command prompt, change to the directory where the file was downloaded.
8. Insert a blank, high-density diskette into the diskette drive.
9. Type `filename a:` where *filename* is the name of the file you downloaded and *a* is the letter for the diskette drive, and press Enter.

The downloaded file is self-extracting and is copied to the diskette. When the copy is completed, store the diskette in a safe place.

To download the latest CD image of the IBM Enhanced Diagnostics from the Web, and create a startable Enhanced Diagnostics CD, complete the following steps:

1. Go to <http://www.ibm.com/>.
2. Click **Support & downloads**.
3. Click **Search technical support**.
4. In the **Enter keyword(s)** field, type `diagnostics 6218`, and click **Submit**.
5. From the "Search results" page, click the Enhanced Diagnostics item for the computer.
6. On the next page, click the CD image file for the Enhanced Diagnostics code and download it using a writeable optional device (CD-RW or DVD/CD-RW combo drive).

For more information about using the IBM Enhanced Diagnostics program, see the *Problem Determination and Service Guide* on the IBM *IntelliStation Documentation* CD.

Using video features

The computer has a PCI Express x16 graphics adapter that renders 2D or 3D image quality and uses a standard video protocol for displaying text and graphic images on a monitor screen. The adapter supports a variety of video modes (combinations of resolution, refresh rate, and color that are defined by a video standard for displaying text or graphics).

Video device drivers

To use the full capabilities of the graphics adapter in the computer, some operating systems and application programs require custom video device drivers. These device drivers provide greater speed, higher resolution, more available colors, and flicker-free images.

Device drivers for the graphics adapter and a readme file with instructions for installing the device drivers are provided on the *Device Drivers* CD that comes with the computer and in the `c:\ibmtools\drivers` directory on the hard disk. Use the device-driver installation instructions if you have to reinstall the device drivers or if you need information about obtaining and installing updated device drivers. For more information about installing device drivers, see the *Problem Determination and Service Guide*.

Changing monitor settings

To get the best possible image on the screen and to reduce flicker, you might have to reset the resolution and refresh rate of the monitor. You can view and change monitor settings through the operating system by following the instructions in the readme files on the *Device Drivers* CD or in the c:\ibmtools\drivers\ directory on the hard disk. See the operating-system documentation for more information about monitor settings.

Attention: Before changing monitor settings, review the documentation that comes with the monitor. Using a resolution or refresh rate that the monitor does not support might cause the screen to become unreadable and could damage the monitor. The information that comes with the monitor usually includes resolution and screen refresh rates that the monitor supports. If you need additional information, contact the manufacturer of the monitor.

If you are using a cathode ray tube (CRT) monitor, set the monitor for the highest noninterlaced refresh rate that the monitor supports. If the monitor complies with the Video Electronics Standards Association (VESA) display data channel (DDC) standard, it is probably already set to the highest refresh rate the monitor and video controller can support. If you are not sure whether the monitor is DDC-compliant, see the documentation that comes with the monitor.

If you are using a flat-panel monitor, the refresh rate does not have to be set to the highest noninterlaced refresh rate that the monitor supports. Flat-panel monitors produce flicker-free images even when they are operating at a minimum 60 Hz noninterlaced rate.

If you have a dual-monitor video adapter, see the video adapter device-driver readme file and documentation for more information about enabling dual monitors.

Using audio features

The computer has an integrated audio controller that supports Sound Blaster applications. The computer also has a single internal speaker and three types of audio connectors. Using the audio controller, you can record and play back sound and music to enhance multimedia applications. Optionally, you can connect external speakers to the line-out connector to provide improved sound with multimedia applications.

The audio connectors in the computer are 3.5 mm (0.125-in.) mini-jacks. For the location of the audio connectors, see "Input/output connectors" on page 68.

Line in

This connector accepts audio signals into the computer sound system from external devices, such as the line output from a stereo, television, or a musical instrument. One line-in connector is on the rear of the computer.

Line out

This connector sends audio signals from the computer to external devices, such as speakers with built-in amplifiers, headphones, multimedia keyboards, or the audio line-in jack on a stereo system. Line-out connectors are on both the front and the rear of the computer.

Microphone

Use this connector to connect a microphone to the computer when you want to record voice or other sounds on the hard disk. With a microphone

attached to the computer, you can also use speech-recognition software. One microphone connector is on the front of the computer.

Using security features

To deter unauthorized use of the computer, you can use anti-intrusion features and other security features that are provided with the computer.

Anti-intrusion features

IBM anti-intrusion features help protect against the theft of computer components, such as the microprocessor, system memory modules, or hard disk drives.

You can set the chassis-intrusion detector switch inside the computer to alert the network administrator each time the computer cover is removed. For more information about setting the chassis-intrusion alert, see Chapter 3, “Configuring the computer,” on page 21.

Component protection

Each component in the computer has a serial number that you can register with a security company. You can register the components individually, or you can register the entire computer. By registering computer components, you can improve the chances of identifying the components if they are ever stolen and recovered. For more information about component registration, see <http://www.ibm.com/support/>.

Data protection

You can lose data from the hard disk for a variety of reasons. Security violations, viruses, or hard disk drive failures can all contribute to data loss. To help protect against the loss of valuable information, IBM has incorporated the following data-saving features in the computer:

- **SMART hard disk drive**

The computer comes with a self-monitoring and reporting technology (SMART) hard disk drive that is enabled to report potential hard disk failures. If an error is detected, a Desktop Management Interface (DMI) compliant warning message is sent to the monitor screen and, if the computer is part of a network, to an administrator console. When an error is detected, the data on the hard disk can be backed up and the drive replaced.

- **Virus protection**

The computer has built-in virus protection that can be enabled through the IBM Configuration/Setup Utility program. Norton AntiVirus for IBM is available on the hard disk.

Locking the keyboard

You can lock the keyboard so that others are unable to use it. If a user password is set using the Configuration/Setup Utility program, the keyboard is locked when you turn on the computer. You must type the password to unlock the keyboard. See “Using passwords” on page 24.

Some operating systems have a keyboard and mouse lock-up feature. See the documentation that comes with the operating system for more information.

Updating system programs

System programs are the basic layer of software that is built into the computer. They include the power-on self-test (POST), the basic input/output system (BIOS) code, and the Configuration/Setup Utility program.

System programs are stored in electrically erasable programmable read-only memory (EEPROM) on the system board. This is sometimes referred to as flash memory.

IBM occasionally makes changes and enhancements to the system programs. When updates are released, they are available as downloadable files on the World Wide Web (see Appendix A, “Getting help and technical assistance,” on page 75). You can update system programs by starting the computer using a flash update diskette, or if the computer is connected to a network, a network administrator can update the system program remotely. Instructions for using system program updates are included in a readme file that comes with the downloadable files.

Managing the computer

The computer comes with features that a network administrator or server can use to remotely manage and control the computer. This section describes some of these network-management tools. See the product documentation for these tools to determine whether the operating system supports this software. To get more detailed information about these tools or to download any of this software, complete the following steps:

1. Go to <http://www.ibm.com/support/>.
2. Under **Download**, click **Downloads & Drivers**.
3. From the **Brand** drop-down list, click **Systems Management**, and click **Continue**.
4. Scroll down and click a product to get more details about the product or to download the product.

The computer supports the following system management tools:

- **IBM Director Agent**

IBM Director Agent streamlines and automates personal computer (PC) systems-management and support tasks, such as asset deployment and tracking. These utilities are available for IBM computers at no additional charge, helping to reduce total cost of ownership of networked computers. IBM Director Agent is available at <http://www.ibm.com/support/>.

You can use IBM Director Agent to view detailed information about the computer hardware and software, set up alerts, monitor a variety of system resources, and manage your asset security.

- **Wake on LAN**

A network administrator can use the Wake on LAN feature to turn on the computer from a remote location. When the Wake on LAN feature is used with network-management software, many functions, such as data transfers, software updates, and POST or BIOS code updates can be performed on many computers simultaneously.

Note: The Wake on LAN feature works only if the computer was correctly shut down and turned off.

- **Remote Administration**

A network administrator can use the Remote Administration feature to remotely update the POST and BIOS code in the computer. Network-management software, such as Remote Deployment Manager, is required to take advantage of this feature.

- **Remote Deployment Manager**

Remote Deployment Manager is a graphical, server-based program that performs mass unattended installations of operating systems, software, device drivers, and BIOS updates to remote systems. Used with the Wake on LAN feature, Remote Deployment Manager can remotely turn on the computer so that installations can be done while the computer is not being used.

Shutting down the operating system

When you are ready to turn off the computer, use the shutdown procedure for the operating system to save data and prevent damage to the applications. See the operating-system documentation for more information.

If you are using the preinstalled Microsoft Windows XP operating system, to shut down the operating system and computer, complete the following steps:

1. Save and close all files with which you are working.
2. Close all open applications.
3. Click **Start**.
4. Click **Turn Off Computer**, and click **Turn Off** to confirm.

If you are using the preinstalled Red Hat Linux operating system, to shut down the operating system and computer, complete the following steps:

1. Save and close all files with which you are working.
2. Close all open applications.
3. Click **Red Hat Linux Main Menu Button** → **Logout** → **Shutdown**.
4. Click **OK** to confirm.

Turning off the computer

When you turn off the computer and leave it connected to ac power, the computer can respond to requests, such as a remote request to turn on the computer. To remove all power from the computer, you must disconnect it from the power source.

Some operating systems require an orderly shutdown before you turn off the computer. See the operating-system documentation for information about shutting down the operating system.

Statement 5:



CAUTION:

The power control button on the device and the power switch on the power supply do not turn off the electrical current supplied to the device. The device also might have more than one power cord. To remove all electrical current from the device, ensure that all power cords are disconnected from the power source.

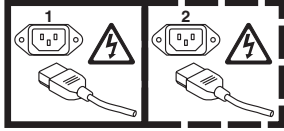

The computer can be turned off in any of the following ways:

- You can turn off the computer from the operating system. If this feature is supported by the operating system, it will turn off the computer after performing an orderly shutdown of the operating system.

To turn off the computer from the Microsoft Windows XP operating system, click **Start → Turn Off Computer**, and click **Turn Off**.

To turn off the computer from the Red Hat Linux operating system, click **Red Hat Linux Main Menu Button → Logout → Shutdown**, and click **Yes**.

- You can press the power-control button on the front of the computer to start an orderly shutdown of the operating system and turn off the computer, if the operating system supports this feature.

Note: After turning off the computer, wait at least 5 seconds before you press the power-control button to turn on the computer again.

- You can press and hold the power-control button for more than 4 seconds to cause an immediate shutdown of the computer. You can use this feature to turn off the computer if the operating system stops functioning.

Chapter 3. Configuring the computer

The following configuration programs are available to configure the computer:

- **Configuration/Setup Utility program**

The Configuration/Setup Utility program is part of the basic input/output system (BIOS) code in the computer. You can use this program to configure serial port assignments, change interrupt request (IRQ) settings, change the device startup sequence, set the date and time, set passwords, and set the chassis-intrusion detector. For information about using this utility program, see “Using the Configuration/Setup Utility program” on page 22.

- **Boot Menu program**

The Boot Menu program is part of the BIOS code in the computer. Use it to temporarily assign a device to be first in the startup sequence, overriding the startup sequence that is set in the Configuration/Setup Utility program. For information about using this utility program, see “Using the Boot Menu program” on page 25.

- **Broadcom NetXtreme Gigabit Ethernet Boot Agent**

The Broadcom NetXtreme Gigabit Ethernet Boot Agent is part of the BIOS code in the computer. You can use it to configure the network as a startable device, and you can customize where the network startup option appears in the startup sequence. You enable and disable the Broadcom NetXtreme Gigabit Ethernet Boot Agent from the Configuration/Setup Utility program. For information, see “Enabling the Broadcom NetXtreme Gigabit Ethernet Boot Agent” on page 26.

- **Adaptec HostRAID configuration programs**

- **Adaptec RAID Configuration Utility programs (for Serial ATA RAID)**

Use the Array Configuration Utility within the Adaptec RAID Configuration Utility programs, to configure the integrated Serial ATA (SATA) controller with integrated RAID and the devices attached to it. The SATA HostRAID program is part of the BIOS code in the computer. Use this utility program to define the HostRAID configuration, format or verify SATA hard drives. For additional information about using these utility programs, see “Using the Adaptec RAID Configuration Utility program (for SATA RAID)” on page 27.

- **SCSISelect Utility program (for SCSI RAID)**

Use the SCSI HostRAID feature of the SCSISelect Utility program to configure the integrated SCSI controller with integrated RAID, and the devices that are attached to it. For more information about using this utility program, see “Using the SCSISelect Utility program (for SCSI RAID)” on page 28.

- **SAS/SATA Configuration Utility program (for Serial Attached SCSI RAID)**

With the SAS/SATA Utility Configuration program, you can configure the devices that are connected to the SAS mini-PCI adapter. Use this program to change default values, resolve configuration conflicts, and perform a low-level format on a SAS hard disk drive. For additional information about using these utility programs, see “Using the SAS/SATA Configuration Utility (for Serial Attached SCSI RAID)” on page 29.

- **ServeRAID Manager**

ServeRAID™ Manager is available as a stand-alone program and as an IBM Director extension. If a ServeRAID controller is installed in the computer, use ServeRAID Manager to define and configure the disk-array subsystem before you install the operating system. For information about using this program, see “Using ServeRAID Manager” on page 30.

- **Broadcom NetXtreme Gigabit Ethernet controller configuration**

To configure the integrated Gigabit Ethernet controller, see “Configuring the Broadcom NetXtreme Gigabit Ethernet controller” on page 32.

- **SCSISelect Utility program (some models)**

If the computer comes with a SCSI adapter, you can use the SCSISelect Utility program to configure devices that are attached to the SCSI adapter. Use this program to change default values, resolve configuration conflicts, and perform a low-level format on a SCSI hard disk drive. For information about using this utility program, see “Using the SCSISelect Utility program (some models)” on page 32.

Using the Configuration/Setup Utility program

This section provides instructions for starting the Configuration/Setup Utility program and descriptions of the menu choices that are available.

Starting the Configuration/Setup Utility program

To start the Configuration/Setup Utility program, complete the following steps:

1. Turn on the computer and watch the monitor screen. If the computer is already on when you start this procedure, you must shut down the operating system, turn off the computer, wait a few seconds until all in-use LEDs are turned off, and restart the computer.
2. When the message Press F1 for Configuration/Setup, Press F12 for Boot Menu appears on the screen during startup, press F1. (This prompt appears on the screen for only a few seconds. You must press F1 quickly.) If you have set both a user password and an administrator password, you must type the administrator password to access the full Configuration/Setup Utility menu.
3. Follow the instructions on the screen.

Configuration/Setup Utility menu choices

The following choices are on the Configuration/Setup Utility main menu. Depending on the version of the BIOS code in the computer, some menu choices might differ slightly from these descriptions.

Note: When you use the computer for the first time, you might want to use the Configuration/Setup Utility menu choice **Load Default Settings** to reset the Configuration/Setup Utility menu choices to the factory default settings, in case they were changed before you received the computer. Otherwise, some choices might not appear in the list of menu choices.

- **System Summary**

Select this choice to view configuration information, including the amount of installed memory. When you make configuration changes through other options in the Configuration/Setup Utility program, the changes are reflected in the system summary; you cannot change settings directly in the system summary.

This choice is on the full and limited Configuration/Setup Utility menu.

- **Processor summary**

Select this choice to view the processor information, including the type, speed, and cache size of the microprocessor.

- **System Information**

Select this choice to view information about the computer. When you make changes through other options in the Configuration/Setup Utility program, some of those changes are reflected in the system information; you cannot change settings directly in the system information.

This choice is on the full Configuration/Setup Utility menu only.

- **Devices and I/O Ports**

Select this choice to view or change the assignments for devices and input/output (I/O) ports.

Select this choice to enable or disable the mini-PCI SCSI and Ethernet controllers, and standard connectors (such as serial and parallel). **Enable** is the default setting for all controllers. If you disable a device, it cannot be configured, and the operating system will not be able to detect it (this is equivalent to disconnecting the device). If you disable the mini-PCI SCSI controller and no SCSI adapter is installed, the computer will have no SCSI capability. If you disable the integrated Ethernet controller and no Ethernet adapter is installed, the computer will have no Ethernet capability.

This choice is on the full Configuration/Setup Utility menu only.

- **Remote Console Redirection**

Select this choice to enable and configure serial remote video and keyboard redirection.

- **System MAC Address**

Select this choice to view the MAC addresses for network devices that are installed in the computer.

Note: This choice appears only if at least one Preboot eXecution Environment (PXE) option, read only memory (ROM) starts during POST.

- **Video**

Select this choice to view the video information.

- **Date and Time**

Select this choice to set the date and time in the computer, in 24-hour format (*hour:minute:second*).

This choice is on the Configuration/Setup Utility menu only.

- **System Security**

Select this choice to set password settings. See “Using passwords” on page 24 for more information about passwords. You can also enable the chassis-intrusion detector to alert you each time the computer cover is removed.

- **Set Administrator Password**

This choice is on the Configuration/Setup Utility menu.

Select this choice to set or change an administrator password. An administrator password is intended to be used by a system administrator; it limits access to the full Configuration/Setup Utility menu. If an administrator password is set, the full Configuration/Setup Utility menu is available only if you type the administrator password at the password prompt.

- **Set Power-on Password**

Select this choice to set or change a power-on password.

- **Start Options**

Select this choice to view or change the startup options. Changes in the startup options take effect when you start the computer.

You can set keyboard operating characteristics, such as the keyboard speed, or specify whether the computer starts with the keyboard number lock on or off.

You can enable a virus-detecting test that checks for changes in the boot record when the computer starts.

- **Startup Sequence Options**

Select this choice to view the **Startup Sequence** menu. The startup sequence specifies the order in which the computer checks devices to find a boot record. The computer starts from the first boot record that it finds.

- **Advanced Setup**

Select this choice to change values for advanced hardware features, such as CPU options and PCI configuration.

Important: The computer might malfunction if these options are incorrectly configured. Follow the instructions on the screen carefully.

This choice is on the full Configuration/Setup Utility menu only.

- **CPU Options**

Select this choice to enable or disable the microprocessor cache and Hyper-Threading Technology. The default status for Hyper-Threading Technology is **Disabled** (some models).

- **PCI Bus Control**

Select this choice to view the system resources that are used by the installed PCI or PCI-Express devices.

- **Hardware Monitor**

Select this choice to display the computer temperature, voltage status, and fan speeds.

- **Error Log**

Select this choice to view or clear error logs.

- **POST Error Log**

Select this choice to view the three most recent error codes and messages that were generated during POST.

- **System Event/Error Log**

Select this choice to view the system event and error messages that the system generated during POST and runtime. Select **Clear event/error logs** to clear the event and error log.

- **Save Settings**

Select this choice to save the changes you have made in the settings.

- **Restore Settings**

Select this choice to cancel the changes you have made in the settings and restore the previous settings.

- **Load Default Settings**

Select this choice to cancel the changes you have made in the settings and restore the factory settings.

- **Exit Setup**

Select this choice to exit from the Configuration/Setup Utility program. If you have not saved the changes you have made in the settings, you are asked whether you want to save the changes or exit without saving them.

Using passwords

You can use any combination of up to seven characters (A–Z, a–z, and 0–9) for the power-on (user) password or the administrator password.

If you set a power-on password and an administrator password and enable the Allow for unattended boot with password, you can type either password at the password prompt that appears as you start the computer. However, if you want to change the settings in the Configuration/Setup Utility program, you must type the

administrator password to access the full Configuration/Setup Utility menu. If you type the power-on password, you have access to only the limited Configuration/Setup Utility menu.

Keep a record of the password in a secure place. If you forget the power-on or administrator password, you can regain access to the computer through one of the following methods:

- If you have forgotten the power-on password and an administrator password is set, type the administrator password at the power-on prompt. Start the Configuration/Setup Utility program and change the power-on password.
- Remove the battery and then install the battery.

Using the Boot Menu program

The Boot Menu program is a built-in, menu-driven configuration utility program that you can use to temporarily redefine the first startup device without changing settings in the Configuration/Setup Utility program.

To use the Boot Menu program, complete the following steps:

1. Turn off the computer.
2. Restart the computer.
3. Press F12.
4. Select the startup device.

The next time the computer is started, it returns to the startup sequence that is set in the Configuration/Setup Utility program.

Enabling the Broadcom NetXtreme Gigabit Ethernet Boot Agent

The Broadcom NetXtreme Gigabit Ethernet Boot Agent is part of the BIOS code in the computer. You can use it to configure the network as a startable device, and you can customize where the network startup option appears in the startup sequence. You enable and disable the Broadcom NetXtreme Gigabit Ethernet Boot Agent from the Configuration/Setup Utility program.

To enable the Broadcom NetXtreme Gigabit Ethernet boot agent, complete the following steps:

1. From the Configuration/Setup Utility main menu, select **Devices and I/O Ports** and press Enter.
2. Select **Planar Ethernet** and use the Right Arrow (→) key to set it to **Enabled**.
3. Set the Network-Planar device as the first startup device under the **Startup Option → Startup Sequence Options** menu choice in the Configuration/Setup Utility program.
4. Select **Save Settings** and press Enter.

Using the Adaptec HostRAID configuration programs

Notes:

1. HostRAID is not supported on SCO 6.0 and UnixWare 7.14 operating systems.
2. For SAS and Ultra320 SCSI models, SATA HostRAID must be set to disabled.

Use the Adaptec RAID Configuration Utility programs and SCSISelect Utility (also referred as IBM ServeRAID-8e), to add RAID level-0 and level-1 functionality to the integrated SATA controller and the integrated SCSI controller. RAID level-0 is striping where the drives are seen as a single volume, and increases performances. RAID level-1 is mirroring where the contents of one drive are copied to the other drive to increase hard drive availability. Be sure to use these programs as described in this document. Use these programs to:

- Configure a redundant array of independent disks (RAID) array.
- View or change the RAID configuration and associated devices.

Consider the following information when using the Adaptec RAID Configuration Utility program and SCSISelect Utility program to configure and manage arrays:

- The integrated SCSI controller with integrated SCSI RAID (in SCSI models) and the integrated SATA (in SATA models) with integrated SATA RAID supports RAID levels 0 and 1, with the option of having a hot-spare drive. Installing an optional ServeRAID controller provides additional RAID levels.
- Hard disk drive capacities affect how you create arrays. Drives in an array can have different capacities, but the RAID controller treats them as if they all have the capacity of the smallest hard disk drive.
- To help ensure signal quality, do not mix drives with different speeds and data rates.
- To update the firmware and BIOS code for an optional Serveraid adapter, you must use the IBM *ServeRAID Support* CD that comes with the ServeRAID option.
- If you install a different type of RAID adapter in the computer, use the configuration method described in the instructions that come with that adapter to view or change SCSI settings for attached devices.

Using the Adaptec RAID Configuration Utility program (for SATA RAID)

Use the Array Configuration Utility within the Adaptec RAID Configuration Utility program to add RAID level-0 and level-1 functionality to the integrated SATA controller. The Array Configuration Utility is part of the BIOS code in the computer. For additional information about using the Adaptec RAID Configuration Utility programs, see the documentation on the *IBM ServeRAID-8e (Adaptec HostRAID) Support CD*. If this CD does not come with the computer, you can download it from <http://www.ibm.com/support/>.

The integrated SATA RAID feature (SATA HostRAID) comes disabled by default. You must enable it and install the device drivers before you can use it. The SATA RAID feature configuration utilities, device drivers, and information are available on the *IBM ServeRAID-8e (Adaptec HostRAID) Support CD*.

Enabling the Serial ATA HostRAID feature

To enable the SATA RAID feature, complete the following steps:

1. Turn on the computer.
2. When the prompt **Press F1 for Configuration/Setup** appears, press F1. If you have set a supervisor password, you are prompted to type the password.
3. Select **Devices and I/O Ports**.
4. Scroll down and select **SATA RAID Enable**.
5. Select **Enabled**.
6. Press Esc, and select **Yes** to save the changes.

Using the Serial ATA HostRAID feature

The instructions in this section are for using the Array Configuration Utility program to access and perform an initial RAID level-1 configuration. If you install a RAID adapter in the computer, use the configuration method described in the instructions that come with the adapter to view or change settings for the attached devices.

See the documentation on the *IBM ServeRAID-8e (Adaptec HostRAID) Support CD* for additional information about using the Array Configuration Utility program to create, configure, and manage arrays. If the CD did not come with the computer, you can download the *IBM ServeRAID-8e (Adaptec HostRAID) Support CD* from <http://www.ibm.com/support/>.

Configuring the controller: To use the Array Configuration Utility program to configure a RAID level-1 for the computer, complete the following steps:

1. Turn on the computer.
2. When the prompt **<CTRL><A>** for Adaptec RAID Configuration Utility appears, Press Ctrl+A.
3. Select **Array Configuration Utility (ACU)**.
4. Select **Create Array**.
5. From the list of ready drives, select the two drives that you want to group into the array.
6. When asked to select the RAID level, select **RAID-1**.
7. (Optional) Type an identifier for the array.
8. When asked for the array build method, select **Quick Int**.
9. Follow the instructions on the screen to complete the configuration, and select **Done** to exit.
10. Restart the computer.

Viewing the configuration: To view information about the Serial ATA controller, complete the following steps:

1. Start the Array Configuration Utility.
2. From the Array Configuration Utility screen, select **Manage Arrays**.
3. Select an array and press Enter.
4. Press Esc to exit the program.

Using the SCSISelect Utility program (for SCSI RAID)

Use the SCSISelect Utility program to add RAID level-0 and level-1 functionality to the integrated SCSI controller. This utility is part of the BIOS code in the computer.

The integrated SCSI RAID feature (SCSI HostRAID) comes disabled by default. You must enable it and install the device drivers before you can use it. The SCSI RAID configuration utilities, device drivers, and information are available on the IBM *ServeRAID-8e (Adaptec HostRAID) Support CD*. If this CD does not come with the computer, you can download it from <http://www.ibm.com/support/>.

Enabling the SCSI HostRAID feature

To enable the SCSI RAID feature, complete the following steps:

1. Turn on the computer.
2. When the prompt Press <CTRL><A> for SCSISelect Utility appears, press Ctrl+A. If you have set a supervisor password, you are prompted to type the password.
3. Use the arrow keys to select the channel for which you want to change settings, and press Enter.
4. Select **Configure/View SCSI Controller Setting**, and select **HostRAID**.
5. Select **Enabled**.
6. Press Esc, and select **Yes** to save the changes.

Using the SCSI HostRAID feature

The instructions in this section describe how to access the SCSI RAID feature from the SCSISelect Utility program and perform an initial RAID level-1 configuration. If you install a RAID adapter in the computer, use the configuration method described in the instructions that come with that adapter to view or change SCSI settings for attached devices.

See the documentation on the IBM *ServeRAID-8e (Adaptec HostRAID) Support CD* for additional information about how to use the SCSI HostRAID feature.

Configuring the controller: To use the SCSI HostRAID feature to configure a RAID level-1 array, complete the following steps:

1. From the SCSISelect main menu, select **Configure/View HostRAID Settings**.
2. From the list of ready drives, type C to create an array.
3. When asked to select the RAID type, select **RAID-1**.
4. From the list of ready drives, select the two drives that you want to group into the array.
5. Select **Create new RAID-1**.
6. Type an identifier for the array.
7. Select **Yes** to create the array.
8. Press Esc to exit the utility.
9. Restart the computer.

Viewing the configuration: You can use the SCSISelect Utility program to review information about the integrated SCSI controller. From the list of available arrays, select an array and press Enter. Press Esc to exit the utility.

Using the SAS/SATA Configuration Utility (for Serial Attached SCSI RAID)

Use the SAS/SATA Configuration Utility within the Adaptec RAID Configuration Utility program to add RAID level-0 and level-1 functionality to the SAS controller. The SAS/SATA Configuration Utility is part of the BIOS code in the computer. For additional information about using the Adaptec RAID Configuration Utility programs, see the documentation on the IBM *ServeRAID-8e (Adaptec HostRAID) Support CD*. If this CD does not come with the computer, you can download it from <http://www.ibm.com/support/>.

The SAS HostRAID feature comes disabled by default. You must enable it and install the device drivers before you can use it. The SAS HostRAID feature configuration utilities, device drivers, and information are available on the IBM *ServeRAID-8e (Adaptec HostRAID) Support CD*.

Enabling the SAS HostRAID feature

To enable the SAS RAID feature, complete the following steps:

1. Turn on the computer and watch the monitor screen.
2. When the message Press <CTRL><A> for SAS/SATA Configuration Utility appears, press Ctrl+A.
3. Select **SerialSelect Utility**.
4. Select **Controller Configuration**.
5. Select **RAID support**.
6. Select **Enabled**.

Using the SAS HostRAID feature

The instructions in this section are for using the Array Configuration Utility program to access and perform an initial RAID level-1 configuration. If you install a RAID adapter in the computer, use the configuration method described in the instructions that come with the adapter to view or change settings for the attached devices.

See the documentation on the IBM *ServeRAID-8e (Adaptec HostRAID) Support CD*, for additional information about using the Array Configuration Utility program to create, configure, and manage arrays. If the CD did not come with the computer, you can download the IBM *ServeRAID-8e (Adaptec HostRAID) Support CD* from <http://www.ibm.com/support/>.

Configuring the controller: To use the Array Configuration Utility program to configure a RAID level-1 array, complete the following steps:

1. Turn on the computer and watch the monitor screen.
2. When the message Press <CTRL><A> for SAS/SATA Configuration Utility appears, press Ctrl+A.
3. Select **Array Configuration Utility (ACU)**.
4. Select **Create Array**.
5. From the list of ready drives, select the two drives that you want to group into the array.
6. When asked to select the RAID level, select **RAID-1**.
7. (Optional) Type an identifier for the array.

8. When asked for the array build method, select **Quick Int.**
9. Follow the instructions on the screen to complete the configuration, and select **Done** to exit.
10. Restart the computer.

Viewing the configuration: To view information about the SAS controller, complete the following steps:

1. Start the SAS/SATA Configuration Utility.
2. From the SAS/SATA Configuration Utility window, select **Manage Arrays**.
3. Select an array and press Enter.
4. Press Esc to exit the program.

Using ServeRAID Manager

Note: RAID is not supported on SCO 6.0 and UnixWare 7.14 operating systems.

Use the ServeRAID Manager program to:

- Configure arrays
- View the RAID configuration and associated devices
- Monitor operation of RAID controllers

To perform some tasks, you can run ServeRAID Manager as an installed program. To configure the SCSI controller and perform an initial RAID configuration on the computer, you must run ServeRAID Manager in a Startable-CD mode, as explained in the following section. If you install a RAID adapter in the computer, use the configuration method described in the instructions that come with the adapter to view or change SCSI settings for attached devices.

See the ServeRAID documentation in the **IBM ServeRAID Support** CD, or additional information about RAID technology and instructions for using ServeRAID Manager to configure the SCSI controller. Additional information about ServeRAID Manager is also available from the **Help** menu. For information about a specific object in the ServeRAID Manager tree, select the object and click **Actions → Hints and tips**.

Configuring the controller

By running ServeRAID Manager in Startable CD mode, you can configure the controller before you install the operating system. The information in this section assumes that you are running ServeRAID Manager in Startable CD mode.

To run the ServeRAID Manager program in Startable-CD mode, turn on the computer; then, insert the *IBM ServeRAID Support* CD into the CD-ROM drive. If the ServeRAID Manager program detects an unconfigured controller and ready drives, the program automatically starts the Configuration wizard.

In the Configuration wizard, you can select express configuration or custom configuration. Express configuration automatically configures the controller by grouping the first two physical drives in the ServeRAID Manager tree into an array and creating a RAID level-1 logical drive. If you select custom configuration, you can select the two physical drives that you want to group into an array and create a hot-spare drive.

Using express configuration

To use the express configuration, complete the following steps:

1. In the ServeRAID Manager tree, click the controller that you want to configure.
2. From the toolbar, click **Create**.
3. Click **Express configuration**.
4. Click **Next**. The “Configuration summary” window opens.
5. Review the information that is displayed in the “Configuration summary” window. To change the configuration, click **Modify arrays** or **Modify logical drives**.

Note: Some operating systems have size limitations for logical drives. Before you save the configuration, verify that the size of the logical drive is appropriate for the operating system.

6. Click **Apply**. Click **Yes** when asked if you want to apply the new configuration. The configuration is saved in the controller and in the physical drives.
7. Exit from the ServeRAID Manager program and remove the CD from the CD-ROM drive.
8. Restart the computer.

Using the custom configuration

To use the custom configuration, complete the following steps:

1. In the ServeRAID Manager tree, click the controller that you want to configure.
2. From the toolbar, click **Create**.
3. Click **Custom configuration**.
4. Click **Next**. The “Create arrays” window opens.
5. Click the applicable tab in the right pane, and from the list of ready drives, select the two drives you want to move to the array.
6. Click the icon to add the drives to the array.
7. If you want to configure a hot-spare, complete the following steps:
 - a. Click the **Spares** tab.
 - b. Select the physical drive you want to designate as the hot-spare drive, and click the icon to add the drive.
8. Click **Next**. The “Configuration summary” window opens.
9. Review the information that is displayed in the “Configuration summary” window. To change the configuration, click **Back**.
10. Click **Apply**. Click **Yes** when asked if you want to apply the new configuration. The configuration is saved in the controller and in the physical drives.
11. Exit from the ServeRAID Manager program, and remove the CD from the CD-ROM drive.
12. Restart the computer.

Viewing the configuration

You can use ServeRAID Manager to view information about RAID controllers and the RAID subsystem, (such as arrays, logical drives, hot-spare drives, and physical drives). When you click an object in the ServeRAID Manager tree, information about that object appears in the right pane. To display a list of available actions for an object, click the object and click **Actions**. To display available actions for an item, click the item in the ServeRAID Manager tree and click **Actions**.

Configuring the Broadcom NetXtreme Gigabit Ethernet controller

The Ethernet controller is integrated on the system board. It provides an interface for connecting to a 10-Mbps, 100-Mbps, or 1-Gbps network and provides full duplex (FDX) capability, which enables simultaneous transmission and reception of data on the network. If the Ethernet port in the computer supports auto-negotiation, the controller detects the data-transfer rate (10BASE-T, 100BASE-TX, or 1000BASE-T) and duplex mode (full-duplex or half-duplex) of the network and automatically operates at that rate and mode.

You do not have to set any jumpers or configure the controller. However, you must install a device driver to enable the operating system to address the controller. For device drivers and information about configuring the Gigabit Ethernet controller, see <http://www.ibm.com/support/>.

Using the SCSISelect Utility program (some models)

Use the SCSISelect Utility program to configure SCSI devices.

Starting the SCSISelect Utility program

To start the SCSISelect Utility program, complete the following steps:

1. Turn on the computer.
2. When the <<< Press <CTRL><A> for SCSISelect Utility! >>> prompt appears, press Ctrl+A. If you have set an administrator password, you are prompted to type the password.
3. Use the arrow keys to select a choice for which you want to change settings, and press Enter.
4. When the prompt Would you like to configure the SCSI controller or run the SCSI disk utility? appears, make the selection, and press Enter.
5. Use the arrow keys to select a choice from the menu, and press Enter.
6. Follow the instructions on the screen to change the settings of the selected items, and press Enter.

SCSISelect menu choices

The following choices are on the SCSISelect Utility menu:

- **Configure/View SCSI Controller Settings**

Select this choice to view or change SCSI controller settings. To reset the SCSI controller to its default values, press F6, and follow the instructions that appear on the screen.

You can view or change the following controller settings:

 - **SCSI Controller ID**

Select this choice to view the SCSI controller ID, which is typically 7.
 - **SCSI Controller Termination**

This choice is set to **Enabled** and cannot be changed.
 - **Boot Device Configuration**

Select this choice to configure bootable-device parameters. You must know the SCSI ID of the device that you want to configure.
 - **SCSI Device Configuration**

Select this choice to configure SCSI device parameters. You must know the SCSI ID of the device that you want to configure.

The sync transfer rate is the transfer rate for Ultra SCSI devices. For Ultra3 SCSI LVD devices, the maximum rate is 160 MBps; for Ultra2 SCSI LVD devices, 80 MBps; for Fast SCSI devices, 20 MBps; and for Ultra 320 devices, 320 MBps.

- **Advanced Configuration**

Select this choice to view or change the settings for advanced configuration options.

- **SCSI Disk Utilities**

Select this choice to view the SCSI IDs assignments or to format a SCSI device. Select a device from the list and read the instructions on the screen carefully before making a selection.

If you press Ctrl+A before a selected drive is ready, an Unexpected SCSI Command Failure screen might appear. Restart the computer and watch the SCSISelect messages as each drive spins up. When the selected drive is ready, press Ctrl+A.

Chapter 4. Installing options

This section provides instructions for installing and replacing hardware options in the computer. For a list of supported options for the computer, go to <http://www.ibm.com/intellistation/>; then, select your country and navigate to the list of options for the computer.

Installation guidelines

Before you install options, read the following information:

- Read the safety information on page vii, and the guidelines in “Handling static-sensitive devices” on page 36. This information will help you work safely.
- Observe good housekeeping rules in the area where you are working. Place removed covers and other parts in a safe place.
- Do not attempt to lift an object that you think is too heavy for you. If you have to lift a heavy object, observe the following precautions:
 - Make sure that you can stand safely without slipping
 - Distribute the weight of the object equally between your feet.
 - Use a slow lifting force. Never move suddenly or twist when you lift a heavy object.
 - To avoid straining the muscles in your back, lift by standing or pushing up with your leg muscles.
- Make sure that you have an adequate number of properly grounded electrical outlets for the computer, monitor, and other devices.
- Back up all important data before you make changes to disk drives.
- Have a small flat-blade screwdriver available.
- When you need to access the inside of the computer to install options, you might find it easier to lay the computer on its side.
- Blue on a component indicates touch points, where you can grip the component to remove it from or install it in the computer, open or close a latch, and so on.
- When you are finished working on the computer, reinstall all safety shields, guards, labels, and ground wires.

System reliability considerations

To help ensure proper system cooling and system reliability, make sure that:

- Each of the drive bays has a drive or a filler panel and electromagnetic compatibility (EMC) shield installed in it.
- There is adequate space around the computer to allow the computer cooling system to work properly. Leave approximately 50 mm (2 in.) of open space around the front and rear of the computer. Do not place objects in front of the fans. For proper cooling and airflow, replace the computer cover before turning on the computer. Operating the computer for extended periods of time (more than 30 minutes) with the computer cover removed might damage computer components.
- You have followed the cabling instructions that come with optional adapters.
- You have replaced a failed fan as soon as possible.

Handling static-sensitive devices

Attention: Static electricity can damage the computer and other electronic devices. To avoid damage, keep static-sensitive devices in their static-protective packages until you are ready to install them.

Notes:

1. If you are instructed to return a device or component, follow all packaging instructions. Use any packaging materials for shipping that are supplied to you.
2. Use product-specific electrostatic-discharge procedures when they exceed the requirements that are specified in this document.
3. Make sure that the electrostatic-discharge-protective devices you use have been certified (ISO-9000) as fully effective.

To reduce the possibility of damage from electrostatic discharge, observe the following precautions:

- Limit your movement. Movement can cause static electricity to build up around you.
- The use of a grounding system is recommended. For example, wear an electrostatic discharge wrist strap, if one is available.
- Handle the device carefully, holding it by its edges or its frame.
- Do not touch solder joints, pins, or exposed circuitry.
- Do not leave the device where others can handle and damage it.
- While the device is still in its static-protective package, touch it to an unpainted metal part of the computer for at least 2 seconds. This drains static electricity from the package and from your body.
- Remove the device from its package and install it directly into the computer without setting down the device. If it is necessary to set down the device, put it back into its static-protective package. Do not place the device on the computer cover or on a metal surface.
- Take additional care when handling devices during cold weather. Heating reduces indoor humidity and increases static electricity.

This section provides instructions for installing and replacing hardware options in the computer.

Major components of the computer

The following illustration shows the major components in the M Pro Type 6218 computer.

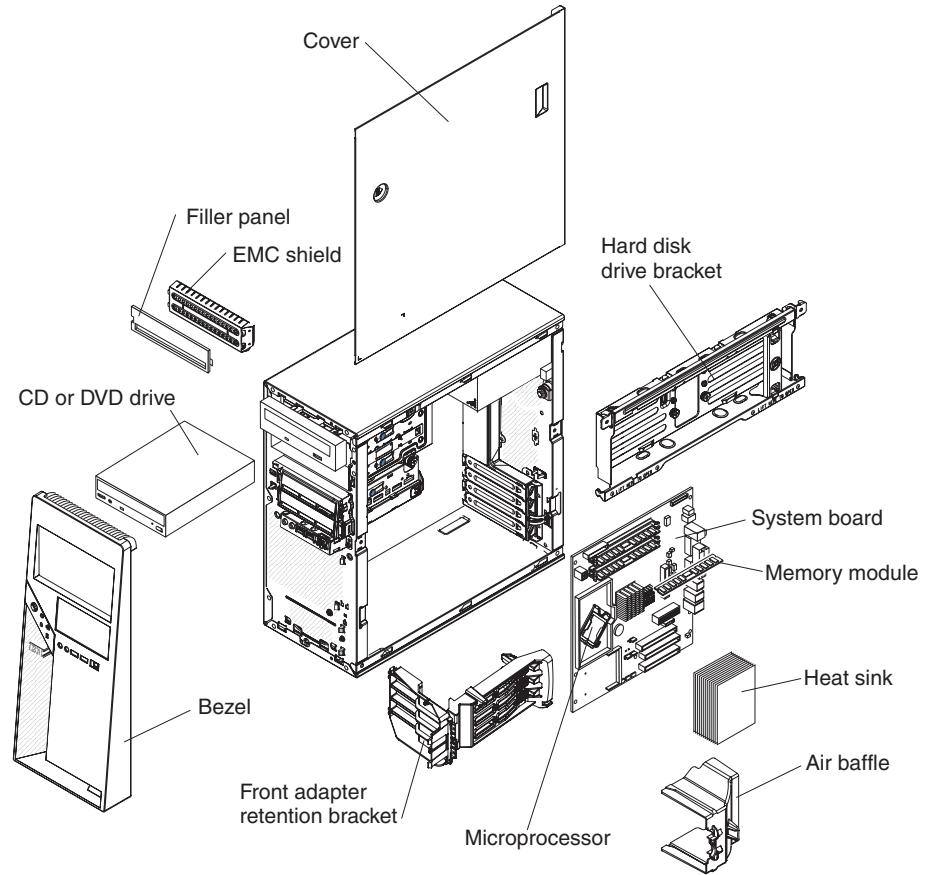

System-board option connectors

The following illustration shows the system-board connectors for user-installable options.

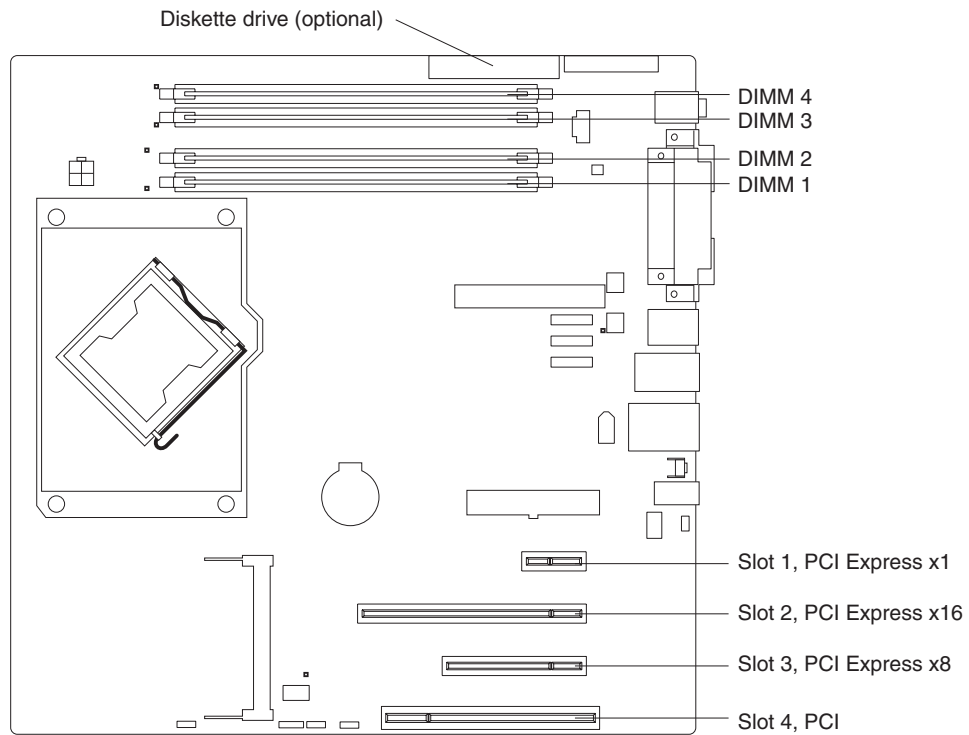

System-board internal connectors and jumpers

The following illustration shows the internal connectors, LEDs, and jumpers on the system board.

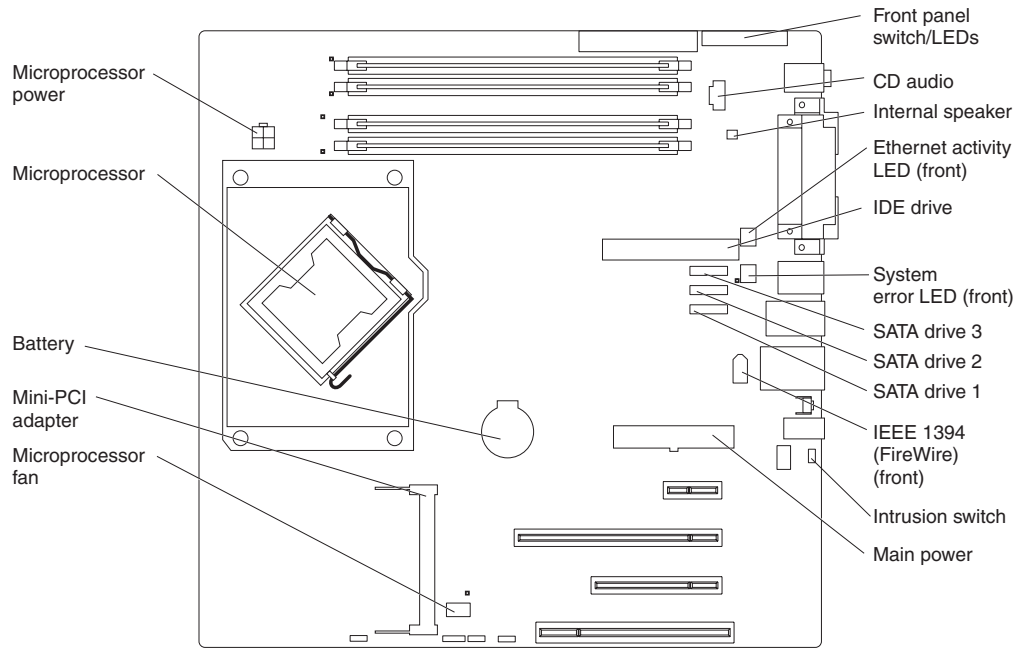

System-board external connectors

The following illustration shows the external input/output connectors on the system board.

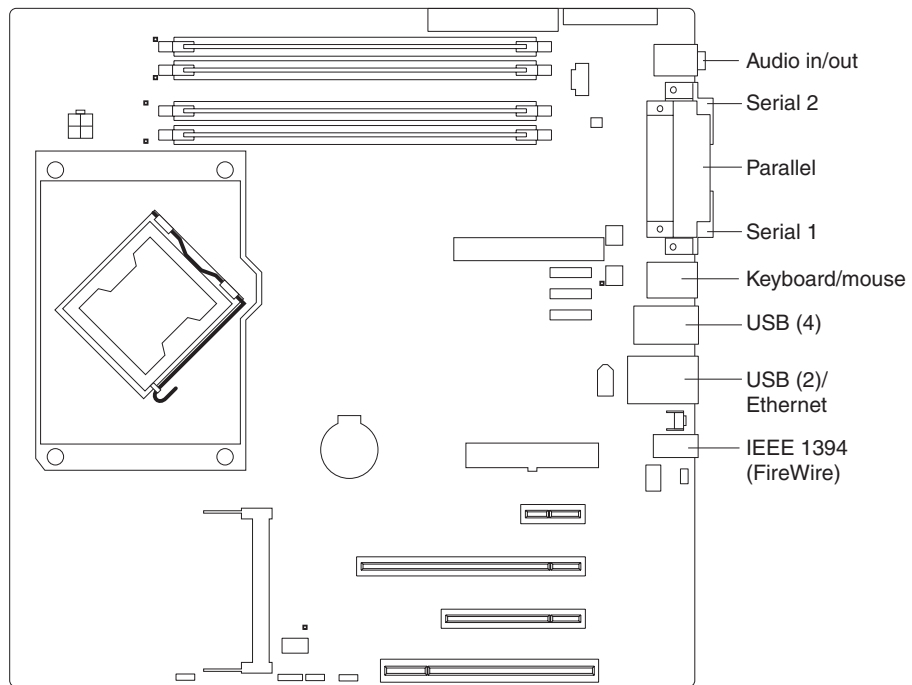

Removing the side cover

To remove the side cover of the computer, complete the following steps:

1. Read the safety information that begins on page vii and “Installation guidelines” on page 35.
2. Turn off the computer and all attached devices (see “Turning off the computer” on page 19); then, disconnect all power cords and external cables.
3. Press the cover-release button on the side of the computer, and push the side cover toward the rear of the computer. Lift the side cover off the computer and set it aside.

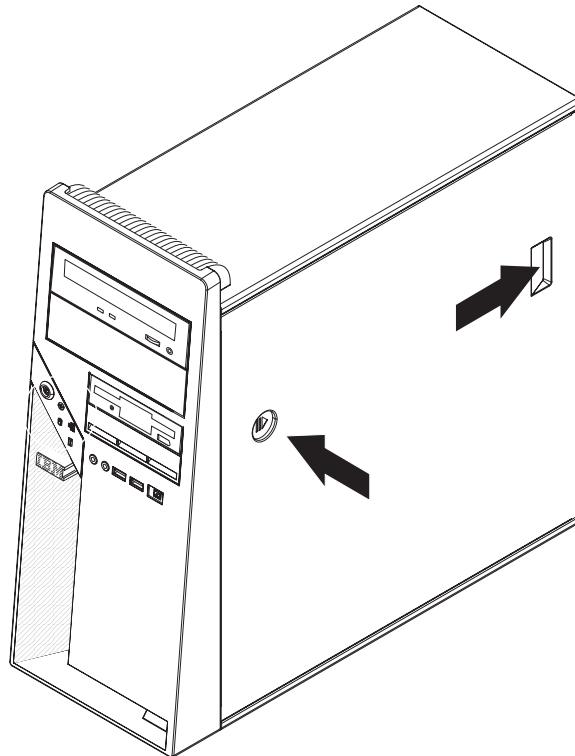

Attention: For proper cooling and airflow, replace the cover before turning on the computer. Operating the computer with the cover removed might damage computer components.

Removing the bezel

When working with some options, such as a CD or DVD drive or diskette drive, you must first remove the bezel to access the option.

To remove the bezel, complete the following steps:

1. Read the safety information that begins on page vii and the Installation guidelines on page 35.
2. Turn off the computer and all attached devices (see “Turning off the computer” on page 19); then, disconnect all power cords and external cables.
3. Remove the side cover (see “Removing the side cover” on page 41).
4. Press the bezel release button and pull the bottom of the bezel away from the chassis; then, lift the bezel to disengage the top tabs.

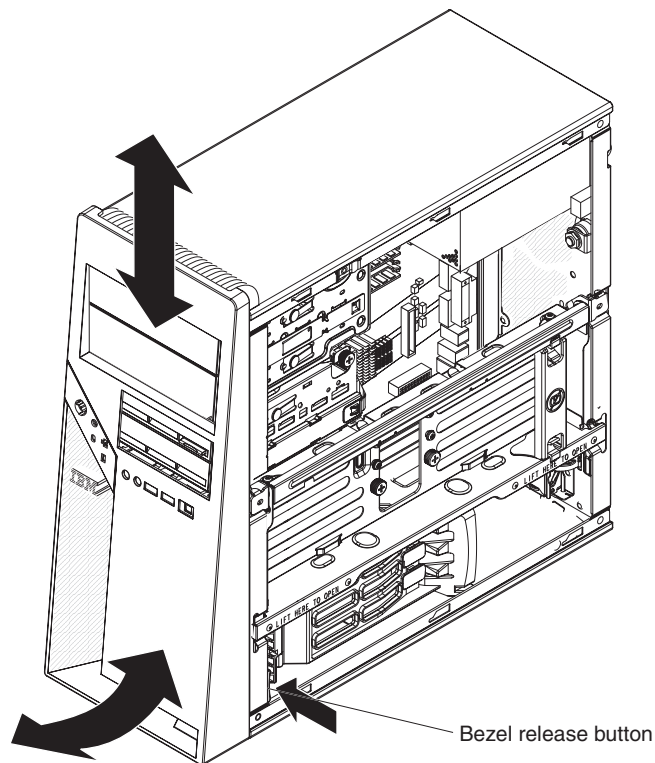

5. Carefully remove the bezel from the computer; then, set the bezel aside.

Removing the internal drive-bay bracket

Some models come with an optional internal drive-bay bracket. To remove the internal drive-bay bracket, complete the following steps:

1. Read the safety information that begins on page vii and Installation guidelines on page 35.
2. Turn off the computer and all attached devices (see “Turning off the computer” on page 19).
3. Remove the side cover (see “Removing the side cover” on page 41).
4. Disconnect the signal and power cables from the hard disk drive in the bracket.
5. Remove the two screws that fasten the top edge of the drive-bay bracket to the chassis.
6. Grasp the lower edge of the drive-bay bracket, and disengage it from the chassis.
7. Lift the top edge of the drive-bay bracket from the chassis and remove the drive-bay bracket from the computer.

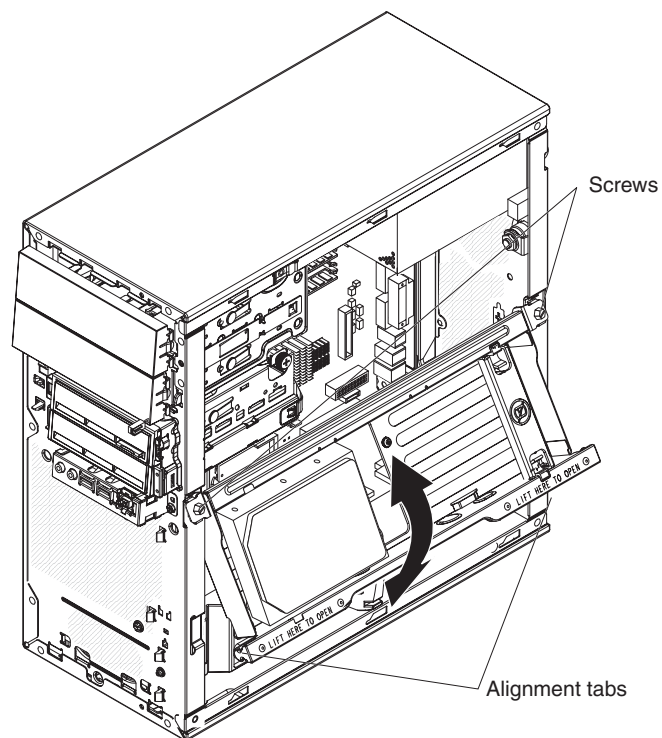

Removing the air baffle

The computer might come with an air baffle that directs air flow to the processor. When installing options, you might have to remove the air baffle to access some components.

To remove the air baffle, complete the following steps:

1. Press in on the tabs on each side of the air baffle.
2. Lift the air baffle out of the computer and set it aside.

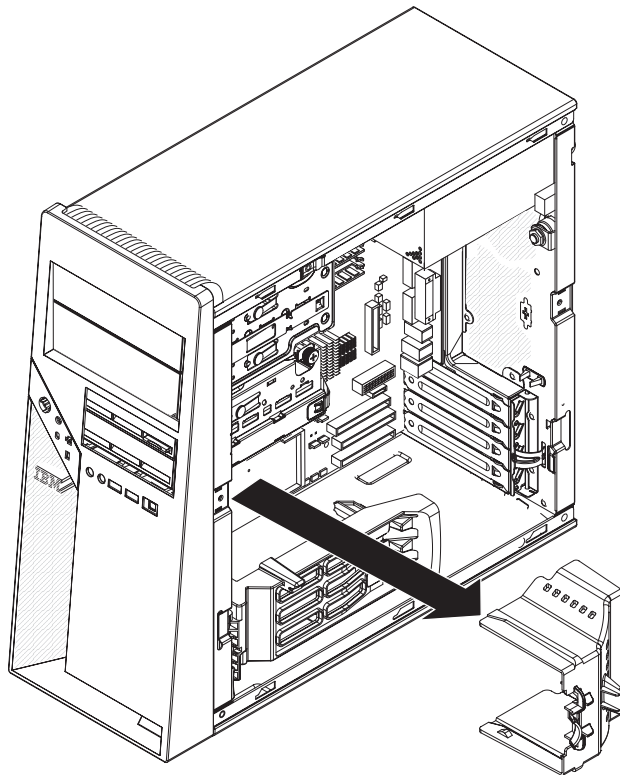

Installing an adapter

The following notes describe the types of adapters that the computer supports and other information that you might consider when installing an adapter. See “System-board option connectors” on page 38 for an illustration of the adapter slot locations.

- Read the documentation that comes with the operating system.
- Locate the documentation that comes with the adapter and follow those instructions in addition to the instructions in this chapter. If you have to change the switch or jumper settings on the adapter, follow the instructions that come with the adapter.
- The computer comes with the following adapter connectors, or *slots*:
 - Slot 1, PCI Express x1, 25 watt
 - Slot 2, PCI Express x16, 75 watt

Note: In some models the video adapter overlaps slot 1, PCI Express x1, that is next to it. Therefore, you will have one less PCI Express slot in which you can install an adapter.

- Slot 3, PCI Express x8, 25 watt

Important: Slot 3 supports x4 adapters and x8 adapters that can downshift to operate at the x4 bandwidth. If you install an x8 adapter that can downshift to the x4 bandwidth in slot 3, it will run at the x4 bandwidth. The x8 connector is used for x4 and x8 adapters. The *x8 (x4)* designation identifies an x8 slot that is designed to support x4 adapters and x8 adapters that can downshift to the x4 bandwidth. Check the information provided with your adapter for compatibility information.

- Slot 4, PCI 33/32

The computer comes with the video (graphics) adapter installed in slot 2. You can install up to three additional optional adapters in the computer.

- You can install only 33 MHz/32-bit adapters in slot 4.
- You can install full-length adapters in slots 3 and 4. None of the expansion slots are hot-plug slots.
- For slot 4, the computer supports 5.0 V signaling and universal PCI adapters; it does not support 3.3 V signaling adapters.
- To assign system resources, the computer scans the adapters in the following sequence:
 - Slot 1, PCI Express x1, 25 watt
 - Slot 2, PCI Express x16, 75 watt
 - Slot 3, PCI Express x8 (x4), 25 watt
 - Slot 4, PCI 33/32
 - The mini-PCI slot

The computer starts the PCI devices in the following order, if you have not changed the default startup sequence: slot 1, slot 2, system-board IDE, Serial ATA (SATA) or small computer system interface (SCSI) devices, slot 3, slot 4, and the mini-PCI slot.

- The computer comes with integrated IEEE 1394 (FireWire) support.
- For a list of supported options for the computer, go to <http://www.ibm.com/intellistation/>; then, select your country and navigate to the list of options for the computer.

To install an adapter, complete the following steps:

1. Read the safety information that begins on page vii and the Installation guidelines on page 35.
2. Turn off the computer and all attached devices (see “Turning off the computer” on page 19); then, disconnect all external cables and power cords.
3. Remove the side cover (see “Removing the side cover” on page 41).
4. Remove the internal drive-bay bracket (see “Removing the internal drive-bay bracket” on page 43).
5. Determine which PCI slot you will use for the adapter. Check the instructions that come with the adapter for any requirements, restrictions, or cabling instructions. It might be easier to route cables before you install the adapter.
6. If an adapter is already installed in the slot, remove it using the following procedure and place it on a static-protective surface:
 - For full-length adapters, rotate the rear adapter-retention bracket to the open (unlocked) position; then, release the adapter from the front adapter-retention bracket. Grasp the adapter and pull it out of the slot.

If the slot is empty, remove the expansion-slot cover. From the rear of the computer, press on the slot cover. Grasp it and pull it out of the expansion slot. Store it in a safe place for future use.

Attention: Expansion-slot covers must be installed in all empty slots. This maintains the electronic emissions standards of the computer and ensures proper ventilation of computer components.
7. Follow the instructions that come with the adapter to set jumpers or switches, if there are any.

Attention: Avoid touching the components and gold-edge connectors on the adapter.
8. If you are installing a full-length adapter, remove the blue adapter guide (if any) from the end of the adapter.

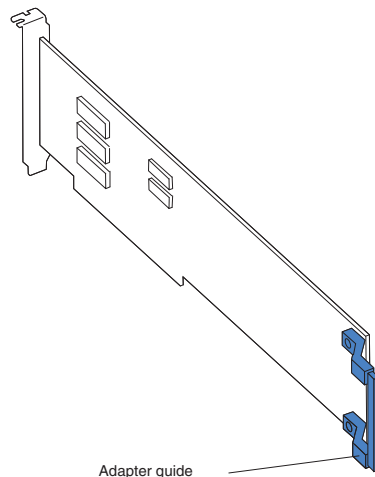

Attention: Make sure that the adapter is correctly seated in the expansion slot before you turn on the computer. Incomplete installation of an adapter might damage the system or the adapter.

- Carefully grasp the adapter by the top edge or upper corner and move the adapter directly from the static-protective package to the adapter slot. Align the adapter with the expansion slot guides; then, press the adapter *firmly* into the expansion slot.

Attention: Make sure that the adapter is correctly seated in the expansion slot before you turn on the computer. Incomplete installation of an adapter might damage the system board or the adapter.

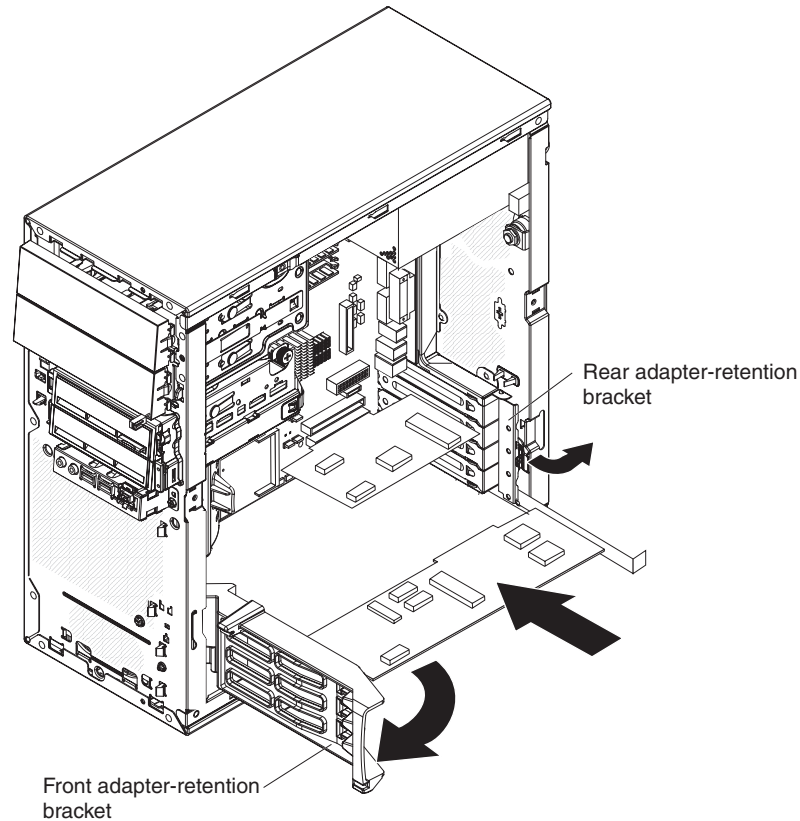

- Rotate the rear adapter-retention bracket to the closed (locked) position.
- Connect required cables to the adapter. Route cables so that they do not block the flow of air from the fans. If you are installing an optional SCSI adapter, see “Cabling an optional SCSI adapter” on page 48 for additional information.
- If you have another adapter to install, repeat steps 5 through 11.
- Press down on the top tab of the front adapter-retention bracket to lock it in place (the tab is inside the fan compartment that is next to the front adapter-retention bracket).

Note: If any adapter in the computer is large or has heavy cables attached to it, you can secure the adapter with a screw. Insert one backup expansion-slot screw through the top of each adapter bracket into the screw hole and secure the adapter before proceeding to the next step.

- If you have other options to install, do so now; otherwise, replace the internal drive-bay bracket (see “Replacing the internal drive-bay bracket” on page 65). Replace the side cover (see “Replacing the side cover” on page 67). Reconnect the external cables and power cords, and turn on the computer.

Cabling an optional SCSI adapter

You can install an optional SCSI adapter in the computer to control the internal hard disk drives. With a SCSI adapter installed, you can configure the internal hard disk drives into disk arrays. You can also cable a SCSI adapter to external hard disk drives. See the SCSI adapter option documentation for complete instructions for installing a SCSI adapter in the computer and for additional information about SCSI adapters.

Notes:

1. An optional SCSI adapter is required for you to connect external SCSI devices.
2. The SCSI cables that are used by the integrated SCSI controller cannot be used with an optional SCSI adapter.

To cable an optional SCSI adapter, complete the following steps:

1. Install the SCSI adapter (see “Installing an adapter” on page 45).
2. Connect the SCSI-signal cable to the adapter and one or more of the signal cable connectors to the rear of the SCSI devices.
3. Connect the SCSI-activity-indicator cable to the adapter and to the SCSI-LED connector on the system board.

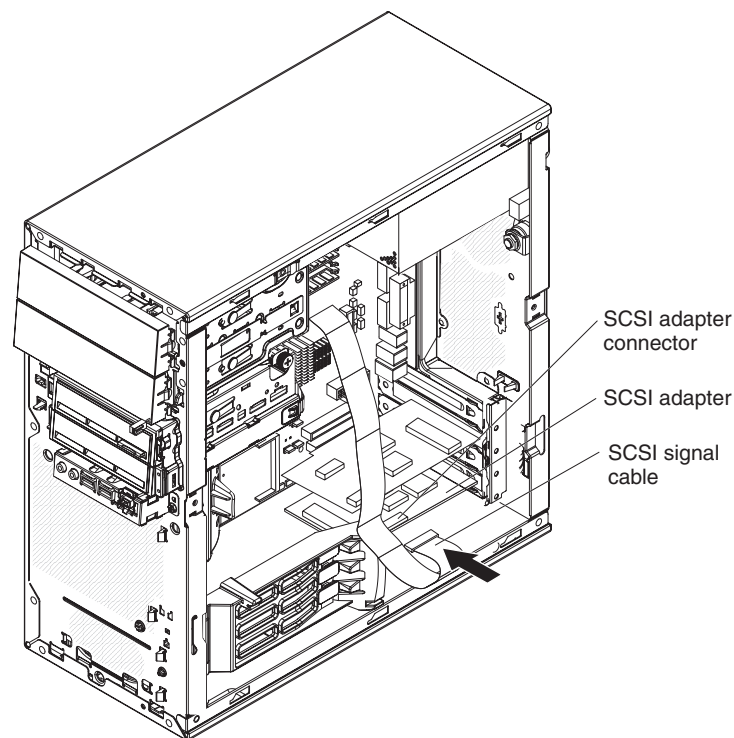

4. Complete the installation of the optional SCSI adapter.

Installing internal drives

Depending on the computer model, one or more of the following drives might be installed in the computer:

- Diskette (optional)
- Hard disk
- CD-RW, or DVD/CD-RW combo

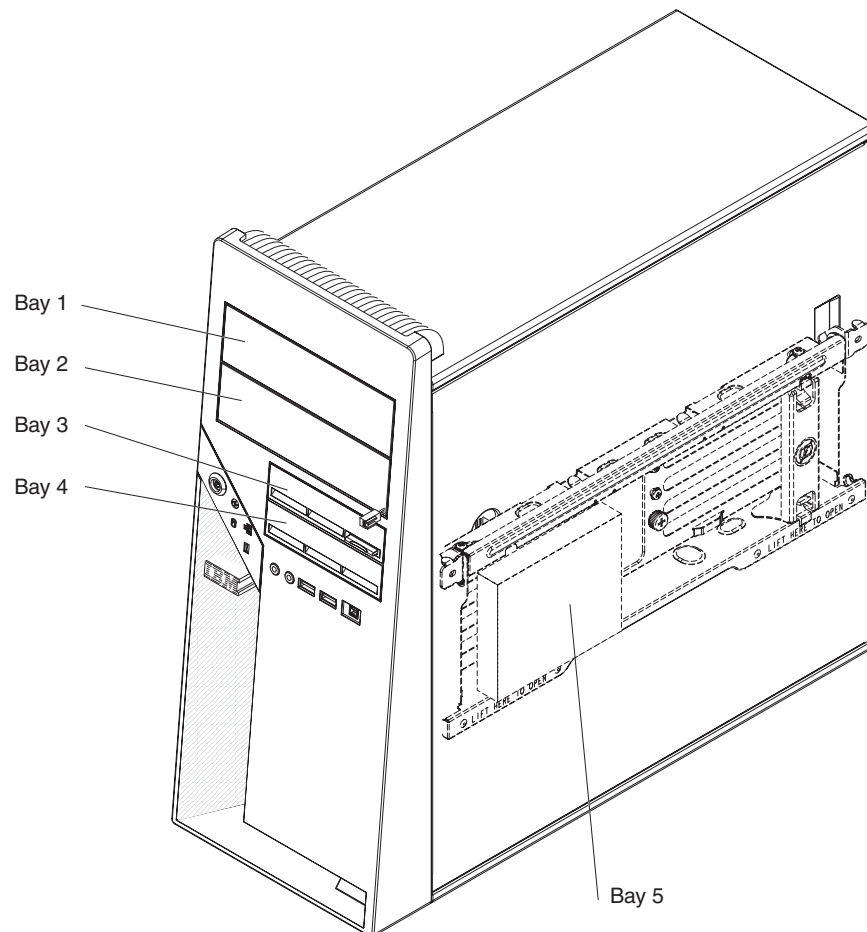

The following notes describe the types of drives that the computer supports and other information that you must consider when installing drives:

- The computer comes with an IDE optical drive in bay 1, and a hard disk drive in bay 4.
- Diskette drives, tape drives, CD-RW, DVD/CD-RW, and DVD-ROM drives are examples of removable-media drives. You can install removable-media drives in bays 1, 2, and 3 only.
- Mixing different types of hard disk drives is not supported. You can install all SATA, all SCSI, or all SAS disk drives, but you cannot mix them.
- You can install a 3.5-in. slim-high (requires conversion kit), or 5.25-in. half-high removable-media drive, such as a tape backup drive, in bay 2.
- The optional diskette drive can only be installed in bay 3.

- Some models come with an optional internal drive-bay bracket for the installation of a fifth drive (bay 5). Only one drive can be installed in this drive-bay bracket.
- Four SATA hard disk drives can be installed in the computer in bays 2, 3, 4, and 5. Install the SATA drives in this sequence: bay 4, bay 2, bay 3, and bay 5.
- SAS or Ultra320 SCSI hard disk drives can be installed in bays 2, 4, and 5. Install SAS or Ultra320 SCSI drives in this sequence: bay 4, 2, and 5.
- There are three SATA hard disk drive connectors on the system board.

Note: If you install the fourth SATA drive, you will need to install the optional ServeRAID-7t S-ATA controller. All SATA drives must then be connected to the ServeRAID-7t S-ATA controller, instead of the system board. The system board cannot support a fourth SATA drive. The optional ServeRAID-7t S-ATA controller comes with two additional cables. See the optional ServeRAID-7t S-ATA controller documentation for cabling instructions.

- The electromagnetic interference (EMI) integrity and cooling of the computer are protected by having all bays and PCI slots covered or occupied. When you install a drive or PCI adapter, save the EMC shield and filler panel from the bay or the PCI adapter slot cover in the event you later remove the drive or adapter.
- For a complete list of supported options for the computer, go to <http://www.ibm.com/intellistation/>; then, select your country and navigate to the list of options for the computer.

Installing a removable media drive in bay 2

To install a drive in bay 2, complete the following steps:

Note: When installing options, you might find it easier to work with the computer lying on its side.

1. Read the safety information that begins on page vii, the Installation guidelines on page 35, and the documentation that comes with the drive.
2. Turn off the computer and all attached devices; then, disconnect all external cables and power cords.
3. Remove the side cover (see “Removing the side cover” on page 41).
4. Remove the bezel (see “Removing the bezel” on page 42).
5. Remove the internal drive-bay bracket (see “Removing the internal drive-bay bracket” on page 43).

6. Use a screwdriver to pry the filler panel and EMC shield away from the computer.

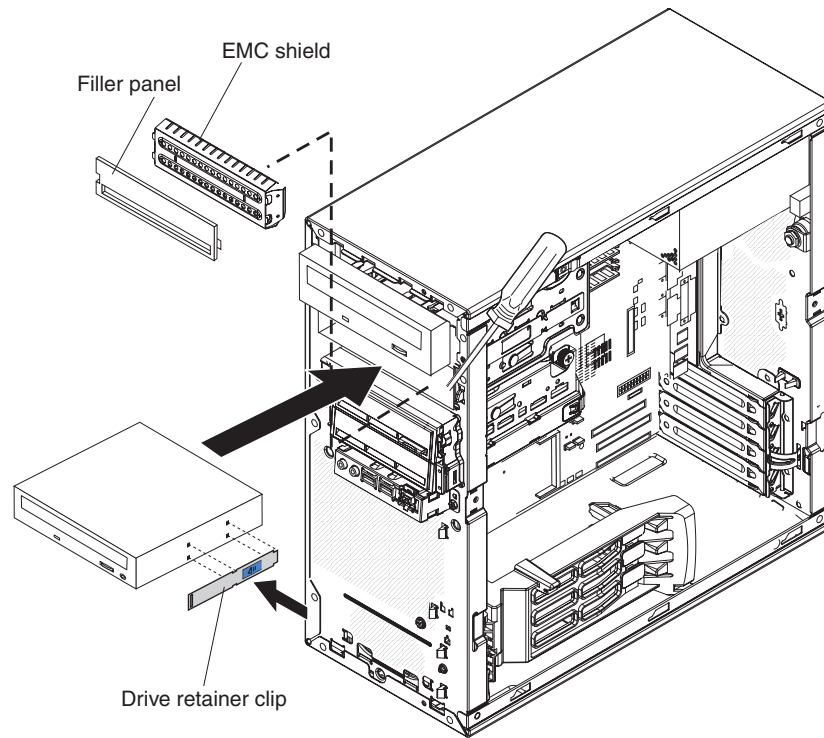

Note: If you are installing a drive that contains a laser, observe the following safety precaution.

Statement 3:



CAUTION:

When laser products (such as CD-ROMs, DVD drives, fiber optic devices, or transmitters) are installed, note the following:

- Do not remove the covers. Removing the covers of the laser product could result in exposure to hazardous laser radiation. There are no serviceable parts inside the device.
- Use of controls or adjustments or performance of procedures other than those specified herein might result in hazardous radiation exposure.



DANGER

Some laser products contain an embedded Class 3A or Class 3B laser diode. Note the following.

Laser radiation when open. Do not stare into the beam, do not view directly with optical instruments, and avoid direct exposure to the beam.

Class 1 Laser Product
Laser Klasse 1
Laser Class 1
Luokan 1 Laserlaite
Appareil À Laser de Classe 1

7. Touch the static-protective package that contains the drive to any unpainted metal surface on the computer; then, remove the drive from the package and place it on a static-protective surface.
8. Set any jumpers or switches on the drive according to the documentation that comes with the drive.
9. Remove the large drive retainer clip that is attached to the inside of the top portion of the bezel door. Pull outward (to the left), on the drive retainer clip release tab, to release the drive retainer clip and lift it off the bezel.

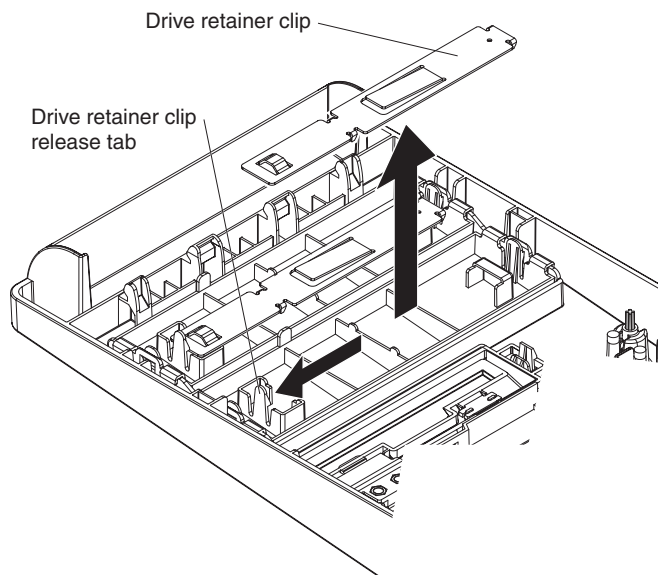

10. Install the blue drive retainer clip into the screw holes on the side of the drive (with the blue side of the clip facing outward).

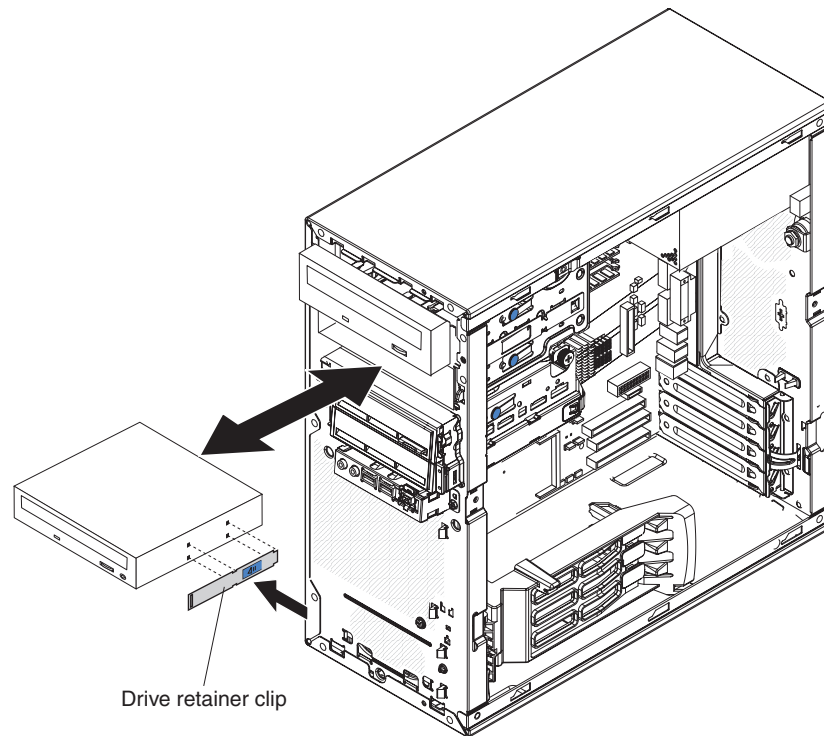

11. Slide the drive into the front of the bay until it snaps in place.
12. Route the signal cable so that it does not block the airflow to the rear of the drives or over the microprocessor.
13. Connect the power cable to the back of the drive. The connectors are keyed and can be inserted only one way.
14. Replace the internal drive-bay bracket (see “Replacing the internal drive-bay bracket” on page 65).
15. Replace the bezel (see “Replacing the bezel” on page 66).
16. Replace the side cover (see “Replacing the side cover” on page 67).
17. Reconnect the external cables and power cords.
18. Turn on the attached devices and the computer.

Installing an optional diskette drive in bay 3

To install a drive in bay 3, complete the following steps:

1. Read the safety information that begins on page vii, the Installation guidelines on page 35, and the documentation that comes with the drive.
2. Turn off the computer and all attached devices; then, disconnect all external cables and power cords.
3. Remove the side cover (see “Removing the side cover” on page 41).
4. Remove the bezel (see “Removing the bezel” on page 42).
5. Remove the internal drive-bay bracket (see “Removing the internal drive-bay bracket” on page 43).

6. Use a screwdriver to pry the filler panel and EMC shield away from the computer, (see the illustration in step 6 on page 51).

Note: If you are installing a drive that contains a laser, observe the following safety precaution.

Statement 3:



CAUTION:

When laser products (such as CD-ROMs, DVD drives, fiber optic devices, or transmitters) are installed, note the following:

- Do not remove the covers. Removing the covers of the laser product could result in exposure to hazardous laser radiation. There are no serviceable parts inside the device.
- Use of controls or adjustments or performance of procedures other than those specified herein might result in hazardous radiation exposure.



DANGER

Some laser products contain an embedded Class 3A or Class 3B laser diode. Note the following.

Laser radiation when open. Do not stare into the beam, do not view directly with optical instruments, and avoid direct exposure to the beam.

Class 1 Laser Product
Laser Klasse 1
Laser Klass 1
Luokan 1 Laserlaite
Appareil À Laser de Classe 1

7. Touch the static-protective package that contains the drive to any unpainted metal surface on the computer; then, remove the drive from the package and place it on a static-protective surface.
8. Remove the small drive retainer clip that is attached to the bottom of the drive cage. Slide the drive retainer clip to disengage it from the drive cage; then, snap the drive retainer clip into the screw holes on the side of the drive.
9. Slide the drive into the front of the bay until it snaps in place.

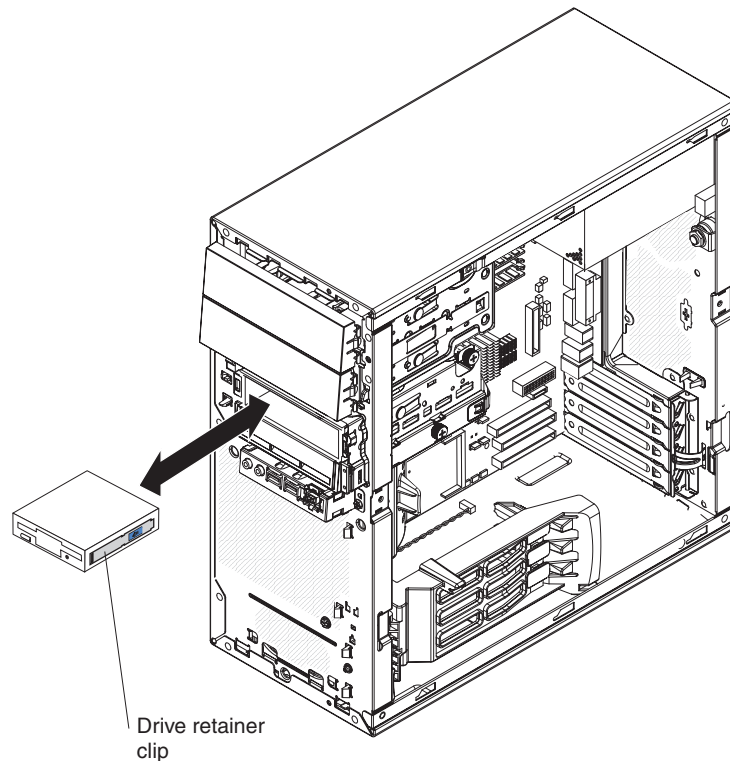

10. Route the signal cable so that it does not block the airflow to the rear of the drives or over the microprocessor.
11. Connect the power cable to the back of the drive. The connectors are keyed and can be inserted only one way.
12. Replace the internal hard disk drive bracket (see “Replacing the internal drive-bay bracket” on page 65).
13. Replace the bezel (see “Replacing the bezel” on page 66).
14. Replace the side cover (see “Replacing the side cover” on page 67).
15. Reconnect the external cables and power cords.
16. Turn on the attached devices and the computer.

Installing a SATA drive in bay 3

To install a SATA drive in bay 3, complete the following steps:

1. Read the safety information that begins on page vii, the Installation guidelines on page 35, and the documentation that comes with the drive.
2. Turn off the computer and all attached devices; then, disconnect all external cables and power cords.
3. Remove the side cover (see “Removing the side cover” on page 41).
4. Remove the bezel (see “Removing the bezel” on page 42).
5. Remove the internal drive-bay bracket (see “Removing the internal drive-bay bracket” on page 43).

6. Use a screwdriver to pry the filler panel and EMC shield away from the computer, (see the illustration in step 6 on page 51).

Note: If you are installing a drive that contains a laser, observe the following safety precaution.

Statement 3:



CAUTION:

When laser products (such as CD-ROMs, DVD drives, fiber optic devices, or transmitters) are installed, note the following:

- Do not remove the covers. Removing the covers of the laser product could result in exposure to hazardous laser radiation. There are no serviceable parts inside the device.
- Use of controls or adjustments or performance of procedures other than those specified herein might result in hazardous radiation exposure.



DANGER

Some laser products contain an embedded Class 3A or Class 3B laser diode. Note the following.

Laser radiation when open. Do not stare into the beam, do not view directly with optical instruments, and avoid direct exposure to the beam.

Class 1 Laser Product
Laser Klasse 1
Laser Klass 1
Luokan 1 Laserlaite
Appareil À Laser de Classe 1

7. Touch the static-protective package that contains the drive to any unpainted metal surface on the computer; then, remove the drive from the package and place it on a static-protective surface.

8. Install the hard disk drive into the drive bay with the screws that come with the drive.

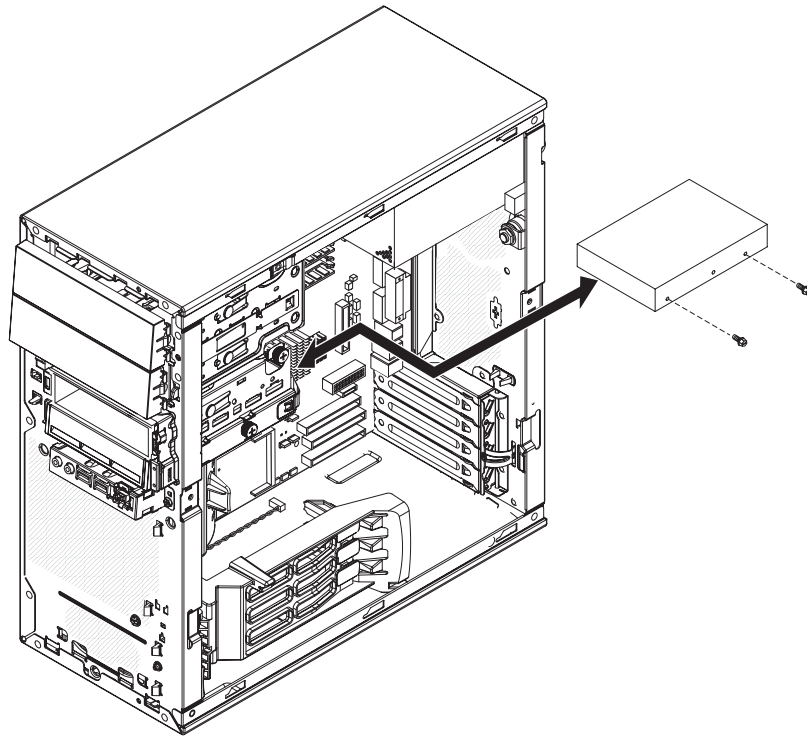

9. Slide the drive into the drive bay until it snaps in place.
10. Route the signal cable so that it does not block the airflow to the rear of the drives or over the microprocessor.
11. Connect the power cable to the back of the drive. The connectors are keyed and can be inserted only one way.
12. Replace the internal hard disk drive bracket (see “Replacing the internal drive-bay bracket” on page 65).
13. Replace the bezel (see “Replacing the bezel” on page 66).
14. Replace the side cover (see “Replacing the side cover” on page 67).
15. Reconnect the external cables and power cords.
16. Turn on the attached devices and the computer.

Installing a Ultra320 SCSI, SATA, or SAS drive in bay 2 or 4

To install a hard disk drive in bay 2 or 4, complete the following steps:

1. Read the safety information that begins on page vii, the Installation guidelines on page 35, and the documentation that comes with the drive.
2. Turn off the computer and all attached devices; then, disconnect all external cables and power cords.
3. Remove the side cover (see “Removing the side cover” on page 41).
4. Remove the bezel (see “Removing the bezel” on page 42).
5. Remove the internal drive-bay bracket (see “Removing the internal drive-bay bracket” on page 43).

6. Use a screwdriver to pry the filler panel and EMC shield away from the computer, (see the illustration in step 6 on page 51).

Note: If you are installing a drive that contains a laser, observe the following safety precaution.

Statement 3:



CAUTION:

When laser products (such as CD-ROMs, DVD drives, fiber optic devices, or transmitters) are installed, note the following:

- Do not remove the covers. Removing the covers of the laser product could result in exposure to hazardous laser radiation. There are no serviceable parts inside the device.
- Use of controls or adjustments or performance of procedures other than those specified herein might result in hazardous radiation exposure.



DANGER

Some laser products contain an embedded Class 3A or Class 3B laser diode. Note the following.

Laser radiation when open. Do not stare into the beam, do not view directly with optical instruments, and avoid direct exposure to the beam.

Class 1 Laser Product
Laser Klasse 1
Laser Klass 1
Luokan 1 Laserlaite
Appareil À Laser de Classe 1

7. Touch the static-protective package that contains the drive to any unpainted metal surface on the computer; then, remove the drive from the package and place it on a static-protective surface.
8. Set any jumpers or switches on the new drive according to the documentation that comes with the drive.
9. Install the hard disk drive onto the hard disk drive tray, with the screws that come with the drive. Slide the drive into the bay until it snaps into place. If you are replacing the drive in bay 4, use the captured thumbscrew that you received earlier, to attach the drive to the chassis.

Note: If you are installing the drive in bay 2, attach a 5.25-in. conversion kit to the 3.5-in. drive.

10. Determine whether the drive is a SATA, SCSI, or SAS device; then, connect one end of the applicable signal cable into the back of the drive and make sure that the other end of this cable is connected into the applicable SATA, SCSI, or SAS connector.
11. Route the signal cable so that it does not block the airflow to the rear of the drives or over the microprocessor.
12. Replace the hard disk drive bracket (see “Replacing the internal drive-bay bracket” on page 65).
13. Connect the power cable to the back of the drive. The connectors are keyed and can be inserted only one way.
14. Replace the bezel (see “Replacing the bezel” on page 66).
15. Replace the side cover (see “Replacing the side cover” on page 67).
16. Reconnect the external cables and power cords.
17. Turn on the attached devices and the computer.

Installing an Ultra320 SCSI, SATA, or SAS drive in bay 5

To install a hard disk drive in bay 5, complete the following steps:

1. Install the two shoulder screws, one on each side, at the front of the new drive.

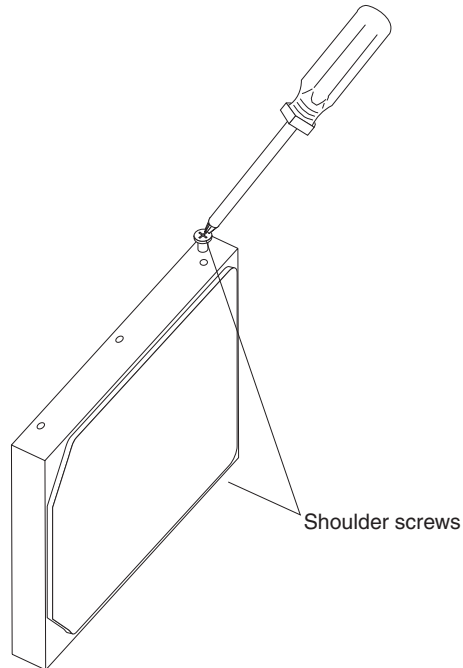

2. Position the hard disk drive so that the shoulder screws are aligned with the slots in the hard disk drive bracket.

3. Slide the front of the drive into the slots of the hard disk drive bracket.

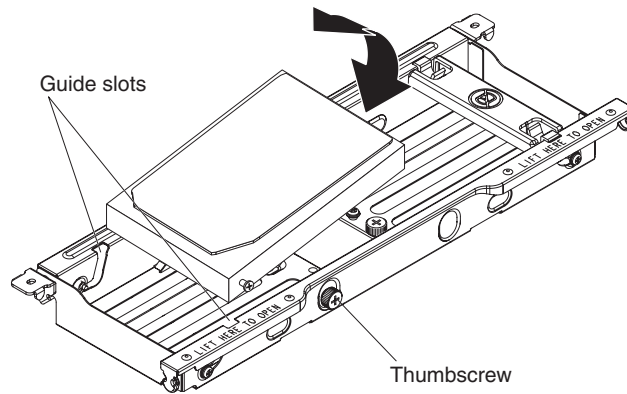

4. Lower the rear of the drive into position in the bracket, and install the thumbscrew at the rear of the drive.
5. Reconnect the signal and power cables to the hard disk drive in the bracket.
6. Replace the internal drive-bay bracket, see “Replacing the internal drive-bay bracket” on page 65.
7. Replace the bezel, see “Replacing the bezel” on page 66.
8. Replace the side cover (see “Replacing the side cover” on page 67).
9. Reconnect the external cables and power cords.
10. Turn on the attached devices, and turn on the computer.

Power and signal cables for internal drives

Important:

This computer is suitable for use on an IT power distribution system, whose maximum phase to phase voltage is 240 V under any distribution fault condition.

The computer uses cables to connect IDE, SATA, SCSI, and SAS devices to the power supply and to the system board. (See “System-board internal connectors and jumpers” on page 39 for the location of system-board connectors.) Review the following information before connecting power and signal cables to internal drives:

- The drives that are preinstalled in the computer come with power and signal cables attached. If you replace any drives, remember which cable is attached to which drive.
- When you install a drive, make sure that one of the drive connectors of the signal cable is connected to the drive and that the connector at the other end of the signal cable is connected to the system board.
- If you have only one IDE device on a cable, it must be set as a primary device.

- If two IDE devices are used on a single cable, one must be designated as the primary device and the other as the secondary device; otherwise, the computer might not recognize some of the IDE devices. The primary and secondary designation is determined by switch or jumper settings on each IDE device.

The following cables are provided:

- **Power cables:** Four-wire power cables connect the drives to the power supply. At the end of these cables are plastic connectors that can be attached to different drives; these connectors vary in size. You can use either a four-wire power cable or serial ATA power cable with serial ATA drives, but do not use both at the same time (use one or the other).
- **Signal cables:** Signal cables are typically flat cables, also called ribbon cables, that connect parallel IDE, SATA, SCSI, SAS and diskette drives to the system board. Two or three types of signal cable come with the computer:
 - **IDE:** The wider IDE signal cable has three connectors. One of these connectors is attached to the drive, one is a spare, and the third is attached to the primary IDE connector on the system board.
The optical drive is attached to an ATA 100 signal cable. ATA 100 signal cables are color-coded. The blue connector is attached to the system board. The black connector is attached to the primary IDE device. The gray middle connector is attached to the secondary IDE device.
 - **Diskette drive (optional):** The narrower signal cable has two connectors. One is attached to the diskette drive, and the other is attached to the diskette drive connector on the system board.
 - **Serial ATA:** The narrower, black signal cable has two connectors. One is attached to the SATA drive, and the other is attached to the connector on the system board. Each SATA drive comes with a cable. If you install an additional SATA drive, you will need an additional cable. SATA signal cables should be connected to the system board connectors (SATA 0 through SATA 2) in numerical order, starting with SATA 0.
If you install the fourth SATA drive, you will need to install the optional ServeRAID-7t S-ATA controller. All SATA drives must then be connected to the ServeRAID-7t S-ATA controller, instead of the system board. The optional ServeRAID-7t S-ATA controller comes with two additional cables. See the optional ServeRAID-7t S-ATA controller documentation for cabling instructions. The system board cannot support the fourth SATA drive.
 - **SCSI:** The Ultra320 twisted ribbon cable connects the internal Ultra320 SCSI hard disk drive to the mini-PCI SCSI connector. This cable has three additional connectors for attaching more internal SCSI devices.
 - **SAS:** The SAS flat three-drop cable connects the internal SAS hard disk drive to the SAS mini-PCI connector. This cable has three connectors for attaching three internal SAS devices.

Installing memory modules

The following notes describe the types of dual inline memory modules (DIMMs) that the computer supports and other information that you must consider when installing DIMMs:

- When you restart the computer after adding or removing a DIMM, the computer displays a message that the memory configuration has changed.
- The computer uses industry-standard PC2-4200 double-data-rate 2 (DDR2) DIMMs.
- The system board contains four DIMM connectors and supports two-way memory interleaving.
- The DIMM options that are available for the computer are 512 MB, 1 GB, and 2 GB, which come in matched pairs. The computer supports a minimum of 1GB and a maximum of 8 GB of system memory.
- The computer comes with either two 512 MB or two 1 GB memory DIMMs installed in the DIMM 1 and DIMM 3 connectors. The second pair of DIMMs must be installed in the DIMM 2 and DIMM 4 connectors.
- DIMMs must be installed in matched pairs. The DIMMs in each pair must be the same size, speed, type, and technology as each other but do not have to match the other pairs. You can mix compatible DIMMs from various manufacturers.
- Install only 1.8 V, 240-pin, DDR2, PC2-4200, unbuffered synchronous dynamic random-access memory (SDRAM) with error correcting code (ECC) DIMMs. These DIMMs must be compatible with the latest PC2-4200 SDRAM, unbuffered DIMM specification. For a list of supported options for the computer, go to <http://www.ibm.com/intellistation/>; then, select your country and navigate to the list of options for the computer.
- The amount of usable memory will be reduced depending on the system configuration. A certain amount of memory must be reserved for system resources. The BIOS will display the total amount of installed memory and the amount of configured memory.

To install a DIMM, complete the following steps:

1. Read the safety information that begins on page vii, and the Installation guidelines on page 35.
2. Turn off the computer and all attached devices (see “Turning off the computer” on page 19); then, disconnect all power cords and external cables.
3. Remove the side cover (see “Removing the side cover” on page 41).
4. Remove the bezel, (see “Removing the bezel” on page 42).
5. For easier access, place the computer on its side.
6. Remove the internal drive bay bracket, (see “Removing the internal drive-bay bracket” on page 43).
7. Locate the DIMM connectors on the system board. Determine the connectors into which you will install the DIMMs. Remember that DIMM 1 and DIMM 3 must be paired together (and must be the first installed pair) and DIMM 2 and DIMM 4 must be paired together. The following table shows the installation sequence.

Memory installation sequence	
DIMMs	Slots
2 DIMMs	1, 3
4 DIMMs	1, 3, 2, 4

8. Gently open the retaining clips and, if necessary, remove any existing DIMM.
Attention: To avoid breaking the retaining clips or damaging the DIMM connectors, open and close the clips gently
9. Touch the static-protective package that contains the DIMM to any unpainted metal surface on the computer. Then, remove the new DIMM from the package.
10. Gently open the retaining clip on each end of the DIMM slot. Turn the DIMM so that the pins align correctly with the connector.
11. Insert the DIMM into the connector. Firmly press the DIMM straight down into the connector by applying pressure on both ends of the DIMM simultaneously. The retaining clips snap into the locked position when the DIMM is firmly seated in the connector. If there is a gap between the DIMM and the retaining clips, the DIMM has not been correctly installed. Open the retaining clips and remove the DIMM; then, reinsert it.

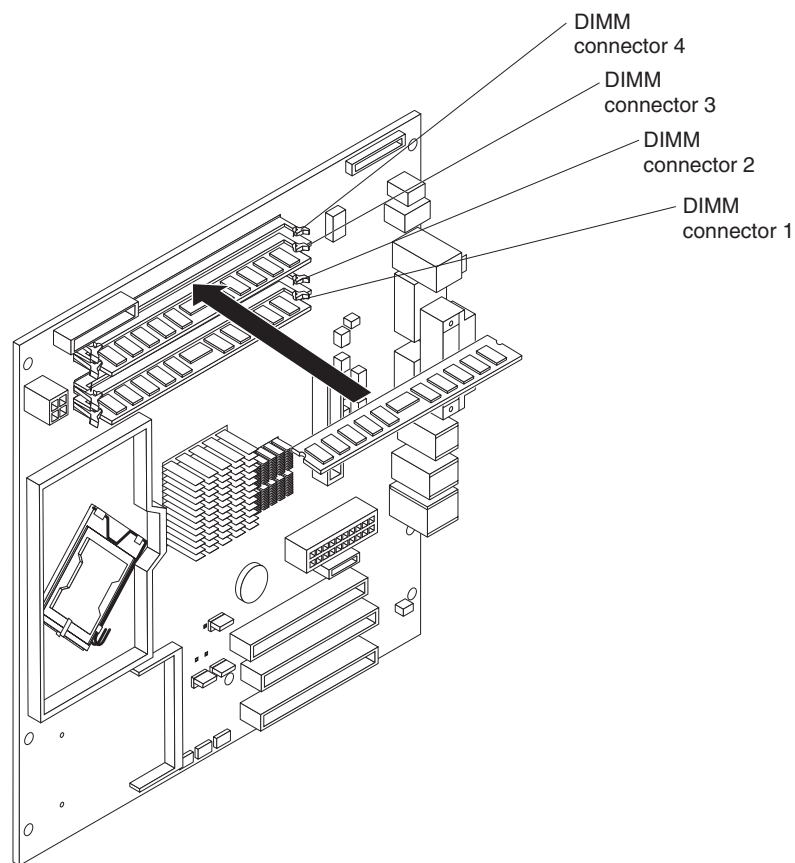

12. If you have other options to install or remove, do so now; otherwise rotate the cage back into the computer.
13. Replace the internal drive-bay bracket, (see “Replacing the internal drive-bay bracket” on page 65).
14. Return the computer to the upright position.
15. Replace the bezel, (see “Replacing the bezel” on page 66).
16. Replace the side cover (see “Replacing the side cover” on page 67).
17. Reconnect the external cables and power cords. Turn on the attached devices, and turn on the computer.

Installing a security cable

To help prevent hardware theft, you can thread a security cable through the cable loop on the rear of the computer. After you add the security cable, make sure that it does not interfere with other cables that are connected to the computer.

Before you begin, obtain the following items:

- A security cable
- A lock, such as a combination lock or padlock

To install a security cable, complete the following steps:

1. Thread the cable through the cable loop and around an object that is not part of or permanently secured to the building structure or foundation and from which the cable cannot be removed.
2. Fasten the cable ends together with a lock. Make sure that the cable does not interfere with other cables that are connected to the computer.

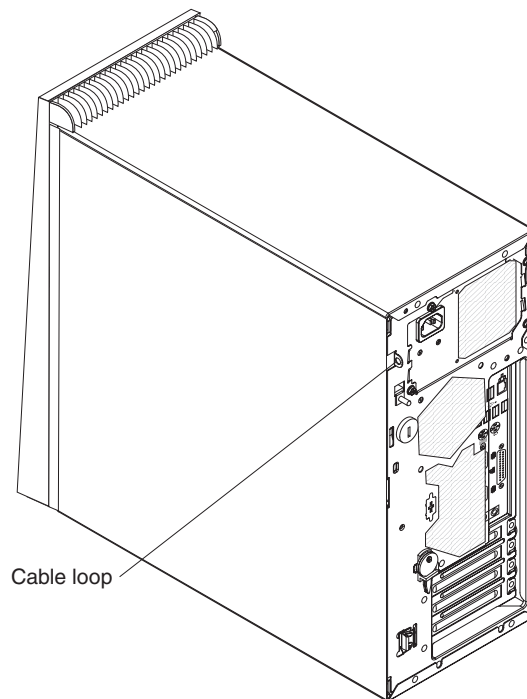

Replacing the air baffle

To replace the air baffle, complete the following steps:

1. Place the air baffle directly over the front fan unit.
2. Press the air baffle down until it snaps in place over the front fan unit. When the air baffle is correctly seated, the right edge of the air baffle rests on the left edge of the heat sink.

Replacing the internal drive-bay bracket

To install the internal drive-bay bracket, complete the following steps:

1. Place the top edge of the drive-bay bracket into place on the chassis. Rotate the drive-bay bracket downward until it engages in the chassis.
2. Install the two screws that fasten the top edge of the drive-bay bracket to the chassis.
3. If you removed the hard disk drive while removing the drive-bay bracket, install the hard disk drive now (see “Installing an Ultra320 SCSI, SATA, or SAS drive in bay 5” on page 59).
4. Reconnect the signal and power cables to the hard disk drive in the drive-bay bracket.
5. Replace the side cover (see “Replacing the side cover” on page 67).
6. Reconnect the external cables and power cords.
7. Turn on the attached devices, and turn on the computer.

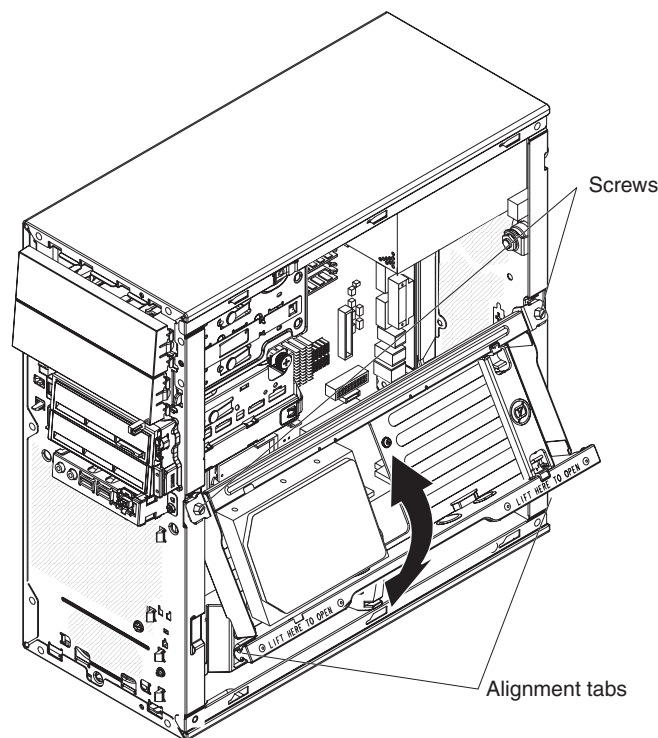

Replacing the bezel

To replace the bezel, complete the following steps:

1. Insert the two tabs on the top back of the bezel into the matching holes on the computer chassis above bay 1.
2. Push the bottom of the bezel toward the computer until the two tabs at the bottom of the bezel snap into place.

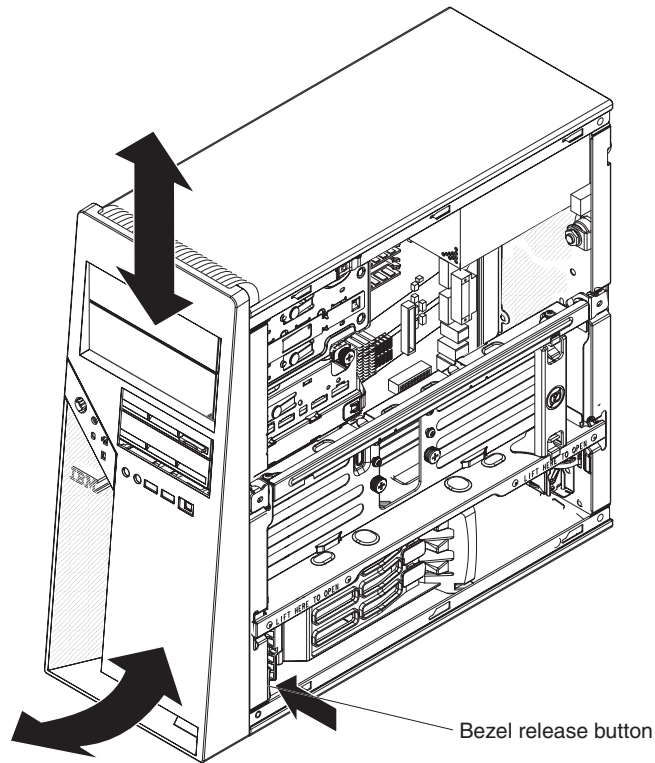

Replacing the side cover

To replace the side cover, complete the following steps:

1. Make sure that all cables, adapters, and other components are installed and seated correctly and that you have removed all work tools or parts from inside the computer.
2. Install the side cover by placing it into position on the computer. Make sure that the lip on the bottom of the cover rests on the ledge on the bottom of the chassis. Slide the side cover forward to lock the side cover.

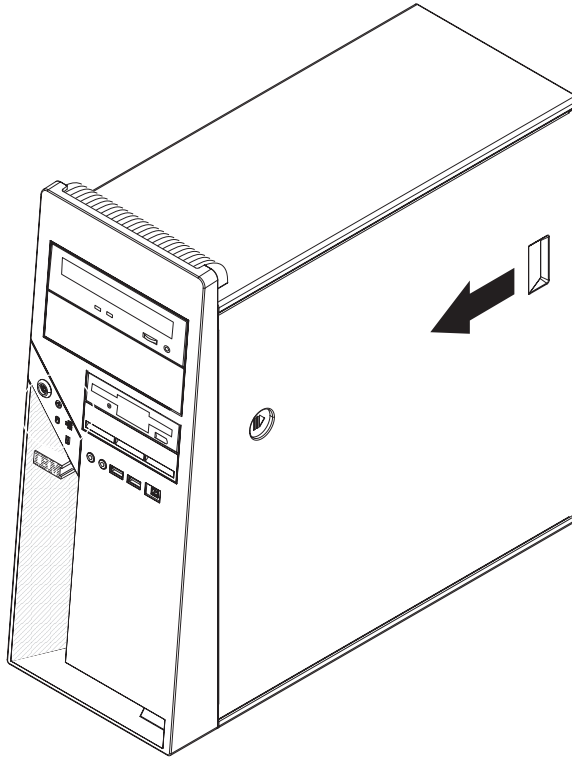

3. Reconnect the external cables and power cords to the computer; then, connect the power cords to electrical outlets.
4. Turn on the attached devices; then, turn on the computer.

Connecting external options

You can connect a number of optional external devices to the connectors on the rear and front of the computer.

To connect an external device, complete the following steps:

1. Read the safety information that begins on page vii, the Installations guidelines on page 35, and the documentation that comes with the device.
2. Turn off the computer and all attached devices (see “Turning off the computer” on page 19).
3. Follow the instructions that come with the device to prepare it for installation and to connect it to the computer.

If you are attaching a SCSI device, see “Ultra320 SCSI connector” on page 71 for SCSI ID and cabling information.

Input/output connectors

Connect optional external devices to the connectors on the front and rear of the computer.

The computer has the following input/output (I/O) connectors:

- One audio line in
- Two audio line out
- One audio microphone
- One Ethernet
- Two IEEE 1394 (FireWire)
- One keyboard
- One mouse
- One parallel
- Two serial
- Eight Universal Serial Bus (USB) 2.0
- One video

The following illustration shows the locations of the connectors on the rear of the computer.

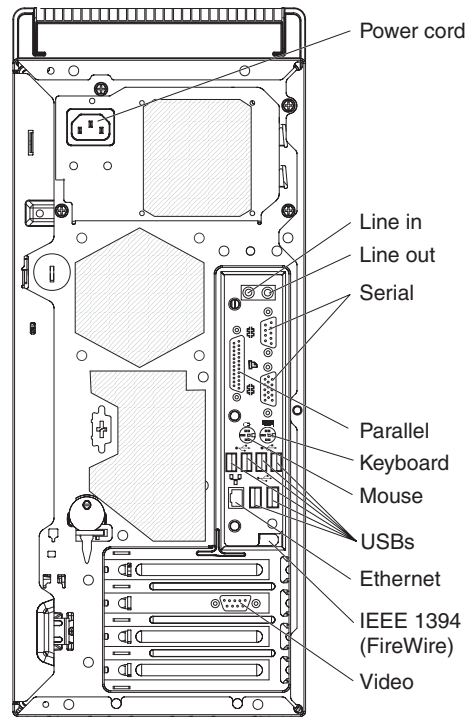

The following sections describe these connectors.

Audio connectors

Use the audio connectors to connect external audio equipment to the computer. The following illustration shows the audio connectors.

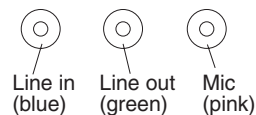

Line in

There is one line-in connector on the rear of the computer. The computer receives audio signals through this connector from an external audio device.

Line out

There are two line-out connectors, one on the front and one on the rear of the computer. The computer sends audio signals through this connector to powered speakers with built-in amplifiers, headphones, a multimedia keyboard, or the audio line-in connector on a stereo system. The internal speaker in the computer is disabled when a device is attached to this connector.

Mic

There is one microphone connector on the front of the computer. Connect a microphone to this connector to record sounds onto the hard disk or to use speech-recognition software.

Auxiliary-device (pointing-device) connector

There is one auxiliary-device connector on the rear of the computer. Use this connector to connect a mouse or other pointing device. The following illustration shows an auxiliary-device connector.

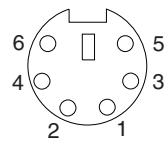

Ethernet (RJ-45) connector

There is one Ethernet connector on the rear of the computer. Use this connector to connect the computer to a 10-Mbps, 100-Mbps, or 1000-Mbps network. The following illustration shows an Ethernet connector.

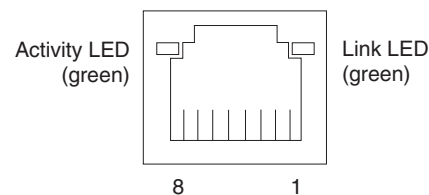

Connect a Category 3, 4, or 5 unshielded twisted-pair (UTP) cable to this connector. The 100BASE-TX and 1000BASE-T Fast Ethernet standards require Category 5 or higher cabling.

The Ethernet connector has one LED that indicates Ethernet-link status. When this LED is lit, it indicates that there is an active connection on the Ethernet port. Activity between the computer and the network is indicated by the Ethernet transmit/receive activity LEDs on the front and rear of the computer (see “Controls and LEDs” on page 9).

IEEE 1394 (FireWire) connector (some models)

There is one 4-pin Institute of Electrical and Electronics Engineers (IEEE) 1394 (FireWire) connector on the front of the computer and one 6-pin IEEE 1394 (FireWire) connector on the rear of the computer. Use these connectors to connect IEEE 1394 (FireWire) devices. The following illustrations show the IEEE 1394 (FireWire) connectors.

4-pin IEEE 1394 (FireWire) connector (front)

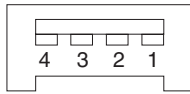

6-pin IEEE 1394 (FireWire) connector (rear)

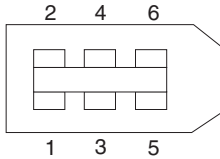

Keyboard connector

There is one keyboard connector on the rear of the computer. Use this connector to connect a PS/2 (non-USB) keyboard. The following illustration shows a keyboard connector.

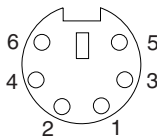

If you attach a keyboard to this connector, Universal Serial Bus (USB) ports and devices are disabled during the power-on self-test (POST).

Parallel connector

There is one parallel connector on the rear of the computer. Use this connector to connect a parallel device. The following illustration shows a parallel connector.

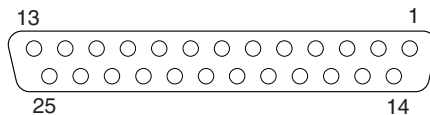

The parallel connector supports three standard IEEE 1284 modes of operation: standard parallel port (SPP), enhanced parallel port (EPP), and extended capability port (ECP). If you configure the parallel port to operate in bidirectional mode, it supports the ECP and EPP modes. When the parallel connector is configured as bidirectional, use an IEEE 1284-compliant cable that does not exceed 3 meters (9.8 ft). Use the **Devices and I/O Ports** options in the IBM Configuration/Setup Utility program to configure the parallel connector as bidirectional.

Serial connectors

There are two serial connectors on the rear of the computer. Use these connectors to connect serial devices. The following illustration shows a serial connector.

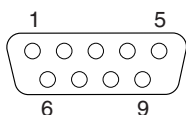

Ultra320 SCSI connector

The computer might have a mini-PCI SCSI controller. This single-channel controller supports an independent, Ultra320 SCSI channel that supports up to 15 SCSI devices. The SCSI connector for the channel is on the mini-PCI SCSI controller. The controller has the following features:

- Double-transition clocking to achieve up to 320 MBps (megabytes per second) data-transfer rates
- Domain name validation to negotiate compatible data-transfer speeds with each device
- Cyclic-redundancy checking (CRC) to improve data reliability
- An active terminator for SCSI bus termination

The following illustration shows a SCSI connector.

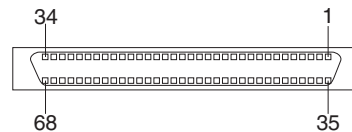

SCSI cabling requirements

You can install three internal SCSI devices using the SCSI signal cable that comes with some computer models. If you plan to attach external SCSI devices, you can order an optional SCSI adapter and external cable. To select and order the correct cables for use with external devices, contact your IBM marketing representative or authorized reseller. To receive an indication of SCSI hard-disk drive activity, you must also connect the SCSI adapter to the SCSI LED connector on the system board. See “System-board option connectors” on page 38 for the locations of the SCSI connectors.

Setting SCSI IDs

Each SCSI device that is connected to a SCSI controller must have a unique SCSI ID. This ID enables the SCSI controller to identify the device and ensure that different devices on the same SCSI channel do not attempt to transfer data simultaneously. SCSI devices that are connected to different SCSI channels can have duplicate SCSI IDs. See the information that comes with the device for instructions for setting its SCSI ID.

Universal Serial Bus connectors

There are eight USB 2.0 connectors, two on the front and six on the rear of the computer. Use the USB connectors to connect optional telephony and multimedia devices. USB 2.0 technology transfers data at up to 480 Mbps (megabits per second) with a maximum of 127 external devices and a maximum signal distance of 5 meters (16 ft) per segment (if the device that is attached to the computer is a USB 2.0 device). If multiple USB devices are attached to the computer, the USB hub must be USB 2.0; otherwise, all USB 2.0 devices will transfer data at 12 Mbps. Using Plug and Play technology, USB devices are configured automatically. The following illustration shows a USB connector.

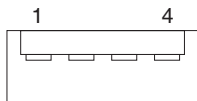

Use a 4-pin USB cable to connect an external device to a USB connector.

Video connector

The PCI Express x16 adapter (slot 2) provides the video connector. This connector is on the rear of the computer. Use the video connector to connect a monitor or other display device. The following illustrations show examples of different video connectors.

Analog video connector

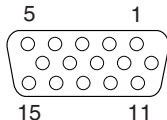

Digital (DVI-I) video connector

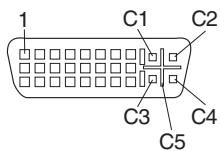

Dual monitor system-59 (DMS-59) video connector

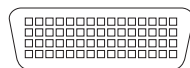

Some models come with a digital video interface (DVI) connector for connecting a digital monitor. If you have problems viewing information with a second monitor, see “Changing monitor settings” on page 16.

Models with the ATI FireGL V3100, ATI FireGL V7100, NVidia Quadro FX 1400, or 3DLabs Wildcat Realizm 800 video adapter come with a DVI-I to VGA style analog converter for each DVI-I connector.

Important: To get the best performance from the ATI FireGL V7100 or 3DLabs Wildcat Realizm 800 video adapter, you must connect the video adapter to the computer power supply. Otherwise, the video adapter will be operating with very limited power, resulting in a decrease in performance for some applications. Use the PCI Express x16 external power drop to connect the video adapter to the computer power supply. The following illustration shows the location of the video adapter power connector.

Note: The illustrations in this document may differ slightly from your hardware.

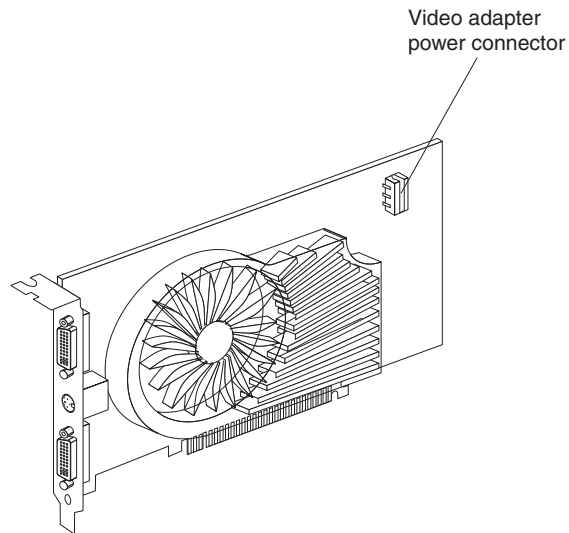

The following illustration shows the 3DLabs Wildcat Realizm 800 video adapter. When the 3DLabs video adapter is installed, it overlaps slot 1, PCI Express x1, that is next to it. Therefore, there is one less PCI slot available in which you can install an adapter.

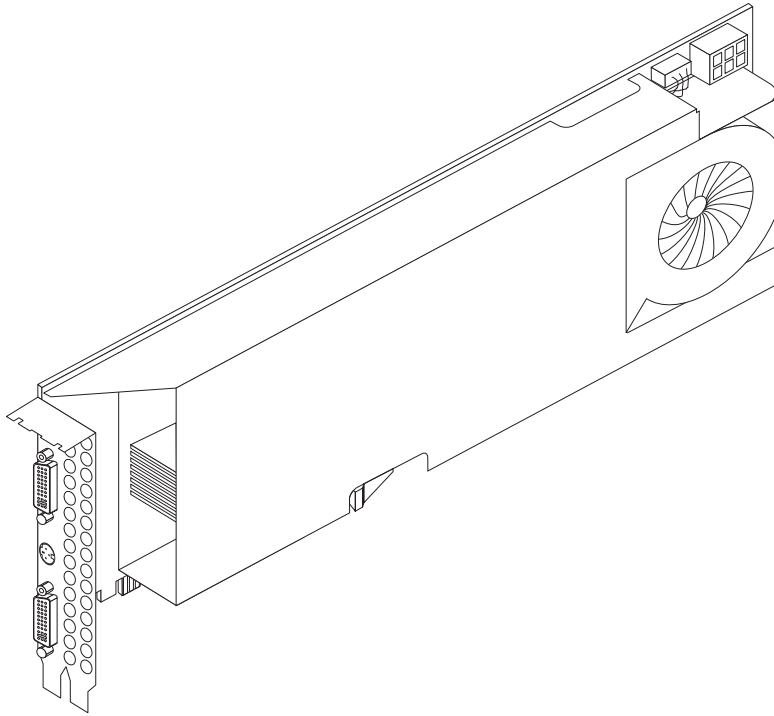

Models with the NVIDIA Quadro NVS 280 video adapter come with a dual monitor system-59 (DMS-59) to dual-analog monitor pigtail cable. If you want to set up two digital monitors, you must purchase a separate dual-digital monitor cable.

Appendix A. Getting help and technical assistance

If you need help, service, or technical assistance or just want more information about IBM products, you will find a wide variety of sources available from IBM to assist you. This appendix contains information about where to go for additional information about IBM and IBM products, what to do if you experience a problem with your @server™ or IntelliStation system or optional device, and whom to call for service, if it is necessary.

Before you call

Before you call, make sure that you have taken these steps to try to solve the problem yourself:

- Check all cables to make sure that they are connected.
- Check the power switches to make sure that the system and any optional devices are turned on.
- Use the troubleshooting information in your system documentation, and use the diagnostic tools that come with your system. Information about diagnostic tools is in the *Problem Determination and Service Guide* on the IBM Documentation CD, or from the IBM Support Website.
- Go to the IBM support Web site at <http://www.ibm.com/support/> to check for technical information, hints, tips, and new device drivers or to submit a request for information.

You can solve many problems without outside assistance by following the troubleshooting procedures that IBM provides in the online help or in the documentation that is provided with your IBM product. The documentation that comes with @server and IntelliStation systems also describes the diagnostic tests that you can perform. Most @server and IntelliStation systems, operating systems, and programs come with documentation that contains troubleshooting procedures and explanations of error messages and error codes. If you suspect a software problem, see the documentation for the operating system or program.

Using the documentation

Information about your IBM @server or IntelliStation system and preinstalled software, if any, or optional device is available in the documentation that comes with the product. That documentation can include printed documents, online documents, readme files, and help files. See the troubleshooting information in your system documentation for instructions for using the diagnostic programs. The troubleshooting information or the diagnostic programs might tell you that you need additional or updated device drivers or other software. IBM maintains pages on the World Wide Web where you can get the latest technical information and download device drivers and updates. To access these pages, go to <http://www.ibm.com/support/> and follow the instructions. Also, some documents are available through the IBM Publications Ordering System at <http://www.elink.ibm.com/public/applications/publications/cgibin/pbi.cgi>.

Getting help and information from the World Wide Web

On the World Wide Web, the IBM Web site has up-to-date information about IBM @server and IntelliStation systems, optional devices, services, and support. The address for IBM xSeries and BladeCenter information is <http://www.ibm.com/eserver/xseries/>. The address for IBM IntelliStation information is <http://www.ibm.com/intellistation/>.

You can find service information for IBM systems and optional devices at <http://www.ibm.com/support/>.

Software service and support

Through IBM Support Line, you can get telephone assistance, for a fee, with usage, configuration, and software problems with xSeries servers, BladeCenter products, IntelliStation workstations, and appliances. For information about which products are supported by Support Line in your country or region, see <http://www.ibm.com/services/sl/products/>.

For more information about Support Line and other IBM services, see <http://www.ibm.com/services/>, or see <http://www.ibm.com/planetwide/> for support telephone numbers. In the U.S. and Canada, call 1-800-IBM-SERV (1-800-426-7378).

Hardware service and support

You can receive hardware service through IBM Services or through your IBM reseller, if your reseller is authorized by IBM to provide warranty service. See <http://www.ibm.com/planetwide/> for support telephone numbers, or in the U.S. and Canada, call 1-800-IBM-SERV (1-800-426-7378).

In the U.S. and Canada, hardware service and support is available 24 hours a day, 7 days a week. In the U.K., these services are available Monday through Friday, from 9 a.m. to 6 p.m.

Appendix B. Notices

This publication was developed for products and services offered in the U.S.A.

IBM may not offer the products, services, or features discussed in this document in other countries. Consult your local IBM representative for information on the products and services currently available in your area. Any reference to an IBM product, program, or service is not intended to state or imply that only that IBM product, program, or service may be used. Any functionally equivalent product, program, or service that does not infringe any IBM intellectual property right may be used instead. However, it is the user's responsibility to evaluate and verify the operation of any non-IBM product, program, or service.

IBM may have patents or pending patent applications covering subject matter described in this document. The furnishing of this document does not give you any license to these patents. You can send license inquiries, in writing, to:

*IBM Director of Licensing
IBM Corporation
North Castle Drive
Armonk, NY 10504-1785
U.S.A.*

INTERNATIONAL BUSINESS MACHINES CORPORATION PROVIDES THIS PUBLICATION "AS IS" WITHOUT WARRANTY OF ANY KIND, EITHER EXPRESS OR IMPLIED, INCLUDING, BUT NOT LIMITED TO, THE IMPLIED WARRANTIES OF NON-INFRINGEMENT, MERCHANTABILITY OR FITNESS FOR A PARTICULAR PURPOSE. Some jurisdictions do not allow disclaimer of express or implied warranties in certain transactions, therefore, this statement may not apply to you.

This information could include technical inaccuracies or typographical errors. Changes are periodically made to the information herein; these changes will be incorporated in new editions of the publication. IBM may make improvements and/or changes in the product(s) and/or the program(s) described in this publication at any time without notice.

Any references in this publication to non-IBM Web sites are provided for convenience only and do not in any manner serve as an endorsement of those Web sites. The materials at those Web sites are not part of the materials for this IBM product, and use of those Web sites is at your own risk.

IBM may use or distribute any of the information you supply in any way it believes appropriate without incurring any obligation to you.

Edition notice

© Copyright International Business Machines Corporation, 2005. All rights reserved.

U.S. Government Users — Use, duplication, or disclosure restricted by GSA ADP Schedule Contract with IBM Corp.

Trademarks

The following terms are trademarks of International Business Machines Corporation in the United States, other countries, or both:

Active Memory	Predictive Failure Analysis
Active PCI	PS/2
Active PCI-X	ServeRAID
Alert on LAN	ServerGuide
BladeCenter	ServerProven
C2T Interconnect	TechConnect
Chipkill	ThinkPad
EtherJet	Trivoli
e-business logo	Trivoli Enterprise
@server	Update Connector
FlashCopy	Wake on LAN
IBM	XA-32
IBM (logo)	XA-64
IntelliStation	X-Architecture
NetBAY	XceL4
Netfinity	XpandOnDemand
NetView	xSeries
OS/2 WARP	

Intel, MMX, and Pentium are trademarks of Intel Corporation in the United States, other countries, or both.

Microsoft, Windows, and Windows NT are trademarks of Microsoft Corporation in the United States, other countries, or both.

UNIX is a registered trademark of The Open Group in the United States and other countries.

Java and all Java-based trademarks and logos are trademarks of Sun Microsystems, Inc. in the United States, other countries, or both.

Adaptec and HostRAID are trademarks of Adaptec, Inc., in the United States, other countries, or both.

Linux is a trademark of Linus Torvalds in the United States, other countries, or both.

Red Hat, the Red Hat "Shadow Man" logo, and all Red Hat-based trademarks and logos are trademarks or registered trademarks of Red Hat, Inc., in the United States and other countries.

Other company, product, or service names may be trademarks or service marks of others.

Important notes

Processor speeds indicate the internal clock speed of the microprocessor; other factors also affect application performance.

CD-ROM drive speeds list the variable read rate. Actual speeds vary and are often less than the maximum possible.

When referring to processor storage, real and virtual storage, or channel volume, KB stands for approximately 1000 bytes, MB stands for approximately 1 000 000 bytes, and GB stands for approximately 1 000 000 000 bytes.

When referring to hard disk drive capacity or communications volume, MB stands for 1 000 000 bytes, and GB stands for 1 000 000 000 bytes. Total user-accessible capacity may vary depending on operating environments.

Maximum internal hard disk drive capacities assume the replacement of any standard hard disk drives and population of all hard disk drive bays with the largest currently supported drives available from IBM.

Maximum memory may require replacement of the standard memory with an optional memory module.

IBM makes no representation or warranties regarding non-IBM products and services that are ServerProven[®], including but not limited to the implied warranties of merchantability and fitness for a particular purpose. These products are offered and warranted solely by third parties.

IBM makes no representations or warranties with respect to non-IBM products. Support (if any) for the non-IBM products is provided by the third party, not IBM.

Some software may differ from its retail version (if available), and may not include user manuals or all program functionality.

Product recycling and disposal

This unit must be recycled or discarded according to applicable local and national regulations. IBM encourages owners of information technology (IT) equipment to responsibly recycle their equipment when it is no longer needed. IBM offers a variety of product return programs and services in several countries to assist equipment owners in recycling their IT products. Information on IBM product recycling offerings can be found on IBM's Internet site at <http://www.ibm.com/ibm/environment/products/prp.shtml>.

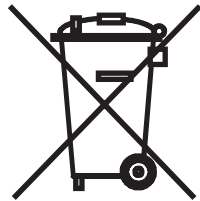

Notice: This mark applies only to countries within the European Union (EU) and Norway.

This appliance is labeled in accordance with European Directive 2002/96/EC concerning waste electrical and electronic equipment (WEEE). The Directive determines the framework for the return and recycling of used appliances as

applicable throughout the European Union. This label is applied to various products to indicate that the product is not to be thrown away, but rather reclaimed upon end of life per this Directive.

注意: このマークは EU 諸国およびノルウェーにおいてのみ適用されます。

この機器には、EU 諸国に対する廃電気電子機器指令 2002/96/EC(WEEE) のラベルが貼られています。この指令は、EU 諸国に適用する使用済み機器の回収とリサイクルの骨子を定めています。このラベルは、使用済みになった時に指令に従って適正な処理をする必要があることを知らせるために種々の製品に貼られています。

Remarque : Cette marque s'applique uniquement aux pays de l'Union Européenne et à la Norvège.

L'étiquette du système respecte la Directive européenne 2002/96/EC en matière de Déchets des Equipements Electriques et Electroniques (DEEE), qui détermine les dispositions de retour et de recyclage applicables aux systèmes utilisés à travers l'Union européenne. Conformément à la directive, ladite étiquette précise que le produit sur lequel elle est apposée ne doit pas être jeté mais être récupéré en fin de vie.

Battery return program

This product may contain a sealed lead acid, nickel cadmium, nickel metal hydride, lithium, or lithium ion battery. Consult your user manual or service manual for specific battery information. The battery must be recycled or disposed of properly. Recycling facilities may not be available in your area. For information on disposal of batteries outside the United States, go to <http://www.ibm.com/ibm/environment/products/batteryrecycle.shtml> or contact your local waste disposal facility.

In the United States, IBM has established a return process for reuse, recycling, or proper disposal of used IBM sealed lead acid, nickel cadmium, nickel metal hydride, and battery packs from IBM equipment. For information on proper disposal of these batteries, contact IBM at 1-800-426-4333. Have the IBM part number listed on the battery available prior to your call.

In the Netherlands, the following applies.



For Taiwan: Please recycle batteries.



Electronic emission notices

IBM IntelliStation M Pro Type 6218

Federal Communications Commission (FCC) statement

Note: This equipment has been tested and found to comply with the limits for a Class B digital device, pursuant to Part 15 of the FCC Rules. These limits are designed to provide reasonable protection against harmful interference in a residential installation. This equipment generates, uses, and can radiate radio frequency energy and, if not installed and used in accordance with the instructions, may cause harmful interference to radio communications. However, there is no guarantee that interference will not occur in a particular installation. If this equipment does cause harmful interference to radio or television reception, which can be determined by turning the equipment off and on, the user is encouraged to try to correct the interference by one or more of the following measures:

- Reorient or relocate the receiving antenna.
- Increase the separation between the equipment and receiver.
- Connect the equipment into an outlet on a circuit different from that to which the receiver is connected.
- Consult an IBM authorized dealer or service representative for help.

Properly shielded and grounded cables and connectors must be used in order to meet FCC emission limits. Proper cables and connectors are available from IBM authorized dealers. IBM is not responsible for any radio or television interference caused by using other than recommended cables and connectors or by unauthorized changes or modifications to this equipment. Unauthorized changes or modifications could void the user's authority to operate the equipment.

This device complies with Part 15 of the FCC Rules. Operation is subject to the following two conditions: (1) this device may not cause harmful interference, and (2) this device must accept any interference received, including interference that may cause undesired operation.

Responsible party:

International Business Machines Corporation
New Orchard Road
Armonk, NY 10504
Telephone: 1-919-543-2193

 Tested To Comply
With FCC Standards
FOR HOME OR OFFICE USE

Industry Canada Class B emission compliance statement

This Class B digital apparatus complies with Canadian ICES-003.

Avis de conformité à la réglementation d'Industrie Canada

Cet appareil numérique de la classe B est conforme à la norme NMB-003 du Canada.

European Union EMC Directive conformance statement

This product is in conformity with the protection requirements of EU Council Directive 89/336/EEC on the approximation of the laws of the Member States

relating to electromagnetic compatibility. IBM cannot accept responsibility for any failure to satisfy the protection requirements resulting from a nonrecommended modification of the product, including the fitting of non-IBM option cards. This product has been tested and found to comply with the limits for Class B Information Technology Equipment according to CISPR 22/European Standard EN 55022. The limits for Class B equipment were derived for typical residential environments to provide reasonable protection against interference with licensed communication devices.

Japanese Voluntary Control Council for Interference (VCCI) statement

この装置は、情報処理装置等電波障害自主規制協議会（VCCI）の基準に基づくクラスB情報技術装置です。この装置は、家庭環境で使用することを目的としていますが、この装置がラジオやテレビジョン受信機に近接して使用されると、受信障害を引き起こすことがあります。
取扱説明書に従って正しい取り扱いをして下さい。

Power cords

For your safety, IBM provides a power cord with a grounded attachment plug to use with this IBM product. To avoid electrical shock, always use the power cord and plug with a properly grounded outlet.

IBM power cords used in the United States and Canada are listed by Underwriter's Laboratories (UL) and certified by the Canadian Standards Association (CSA).

For units intended to be operated at 115 volts: Use a UL-listed and CSA-certified cord set consisting of a minimum 18 AWG, Type SVT or SJT, three-conductor cord, a maximum of 15 feet in length and a parallel blade, grounding-type attachment plug rated 15 amperes, 125 volts.

For units intended to be operated at 230 volts (U.S. use): Use a UL-listed and CSA-certified cord set consisting of a minimum 18 AWG, Type SVT or SJT, three-conductor cord, a maximum of 15 feet in length and a tandem blade, grounding-type attachment plug rated 15 amperes, 250 volts.

For units intended to be operated at 230 volts (outside the U.S.): Use a cord set with a grounding-type attachment plug. The cord set should have the appropriate safety approvals for the country in which the equipment will be installed.

IBM power cords for a specific country or region are usually available only in that country or region.

IBM power cord part number	Used in these countries and regions
02K0546	China
13F9940	Australia, Fiji, Kiribati, Nauru, New Zealand, Papua New Guinea

IBM power cord part number	Used in these countries and regions
13F9979	Afghanistan, Albania, Algeria, Andorra, Angola, Armenia, Austria, Azerbaijan, Belarus, Belgium, Benin, Bosnia and Herzegovina, Bulgaria, Burkina Faso, Burundi, Cambodia, Cameroon, Cape Verde, Central African Republic, Chad, Comoros, Congo (Democratic Republic of), Congo (Republic of), Cote D'Ivoire (Ivory Coast), Croatia (Republic of), Czech Republic, Dahomey, Djibouti, Egypt, Equatorial Guinea, Eritrea, Estonia, Ethiopia, Finland, France, French Guyana, French Polynesia, Germany, Greece, Guadeloupe, Guinea, Guinea Bissau, Hungary, Iceland, Indonesia, Iran, Kazakhstan, Kyrgyzstan, Laos (People's Democratic Republic of), Latvia, Lebanon, Lithuania, Luxembourg, Macedonia (former Yugoslav Republic of), Madagascar, Mali, Martinique, Mauritania, Mauritius, Mayotte, Moldova (Republic of), Monaco, Mongolia, Morocco, Mozambique, Netherlands, New Caledonia, Niger, Norway, Poland, Portugal, Reunion, Romania, Russian Federation, Rwanda, Sao Tome and Principe, Saudi Arabia, Senegal, Serbia, Slovakia, Slovenia (Republic of), Somalia, Spain, Suriname, Sweden, Syrian Arab Republic, Tajikistan, Tahiti, Togo, Tunisia, Turkey, Turkmenistan, Ukraine, Upper Volta, Uzbekistan, Vanuatu, Vietnam, Wallis and Futuna, Yugoslavia (Federal Republic of), Zaire
13F9997	Denmark
14F0015	Bangladesh, Lesotho, Maceo, Maldives, Namibia, Nepal, Pakistan, Samoa, South Africa, Sri Lanka, Swaziland, Uganda
14F0033	Abu Dhabi, Bahrain, Botswana, Brunei Darussalam, Channel Islands, China (Hong Kong S.A.R.), Cyprus, Dominica, Gambia, Ghana, Grenada, Iraq, Ireland, Jordan, Kenya, Kuwait, Liberia, Malawi, Malaysia, Malta, Myanmar (Burma), Nigeria, Oman, Polynesia, Qatar, Saint Kitts and Nevis, Saint Lucia, Saint Vincent and the Grenadines, Seychelles, Sierra Leone, Singapore, Sudan, Tanzania (United Republic of), Trinidad and Tobago, United Arab Emirates (Dubai), United Kingdom, Yemen, Zambia, Zimbabwe
14F0051	Liechtenstein, Switzerland
14F0069	Chile, Italy, Libyan Arab Jamahiriya
14F0087	Israel
1838574	Antigua and Barbuda, Aruba, Bahamas, Barbados, Belize, Bermuda, Bolivia, Brazil, Caicos Islands, Canada, Cayman Islands, Costa Rica, Colombia, Cuba, Dominican Republic, Ecuador, El Salvador, Guam, Guatemala, Haiti, Honduras, Jamaica, Japan, Mexico, Micronesia (Federal States of), Netherlands Antilles, Nicaragua, Panama, Peru, Philippines, Taiwan, United States of America, Venezuela
24P6858	Korea (Democratic People's Republic of), Korea (Republic of)
34G0232	Japan
36L8880	Argentina, Paraguay, Uruguay
49P2078	India
49P2110	Brazil

IBM power cord part number	Used in these countries and regions
6952300	Antigua and Barbuda, Aruba, Bahamas, Barbados, Belize, Bermuda, Bolivia, Caicos Islands, Canada, Cayman Islands, Colombia, Costa Rica, Cuba, Dominican Republic, Ecuador, El Salvador, Guam, Guatemala, Haiti, Honduras, Jamaica, Mexico, Micronesia (Federal States of), Netherlands Antilles, Nicaragua, Panama, Peru, Philippines, Saudi Arabia, Thailand, Taiwan, United States of America, Venezuela

Index

A

- acoustical noise emissions 4
 - adapter
 - considerations 45
 - full length 45
 - IEEE 1394 (FireWire) 45
 - installing 45
 - PCI bus 45
 - SCSI 48
 - advanced setup 24
 - audio
 - connectors 16, 68
 - controller 16
 - features 16
- ## B
- battery
 - connector 38
 - bays
 - 2 and 4 50
 - filler panel 51, 54, 56, 58
 - bezel, removing 42
 - bi-directional parallel port configuration 70
 - Boot Menu
 - using 25
 - Broadcom NetXtreme Gigabit Ethernet Boot Agent
 - enabling 26
 - general 21

C

- cable
 - connectors 40
- cables
 - internal drives 60
 - power 60
 - power and signal 60
 - signal 60
 - USB 72
- cabling
 - Ethernet 69
 - SCSI adapter 48
 - SCSI requirements 71
 - system-board external connectors 40
- CD-ROM drive
 - eject button 9
 - installing 49
- channels, SCSI 71
- Class B electronic emission notice 81
- components
 - of the computer 37
 - system board 38
- computer
 - configuring 21
 - model number location 1
 - serial number location 1

- computer (*continued*)
 - shutting down 19
 - turning on 10
- configuration programs
 - Broadcom NetXtreme Gigabit Ethernet Boot Agent 21
 - Configuration/Setup Utility program 21
 - general 21
 - SCSISelect Utility program 22
- configuring
 - the computer 21
 - the Ethernet controller 32
- connecting
 - external options 67
- connector
 - audio 68
 - DVI monitor pin-assignments 73
 - serial 70
 - serial port pin-assignments 70
 - universal serial bus (USB) 72
 - video 72
- connectors
 - adapter 38
 - battery 38
 - external port 40
 - IEEE 1394 (FireWire) 69
 - input/output 68
 - memory 38
 - microprocessor 38
 - port 40
 - system board 38
 - Ultra320 SCSI 71
- controller
 - Ethernet 32
 - SCSI 48
- controls and indicators 9
- cooling 35
- cover
 - removing 41
 - replacing 67
- creating
 - an emergency recovery diskette in Windows 13

D

- data protection
 - SMART hard disk drive 17
 - virus protection 17
- data rate, Ethernet controller 32
- diagnostics
 - downloading 14
- DIMM connector
 - installing memory 62
 - locations 62
- DIMM retaining clips 63
- diskette
 - drive activity LED 9

diskette (*continued*)
 eject button 9
 recovery repair
 for Windows 13

diskette drive
 installing 49, 50

drive
 bay filler panel 51, 54, 56, 58
 installation 50

drives
 installing 49

E

electrical input 4

electronic emission Class B notice 81

enabling
 Broadcom NetXtreme Gigabit Ethernet Boot
 Agent 26

environment 4

Ethernet
 cabling 69
 connector pin-number assignments 69
 high performance modes 32
 integrated on system board 32
 modes 32
 pin-number assignment 69
 port 69
 teaming 32

Ethernet controller 5
 configuring 32

Ethernet controller configuration 21

Ethernet controller, configuring 32

external options
 connecting 67

F

FCC Class B notice 81

features and specifications 4

filler panel 51, 54, 56, 58

G

guidelines
 for options installation 35

H

handling static-sensitive devices 36

hard disk drive
 installing 49

heat output 4

I

IBM Configuration/Setup Utility program
 menu choices 22
 starting 22
 using 22

IBM Director Agent 18

IDs, setting SCSI 71

IEEE 1394 (FireWire) adapter 45

IEEE 1394 (FireWire) connectors 69

IEEE 1394 (Firewire) enable/disable jumper
 location 39

information, related publications 1

installation order, memory modules 62

installing
 adapters 45
 drive in bays 2 or 4 50
 internal drives 49
 memory modules 62
 options 35
 other operating systems 12
 security rope clip 64

internal
 connectors 39
 drives, installing 49

L

LEDs
 activity 9, 10

Linux
 registering your computer 13

local area network (LAN) 5

M

managing your computer 18

memory
 installing 62
 modules 62
 system 5

memory module
 order of installation 62
 specifications 5
 supported 62

memory module, specifications 4

microprocessor
 cache 24

microprocessor specifications 4

modes, Ethernet 32

monitor
 settings 16

mouse
 connector pin-assignments 69
 port 69

N

notes, important 78

notices
 book 3
 electronic emission 81
 FCC, Class B 81

O

- operating your computer 9
- options
 - installation 35
- options installation
 - guidelines 35
- order of installation, memory modules 62

P

- parallel port
 - connector 70
 - connector pin-assignments 70
- password
 - administrator 17
 - forgotten power-on 25
 - setting 23
 - user 17
- passwords
 - using 24
- PCI configuration 24
- PCI expansion slots 4
- pin-assignments
 - video 73
- pin-number assignments, Ethernet 69
- port
 - connectors 40
 - Ethernet 69
- port, Ethernet 69
- ports
 - input/output 68
 - universal serial bus (USB) 72
- power
 - control button 10
- power cords 82
- power supply specifications 4
- power-on LED 9, 10
- processor control 24

R

- RAS features 8
- recovery repair diskette
 - creating
 - in Windows 13
- Red Hat
 - registering your computer 13
- registering
 - your computer in Windows 13
- registering your computer
 - in Red Hat Linux 13
- related documentation 1
- reliability, system 35
- Remote Deployment Manager 19
- removable media drives, installing 49
- removing
 - bezel 42
 - side cover 41
- replacing
 - the cover 67

- retaining clips, DIMM 63
- rope clip
 - installing for security 64
- running
 - the operating system setup program 12

S

- Safety information vii
- SCSI connector
 - description 71
- SCSI controller cabling 48
- SCSISelect Utility program
 - menu choices 32
 - starting 32
 - using 32
- security
 - anti-intrusion 17
 - chassis-intrusion detector 17
 - component protection 17
 - data protection 17
 - features 17
 - locking the keyboard 17
 - passwords 17
 - rope clip 64
 - SMART hard disk drive 17
 - virus protection 17
- serial
 - connector pin-assignments 70
- setup
 - advanced 24
- side cover, removing 41
- size 4
- small computer systems interface (SCSI)
 - cabling requirements 71
 - setting IDs 71
- software 5
 - available on the Web 7
 - CDs 6
 - network management 18
 - other 7
 - preinstalled 6
 - system management 18
- starting
 - SCSISelect Utility program 32
- starting the computer 11
- static-sensitive devices, handling 36
- system
 - major components 37
- system board
 - connectors
 - external port 40
 - SCSI 71
 - internal connectors 39
 - option connectors 38
- system management
 - capabilities 5
 - IBM Director Agent 18
 - Remote Deployment Manager 19
 - Wake on LAN 18, 19
- system offerings 5

- system programs
 - updating 18
- system reliability 35

T

- tape drive, installing 49
- trademarks 78
- turn on computer 10
- turning off
 - the computer 19

U

- Ultra320 SCSI connector 71
- United States electronic emission Class B notice 81
- United States FCC Class B notice 81
- universal serial bus (USB)
 - cables 72
 - connectors 72
 - ports 72
- updating
 - system programs 18
- using
 - Boot Menu program 25
 - Configuration/Setup Utility program 21
 - IBM Configuration/Setup Utility program 22
 - passwords 23, 24
 - SCSISelect Utility program 32

V

- video
 - connector 72
 - device drivers 15
 - DVI connector 73
 - DVI connector pin-assignments 73
 - features 15
 - monitor settings 16
- video controller 4
 - specifications 4

W

- Wake on LAN 18, 19
- weight 4
- Windows
 - registering your computer 13



Part Number: 31R1997

Printed in USA

(1P) P/N: 31R1997

